

SERIES PW9020A ALUMINUM, IMPACT RESISTANT FIXED WINDOW

1) THIS PRODUCT HAS BEEN DESIGNED & TESTED TO COMPLY WITH REQUIREMENTS OF THE 2018 INTERNATIONAL BUILDING CODE AND 2018 INTERNATIONAL RESIDENTIAL CODE.

2) SHUTTERS ARE NOT REQUIRED WHEN USED IN WIND-BORNE DEBRIS REGIONS.

3) MASONRY ANCHORS MAY BE USED INTO WOOD AS PER TABLE 2. ALL WOOD BUCKS LESS THAN 1-1/2" THICK ARE TO BE CONSIDERED 1X INSTALLATIONS. 1X WOOD BUCKS ARE OPTIONAL IF UNIT IS INSTALLED DIRECTLY TO SUBSTRATE. WOOD BUCKS DEPICTED AS 2X ARE 1-1/2" THICK OR GREATER. 1X AND 2X BUCKS (WHEN USED) SHALL BE DESIGNED TO PROPERLY TRANSFER LOADS TO THE STRUCTURE. WOOD BUCK DESIGN AND INSTALLATION IS THE RESPONSIBILITY OF THE ENGINEER OR ARCHITECT OF RECORD.

4) ANCHOR EMBEDMENT TO BASE MATERIAL SHALL BE BEYOND WALL DRESSING OR STUCCO. USE ANCHORS OF SUFFICIENT LENGTH. ANCHORS AND FRAME CORNERS SHOULD BE SEALED. OVERALL SEALING/FLASHING STRATEGY FOR WATER RESISTANCE OF INSTALLATION SHALL BE DONE BY OTHERS AND IS BEYOND THE SCOPE OF THESE INSTRUCTIONS.

5) SHIMS ARE REQUIRED AT EACH ANCHOR LOCATION WHERE THE PRODUCT IS NOT FLUSH TO THE SUBSTRATE. USE SHIMS CAPABLE OF TRANSFERRING APPLIED LOADS. WOOD BUCKS, BY OTHERS, MUST BE SUFFICIENTLY ANCHORED TO RESIST LOADS IMPOSED ON THEM BY THE WINDOW.

6) THE ANCHORAGE METHODS SHOWN HAVE BEEN DESIGNED TO RESIST THE WIND LOADS CORRESPONDING TO THE REQUIRED DESIGN PRESSURE. THE 33-1/3% STRESS INCREASE HAS NOT BEEN USED IN THE DESIGN OF THIS PRODUCT. THE 1.6 LOAD DURATION FACTOR WAS USED FOR THE EVALUATION OF ANCHORS INTO WOOD. ANCHORS THAT COME INTO CONTACT WITH OTHER DISSIMILAR MATERIALS SHALL MEET THE REQUIREMENTS OF THE BUILDING CODE FOR CORROSION RESISTANCE.

TABLE 1:

Buck Width	Buck Height	Configuration	Glass Type (see Sheet 6)	Rating / Design Pressure	Certification #
60"	120"	Single Lite, O	A	AW +/-100	167-504, 167-754
60"	120"	Single Lite, O	B	AW +/-90	167-505, 167-755
60"	120"	Double Lite, O/O	A & B	AW +100/-120	167-506, 167-756
96"	72"	Single Lite, O	A & B	AW +/-110	167-507, 167-757
144"	72"	Triple Lite, OOO	A & B	AW +/-85	167-514, 167-764

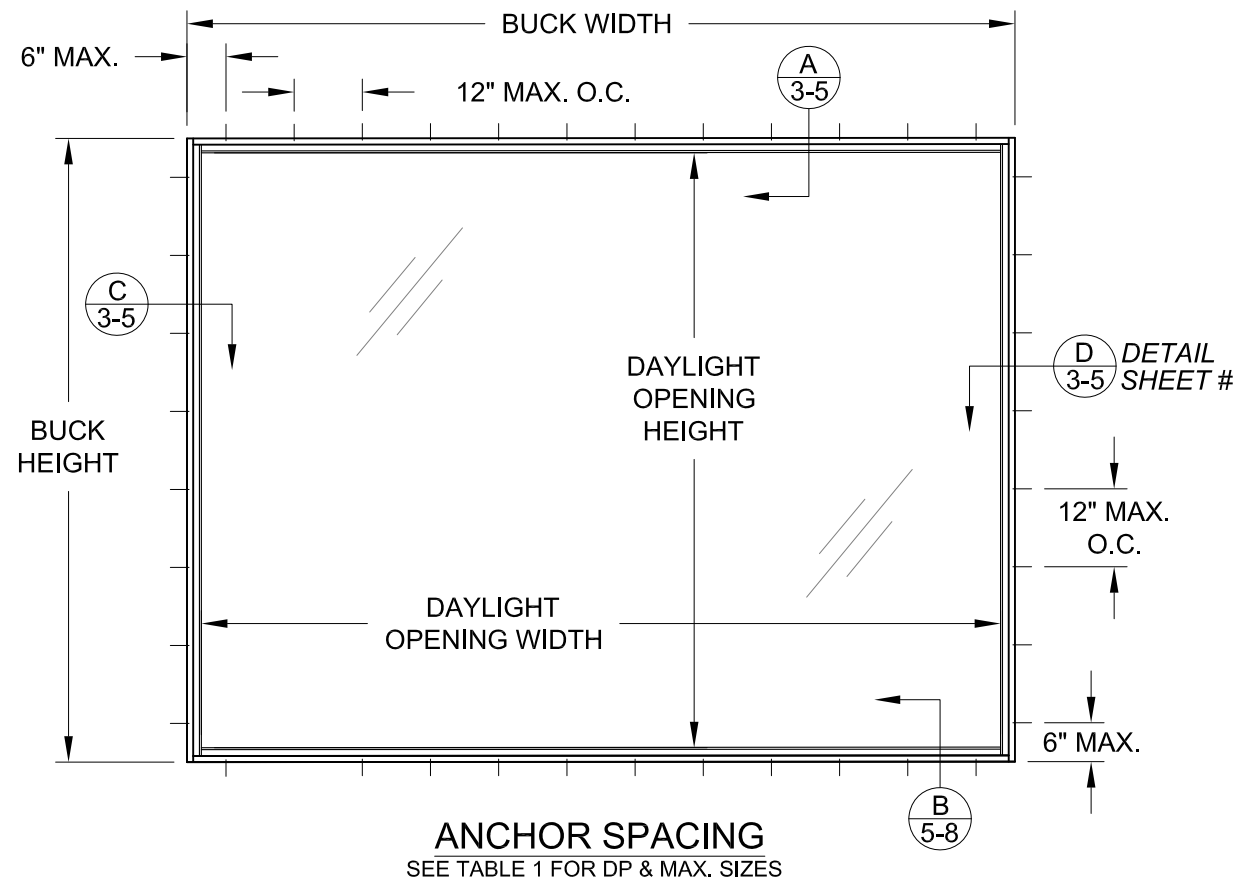

ANCHOR SPACING
SEE TABLE 1 FOR DP & MAX. SIZES

DLO = BUCK WIDTH OR HEIGHT - 2.230" - 2.230"
USING STANDARD RAILS.
IF USING OPTIONAL TALL RAILS, SEE SHEET 7
FOR FRAME MEMBER HEIGHT DEDUCTIONS.

ALL ARCHITECTURAL WINDOW SHAPES WITH STD. RAILS QUALIFIED, COMMON EXAMPLES SHOWN BELOW. INSCRIBE THE SHAPE IN A BLOCK (SEE EXAMPLES BELOW), AND OBTAIN DESIGN PRESSURES FOR THAT BLOCK SIZE FROM DESIGN PRESSURE TABLES.

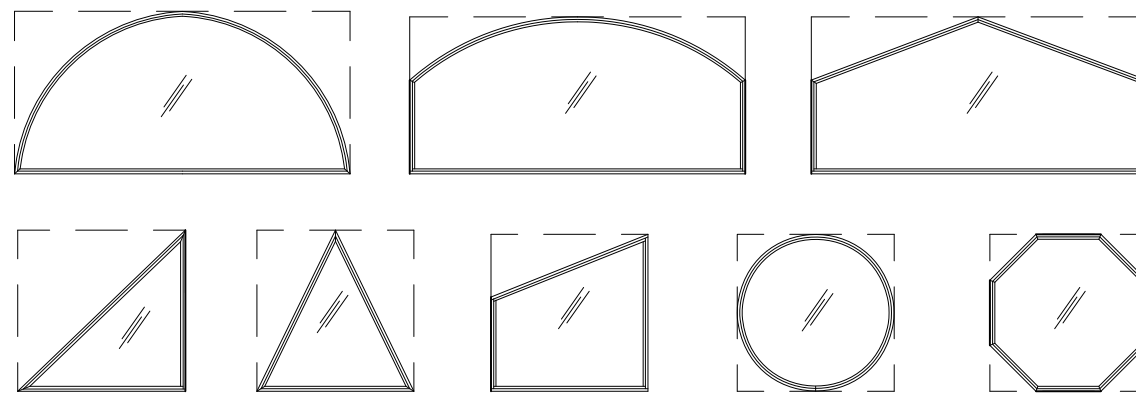

DESIGN PRESSURE RATING
SEE TABLE 1

IMPACT RATING
RATED FOR LARGE & SMALL
MISSILE IMPACT RESISTANCE
MISSILE LEVEL D, WINDZONE 4

PREPARED BY A. LYNN MILLER 1070 TECHNOLOGY DRIVE N. VENICE, FL 34275 (941) 480-1600 WINDOOR INCORPORATED WINDOOR INCORPORATED 104 TRIPLE DIAMOND BLVD N. VENICE, FL 34275 (833) 554-5432	06/15/22 Date	JENS ROSOWSKI By	9020TDI-LM-1 DWG No.	1 OF 7 Sheet
	ALUMINUM FIXED WINDOW (LM) Title		ELEVATION & GENERAL NOTES Desc.	

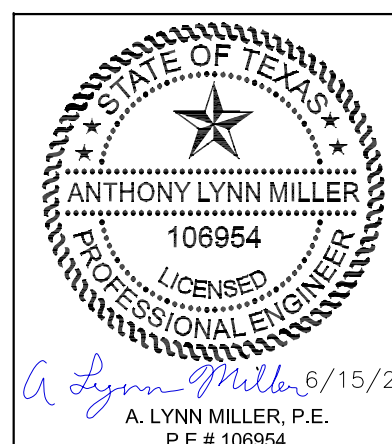

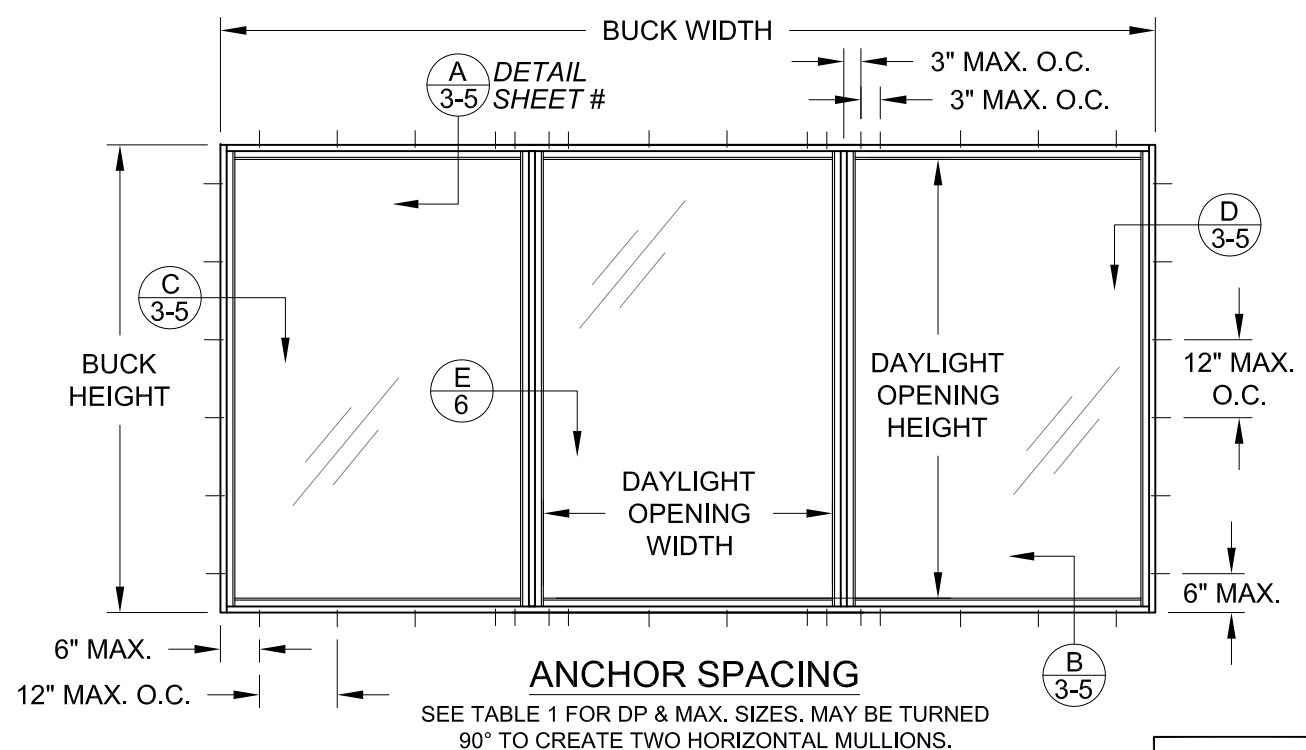

SEE TABLE 1 FOR DP & MAX. SIZES. MAY BE TURNED 90° TO CREATE TWO HORIZONTAL MULLIONS.

SEE SHEET 9 FOR MULLION & FRAME MEMBER DEDUCTIONS REQUIRED TO CALCULATE DLO.

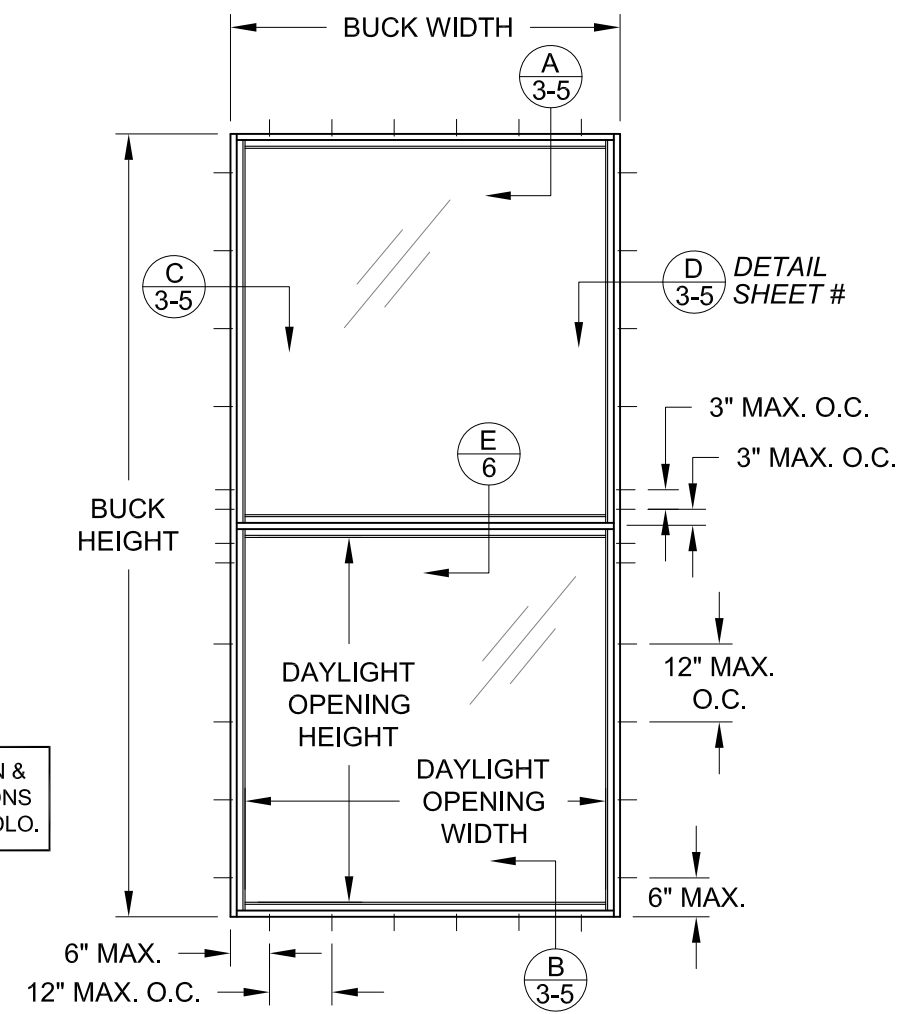

SEE TABLE 1 FOR DP & MAX. SIZES. MAY BE TURNED 90° TO CREATE A SINGLE, VERTICAL MULLION.

TABLE 2:

Anchor Type	Substrate	Min. Edge Distance	Min. O.C. Distance	Min. Embedment or Metal Thickness
#12 Steel SMS (Gr. 5) or 410 SS SMS	Southern Pine (SG = 0.55)	9/16"	1"	1-3/8"
	6063-T5 Aluminum	3/8"	1"	0.125"
	A36 Steel	3/8"	1"	0.045" (18 Ga)
	Steel Stud, Gr. 33	3/8"	1"	0.045" (18 Ga)
1/4" DeWalt UltraCon+	Concrete (min. 3.0 ksi)	1-3/4"	4"	1-3/8"
	Grout-filled CMU (ASTM C90)	1-3/4"	4"	1-3/4"
	Hollow CMU (ASTM C90)	2"	3"	1-1/4"
	Southern Pine (SG = 0.55)	1"	1"	1-3/8"
1/4" 410 SS Elco CreteFlex	Concrete (min. 3.35 ksi)	1-1/4"	6"	1-3/4"
	Hollow or Grout-filled CMU (ASTM C90)	1-3/4"	6"	1-1/4"
	Southern Pine (SG = 0.55)	1"	1"	1-3/8"

- 1) ALL ANCHOR HEAD TYPES ARE APPLICABLE.
- 2) ANCHORS MUST BE OF SUFFICIENT LENGTH SO THAT A MINIMUM OF 3 THREADS EXTEND BEYOND METAL SUBSTRATE.

PREPARED BY A. LYNN MILLER 1070 TECHNOLOGY DRIVE N. VENICE, FL 34275 (941) 480-1600	WINDOOR INCORPORATED WINDOOR INCORPORATED 104 TRIPLE DIAMOND BLVD N. VENICE, FL 34275 (833) 554-5432	Date	06/15/22
		By	JENS ROSOWSKI
ALUMINUM FIXED WINDOW (LM)		DWG No.	9020TDI-LM-1
DESIGN PRESSURE TABLES		Sheet	2 OF 7
PW9020A		Series	

COPYRIGHT © 2022 WINDOOR, INC., LIMITED LICENSE TO MAKE COPIES FOR PERMITTING.

ANTHONY LYNN MILLER
106954
LICENSED PROFESSIONAL ENGINEER

A Lynn Miller 6/15/22
A. LYNN MILLER, P.E.
P.E.# 106954

A FLANGE FRAME @ HEAD
INSTALLED DIRECTLY TO SUBSTRATE

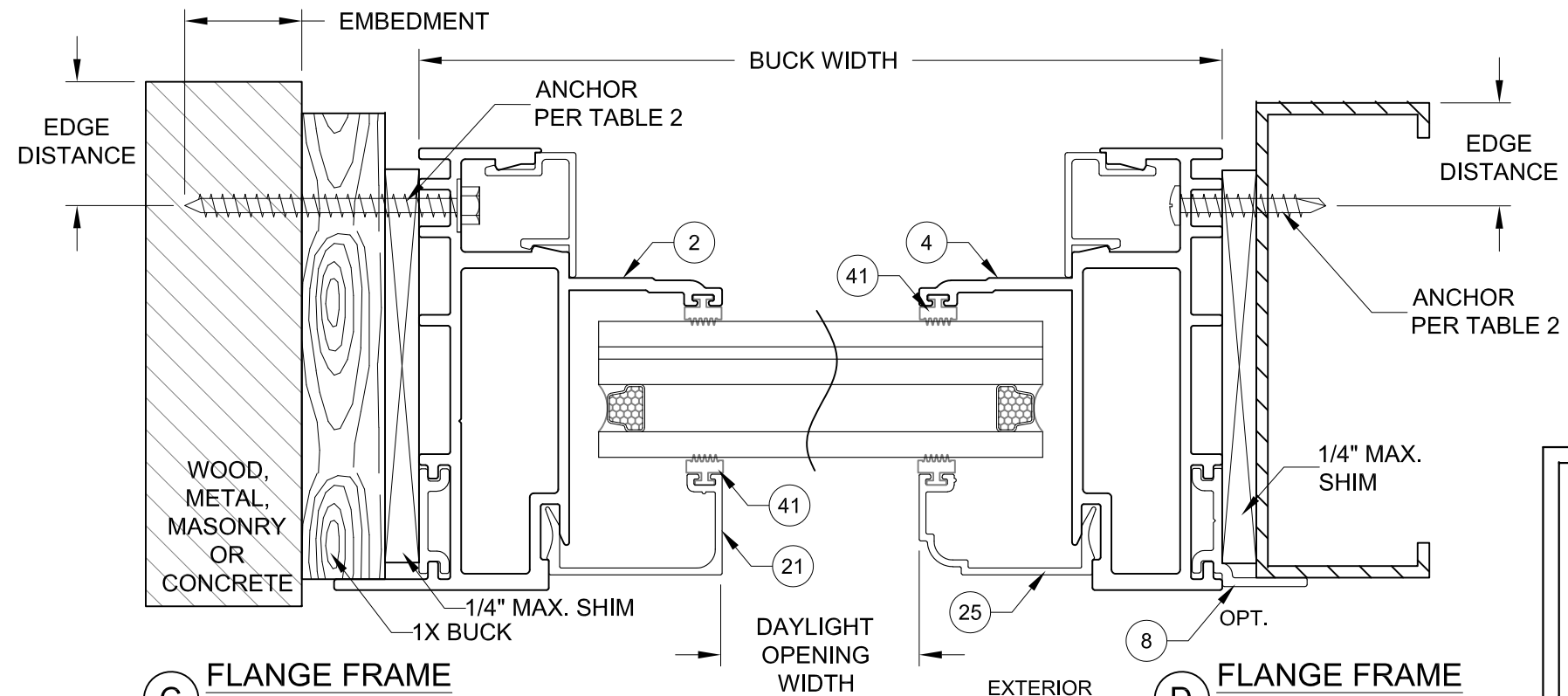
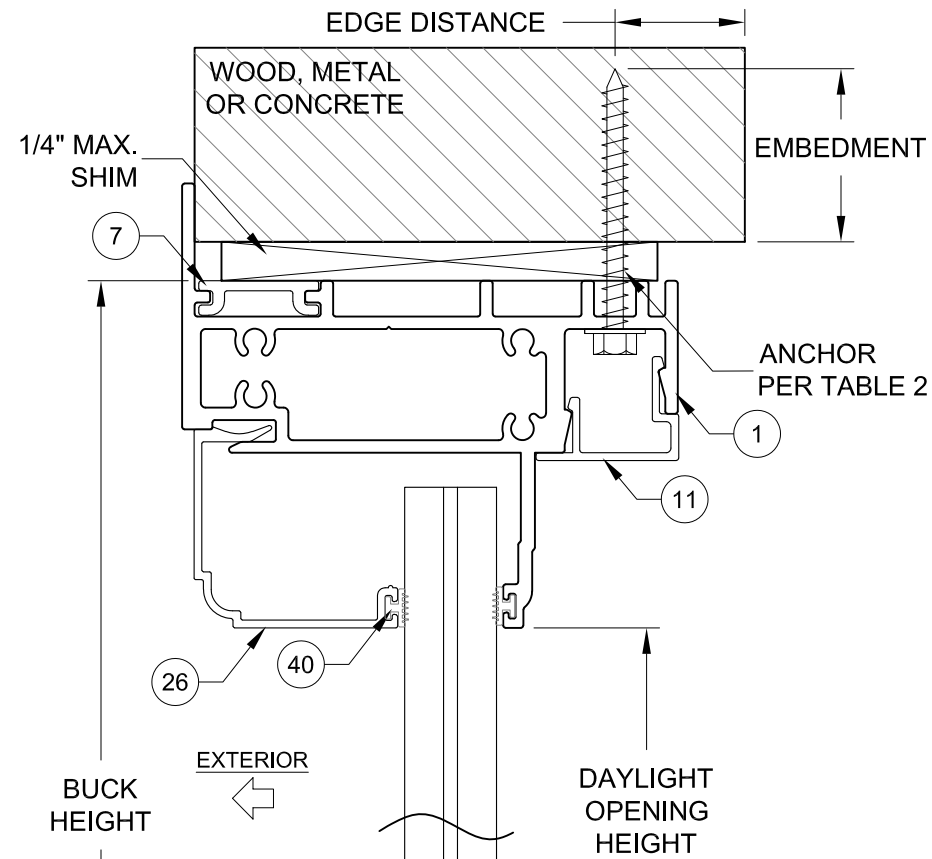

C FLANGE FRAME @ LEFT JAMB
USING 1X BUCK

D FLANGE FRAME @ RIGHT JAMB
METAL SUBSTRATE (SHOWN WITH OPT. FLANGE ADAPTER)

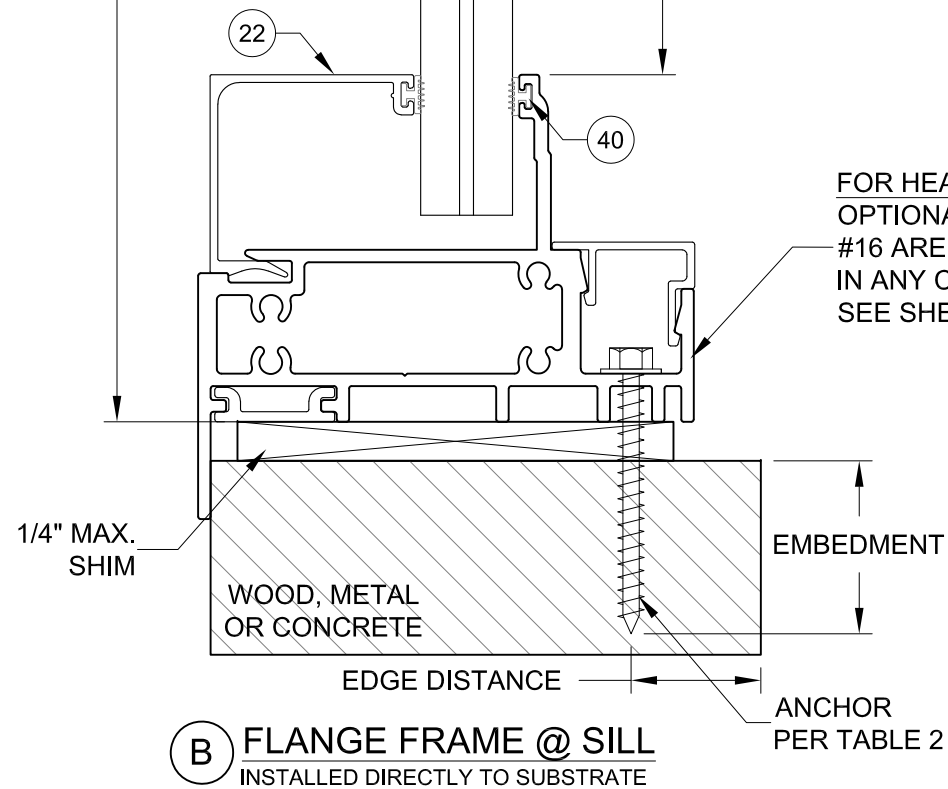

B FLANGE FRAME @ SILL
INSTALLED DIRECTLY TO SUBSTRATE

FOR HEAD AND SILL:
OPTIONAL RAILS #14, #15 &
#16 ARE ALSO APPROVED
IN ANY COMBINATIONS.
SEE SHEET 7.

INSTALLATION NOTES:

- 1) SEE SHEET 1 FOR SPACING REQUIREMENTS.
- 2) USE ONLY SUBSTRATE APPROPRIATE ANCHORS LISTED IN TABLE 2. FOLLOW EMBEDMENT AND EDGE DISTANCE DIMENSIONS FROM TABLE 1 AND O.C. DIMENSION FROM THE ELEVATIONS ON SHEETS 1 & 2.
- 3) ANY INSTALLATION OPTION SHOWN (2X BUCK, 1X BUCK, DIRECT TO MASONRY, STEEL STUD) MAY BE USED ON ANY SIDE OF THE WINDOW.
- 4) GLASS SHOWN IS FOR ILLUSTRATIVE PURPOSES ONLY AND MAY DIFFER TO MEET DESIGN REQUIREMENTS.
- 5) FLANGE MAY BE REMOVED IN-FIELD.
- 6) SHIM THICKNESS TO BE 1/4". IF SHIMS ARE REQUIRED, SHIM AT EACH ANCHOR LOCATION.
- 7) CONCRETE ANCHOR LOCATIONS MUST BE ADJUSTED TO MAINTAIN THE MINIMUM EDGE DISTANCE TO MORTAR JOINTS. ADDITIONAL CONCRETE ANCHORS MAY BE REQUIRED TO ENSURE THE O.C. DIMENSION IS NOT EXCEEDED.

PREPARED BY A. LYNN MILLER 1070 TECHNOLOGY DRIVE N. VENICE, FL 34275 (941) 480-1600		06/15/22 Date	
WINDOOR INCORPORATED WINDOOR INCORPORATED 104 TRIPLE DIAMOND BLVD N. VENICE, FL 34275 (833) 554-5432		JENS ROSOWSKI Drawn By	
ALUMINUM FIXED WINDOW (LM)		9020TDI-LM-1	
FLANGE FRAME INSTALLATION		DWG No.	
PW9020A		3 OF 7	
Sheet		Title	

A. Lynn Miller 6/15/22
 A. LYNN MILLER, P.E.
 P.E.# 106954

A EQUAL-LEG FRAME @ HEAD
INSTALLED DIRECTLY TO SUBSTRATE

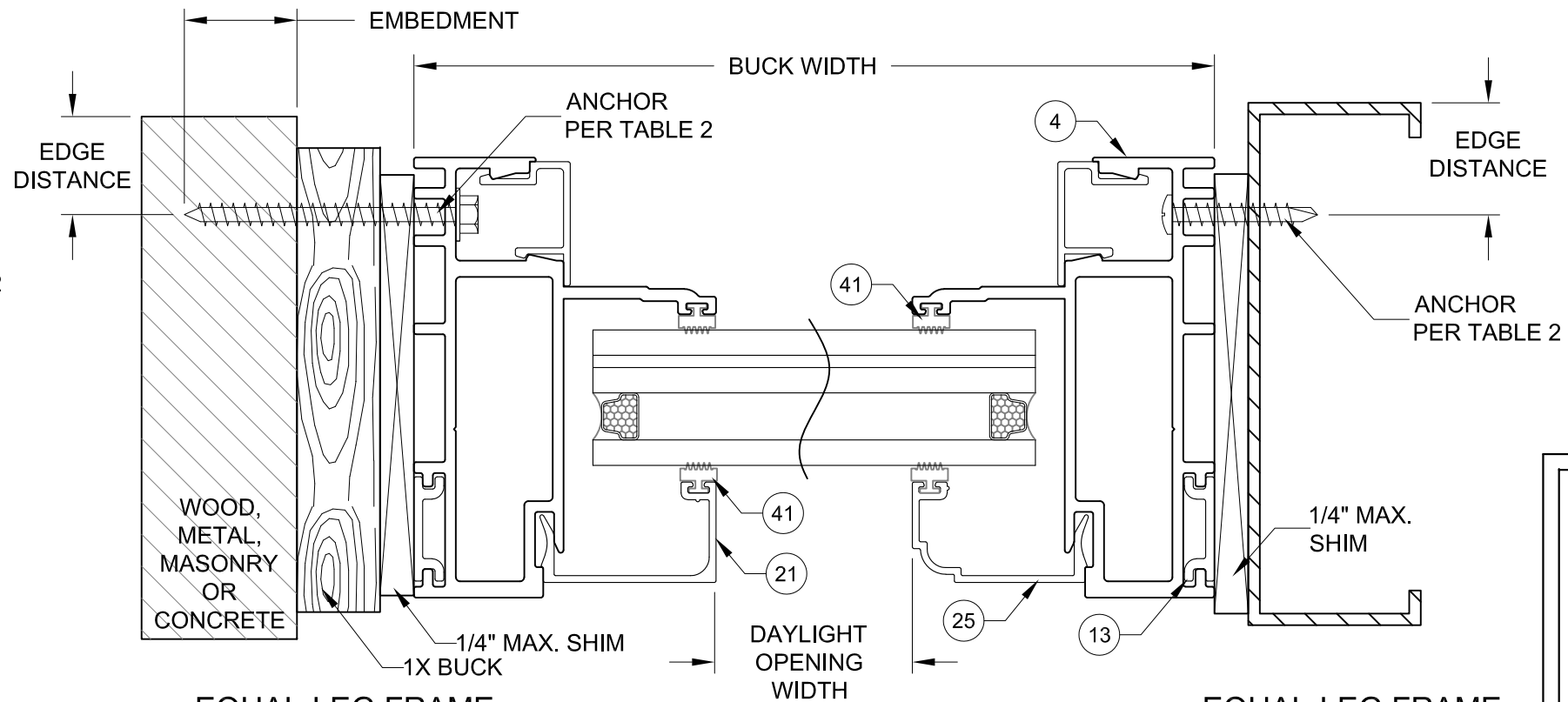
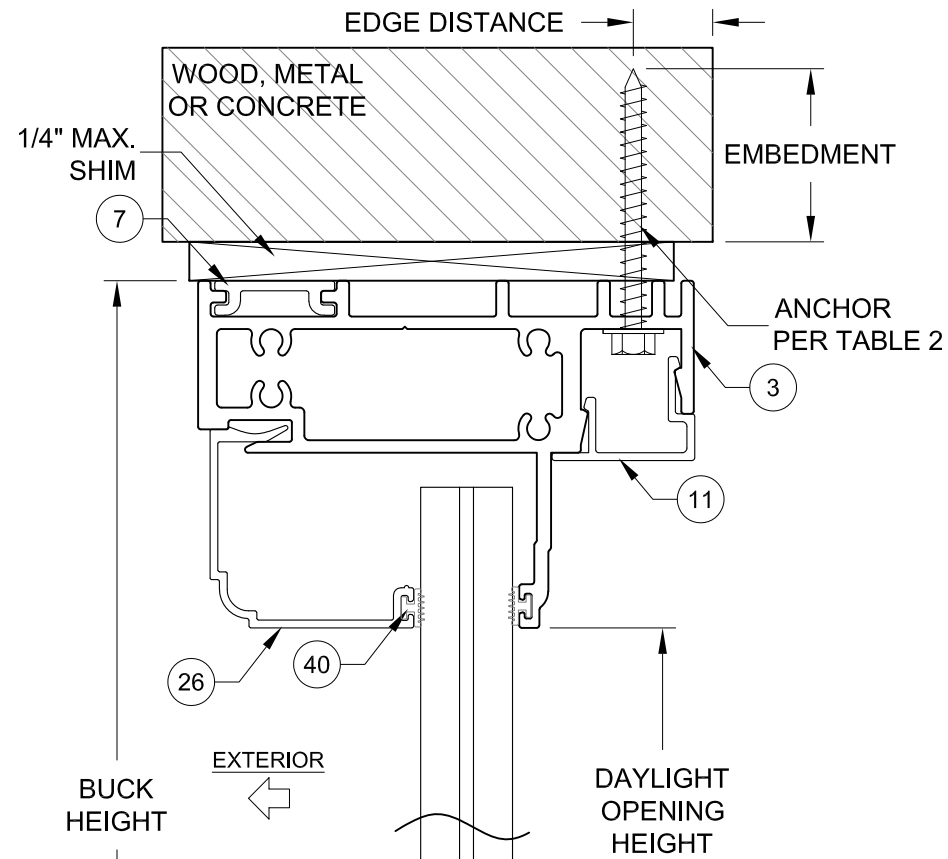

C EQUAL-LEG FRAME @ LEFT JAMB
USING 1X BUCK

D EQUAL-LEG FRAME @ RIGHT JAMB
METAL SUBSTRATE

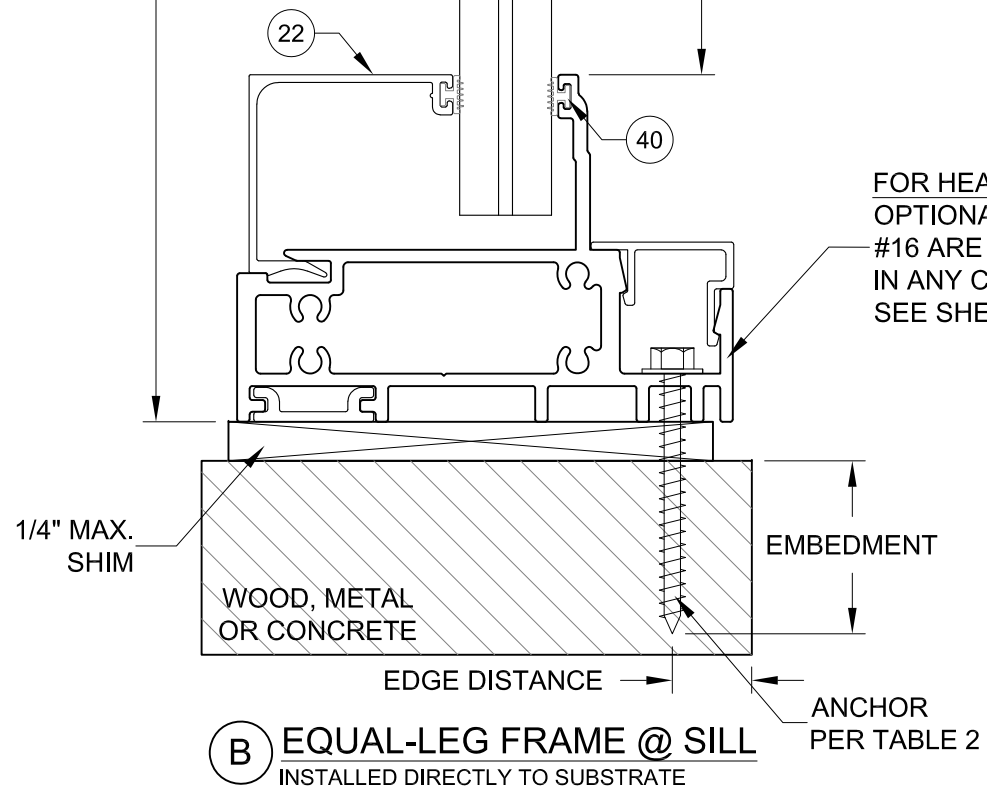

FOR HEAD AND SILL:
OPTIONAL RAILS #14, #15 &
#16 ARE ALSO APPROVED
IN ANY COMBINATIONS.
SEE SHEET 7.

INSTALLATION NOTES:

- 1) SEE SHEET 1 FOR SPACING REQUIREMENTS.
- 2) USE ONLY SUBSTRATE APPROPRIATE ANCHORS LISTED IN TABLE 2. FOLLOW EMBEDMENT AND EDGE DISTANCE DIMENSIONS FROM TABLE 1 AND O.C. DIMENSION FROM THE ELEVATIONS ON SHEETS 1 & 2.
- 3) ANY INSTALLATION OPTION SHOWN (2X BUCK, 1X BUCK, DIRECT TO MASONRY, STEEL STUD) MAY BE USED ON ANY SIDE OF THE WINDOW.
- 4) GLASS SHOWN IS FOR ILLUSTRATIVE PURPOSES ONLY AND MAY DIFFER TO MEET DESIGN REQUIREMENTS.
- 5) MAX. SHIM THICKNESS TO BE 1/4". IF SHIMS ARE REQUIRED, SHIM AT EACH ANCHOR LOCATION.
- 6) CONCRETE ANCHOR LOCATIONS MUST BE ADJUSTED TO MAINTAIN THE MINIMUM EDGE DISTANCE TO MORTAR JOINTS. ADDITIONAL CONCRETE ANCHORS MAY BE REQUIRED TO ENSURE THE O.C. DIMENSION IS NOT EXCEEDED.

PREPARED BY A. LYNN MILLER 1070 TECHNOLOGY DRIVE N. VENICE, FL 34275 (941) 480-1600		06/15/22 Date	
WINDOOR INCORPORATED WINDOOR INCORPORATED 104 TRIPLE DIAMOND BLVD N. VENICE, FL 34275 (833) 554-5432		JENS ROSOWSKI By	
ALUMINUM FIXED WINDOW (LM)		9020TDI-LM-1	
EQUAL-LEG FRAME INSTAL.		No. DWG	
PW9020A		4 OF 7	
Series Desc. Title		Sheet	

A Lynn Miller 6/15/22
A. LYNN MILLER, P.E.
P.E.# 106954

Rev.#	
Date	
Rev.	

Rev.#	
Date	
Rev.	

A FIN FRAME @ HEAD
INSTALLED DIRECTLY TO SUBSTRATE

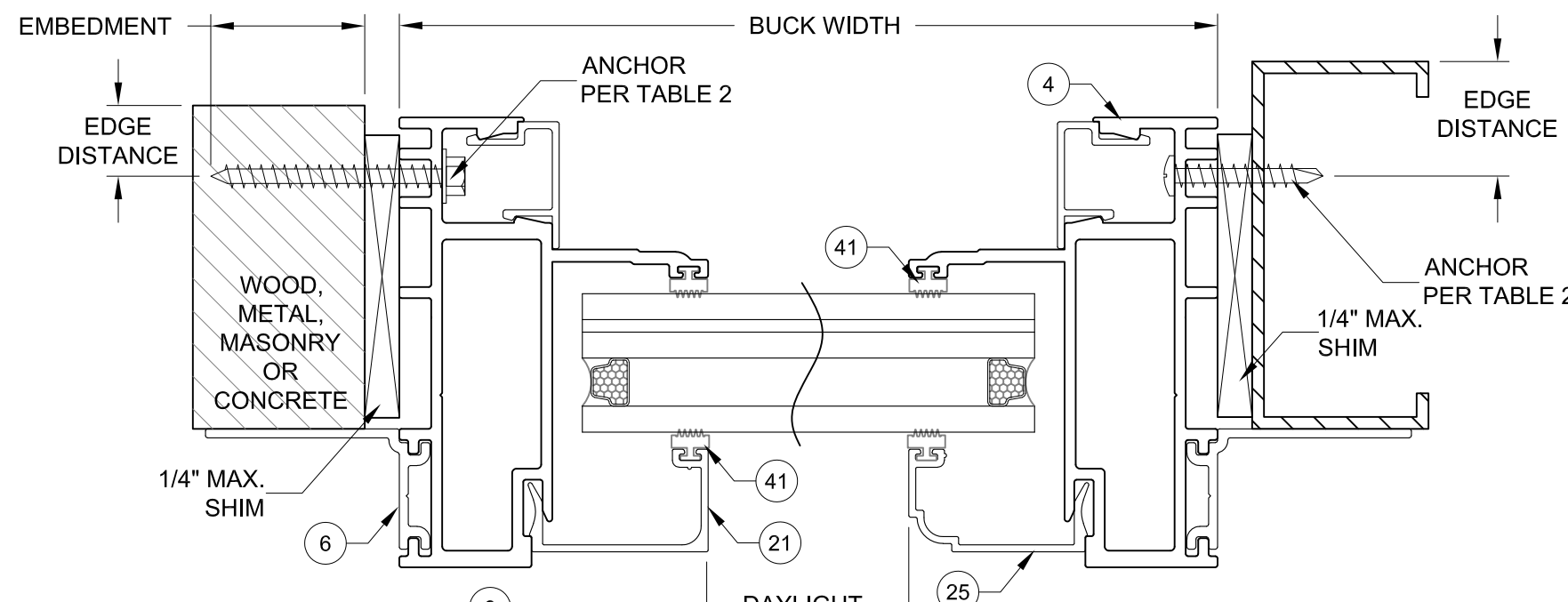
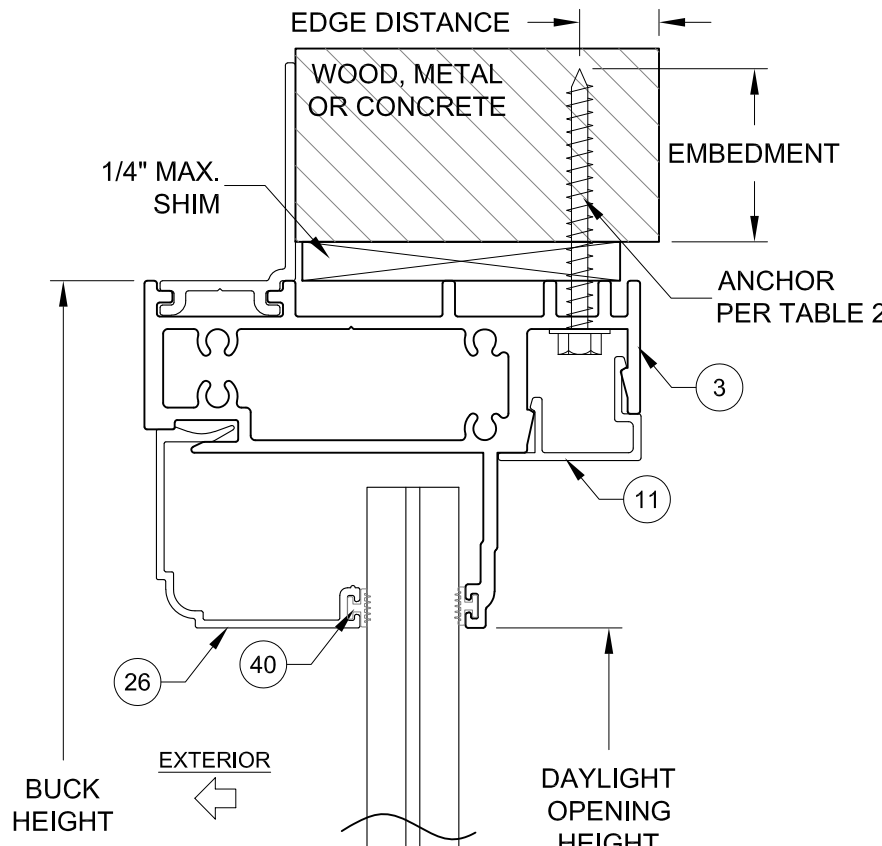

C FIN FRAME @ LEFT JAMB
INSTALLED DIRECTLY TO SUBSTRATE

D FIN FRAME @ RIGHT JAMB
METAL SUBSTRATE

FOR HEAD AND SILL:
OPTIONAL RAILS #14, #15 &
#16 ARE ALSO APPROVED
IN ANY COMBINATIONS.
SEE SHEET 7.

INSTALLATION NOTES:

- 1) SEE SHEET 1 FOR SPACING REQUIREMENTS.
- 2) USE ONLY SUBSTRATE APPROPRIATE ANCHORS LISTED IN TABLE 2. FOLLOW EMBEDMENT AND EDGE DISTANCE DIMENSIONS FROM TABLE 1 AND O.C. DIMENSION FROM THE ELEVATIONS ON SHEETS 1 & 2.
- 3) ANY INSTALLATION OPTION SHOWN (2X BUCK, 1X BUCK, DIRECT TO MASONRY, STEEL STUD) MAY BE USED ON ANY SIDE OF THE WINDOW.
- 4) GLASS SHOWN IS FOR ILLUSTRATIVE PURPOSES ONLY AND MAY DIFFER TO MEET DESIGN REQUIREMENTS.
- 5) MAX. SHIM THICKNESS TO BE 1/4". IF SHIMS ARE REQUIRED, SHIM AT EACH ANCHOR LOCATION.
- 6) CONCRETE ANCHOR LOCATIONS MUST BE ADJUSTED TO MAINTAIN THE MINIMUM EDGE DISTANCE TO MORTAR JOINTS. ADDITIONAL CONCRETE ANCHORS MAY BE REQUIRED TO ENSURE THE O.C. DIMENSION IS NOT EXCEEDED.

B FIN FRAME @ SILL
INSTALLED DIRECTLY TO SUBSTRATE

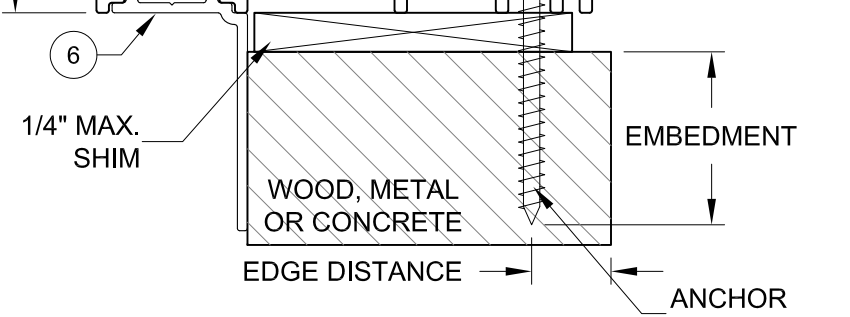

PREPARED BY A. LYNN MILLER 1070 TECHNOLOGY DRIVE N. VENICE, FL 34275 (941) 480-1600 COPYRIGHT © 2022 WINDOOR, INC., LIMITED LICENSE TO MAKE COPIES FOR PERMITTING.	Date	06/15/22
	By	JENS ROSOWSKI
WINDOOR INCORPORATED WINDOOR INCORPORATED 104 TRIPLE DIAMOND BLVD N. VENICE, FL 34275 (833) 554-5432	DWG No.	9020TDI-LM-1
	Sheet	5 OF 7
Series	Desc.	Title
PW9020A	ALUMINUM FIXED WINDOW (LM)	FIN FRAME INSTALLATION

A Lynn Miller 6/15/22
A. LYNN MILLER, P.E.
P.E.# 106954

Rev.#	
Date	
Rev.	

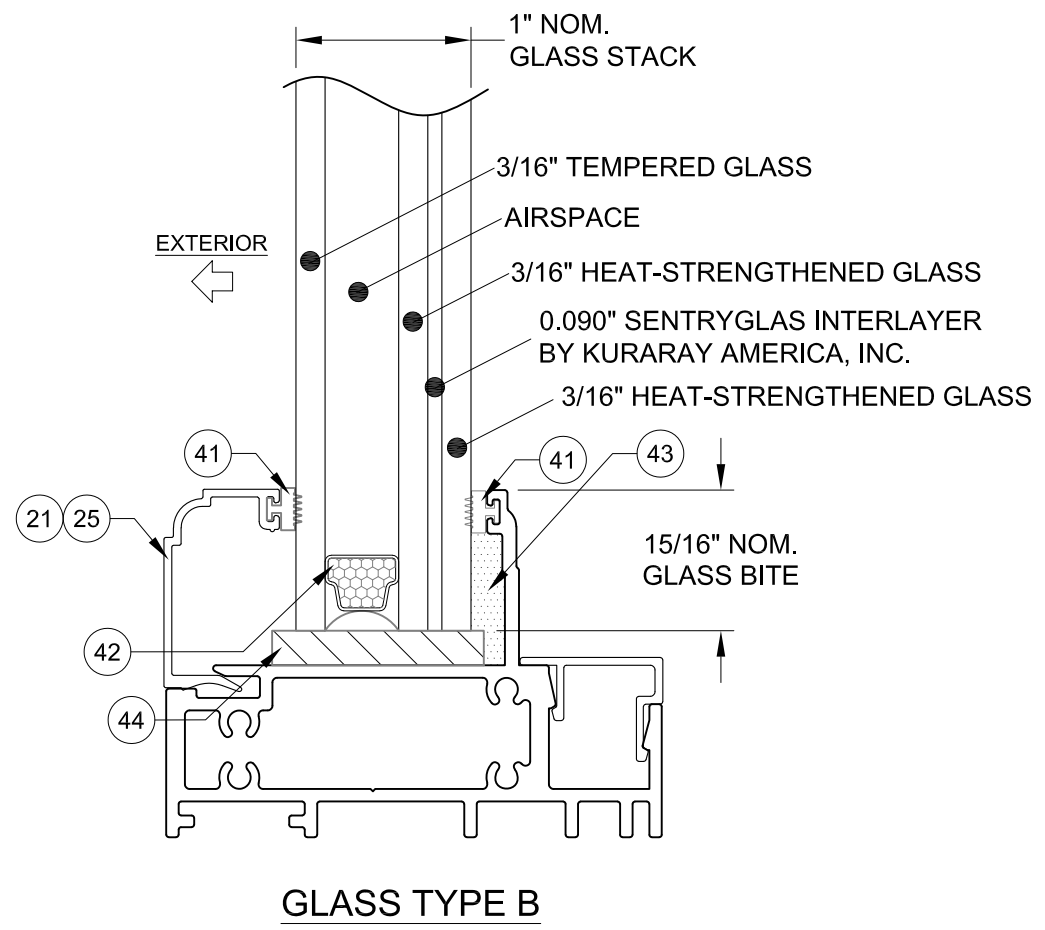
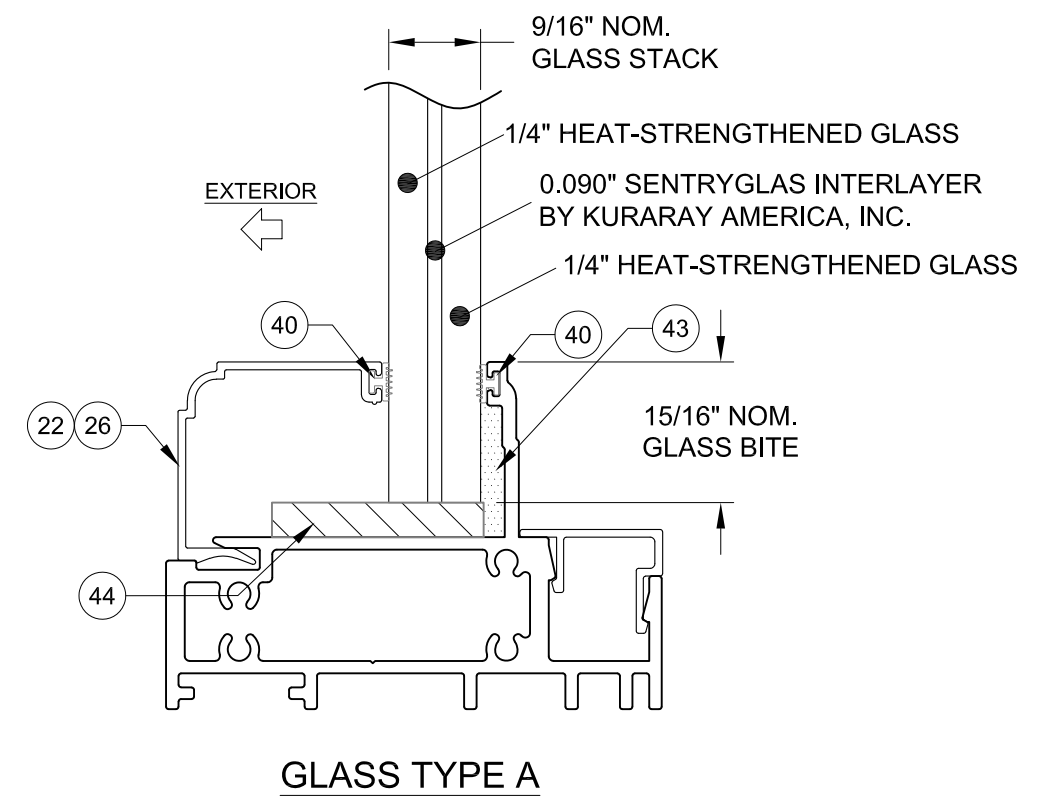
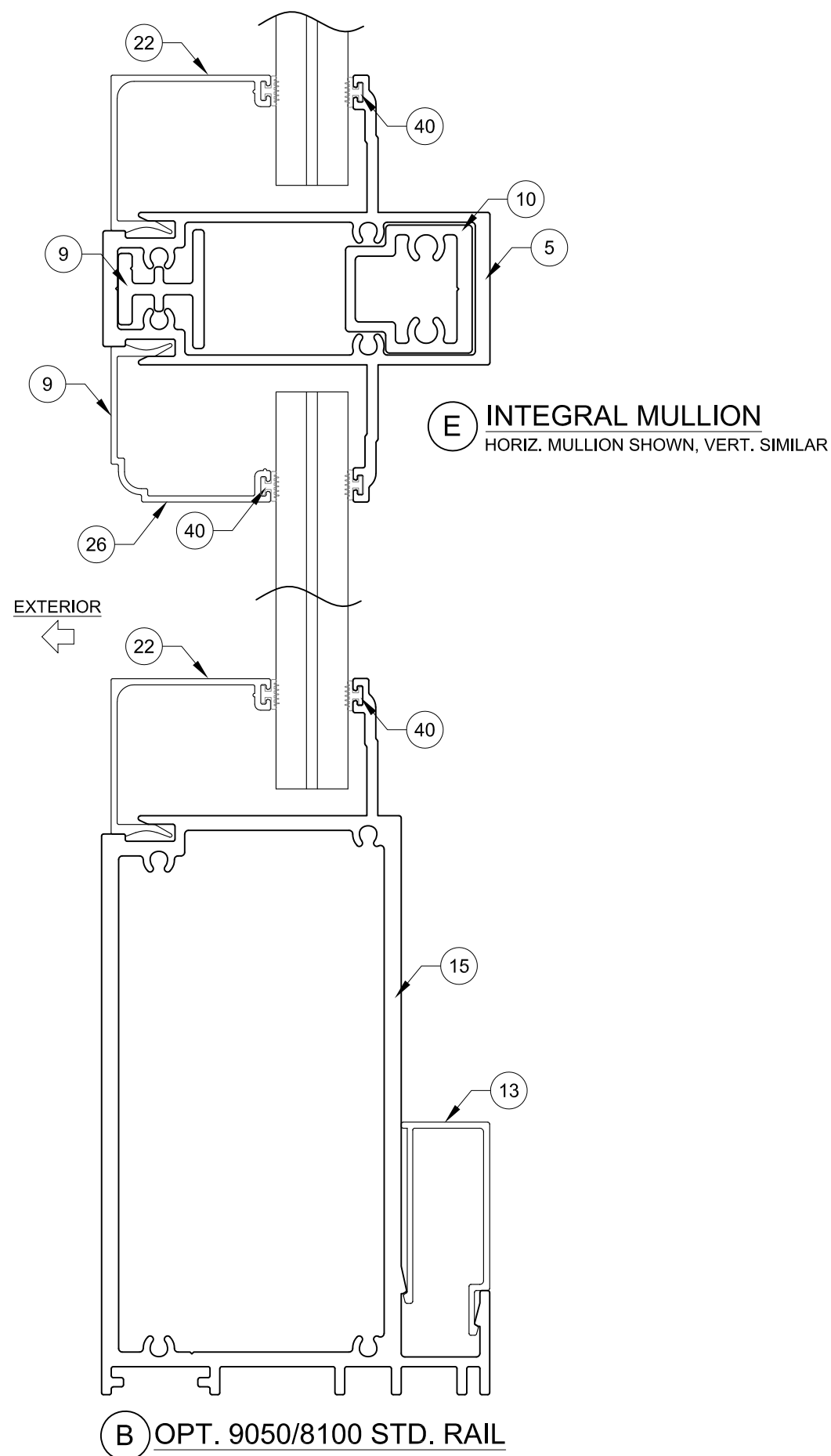

PREPARED BY A. LYNN MILLER 1070 TECHNOLOGY DRIVE N. VENICE, FL 34275 (941) 480-1600	Date	06/15/22
	By	JENS ROSOWSKI
WINDOOR INCORPORATED 104 TRIPLE DIAMOND BLVD N. VENICE, FL 34275 (833) 554-5432	DWG No.	9020TDI-LM-1
	Sheet	6 OF 7
ALUMINUM FIXED WINDOW (LM)	Desc. Title	
MULLION & GLAZING DETAILS		
PW9020A	Series	

COPYRIGHT © 2022 WINDOOR, INC., LIMITED
LICENSE TO MAKE COPIES FOR PERMITTING.

STATE OF TEXAS
ANTHONY LYNN MILLER
106954
LICENSED PROFESSIONAL ENGINEER

A Lynn Miller 6/15/22
A. LYNN MILLER, P.E.
P.E.# 106954

TABLE 3:

ITEM #	PART #	DESCRIPTION	MATERIAL
1	12012616	Flange Frame Head & Sill	ALUM. 6063-T6
2	12012615	Flange Frame Jamb	ALUM. 6063-T6
3	12012475	Equal-leg Frame Head & Sill	ALUM. 6063-T6
4	12012476	Equal-leg Frame Jamb	ALUM. 6063-T6
5	12012620	Integral Mullion	ALUM. 6063-T6
6	11049332	Fin Frame Adapter	ALUM. 6063-T6
7	11049330	Flush Frame Adapter	ALUM. 6063-T6
8	11049331	Flange Frame Adapter	ALUM. 6063-T6
9	11006558	Mullion Exterior Reinforcement	ALUM. 6063-T6
10	11006559	Mullion Interior Reinforcement	ALUM. 6063-T6
11	11049328	Std. Screw Cover	ALUM. 6063-T6
12	11052614	Med. Rail Screw Cover	ALUM. 6063-T6
13	11010417	Tall Rail Screw Cover	ALUM. 6063-T6
14	12012619	8100 Top Rail	ALUM. 6063-T6
15	12012617	9050/8100 Std. Rail	ALUM. 6063-T6
16	12012618	9050/8100 Tall Bottom Rail	ALUM. 6063-T6
21	11052598	1" Square Glass Beading	ALUM. 6063-T6
22	11052597	9/16" Square Glass Beading	ALUM. 6063-T6
25	11046084	1" OG Glass Beading	ALUM. 6063-T6
26	11049329	9/16" OG Glass Beading	ALUM. 6063-T6
28	11055400	Narrow Architectural Beading	ALUM. 6063-T6
29	11055399	Wide Architectural Beading	ALUM. 6063-T6
30	131014	#8 x 1" SMS (Frame Assembly)	Stainless Steel
31		#8 x 1-3/4" SMS (Mullion Assembly)	Stainless Steel
40	121005	Thin Glazing Vinyl, 80 +/-5 Duro.	Vinyl
41	121006	Thick Glazing Vinyl, 80 +/-5 Duro.	Vinyl
42		IG Spacer	varies
43		SikaFlex 552, Dow 791/983 Backbedding	Silicone
44		Setting Block, 85 +/-5 Duro.	Rubber

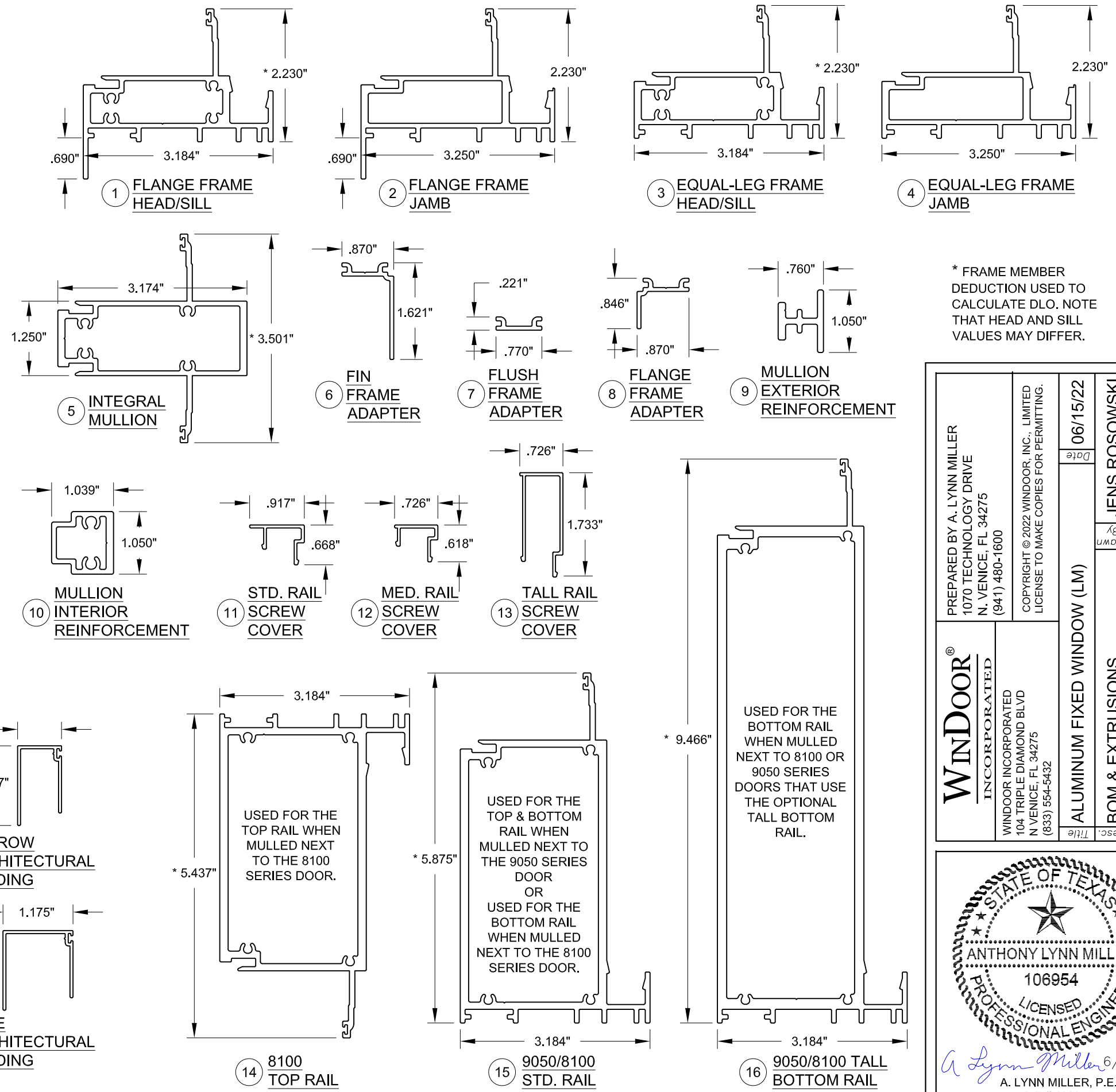

* FRAME MEMBER DEDUCTION USED TO CALCULATE DLO. NOTE THAT HEAD AND SILL VALUES MAY DIFFER.

PREPARED BY A. LYNN MILLER 1070 TECHNOLOGY DRIVE N. VENICE, FL 34275 (941) 480-1600	Date	06/15/22
	By	JENS ROSOWSKI
WINDOOR INCORPORATED 104 TRIPLE DIAMOND BLVD N. VENICE, FL 34275 (833) 554-5432	DWG No.	9020TDI-LM-1
	Sheet	7 OF 7
ALUMINUM FIXED WINDOW (LM)	Series	PW9020A
BOM & EXTRUSIONS	Desc.	

ANTHONY LYNN MILLER
106954
LICENSED PROFESSIONAL ENGINEER

A Lynn Miller 6/15/22
A. LYNN MILLER, P.E.
P.E.# 106954