

Z:\Clients\Associated PERMANENT\B - Texas Dept of Ins\Awning\WIN-XXX Series\951 Awning Impact\C - Drawings\TX-5130.dwg

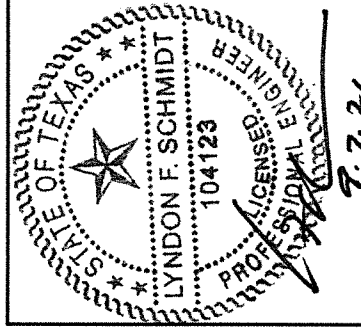
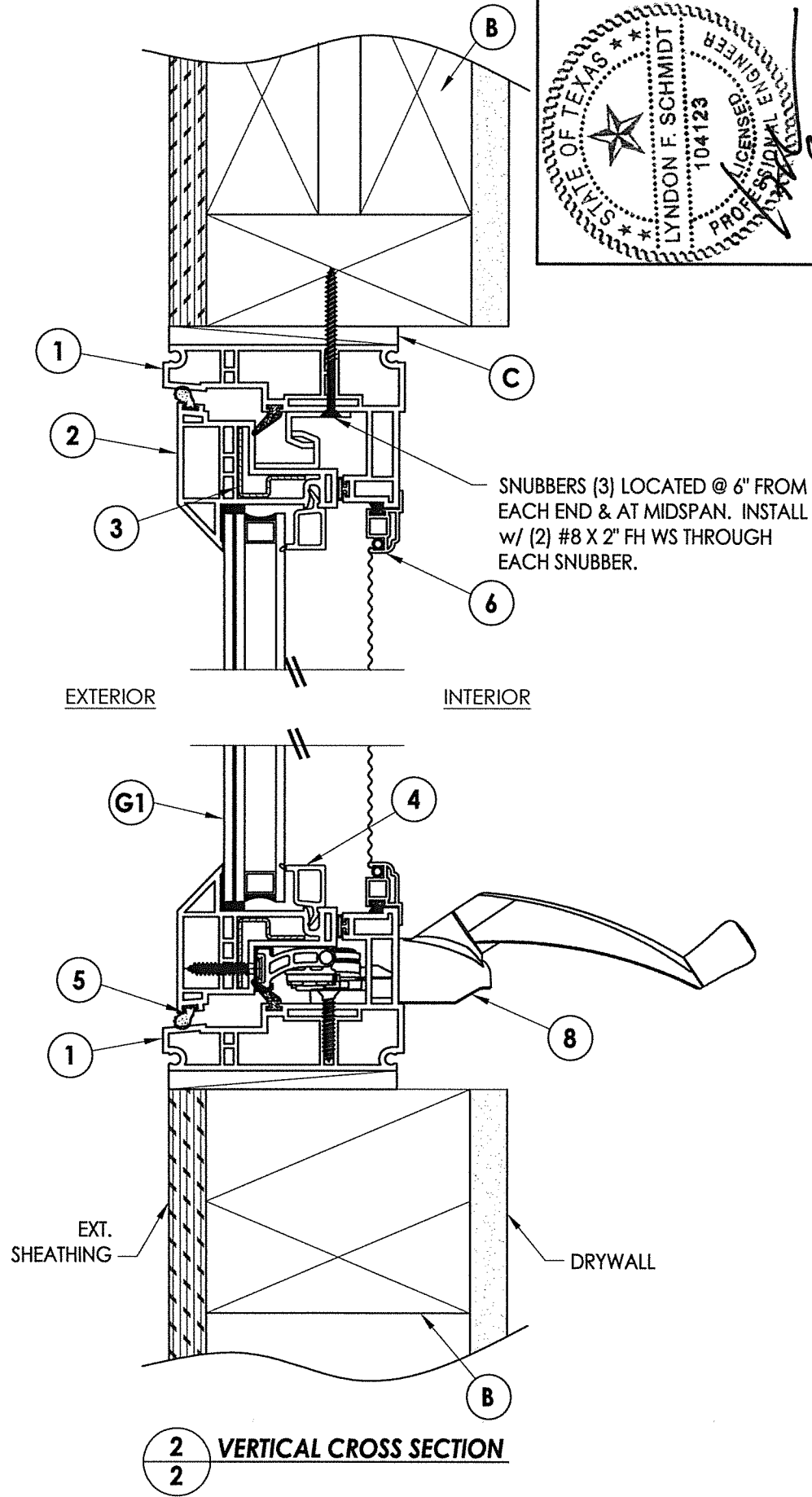
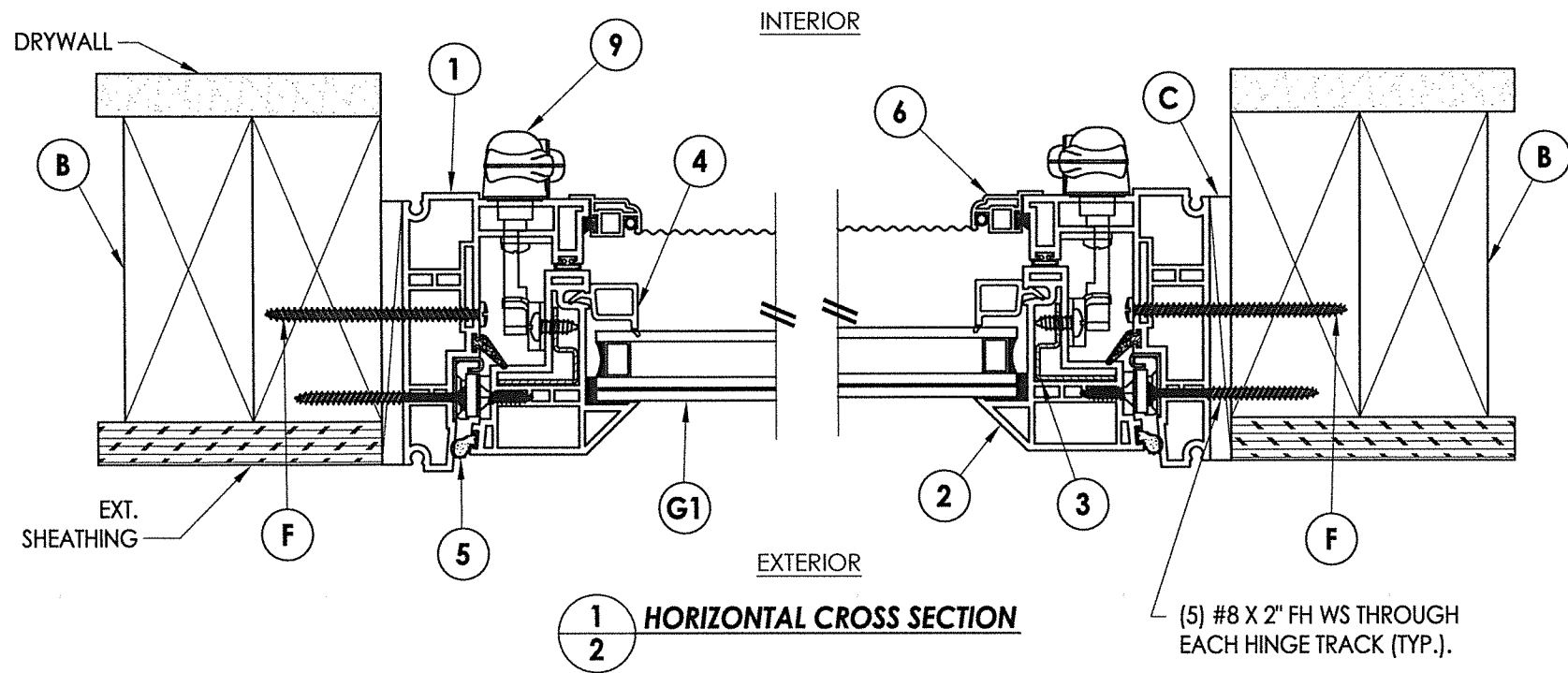
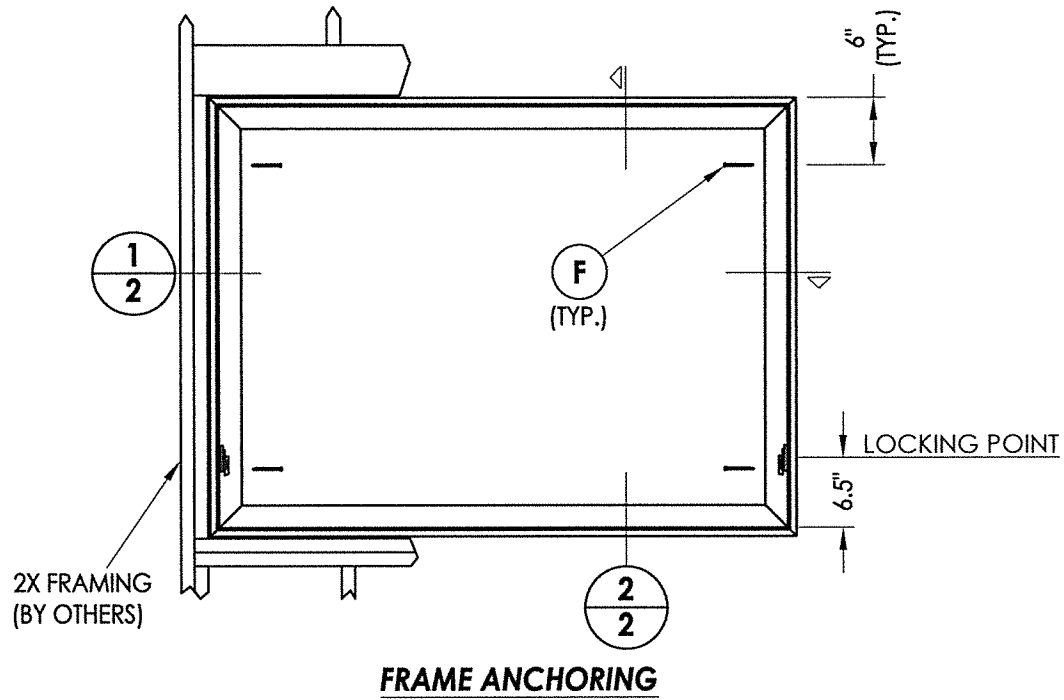

Documents Prepared By: Lyndon F. Schmidt, P.E.
TEXAS P.E. #104123

RW BUILDING CONSULTANTS, INC.
P.O. Box 230 Valrico FL 33595
Phone No.: 813.659.9197

TEXAS BOARD OF PROFESSIONAL ENGINEERS
CERTIFICATE OF REGISTRATION # F-11852

PRODUCT: AWNING WINDOW

PART OR ASSEMBLY: VERTICAL & HORIZONTAL CROSS SECTIONS & FRAME ANCHORING

NO.	DATE	BY	REVISIONS

DATE: 9/07/21
SCALE: N.T.S.
DWG. BY: RW
CHK. BY: LFS
DRAWING NO.: TX-5130
SHEET 2 OF 3

Z:\Clients\Associated PERMANENT\B - Texas Dept of Ins\Awning\WIN-XXX Series 1951 Awning ImpactC - Drawings\TX-5130.dwg

BILL OF MATERIALS

ITEM #	DESCRIPTION	MATERIAL
B	2X FRAMING (SG >= 0.42)	WOOD
C	1/4" MAX. SHIM SPACE	-
F	#10 X 2-1/2" PPH SMS (1-5/16" MIN. EMBEDMENT)	STEEL
1	MAIN FRAME*	RIGID PVC
2	SASH FRAME*	RIGID PVC
3	SASH REINFORCEMENT	STEEL
4	GLAZING BEAD*	RIGID PVC
5	WEATHERSTRIP	-
6	SCREEN	-
8	MAXIM AWNING OPERATOR BY TRUTH	-
9	LOCK HANDLE BY TRUTH	-

*THE APPROVED WHITE RIGID PVC EXTRUSIONS FOR WINDOWS ARE TO BE PRODUCED BY EXTRUDERS LICENSEES IN "AAMA CERTIFICATION PROGRAMS FOR RIGID PVC EXTRUSIONS."

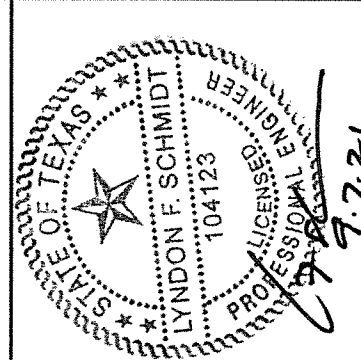

Documents Prepared By: Lyndon F. Schmidt, P.E.
TEXAS P.E. #104123

RW BUILDING CONSULTANTS, INC.
P.O. Box 230 Valrico FL 33595
Phone No.: 813.659.9197

TEXAS BOARD OF PROFESSIONAL ENGINEERS
CERTIFICATE OF REGISTRATION # F-11852

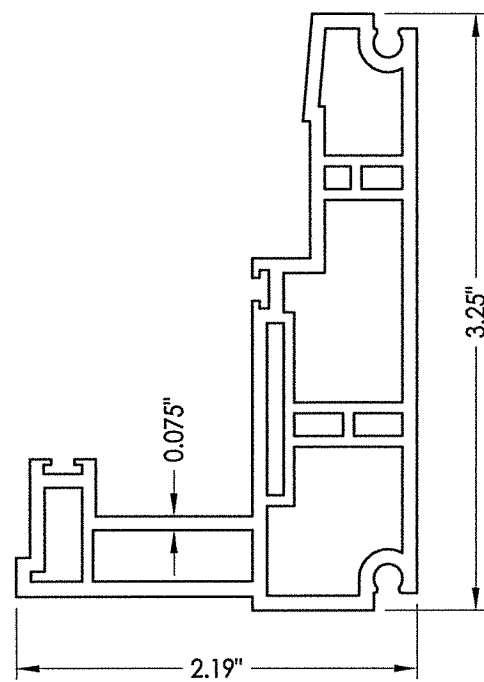

1 MAIN FRAME

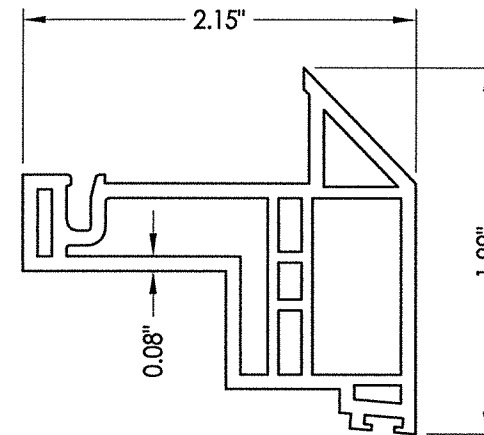

2 SASH FRAME

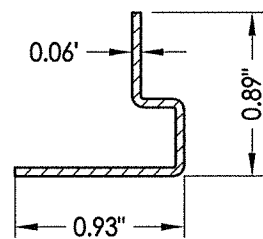

3 SASH REINFORCEMENT

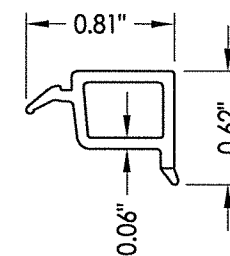

4 GLAZING BEAD

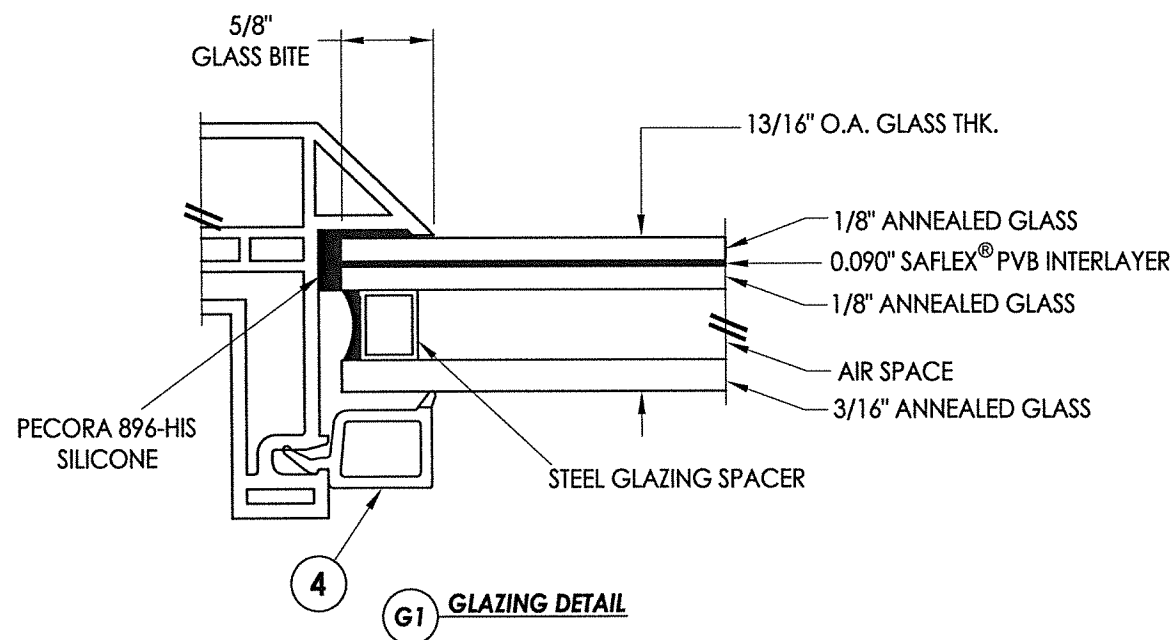

4 G1 GLAZING DETAIL

PRODUCT: AWNING WINDOW

PART OR ASSEMBLY: BILL OF MATERIALS, GLAZING DETAIL & COMPONENTS

NO.	DATE	BY	REVISIONS

DATE: 9/07/21

SCALE: N.T.S.

DWG. BY: RW

CHK. BY: LFS

DRAWING NO.: TX-5130

SHEET 3 OF 3