

# vanguard®

## "Vanguard" Series Single Hung Window "NON-IMPACT"

EVALUATED FOR USE IN THE STATE OF TEXAS

The Single Hung Window described herein complies with the 2018 International Residential Code (IRC), Sections R301 & R609 and the 2018 International Building Code (IBC), Sections 1404.13, 1609, 1709.5, 2403 and 2404 subject to the following conditions:

1. Anchors shall be as listed and spaced as shown in the details. Anchor embedment to base material shall be beyond roof covering.
2. When used in areas requiring wind-borne debris protection this product is required to be protected with an impact resistant covering that complies with Section R301.2.1.2 of the IRC and Section 1609.2 of the IBC.
3. Allowable design pressure requirements must be equal to or less than the design pressure rating shown in the design pressure chart, sheet 1 of this drawing.
4. Conditions not covered by this drawing are subject to further engineering analysis.

### TABLE OF CONTENTS

SHEET #	DESCRIPTION
1	Typical Elevations, Design Pressures & General Notes
2	Frame Anchoring & Cross Section
3	Bill of Materials, Components & Glazing Details

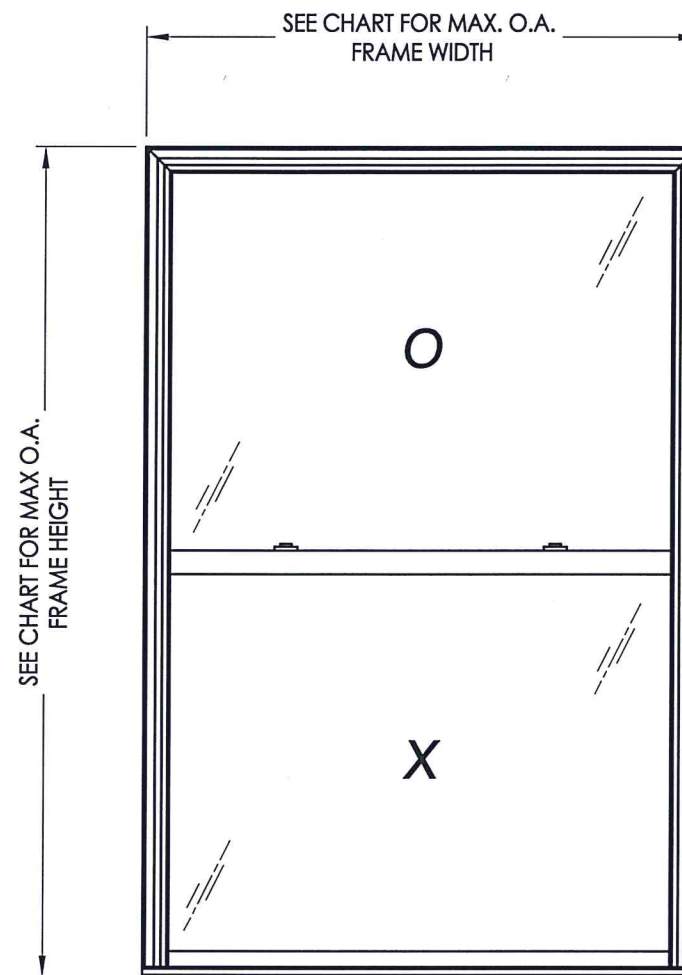

MAX. OVERALL FRAME DIMENSION	MAX DAY LITE DIMENSION (FIXED)	GLASS TYPE	DESIGN PRESSURE (PSF) w/out SILL RISER		DESIGN PRESSURE (PSF) w/ SILL RISER	
			POS.	NEG.	POS.	NEG.
49.0" X 93.0"	43.5" x 43.38"	G1	+25.0	-35.0	+25.0	-35.0
44.0" X 100.0"	38.56" x 46.88"	G1	+25.0	-35.0	+25.0	-35.0
53.0" X 83.0"	47.56" x 38.31"	G1	+25.0	-35.0	+25.0	-35.0
40.0" X 63.0"	34.5" x 28.38"	G2	+25.0	-50.0	+45.0	-50.0



Documents Prepared By: Lyndon F. Schmidt, P.E.  
TEXAS P.E. #104123

RW BUILDING CONSULTANTS, INC.  
P.O. Box 230 Valrico FL 33595  
Phone No.: 813.659.9197

TEXAS BOARD OF PROFESSIONAL ENGINEERS  
CERTIFICATE OF REGISTRATION # F-11852

PRODUCT: SINGLE HUNG WINDOW

PART OR ASSEMBLY:  
TYPICAL ELEVATION, DESIGN PRESSURES & GENERAL NOTES

NO.	DATE	BY	REVISIONS

DATE: 6/30/20

SCALE: N.T.S.

DWG. BY: RW

CHK. BY: LFS

DRAWING NO.:

TX-5078

SHEET 1 OF 3



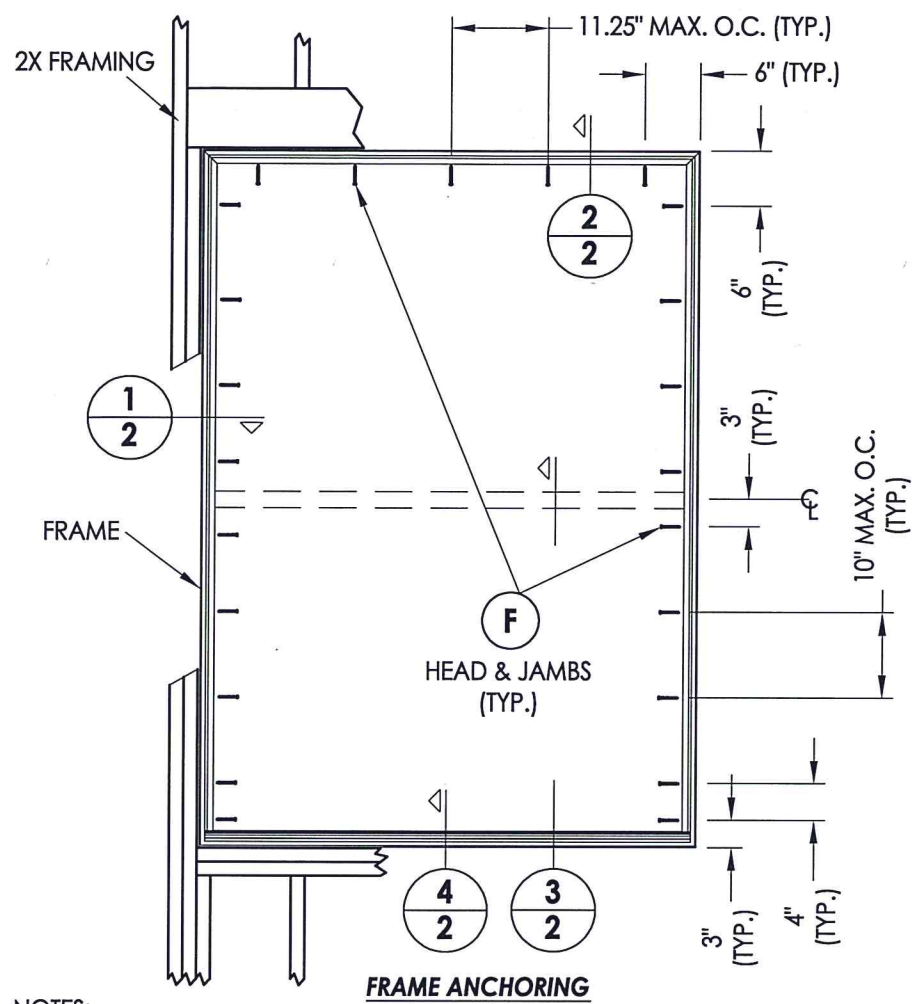

**NOTES:**

- 1. LOCK & KEEPER LOCATED 11" FROM EACH END OF LOCK/MEETING RAIL.
- 2. KEEPER RAIL REINFORCEMENT REQUIRED IN ALL SIZES.
- 3. SASH STILE & BOTTOM RAIL REINFORCEMENT REQUIRED IN ALL SIZES EXCEPT 40" X 63" FRAME SIZE.
- 4. SILL RISER REQUIRED FOR ALL POSITIVE DESIGN PRESSURES > 25 PSF.

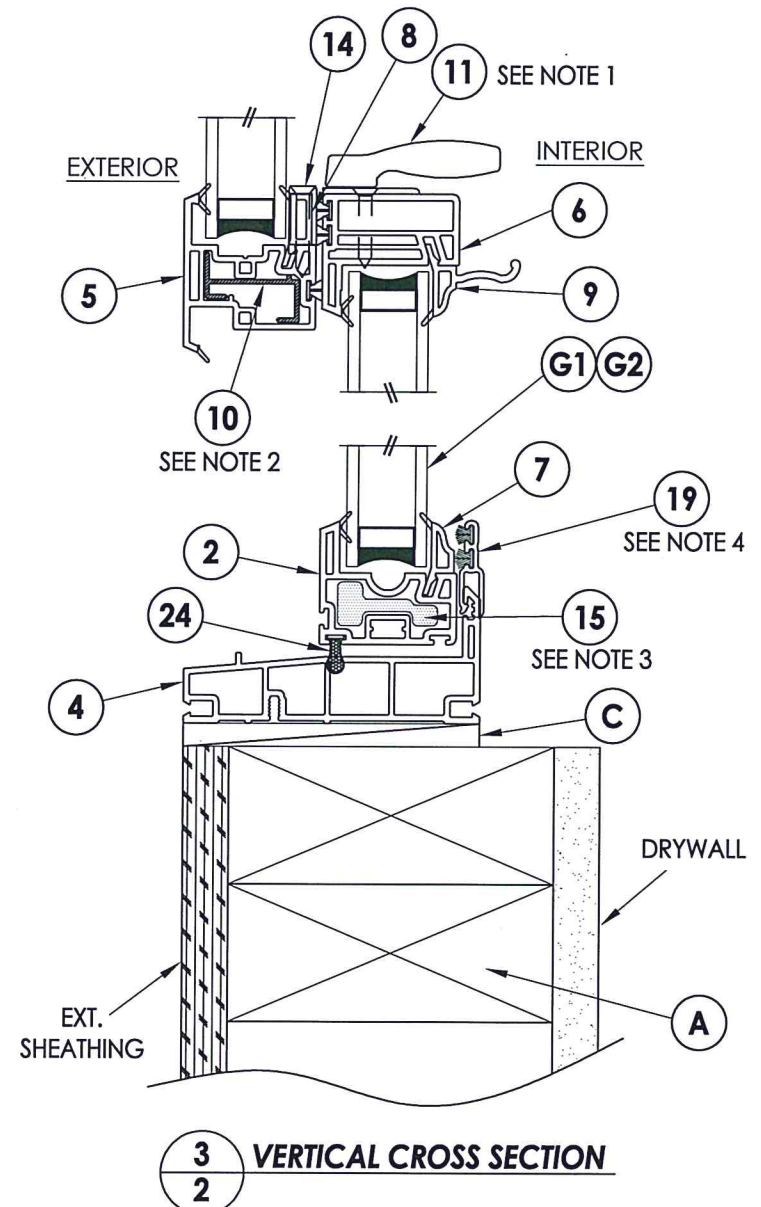
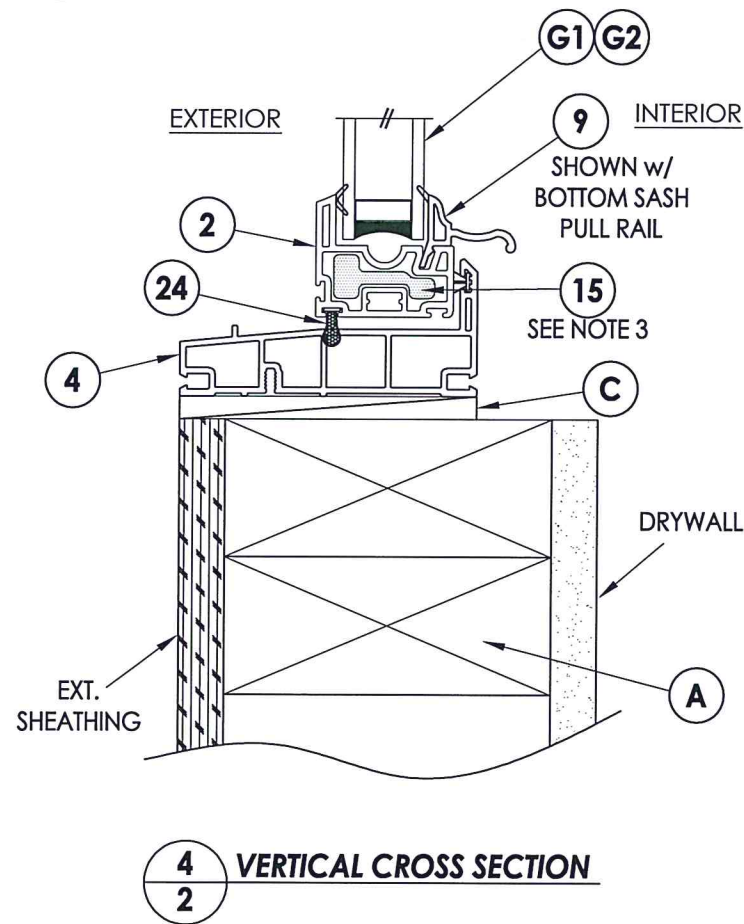
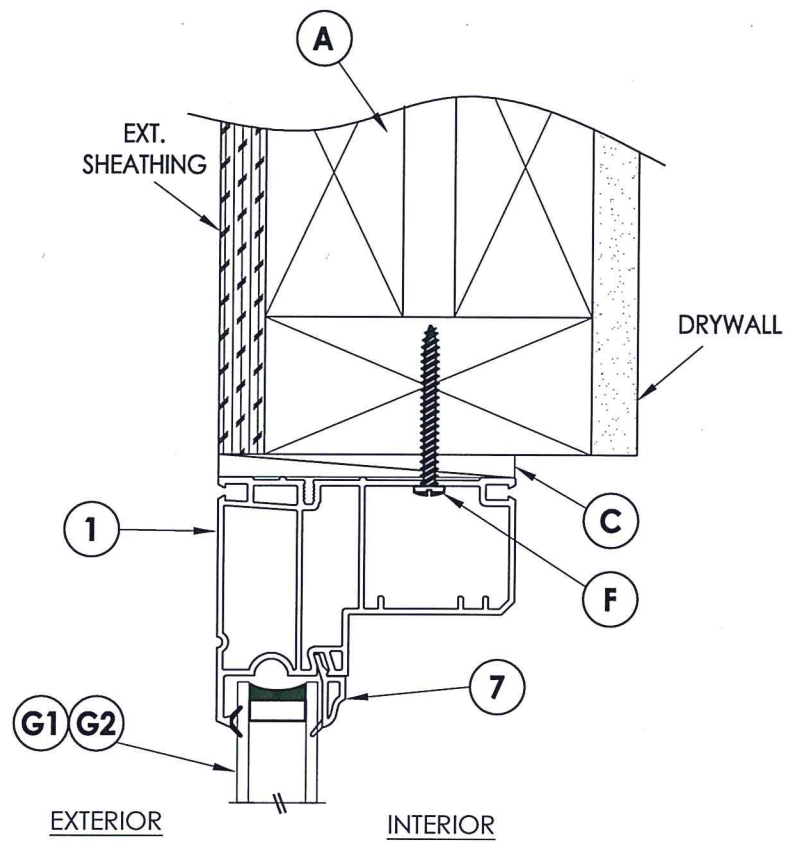
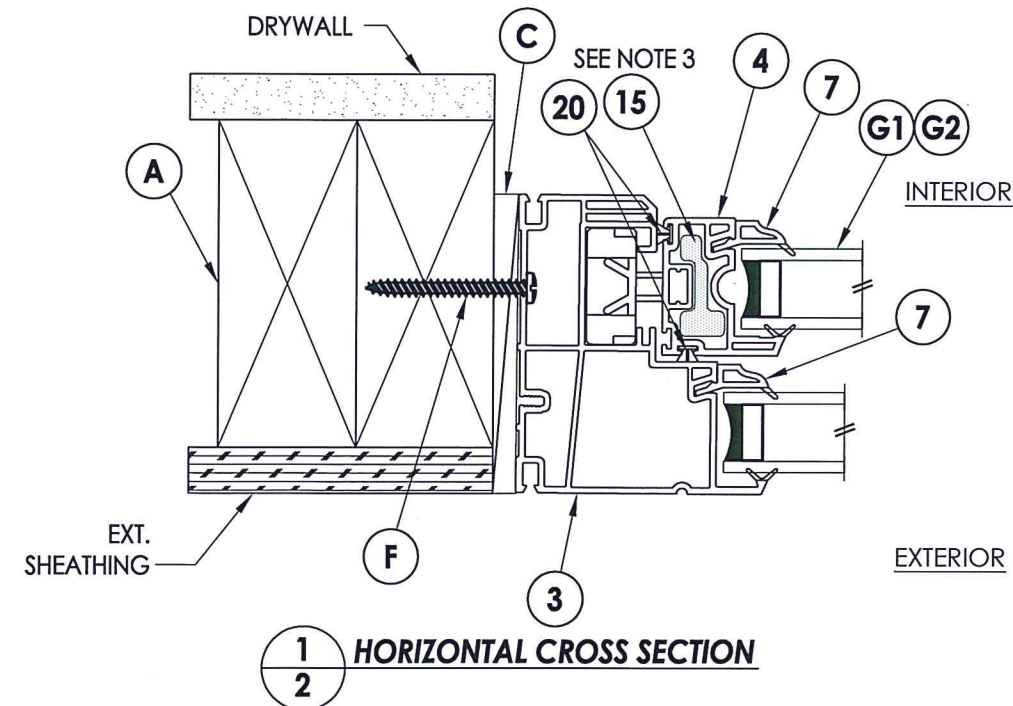

Documents Prepared By: Lyndon F. Schmidt, P.E.  
TEXAS P.E. #104123

**RW BUILDING CONSULTANTS, INC.**  
P.O. Box 230 Vairico FL 33595  
Phone No.: 813.659.9197

TEXAS BOARD OF PROFESSIONAL ENGINEERS  
CERTIFICATE OF REGISTRATION # F-11852

**PRODUCT:** SINGLE HUNG WINDOW  
**PART OR ASSEMBLY:** FRAME ANCHORING & CROSS SECTION

NO.	DATE	BY	REVISIONS

DATE: 6/30/20  
SCALE: N.T.S.  
DWG. BY: RW  
CHK. BY: LFS  
DRAWING NO.: TX-5078  
SHEET 2 OF 3



**BILL OF MATERIALS**

ITEM #	DESCRIPTION	MATERIAL
A	2X FRAMING (SG >= 0.42)	WOOD
C	1/4" MAX. SHIM SPACE	-
F	#10 X 1-3/4" PPH SMS (1-3/8" MIN. EMBEDMENT)	STEEL
1	HEAD*	RIGID PVC
2	SILL*	RIGID PVC
3	JAMB*	RIGID PVC
4	STILE/ RAIL*	RIGID PVC
5	KEEPER RAIL*	RIGID PVC
6	LOCK RAIL*	RIGID PVC
7	GLAZING BEAD* (STILE/ RAIL)	RIGID PVC
8	GLAZING BEAD* (KEEPER RAIL)	RIGID PVC
9	GLAZING BEAD* (LIFT RAIL)	RIGID PVC
10	REINFORCEMENT (KEEPER RAIL)	6063-T6 ALUM.
11	SASH LOCK	-
14	#6 X 1" PFH SMS	STEEL
15	REINFORCEMENT (STILE/RAIL)	COMP.
19	SILL RISER*	RIGID PVC
20	WEATHERSTRIP (FIN-PILE)	-
24	BULB GASKET	FOAM

\* THE APPROVED WHITE RIGID PVC EXTRUSIONS FOR WINDOWS ARE TO BE PRODUCED BY EXTRUDERS LICENSEES IN "CERTIFICATION PROGRAMS FOR RIGID PVC EXTRUSIONS".

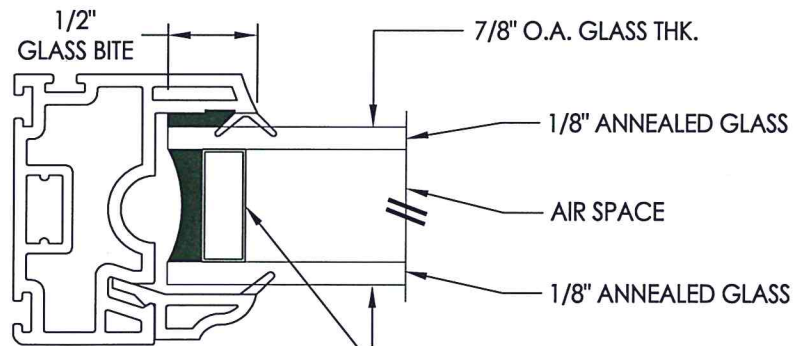

**G1 GLAZING DETAIL** - STAINLESS STEEL SPACER

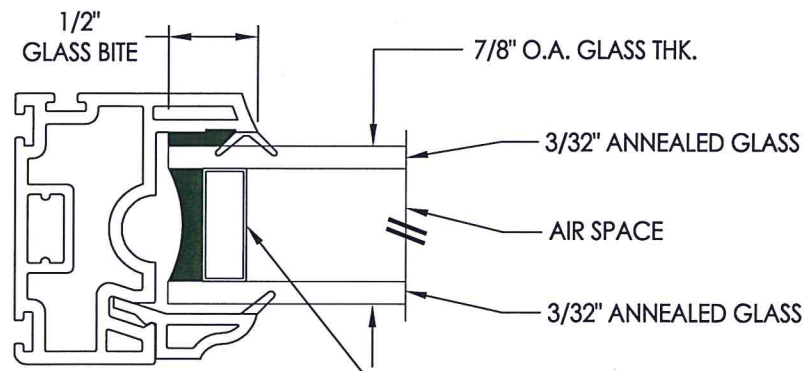

**G2 GLAZING DETAIL** - STAINLESS STEEL SPACER

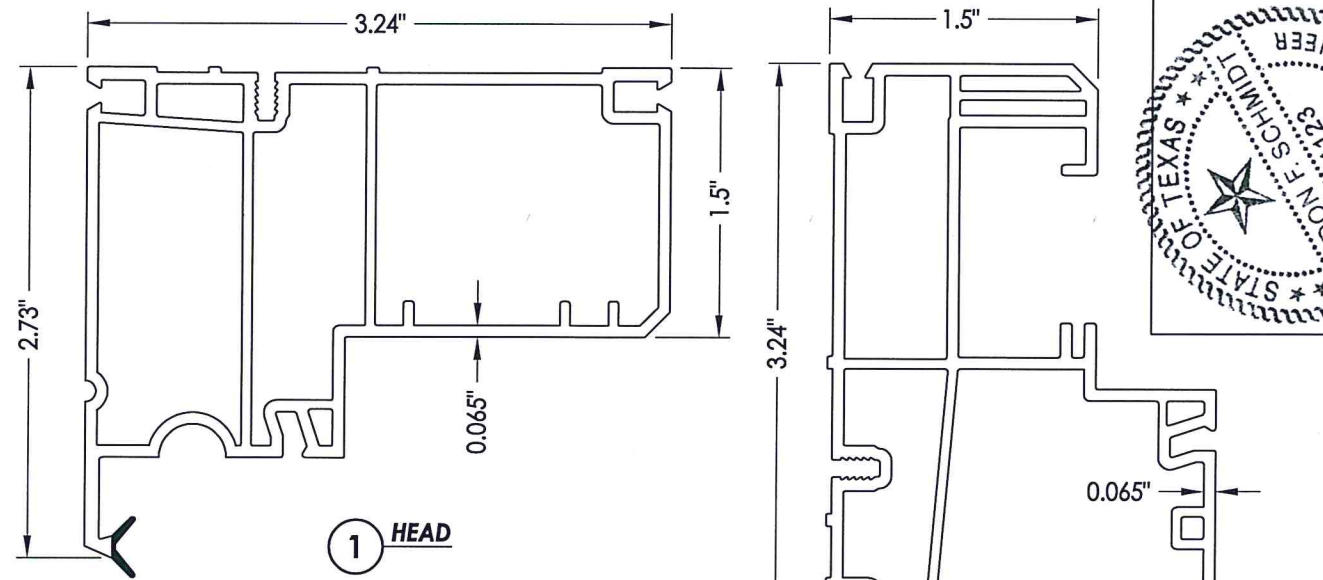

**1 HEAD**

**3 JAMB**

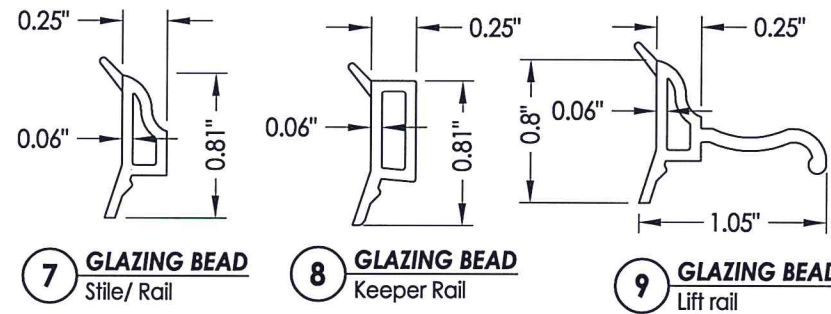

**7 GLAZING BEAD**  
Stile/ Rail

**8 GLAZING BEAD**  
Keeper Rail

**9 GLAZING BEAD**  
Lift rail

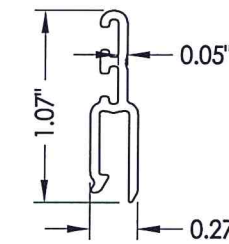

**19 SILL RISER**

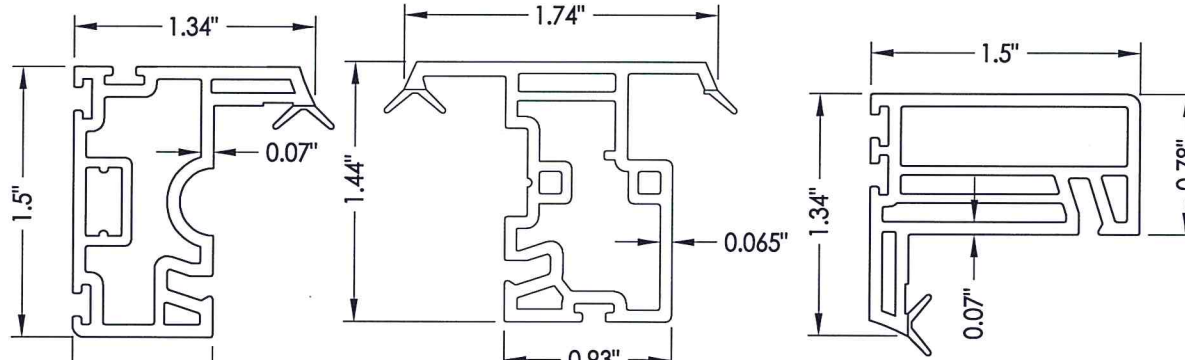

**4 STILE/RAIL**

**5 KEEPER RAIL**

**6 LOCK RAIL**

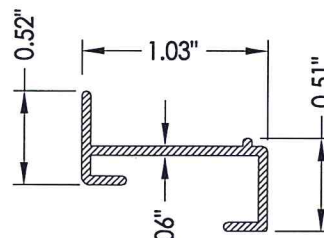

**10 REINFORCEMENT**  
Keeper Rail

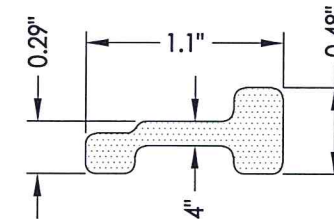

**15 REINFORCEMENT**  
Stile/ Rail

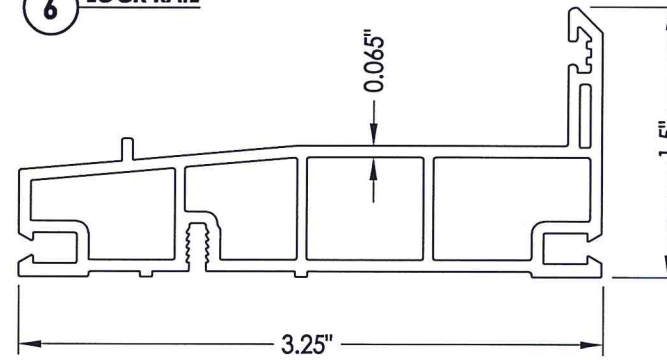

**2 SILL**

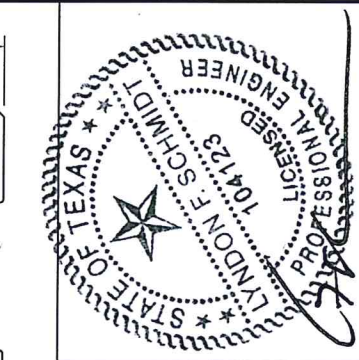

6.30.20

Documents Prepared By: Lyndon F. Schmidt, P.E.  
TEXAS P.E. #104123

**RW** BUILDING CONSULTANTS, INC.  
P.O. Box 230 Valrico FL 33595  
Phone No.: 813.659.9197

TEXAS BOARD OF PROFESSIONAL ENGINEERS  
CERTIFICATE OF REGISTRATION # F-11852

PRODUCT: SINGLE HUNG WINDOW  
PART OR ASSEMBLY: BILL OF MATERIALS  
COMPONENTS & GLAZING DETAILS

NO.	DATE	BY

DATE: 6/30/20  
SCALE: N.T.S.  
DWG. BY: RW  
CHK. BY: LFS  
DRAWING NO.: TX-5078  
SHEET 3 OF 3