

WINCORE™

WINDOWS & DOORS

250 Staunton Turnpike, Parkersburg, WV 26104

5400/5400S/7700/8400/9900 Series Vinyl Fixed Window "NON-IMPACT"

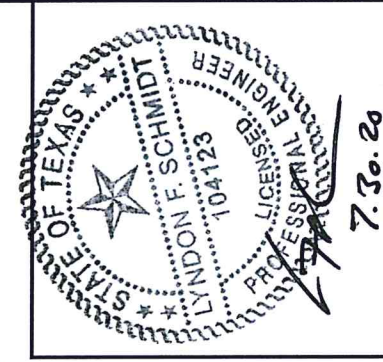
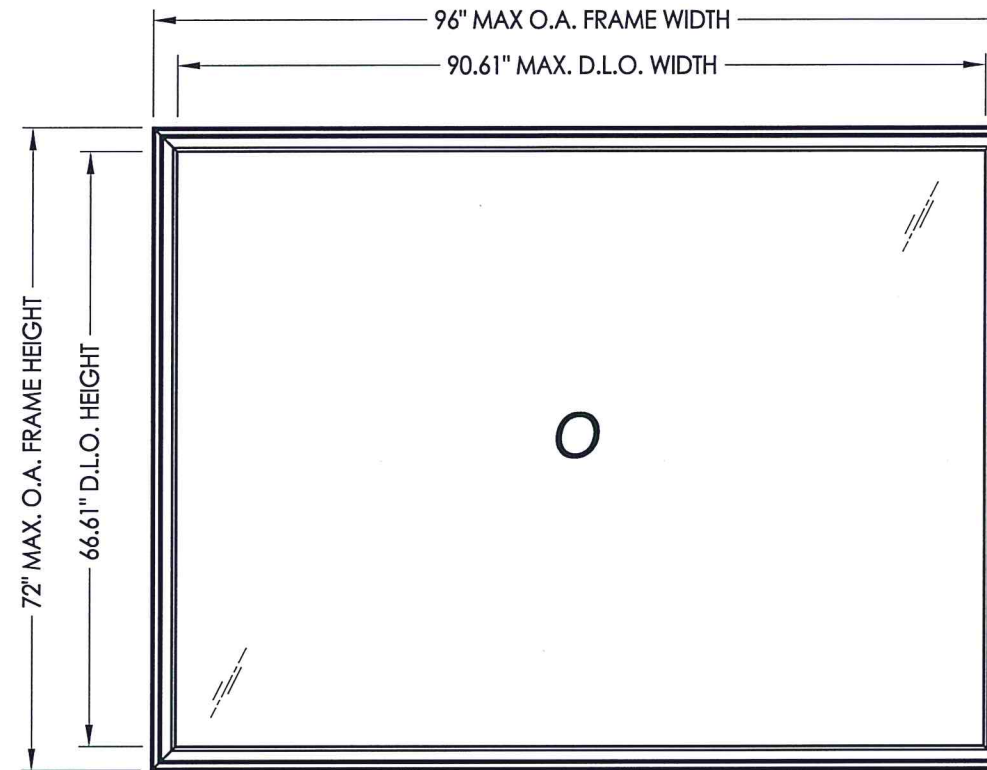

Documents Prepared By: Lyndon F. Schmidt, P.E.
TEXAS P.E. #104123

RW BUILDING CONSULTANTS, INC.
P.O. Box 230 Valrico FL 33595
Phone No.: 813.659.9197

TEXAS BOARD OF PROFESSIONAL ENGINEERS
CERTIFICATE OF REGISTRATION # F-11852

PRODUCT: FIXED WINDOW
PART OR ASSEMBLY: TYPICAL ELEVATION, DESIGN PRESSURES & GENERAL NOTES

EVALUATED FOR USE IN THE STATE OF TEXAS

The Fixed Window described herein complies with the 2018 International Residential Code (IRC), Sections R301 & R609 and the 2018 International Building Code (IBC), Sections 1404.13, 1609, 1709.5, 2403 and 2404 subject to the following conditions:

1. Anchors shall be as listed and spaced as shown in the details. Anchor embedment to base material shall be beyond wall dressing or stucco.
2. When used in areas requiring wind-borne debris protection this product is required to be protected with an impact resistant covering that complies with Section R301.2.1.2 of the IRC and Section 1609.2 of the IBC.
3. Allowable design pressure requirements must be equal to or less than the design pressure rating shown in the design pressure chart, sheet 1 of this drawing.
4. Conditions not covered by this drawing are subject to further engineering analysis.

NOTE: HORIZONTAL OR VERTICAL ORIENTATION IS ALLOWED

MAX. FRAME DIMENSION	MAX. D.L.O. DIMENSION	GLASS TYPE	DESIGN PRESSURE (PSF)	
			POSITIVE	NEGATIVE
96.0" X 72.0"	90.61" X 66.61"	G1, G4	+50.0	-50.0
72.0" X 48.0"	66.61" X 42.61"	G2, G5	+50.0	-50.0
60.0" X 60.0"	54.61" X 54.61"	G2, G5	+50.0	-50.0
86.0" X 56.0"	80.61" X 50.61"	G3, G6	+50.0	-50.0
76.0" X 64.0"	70.61" X 58.61"	G3, G6	+50.0	-50.0
74.0" X 63.0"	68.61" X 57.61"	G1, G4	+75.0	-75.0

TABLE OF CONTENTS

SHEET #	DESCRIPTION
1	Typical Elevations, Design Pressures & General Notes
2	Cross Section
3	Frame Anchoring
4	Glazing Details
5	Bill of Materials & Components

NO.	DATE	BY	REVISIONS

DATE: 7/30/20
SCALE: N.T.S.
DWG. BY: RW
CHK. BY: LFS
DRAWING NO.: TX-5089
SHEET 1 OF 5

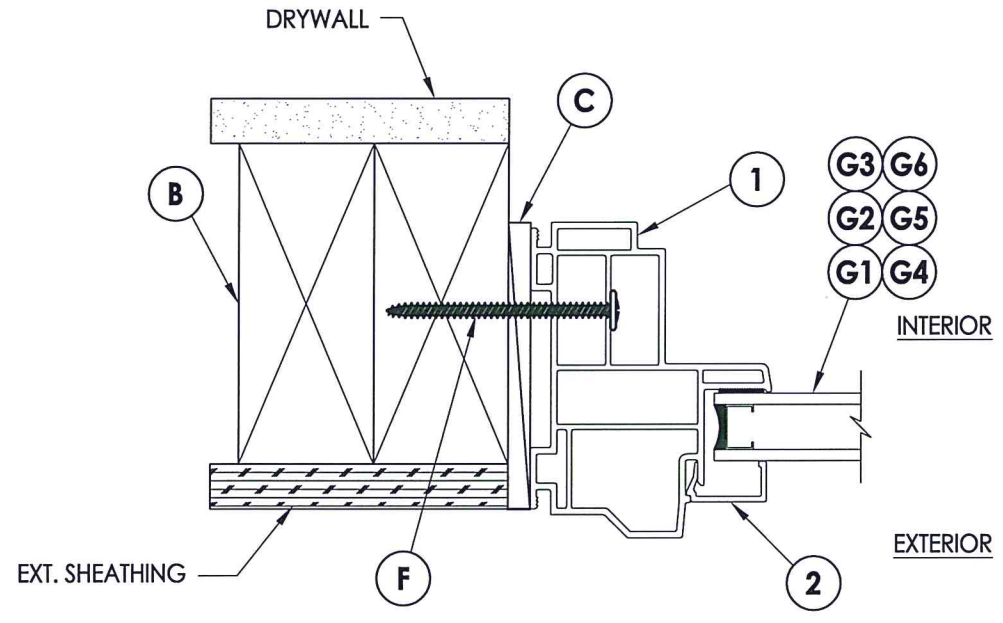
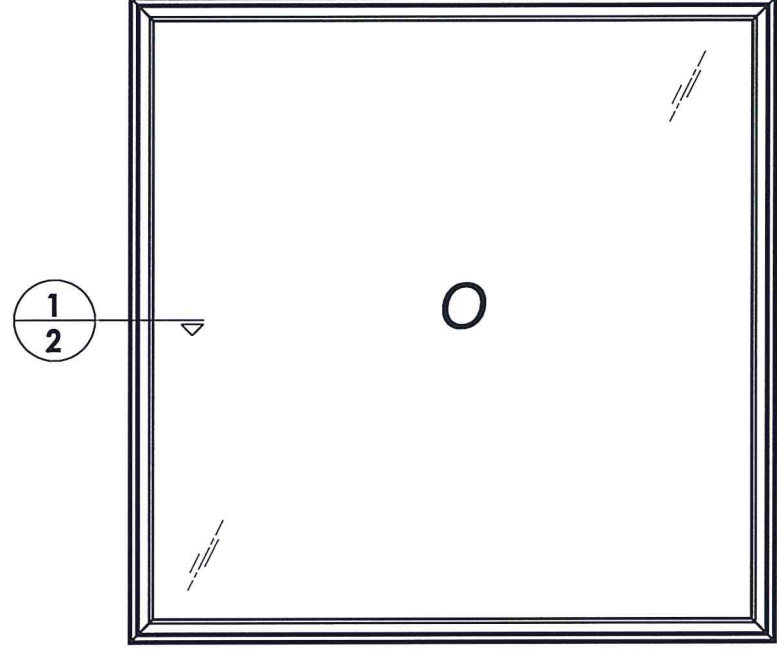

1
2 HORIZONTAL CROSS SECTION



Documents Prepared By: Lyndon F. Schmidt, P.E.
TEXAS P.E. #104123

RW BUILDING CONSULTANTS, INC.
P.O. Box 230 Vairico FL, 33595
Phone No.: 813.659.9197

TEXAS BOARD OF PROFESSIONAL ENGINEERS
CERTIFICATE OF REGISTRATION # F-11852

PRODUCT: FIXED WINDOW

PART OR ASSEMBLY: CROSS SECTION

NO.	DATE	REVISIONS	BY

DATE: 7/30/20

SCALE: N.T.S.

DWG. BY: RW

CHK. BY: LFS

DRAWING NO.: TX-5089

SHEET 2 of 5

R:\Clients\Wincore PERMANENT\B - (2018) Texas Dept of Ins\TDI XXX 5400.5400S.7700.8400.9900 FW/C - Drawings\TX-5089.dwg, 1-3

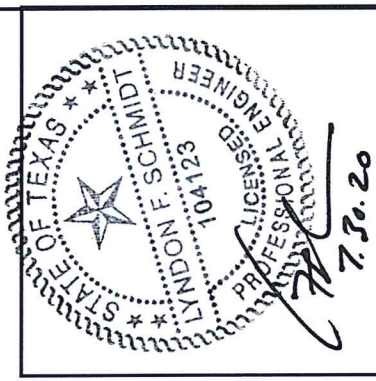
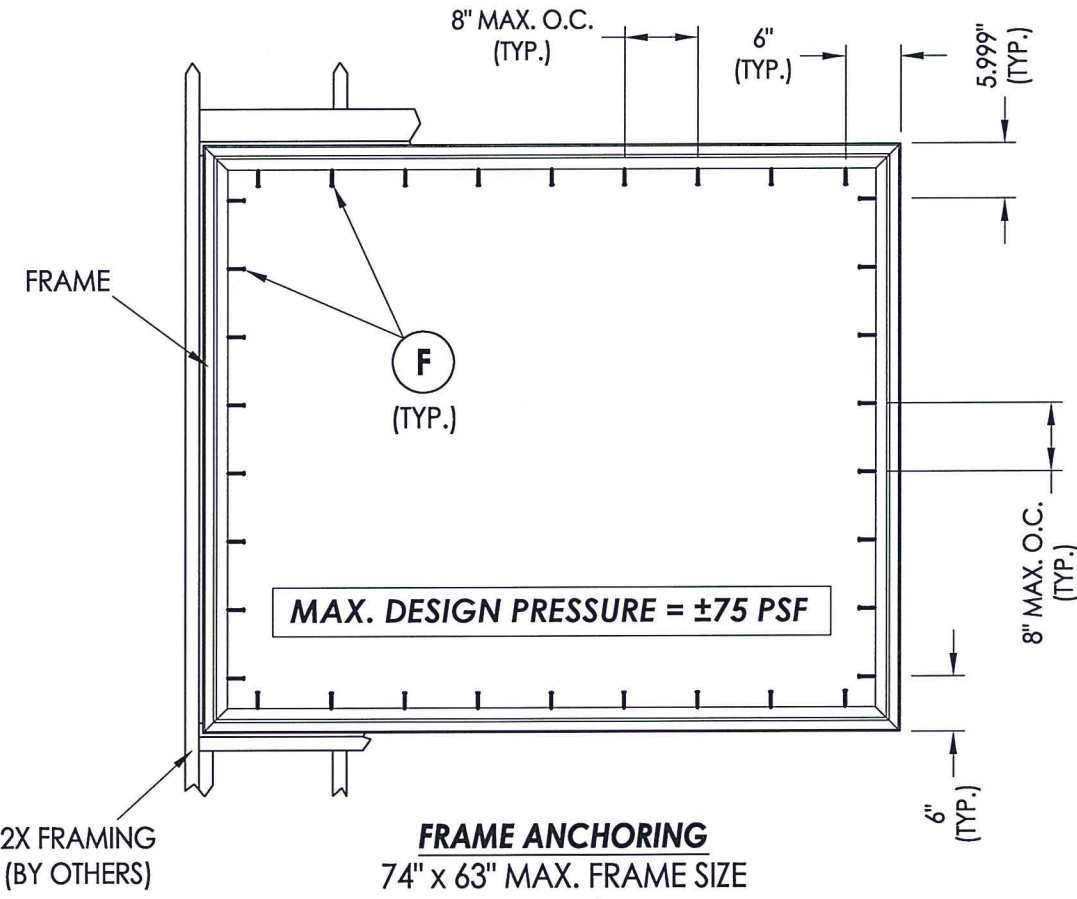
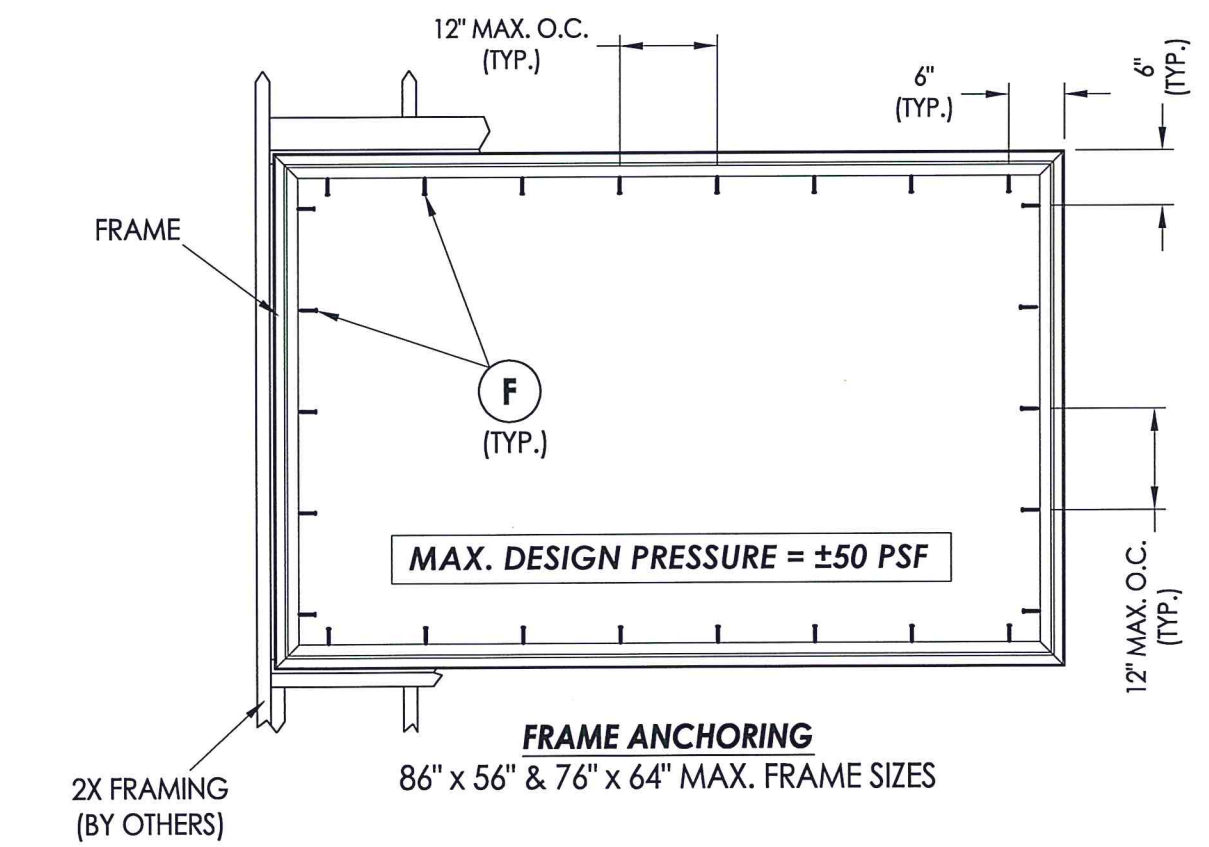
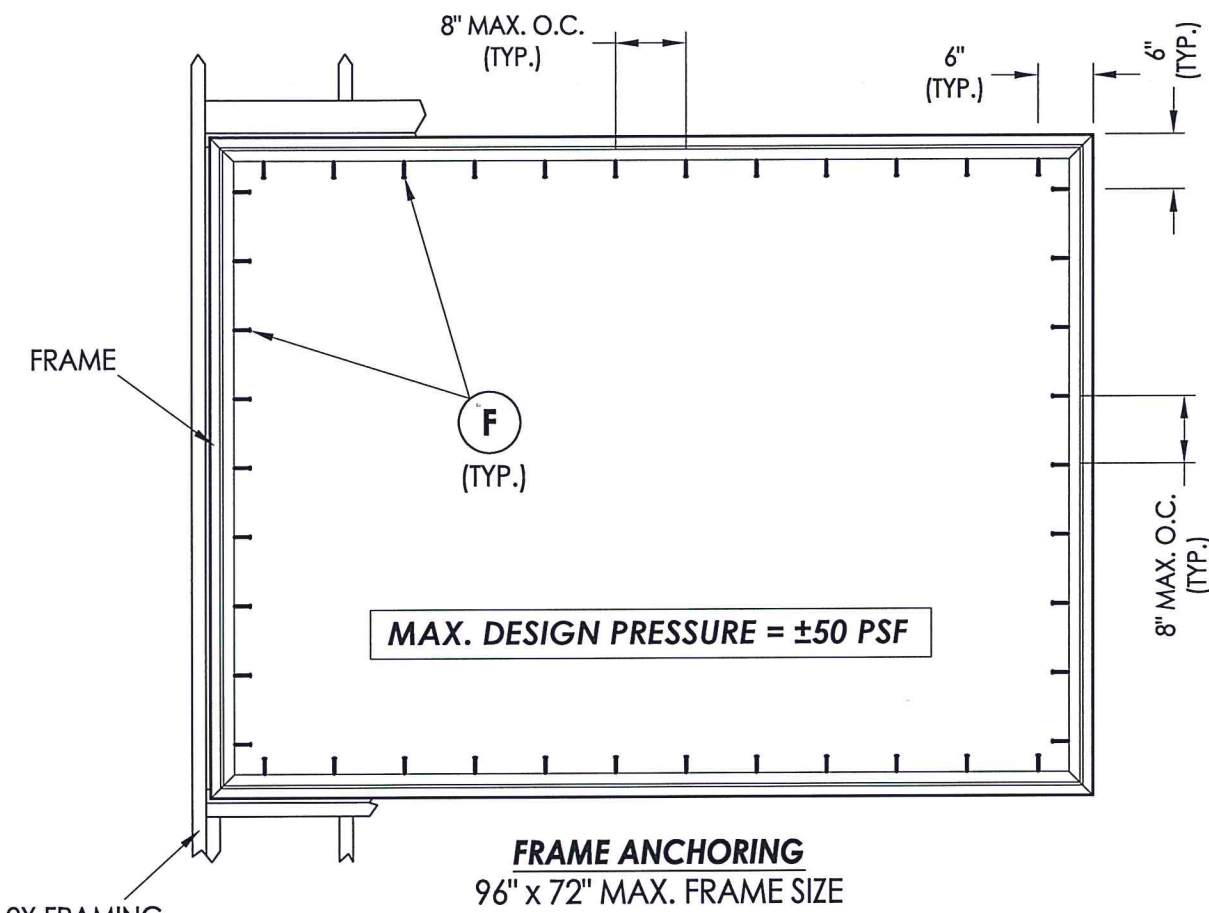

Documents Prepared By: Lyndon F. Schmidt, P.E.
TEXAS P.E. #104123

RW BUILDING CONSULTANTS, INC.
P.O. Box 230 Valrico FL, 33595
Phone No.: 813.659.9197

TEXAS BOARD OF PROFESSIONAL ENGINEERS
CERTIFICATE OF REGISTRATION # F-11852

PRODUCT:	FIXED WINDOW
PART OR ASSEMBLY:	FRAME ANCHORING

NO.	DATE	BY	REVISIONS

DATE: 7/30/20
SCALE: N.T.S.
DWG. BY: RW
CHK. BY: LFS
DRAWING NO.: TX-5089
SHEET 3 OF 5

R:\Clients\Wincore PERMANENT\B - (2018) Texas Dept of Ins\TDI XXX 5400.5400S.7700.8400.9900 FWVC - Drawings\TX-5089.dwg, 1-4

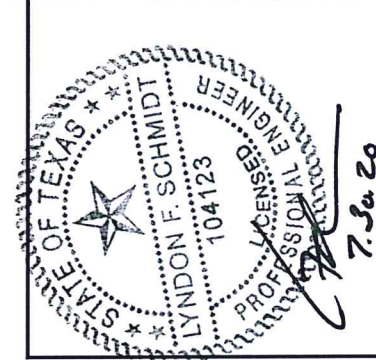

Documents Prepared By: Lyndon F. Schmidt, P.E.
TEXAS P.E. #104123

RW BUILDING CONSULTANTS, INC.
P.O. Box 230 Vairico FL, 33595
Phone No.: 813.659.9197

TEXAS BOARD OF PROFESSIONAL ENGINEERS
CERTIFICATE OF REGISTRATION # F-11852

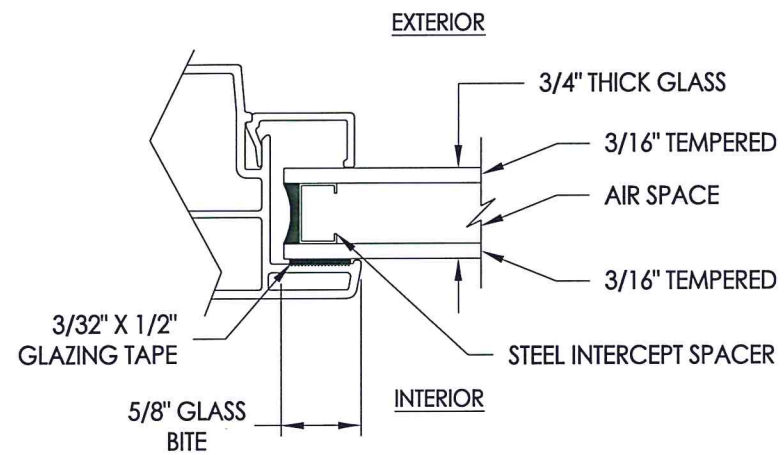

G1 GLAZING DETAIL

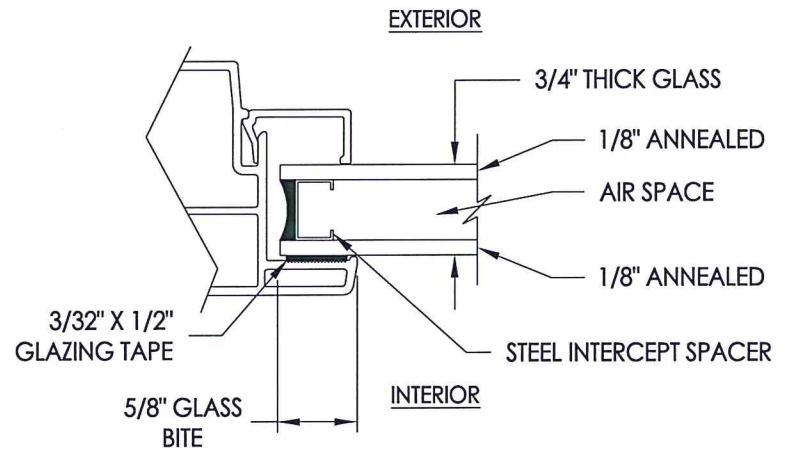

G2 GLAZING DETAIL

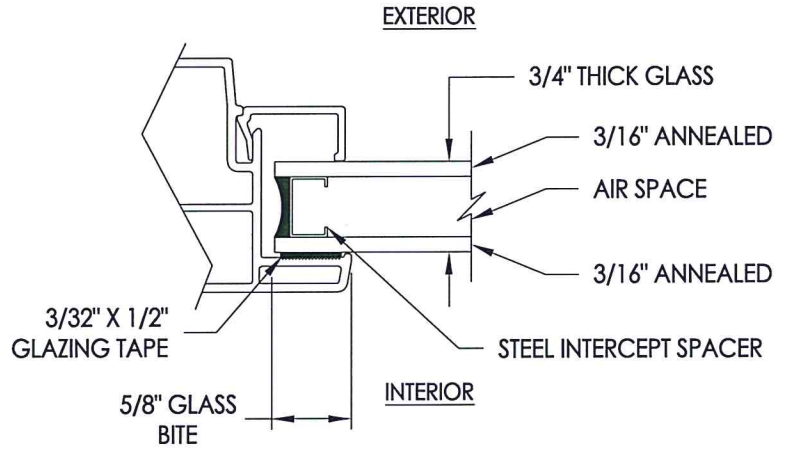

G3 GLAZING DETAIL

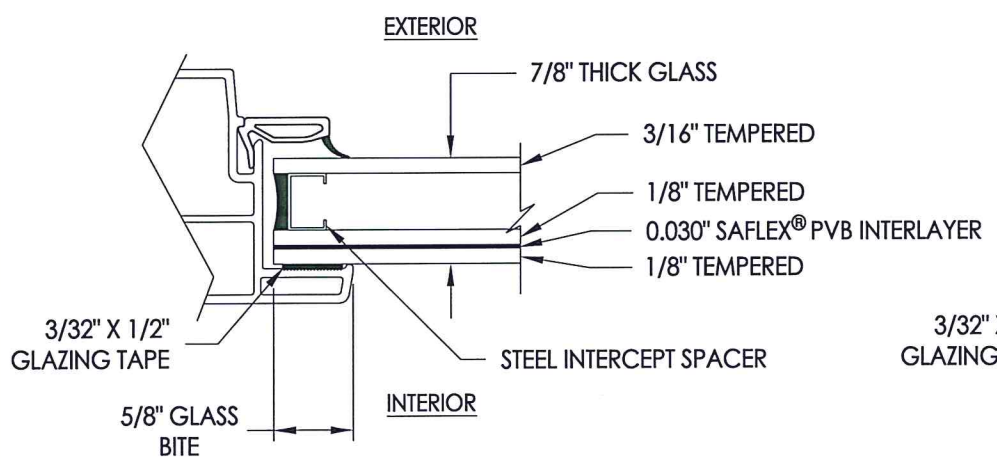

G4 GLAZING DETAIL

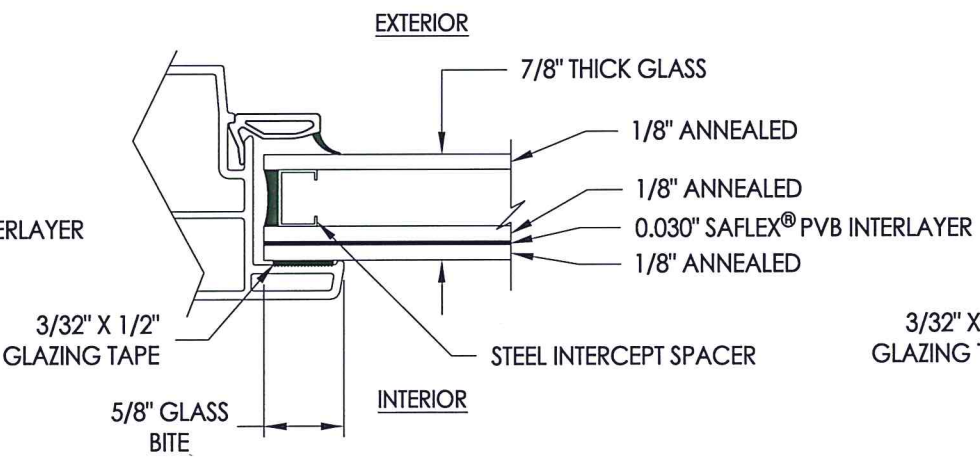

G5 GLAZING DETAIL

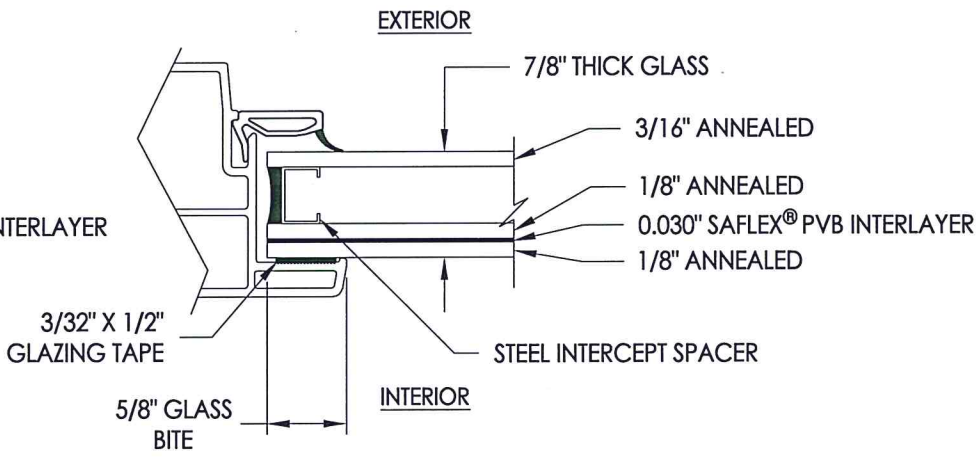

G6 GLAZING DETAIL

PRODUCT:	FIXED WINDOW
PART OR ASSEMBLY:	GLAZING DETAILS

NO.	DATE	BY	REVISIONS

DATE: 7/30/20
SCALE: N.T.S.
DWG. BY: RW
CHK. BY: LFS
DRAWING NO.: TX-5089
SHEET 4 OF 5

