

# MODEL 8100 SYSTEM 1 SINGLE HUNG - NON-IMPACT

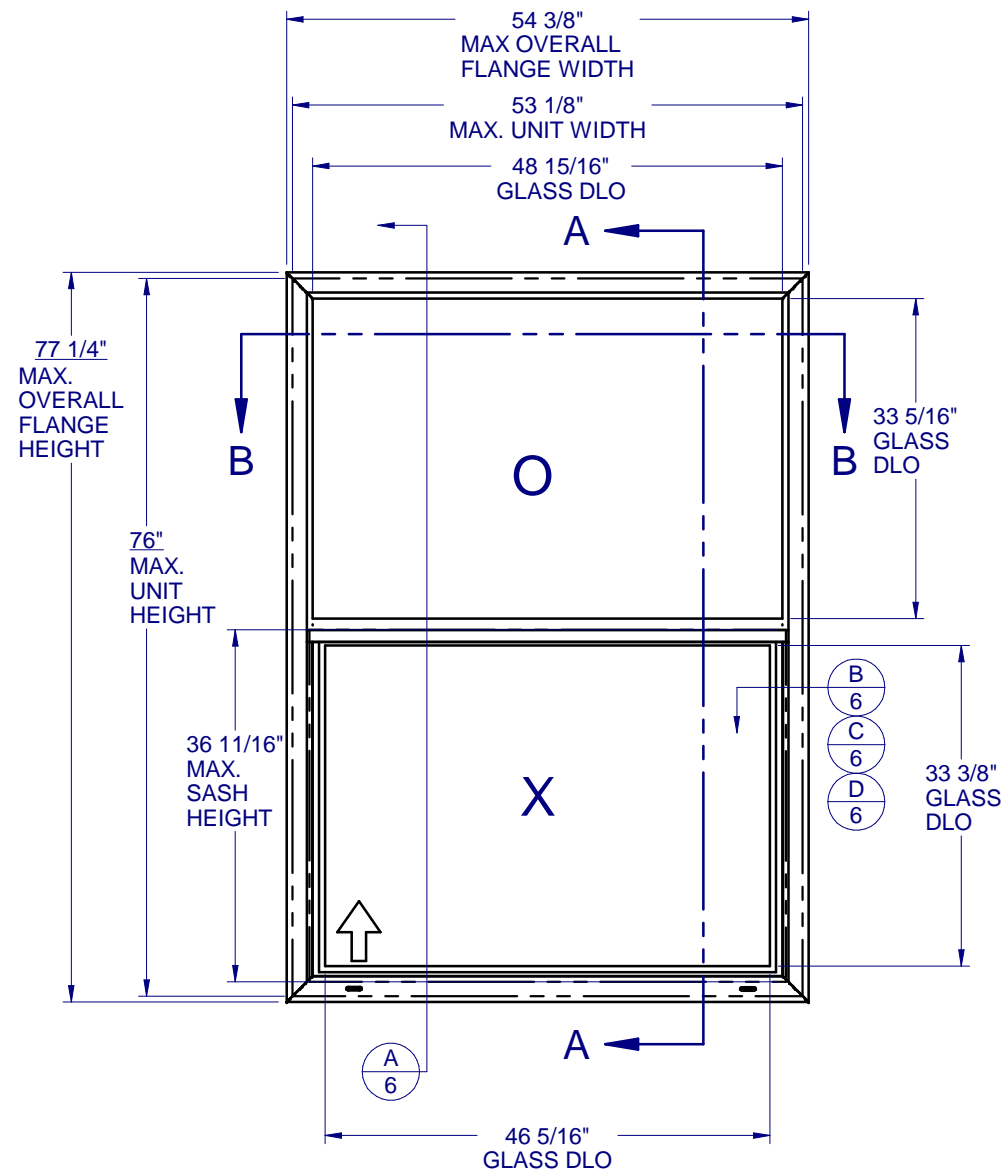

SYSTEM 1 (CAR 138-1007)  
MAXIMUM ALLOWABLE DESIGN PRESSURE: +50/-50 PSF

### TABLE OF CONTENTS

GENERAL NOTES & ELEVATIONS.....	1
DP CHARTS & GLAZING DETAIL.....	2
SECTION VIEWS & ALT. FRAME.....	3
EXTRUSIONS & B.O.M.....	4
ANCHOR SCHEDULE & NOTES.....	5
INSTALLATION DETAILS.....	6

### GENERAL NOTES:

1. THE PRODUCT SHOWN HEREIN IS DESIGNED AND MANUFACTURED TO COMPLY WITH THE REQUIREMENTS OF THE 2018 INTERNATIONAL BUILDING CODE AND 2018 INTERNATIONAL RESIDENTIAL CODE.
2. GLAZING OPTIONS: (SEE SHEET 2)
3. CONFIGURATIONS: "O/X".
4. ANCHORAGE: THE 33 1/3% STRESS INCREASE HAS NOT BEEN USED IN THE DESIGN OF THIS PRODUCT. SEE SHEET 6 FOR ANCHOR DETAILS. WINDLOAD DURATION FACTOR Cd=1.6 WAS USED FOR WOOD ANCHOR CALCULATIONS.
5. NOT APPROVED FOR IMPACT RESISTANCE. IMPACT PROTECTIVE SYSTEM IS REQUIRED IN WIND BORNE DEBRIS REGION.
6. ALL FRAMES AND VENTS FULLY WELDED. SMALL JOINT SEAM SEALANT USED AT FIXED MEETING RAIL AND JAMB.
7. SERIES / MODEL DESIGNATION SH-8100.
8. THE DESIGNATION X AND O STAND FOR THE FOLLOWING:  
X = OPERABLE SASH, O = FIXED SASH
9. SECTION CALLOUTS APPLY TO ALL ELEVATIONS IN A SIMILAR LOCATION.
10. EXTERNAL WEEP SLOT = 1/2" x 2-1/2" LOCATED 4" FROM BOTH ENDS.

**Custom**  
**WINDOW SYSTEMS**

1900 SW 44TH AVE.  
OCALA, FLORIDA 34474  
WWW.CWS.CC

## 8100 PVC SINGLE HUNG NON-IMPACT

NO.:	DESCRIPTION:	BY:	DATE:
C	REVISED TO TDI REQUEST	MS	12/14/21
B	REVISED TO TDI REQUEST	JML	3/8/17
A	REVISED TO TDI REQUEST	JML	8/2/16

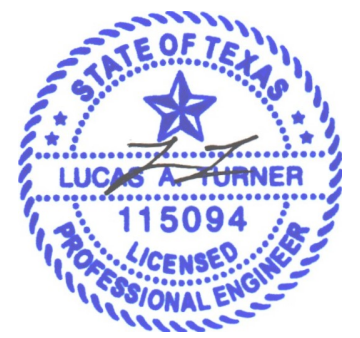

1/14/2021

LUCAS A. TURNER, P.E.  
TX PE # 115094  
2428 OLD NATCHEZ TRC TRL  
CAMDEN, TN 38320  
PH. 941-380-1574

SHEET DESCRIPTION:

### GENERAL NOTES AND ELEVATIONS

DRAWN BY:	DATE:
EMK	11/10/15
DWG #:	REV.:
TDI-154	C
SCALE:	SHEET
1:33.33	1 OF 6





PARTS LIST			
ITEM	PART #	DESCRIPTION	MATERIAL
1	H-6222	Main Fr., SH, w/Flg., PVC, Head	Vinyl
2	H-6222	Main Fr., SH, w/Flg., PVC, Sill	Vinyl
3	H-6222	Main Fr., SH, w/Flg., PVC, L. Jb.	Vinyl
4	H-6222	Main Fr., SH, w/Flg., PVC, R. Jb.	Vinyl
5	H-2121	Meet. Rail, Fxd.	Alum
8	H-6224	Sash Meet. Rail, PVC	Vinyl
9	H-2124	Reinf. Sash Meet. Rail	Alum
10	H-6223	Sash Bottom Rail, PVC	Vinyl
12	H-6225	Sash Side/Top/Bot. Rail	Vinyl
13	S-2129	Reinf. S.B.R./S.S.R	Alum
14	S-6237	Glz. Bd., 7/8", Fxd., Horiz.	Vinyl
15	S-6237	Glz. Bd., 7/8", Fxd., Vert.	Vinyl
16	S-6237	Glz. Bd., 7/8", Sash, Horiz.	Vinyl
17	S-6237	Glz. Bd., 7/8", Sash, Vert.	Vinyl
18	S-6226	Scm. Adapt., w/Nib, PVC, Horiz.	Vinyl
19	S-6227	Scm. Adapt., PVC, Vert.	Vinyl
20	S-6025	Sash Stop / Filler, PVC, Vert.	Vinyl
24		Balance	
25	P-3059	Sash Cam, PVC	Plastic
26	P-3046	Take Out Clip	SS
27	P-3783	Lock, Impact, PVC	
28	P-4069	Keeper, Impact, PVC	Zamac
30	P-4479	Weep Cover w/ Flap	Plastic
32	P-3429	Wstp., 0.270 x .187 back FinSeal, Gray	
33	P-3429	Wstp., 0.270 x .187 back FinSeal, Gray	
34	P-3429	Wstp., 0.270 x .187 back FinSeal, Gray	
35	P-3429	Wstp., 0.270 x .187 back FinSeal, Gray	
36	P-3429	Wstp., 0.270 x .187 back FinSeal, Gray	
37	P-4638	#8 x 2-1/2 PH Mod. Truss Type A, Tek 2	Steel
38	P-3768	#8 x 0.625 Ph PH SMS	Steel
39	P-4051W	#8 x 1.250 Ph FH TEK, Wht.	Steel
40	P-3539	#8 x 3/4 PH PN, TEK, Wht	Steel
44	P-3342	Seam Sealer, SM-5504	
45	P-5588	Cap Plug, 1/2" Hole	Nylon
46	P-3438	Sikaflex 552 or Purfect Glaze "H"	
48	P-5615	Set. Blk., 85 Dur., 1/8" x 1" x 2" Lg.	Rubber
51	P-3881	Temporary Lbl. (NFRC/DP)	
52	P-3613	CWS Lbl. (logo)	
53		Glass, Fixed (See Sheet 3)	
54		Glass, Sash (See Sheet 3)	
55		Spacer (see sheet 3)	
56		Spacer (see sheet 3)	
62	P-3218	Screen Frame, Horiz.	Alum
63	P-3218	Screen Frame, Vert.	Alum
64	P-3321	Screen Frame Corner Key	Plastic
65	P-3581	Screen Cloth, 18 x 16 Fiberglass	Fiberglass
66	P-3228	Screen Spline, .155 Dia., Blk.	Vinyl
67	P-3029	Screen Pull Tab	Alum
68	P-3033	Screen Spring, SS	SS
69	H-6231	Main Fr., SH, w/Fin., PVC	Vinyl
71	S-6228	Fixed Rail Cover	Vinyl

LINE ITEMS NOT USED:  
6-7, 11, 21-23, 29, 31, 41-43, 47, 49-50, 57-61

NOTE: ALL EXTRUSIONS ARE ALUMINUM 6063-T6 UNLESS OTHERWISE NOTED.

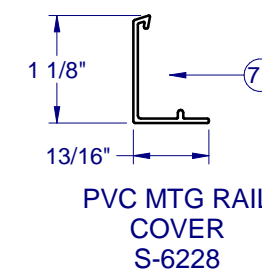
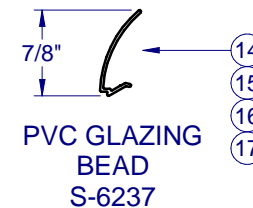
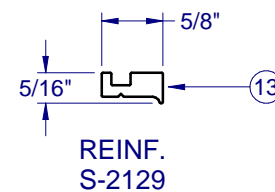
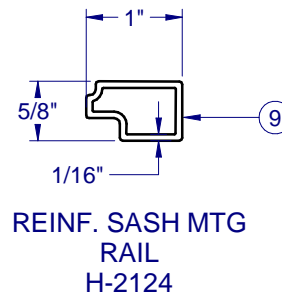
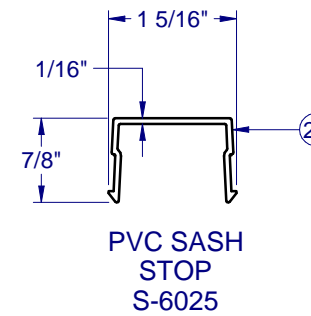
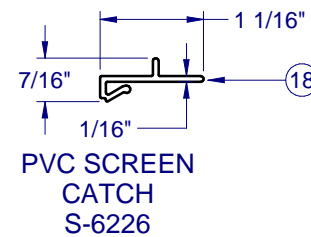
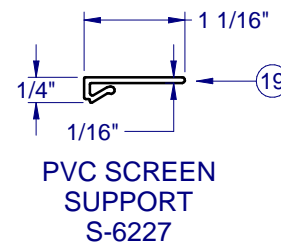
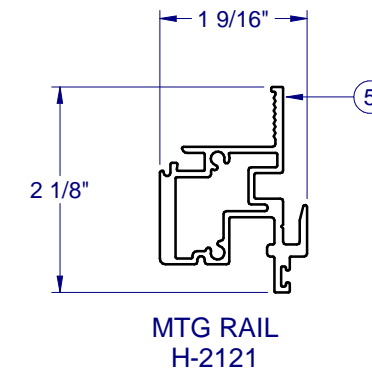
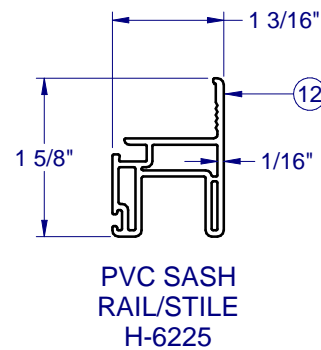
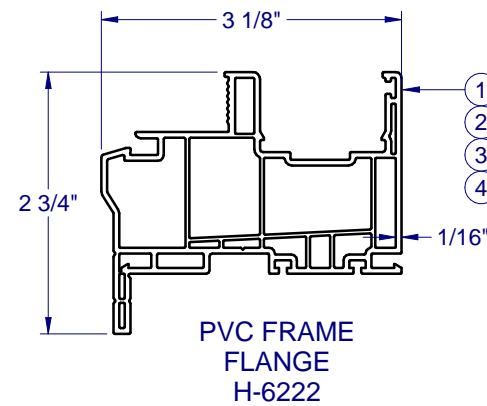
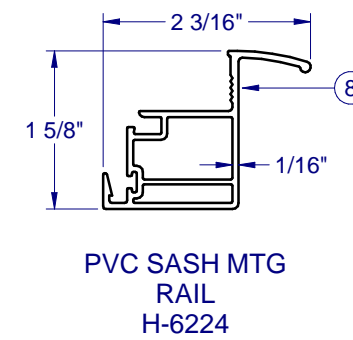
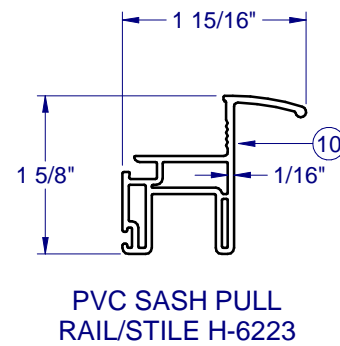
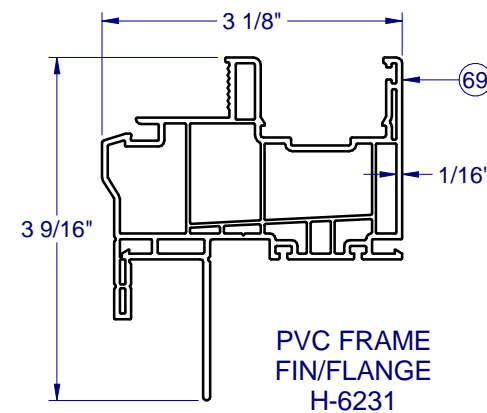

**FRAME CORNER CONSTRUCTION**

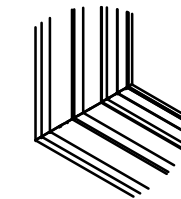

CORNER WELD (ALL SIDES) 1:8

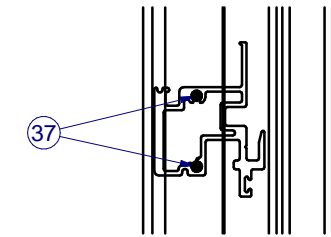

FIXED MEETING RAIL SCREWED TOGETHER WITH OUTERFRAME 1:8



1900 SW 44TH AVE.  
OCALA, FLORIDA 34474  
WWW.CWS.CC

**8100 PVC SINGLE HUNG NON-IMPACT**

NO.	DESCRIPTION:	BY:	DATE:
C	REVISED TO TDI REQUEST	MS	12/14/21
B	REVISED TO TDI REQUEST	JML	3/8/17
A	REVISED TO TDI REQUEST	JML	8/2/16

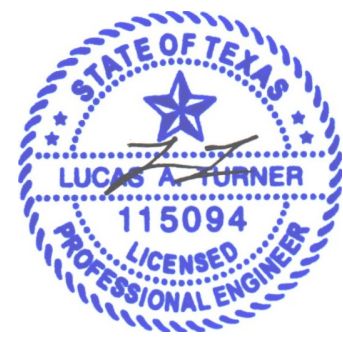

1/14/2021

LUCAS A. TURNER, P.E.  
TX PE # 115094  
2428 OLD NATCHEZ TRC TRL  
CAMDEN, TN 38320  
PH. 941-380-1574

SHEET DESCRIPTION:

**BOM AND EXTRUSIONS**

DRAWN BY: <b>EMK</b>	DATE: <b>11/10/15</b>
DWG #: <b>TDI-154</b>	REV.: <b>C</b>
SCALE: <b>1:8</b>	SHEET <b>4 OF 6</b>

**8100 PVC  
SINGLE HUNG  
NON-IMPACT**

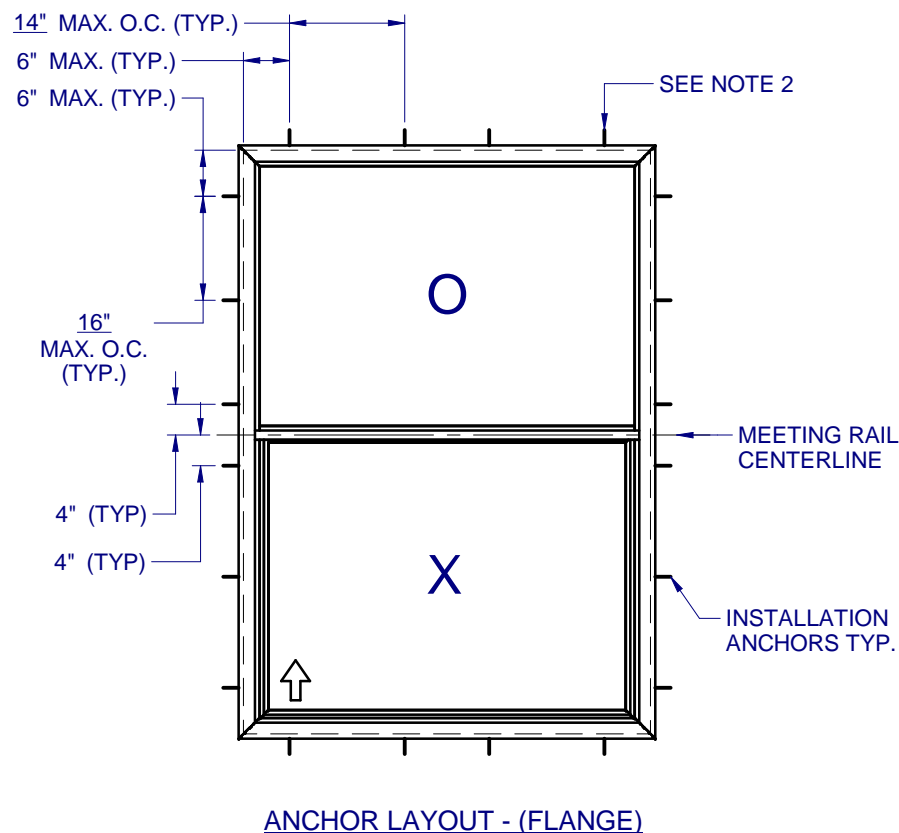

ANCHOR LAYOUT - (FLANGE)

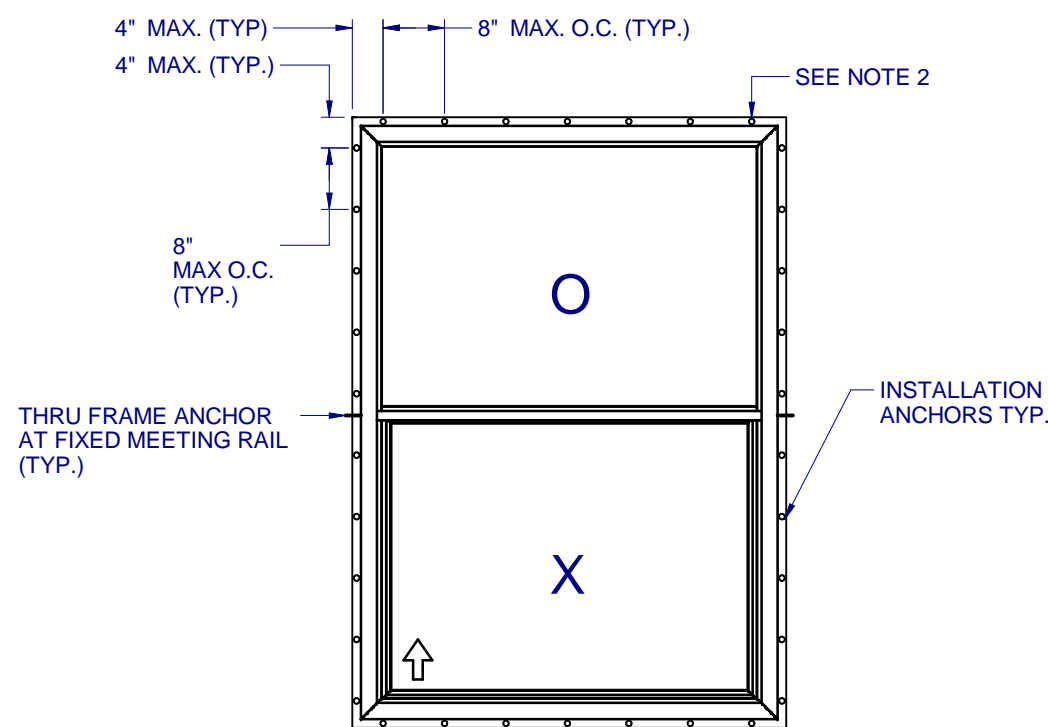

ANCHOR LAYOUT - (FIN)

NOTES:

1. INSTALL ONE ANCHOR AT EACH INSTALLATION LOCATION. SILL ANCHOR SPACING SAME AS HEAD.
2. SHIM AS REQ AT EACH INSTALLATION ANCHOR USING LOAD BEARING SHIMS. MAX. ALLOWABLE SHIM STACK TO BE 1/4". USE SHIMS WHERE SPACE GREATER THAN 1/16" IS PRESENT. LOAD BEARING SHIMS SHALL BE CONSTRUCTED OF HIGH DENSITY PLASTIC OR BETTER. WOOD SHIMS ARE NOT ALLOWED.
3. ANCHOR TYPE, SIZE, SPACING AND EMBEDMENT SHALL BE AS SPECIFIED IN THESE DRAWINGS, SEE TABLE 1, SHEET 6.
4. ALL INSTALLATION ANCHORS MUST BE MADE OF OR PROTECTED WITH A CORROSION RESISTANT MATERIAL OR COATING. DISSIMILAR METALS OR MATERIALS IN CONTACT WITH PRESSURE TREATED WOOD MUST BE PROTECTED TO PREVENT REACTION.
5. INSTALLATION ANCHORS SHALL BE IN ACCORDANCE WITH ANCHOR MANUFACTURER'S INSTALLATION INSTRUCTIONS, AND ANCHORS SHALL NOT BE USED IN SUBSTRATES WITH STRENGTHS LESS THAN THE MINIMUM SPECIFIED IN TABLE 1, SHEET 6.
6. ANCHOR EMBEDMENT TO SUBSTRATE SHALL BE BEYOND WALL DRESSING OR STUCCO. FOR CONCRETE/CMU OPENINGS, EMBEDMENT SHALL BE BEYOND WOOD BUCKS, IF USED, INTO SUBSTRATE - 1X BUCKS ARE OPTIONAL.
7. A MINIMUM CENTER-TO-CENTER SPACING SHALL BE MAINTAINED BETWEEN ALL FASTENERS: 3" FOR MASONRY, 1" FOR WOOD AND METAL.
8. WOOD OR MASONRY OPENINGS, BUCKS AND BUCK FASTENERS SHALL BE PROPERLY DESIGNED BY THE ARCHITECT OR ENGINEER OF RECORD AND INSTALLED TO TRANSFER WIND LOADS TO THE STRUCTURE. SUBSTRATES SHALL MEET THE MINIMUM STRENGTH REQUIREMENTS AS SHOWN IN TABLE1, SHEET 6. CONCRETE AND MASONRY SUBSTRATES MAY NOT BE CRACKED.
9. SEALING AND FLASHING STRATEGIES FOR OVERALL WATER RESISTANCE OF INSTALLATION SHALL BE DONE BY OTHERS FOLLOWING THE CURRENT VERSION OF THE REFERENCE DOCUMENTS: FMA/AAMA 100(FIN WINDOWS), FMA/AAMA 200(FLANGE WINDOWS), FMA/WDMA 250(BOX WINDOWS), FMA/AAMA/WDMA 300(EXTERIOR DOORS)

NO.:		DESCRIPTION:	BY:	DATE:
C	REVISOR	REVISOR	MS	12/14/21
B	REVISOR	REVISOR	JML	3/8/17
A	REVISOR	REVISOR	JML	8/2/16



1/14/2021

LUCAS A. TURNER, P.E.  
TX PE # 115094  
2428 OLD NATCHEZ TRC TRL  
CAMDEN, TN 38320  
PH. 941-380-1574

SHEET DESCRIPTION:  
**ANCHOR SCHEDULE AND NOTES**

DRAWN BY:	DATE:
EMK	11/10/15
DWG #:	REV.:
TDI-154	C
SCALE:	SHEET
1:25	5 OF 6



**8100 PVC  
SINGLE HUNG  
NON-IMPACT**

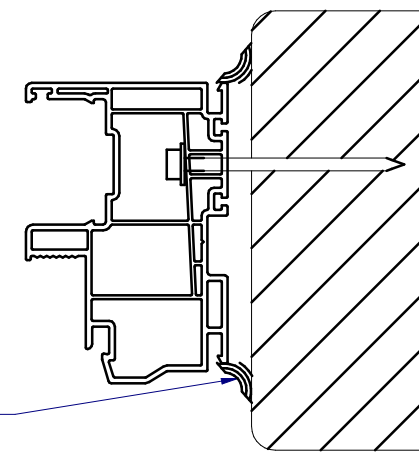
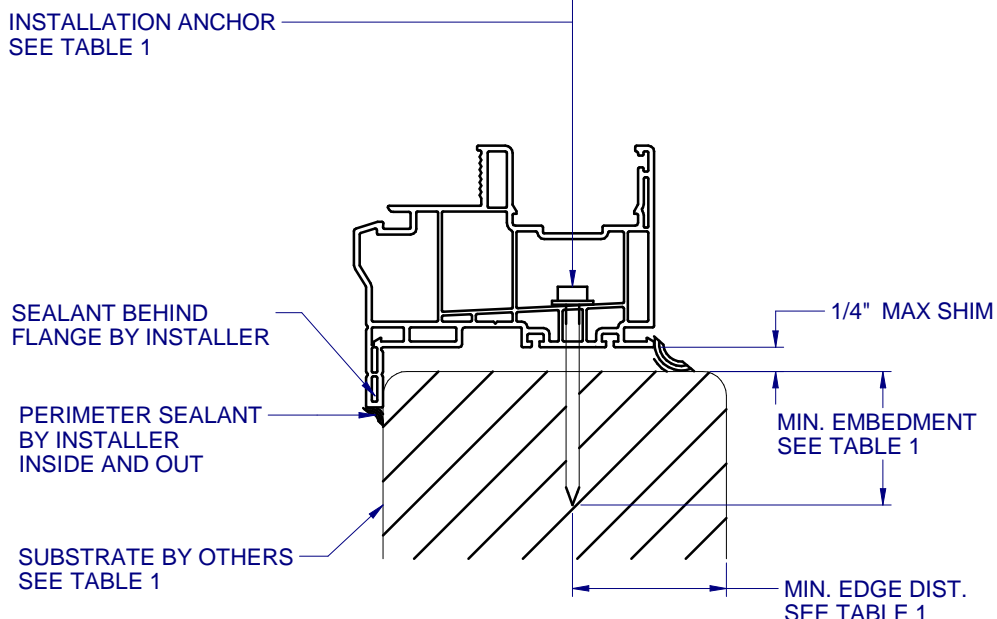
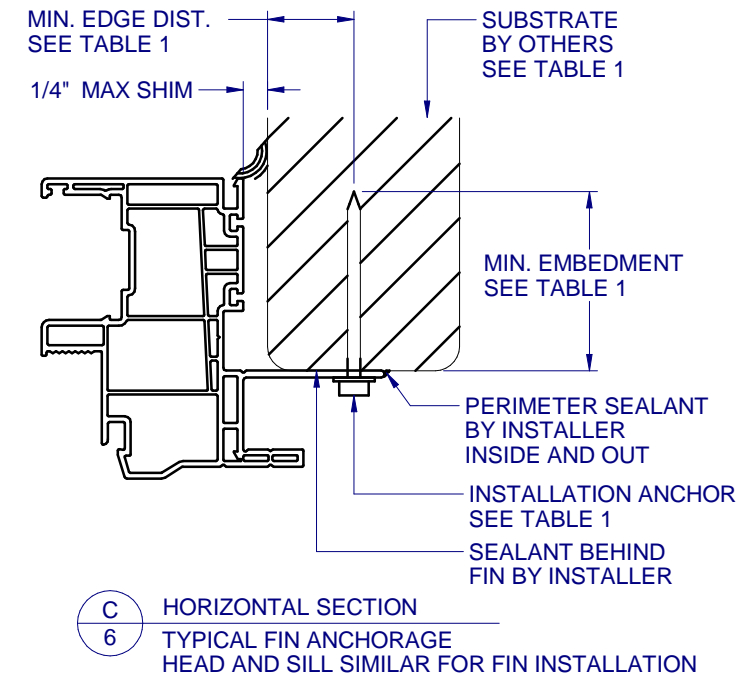
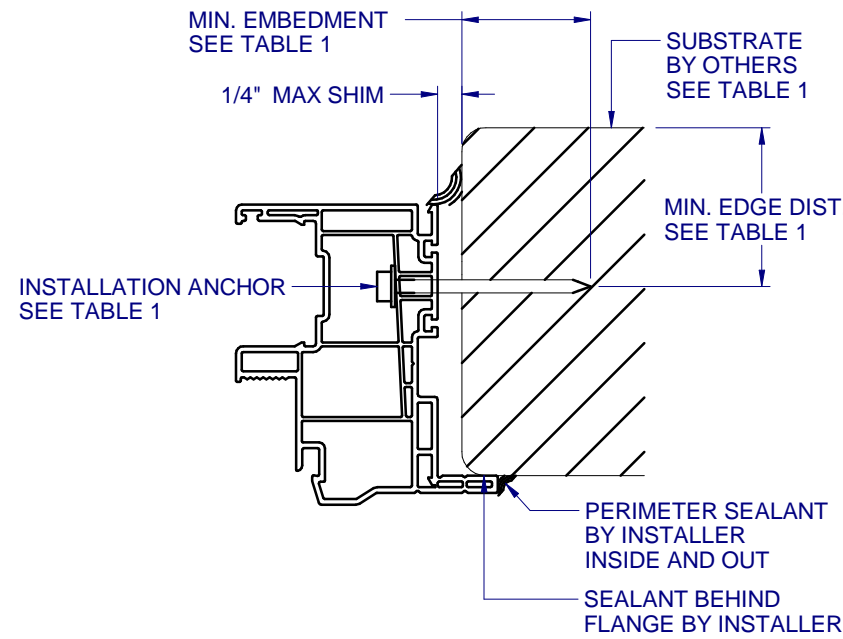
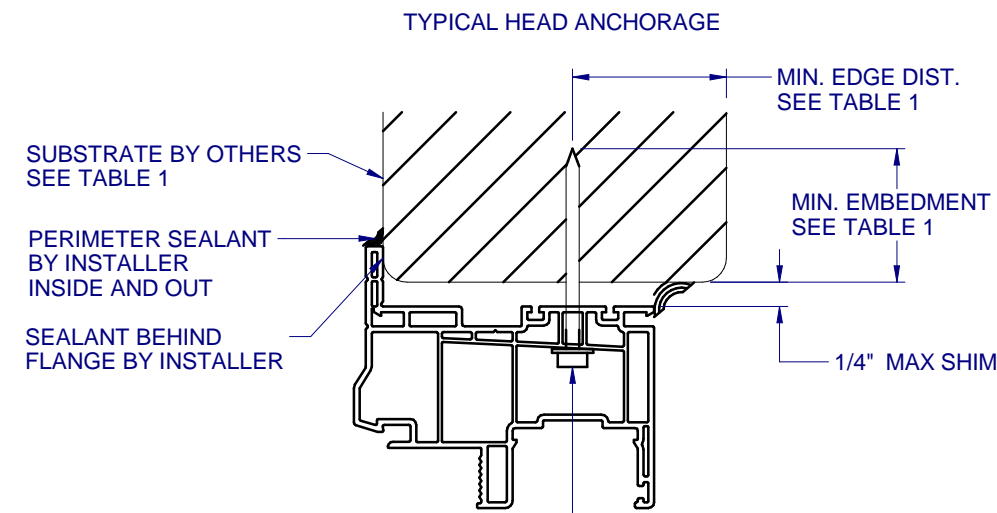

TABLE 1: APPROVED INSTALLATION FASTENERS				
FRAME TYPE	SUBSTRATE TYPE	ANCHOR TYPE	MIN. EMBEDMENT	MIN. EDGE DIST.
FLANGE	CONCRETE (2.0 KSI MIN.)	3/16" ITW TAPCON	1"	1-1/8"
FLANGE	HOLLOW OR GROUT-FILLED CMU (117 PCF MIN.)	3/16" ITW TAPCON	1"	2"
FLANGE	CONCRETE (2.85 KSI MIN.)	3/16" ELCO ULTRACON	1"	1"
FLANGE	GROUT-FILLED CMU (ASTM C-90)	3/16" ELCO ULTRACON	1-1/4"	2-1/2"
FLANGE	2X MIN. SOUTHERN PINE (G=0.55)	3/16" ITW TAPCON OR ELCO ULTRACON	1-3/8"	7/8"
FLANGE	2X MIN. SOUTHERN PINE (G=0.55)	#10 SHEET METAL SCREW W/ WASHER COMBO	2"	7/8"
FLANGE	16 GAUGE (0.060") MIN. STEEL STUD (33 KSI YIELD MIN)	#10-16 HILTI KWIK-FLEX OR ITW TEKS SELF-DRILLING SCREW	FULL THREAD THRU 0.060"	7/16"
FLANGE	1/8" ALUM. (6063-T5 MIN.) OR 1/8" STEEL (33 KSI MIN.)	#10 GRADE 5 SELF-TAPPING / DRILLING SCREW	FULL THREAD THRU 0.125"	7/16"
FIN	2X MIN. SOUTHERN PINE (G=0.55)	#10 SHEET METAL SCREW W/ WASHER COMBO	2"	1/2"

FLANGE REMOVAL NOTE: PARTIALLY OR FULLY REMOVING THE FLANGE, UP TO AND INCLUDING A BOX-FRAME APPLICATION IS ACCEPTABLE PROVIDED:

- MIN. 1/4" FILLET OF CONSTRUCTION-GRADE ADHESIVE CAULK IS APPLIED INSIDE AND OUT, FULL PERIMETER, BY INSTALLER.
- PRODUCT ANCHORAGE IS IN ACCORDANCE WITH REQUIREMENTS AS SHOWN FOR FLANGE WINDOWS.

NO.	DESCRIPTION:	BY:	DATE:
C	REVISED TO TDI REQUEST	JML	12/14/21
B	REVISED TO TDI REQUEST	JML	3/8/17
A	REVISED TO TDI REQUEST	JML	8/2/16

REVISIONS



1/14/2021

LUCAS A. TURNER, P.E.  
TX PE # 115094  
2428 OLD NATCHEZ TRC TRL  
CAMDEN, TN 38320  
PH. 941-380-1574

SHEET DESCRIPTION:

**INSTALLATION DETAILS**

DRAWN BY: EMK	DATE: 11/10/15
DWG #: TDI-154	REV.: C
SCALE: 1:2	SHEET 6 OF 6