

MODEL 8200 SYSTEM 1 HORIZONTAL SLIDER - NON-IMPACT

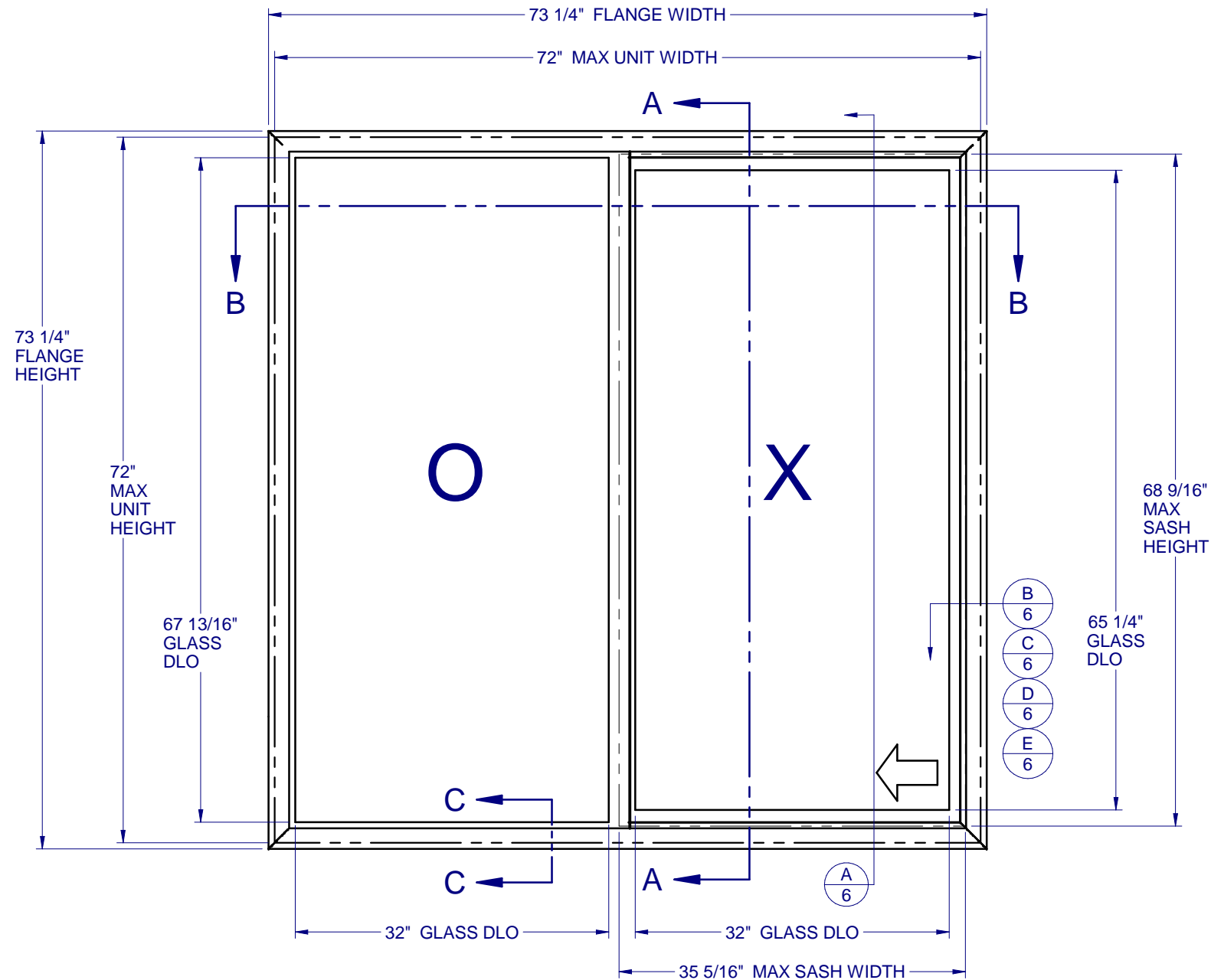

SYSTEM 1 (CAR 138-1069)
MAXIMUM ALLOWABLE DESIGN PRESSURE: +40/-40 PSF

TABLE OF CONTENTS

GENERAL NOTES & ELEVATIONS.....	1
DP CHART & GLAZING DETAILS.....	2
SECTION VIEWS & ALT. FRAME.....	3
EXTRUSIONS & B.O.M.....	4
ANCHOR SCHEDULE & NOTES.....	5
INSTALLATION DETAILS.....	6

GENERAL NOTES:

1. THE PRODUCT SHOWN HEREIN IS DESIGNED AND MANUFACTURED TO COMPLY WITH THE REQUIREMENTS OF THE 2018 INTERNATIONAL BUILDING CODE (IBC) AND 2018 INTERNATIONAL RESIDENTIAL CODE (IRC).
2. GLAZING OPTIONS: (SEE SHEET 2)
3. CONFIGURATIONS: "OX", "XO".
4. ANCHORAGE: THE 33 1/3% STRESS INCREASE HAS NOT BEEN USED IN THE DESIGN OF THIS PRODUCT. SEE SHEET 6 FOR ANCHOR DETAILS. WINDLOAD DURATION FACTOR Cd=1.6 WAS USED FOR WOOD ANCHOR CALCULATIONS.
5. NOT APPROVED FOR IMPACT RESISTANCE. IMPACT PROTECTIVE SYSTEM IS REQUIRED IN WIND BORNE DEBRIS REGION.
6. ALL FRAMES AND VENTS FULLY WELDED. SMALL JOINT SEAM SEALANT USED AT FIXED MEETING RAIL AND JAMB.
7. SERIES / MODEL DESIGNATION HS-8200.
8. THE DESIGNATION X AND O STAND FOR THE FOLLOWING:
X = OPERABLE SASH, O = FIXED SASH
9. SECTION CALLOUTS APPLY TO ALL ELEVATIONS IN A SIMILAR LOCATION.
10. EXTERNAL WEEP SLOT = 1/4" x 1" LOCATED 4" FROM BOTH ENDS.



1900 SW 44TH AVE.
OCALA, FLORIDA 34474
WWW.CWS.CC

8200 PVC HORZ. SLIDER NON-IMPACT

NO.	DESCRIPTION:	BY:	DATE:
D	REVISED TO TDI REQUEST	MS	03/24/22
C	IBC/RC REF. 2018 UPDATE	JLD	4/10/20
B	REVISED TO TDI REQUEST	JML	3/21/17
A	REVISED TO TDI REQUEST	JML	8/2/16



4/1/2022

LUCAS A. TURNER, P.E.
TX PE # 115094
2428 OLD NATCHEZ TRC TRL
CAMDEN, TN 38320
PH. 941-380-1574

SHEET DESCRIPTION:
GENERAL NOTES AND ELEVATIONS

DRAWN BY: EMK	DATE: 11/11/2015
DWG #: TDI-223	REV.: D
SCALE: 1:14.29	SHEET 1 OF 6

**8200 PVC
HORZ. SLIDER
NON-IMPACT**

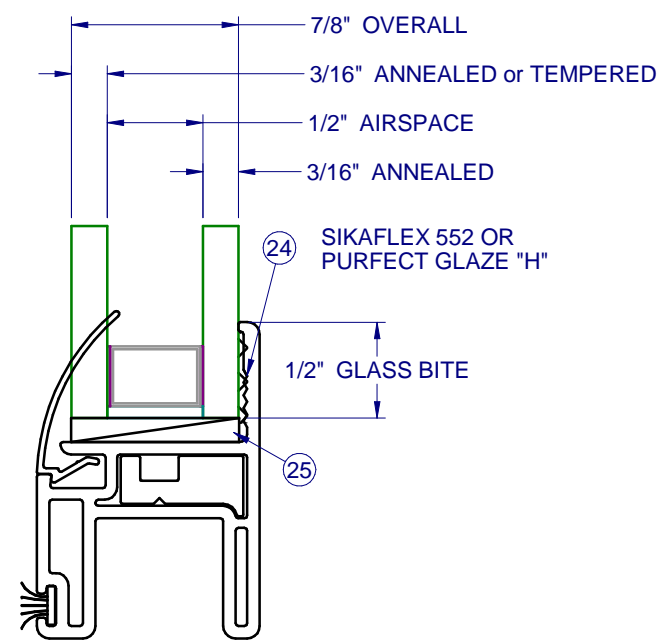
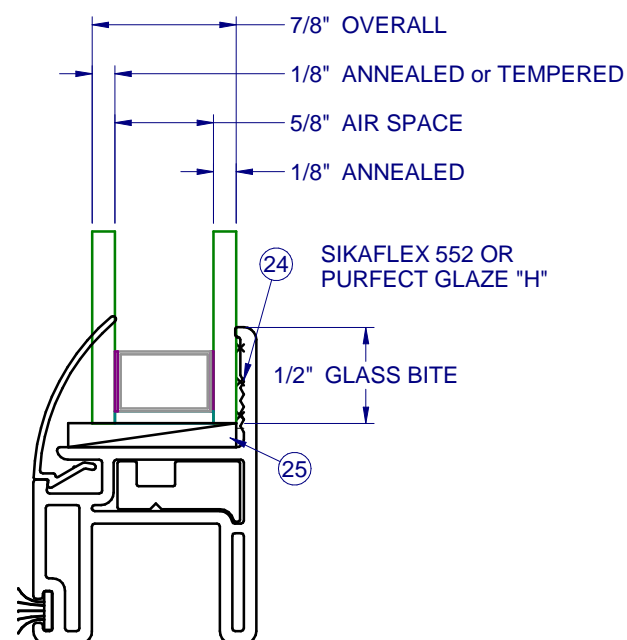

NO.:	DESCRIPTION:	BY:	DATE:
D	REVISED TO TDI REQUEST	MS	03/24/22
C	IBC/RC REF. 2018 UPDATE	JLD	4/10/20
B	REVISED TO TDI REQUEST	JML	3/21/17
A	REVISED TO TDI REQUEST	JML	8/2/16



4/1/2022

LUCAS A. TURNER, P.E.
TX PE # 115094
2428 OLD NATCHEZ TRC TRL
CAMDEN, TN 38320
PH. 941-380-1574

SHEET DESCRIPTION:
GLAZING DETAILS

DRAWN BY: EMK	DATE: 11/11/2015
DWG #: TDI-223	REV.: D
SCALE: 1:1	SHEET 2 OF 6

REVISIONS

**8200 PVC
HORZ. SLIDER
NON-IMPACT**

NO.:	DESCRIPTION:	BY:	DATE:
D	REVISED TO TDI REQUEST	MS	03/24/22
C	IBC/RC REF. 2018 UPDATE	JLD	4/10/20
B	REVISED TO TDI REQUEST	JML	3/21/17
A	REVISED TO TDI REQUEST	JML	8/2/16



4/1/2022

LUCAS A. TURNER, P.E.
TX PE # 115094
2428 OLD NATCHEZ TRC TRL
CAMDEN, TN 38320
PH. 941-380-1574

SHEET DESCRIPTION:

DRAWN BY: EMK	DATE: 11/11/2015
DWG #: TDI-223	REV.: D
SCALE: 1:2	SHEET 3 OF 6

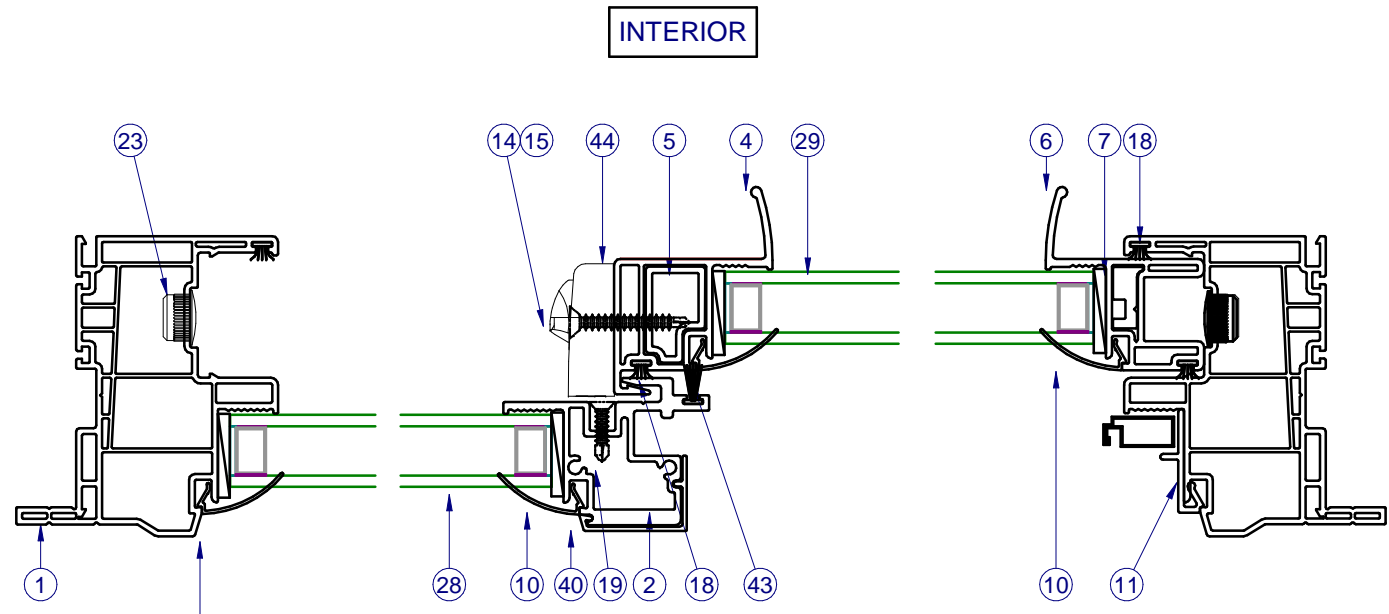

SECTION VIEW B-B

NOTE: FIXED LITE AT HEAD
AND SILL IS SIMILAR.

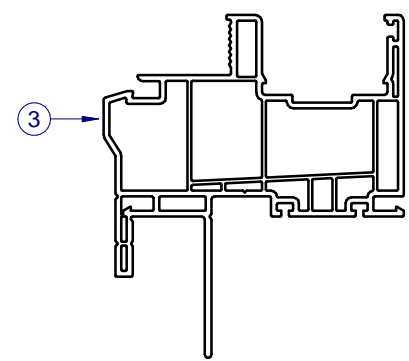

SECTION C-C
ALT. FIN/FLANGE FRAME

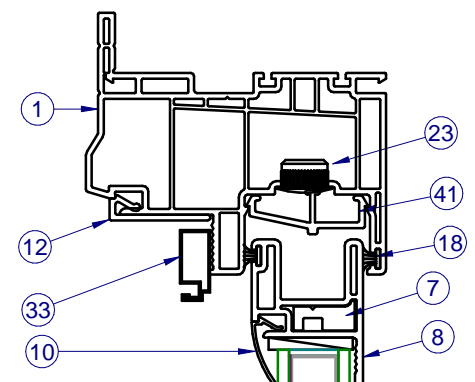

SECTION VIEW A-A

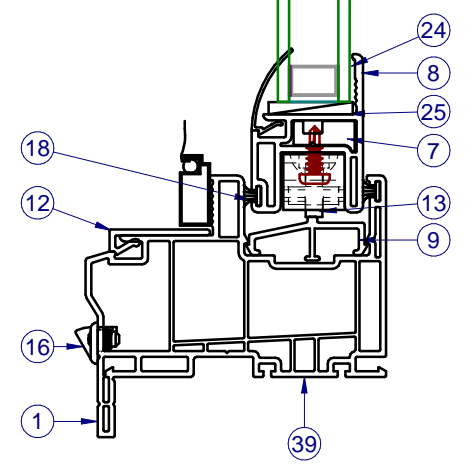

INTERIOR

NOTE: ITEMS NOT SHOWN FOR CLARITY:
22, 30-31

PARTS LIST

ITEM	PART #	DESCRIPTION	MATERIAL
1	H-6222	Main Fr., SH, w/Flg., PVC	PVC
2	H-2121	Meet. Rail, Fxd.	Alum
3	H-6231	Main Fr., SH, w/Fin., PVC	PVC
4	H-6224	Sash Meet. Rail, PVC	PVC
5	H-2124	Reinf. Sash Meet. Rail	Alum
6	H-6223	Sash Bottom Rail, PVC (S.S.R. for HS)	PVC
7	S-2129	Reinf. S.B.R./S.S.R/S.T.R.	Alum
8	H-6225	Sash Top/Bot. Rail	PVC
9	S-1776	Roller track	Alum
10	S-6237	Glz. Bd., 7/8", Fxd., Horiz.	PVC
11	S-6226	Scrn. Adapt., w/ Nib, PVC	PVC
12	S-6227	Scrn. Adapt., PVC	PVC
13	P-4779	Roller, Tandem	Nylon
14	P-3783	Lock, Impact, PVC	Zinc
15	P-4069	Keeper, Impact, PVC	Zinc
16	P-4479	Weep Cover w/ Flap	Nylon
18	P-3429	Wstp., 0.270 x .187 back FinSeal, Gray	
19	P-3539	#8 x 0.75" Ph PH Tek@keeper	Steel
20	P-3541	#8 x 0.5 Ph PH Tek@roller	Steel
21	P-4051W	#8 x 1.250 Ph FH TEK, Wht.@lock	Steel
22	P-3342	Seam Sealer, SM-5504	Silicone
23	P-5588	Cap Plug, 1/2" Hole	Nylon
24	P-4648	Purfect Glaze "H", Sika Flex 552	Silicone
25	P-5615	Set. Blk., 85 Dur., 1/8" x 1" x 2" Lg.	Rubber
26	P-3683	HS-8200 Gold Cert. Label	
27	P-3881	Temporary Lbl. (NFRC/DP)	
28	Fixed	SEE SHEET 2	
29	Sash	SEE SHEET 2	
30		Spacer, See SHT 2	
33	P-3218	Screen Frame, Horz.	RollForm
34	P-3321	Screen Frame Corner Key	Nylon
35	P-3581	Screen Cloth, 18 x 16 Fiberglass	
36	P-3228	Screen Spline, .155 Dia., Blk.	
37	P-3029	Screen Pull Tab	
38	P-3033	Screen Spring, SS	
40	S-6228	Fixed rail Cover	PVC
42	P-4638	#8 x 2 1/2", PH, Modified Truss, TEK2	Steel
43	P-4959	Wstp., 0.420 x .187 back FinSeal, Gray	

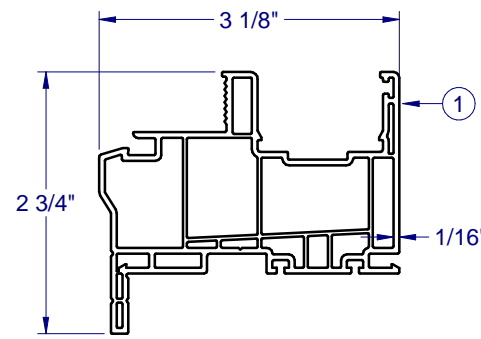

PVC FRAME FLANGE
H-6222

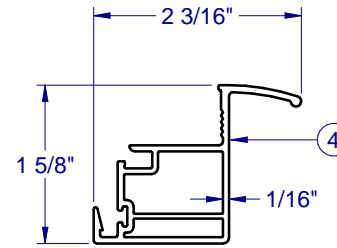

PVC SASH MTG RAIL
H-6224

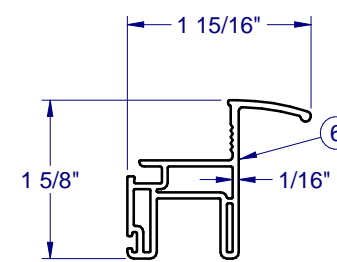

PVC SASH PULL
RAIL/STILE
H-6223

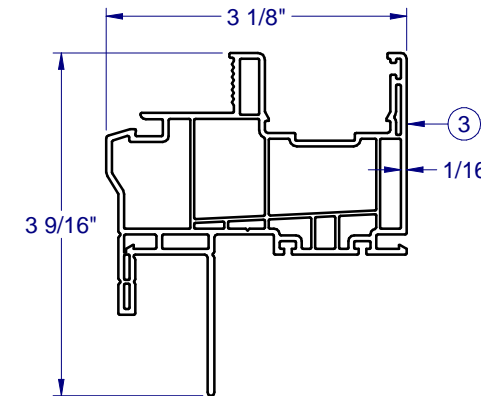

PVC FRAME FIN/FLANGE
H-6231

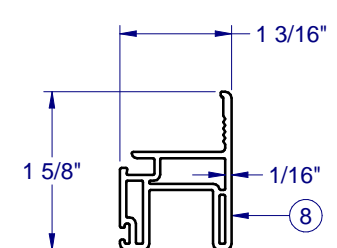

PVC SASH RAIL/STILE
H-6225

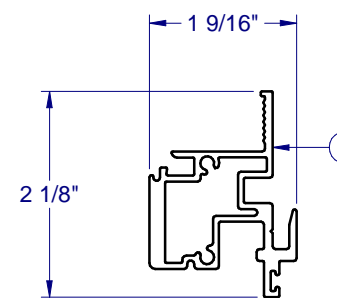

MTG RAIL
H-2121

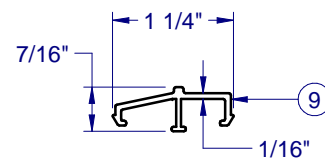

ROLLER TRACK
S-1776

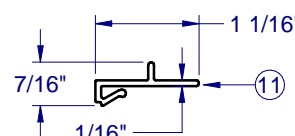

PVC SCREEN CATCH
S-6226

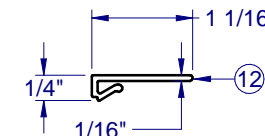

PVC SCREEN SUPPORT
S-6227

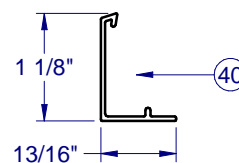

PVC MTG RAIL COVER
S-6228

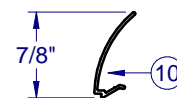

PVC GLAZING BEAD
S-6237

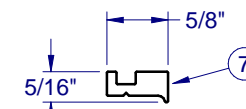

REINF. SBR/SSR
S-2129

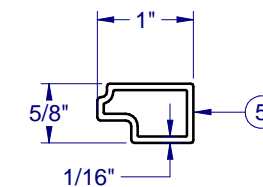

REINF. SASH MTG RAIL
H-2124

CORNER CONSTRUCTION

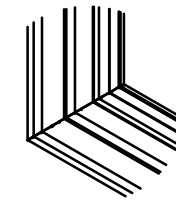

CORNER WELD
(ALL SIDES)
1:8

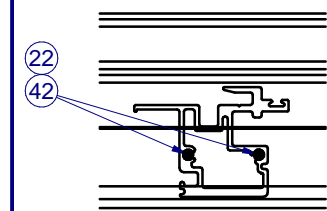

FIXED MEETING RAIL
SCREWED TOGETHER WITH
OUTERFRAME
1:8



1900 SW 44TH AVE.
OCALA, FLORIDA 34474
WWW.CWS.CC

**8200 PVC
HORZ. SLIDER
NON-IMPACT**

NO.	DESCRIPTION:	BY:	DATE:
D	REVISED TO TDI REQUEST	MS	03/24/22
C	IBC/RC REF. 2018 UPDATE	JLD	4/10/20
B	REVISED TO TDI REQUEST	JML	3/21/17
A	REVISED TO TDI REQUEST	JML	8/2/16



4/1/2022

LUCAS A. TURNER, P.E.
TX PE # 115094
2428 OLD NATCHEZ TRC TRL
CAMDEN, TN 38320
PH. 941-380-1574

SHEET DESCRIPTION:
BOM AND EXTRUSIONS

DRAWN BY: EMK	DATE: 11/11/2015
DWG #: TDI-223	REV.: D
SCALE: 1:2	SHEET 4 OF 6

LINE ITEMS NOT USED:
17, 31-32

NOTE: ALL ALUMINUM EXTRUSIONS ARE 6063-T6 UNLESS OTHERWISE NOTED.

**8200 PVC
HORZ. SLIDER
NON-IMPACT**

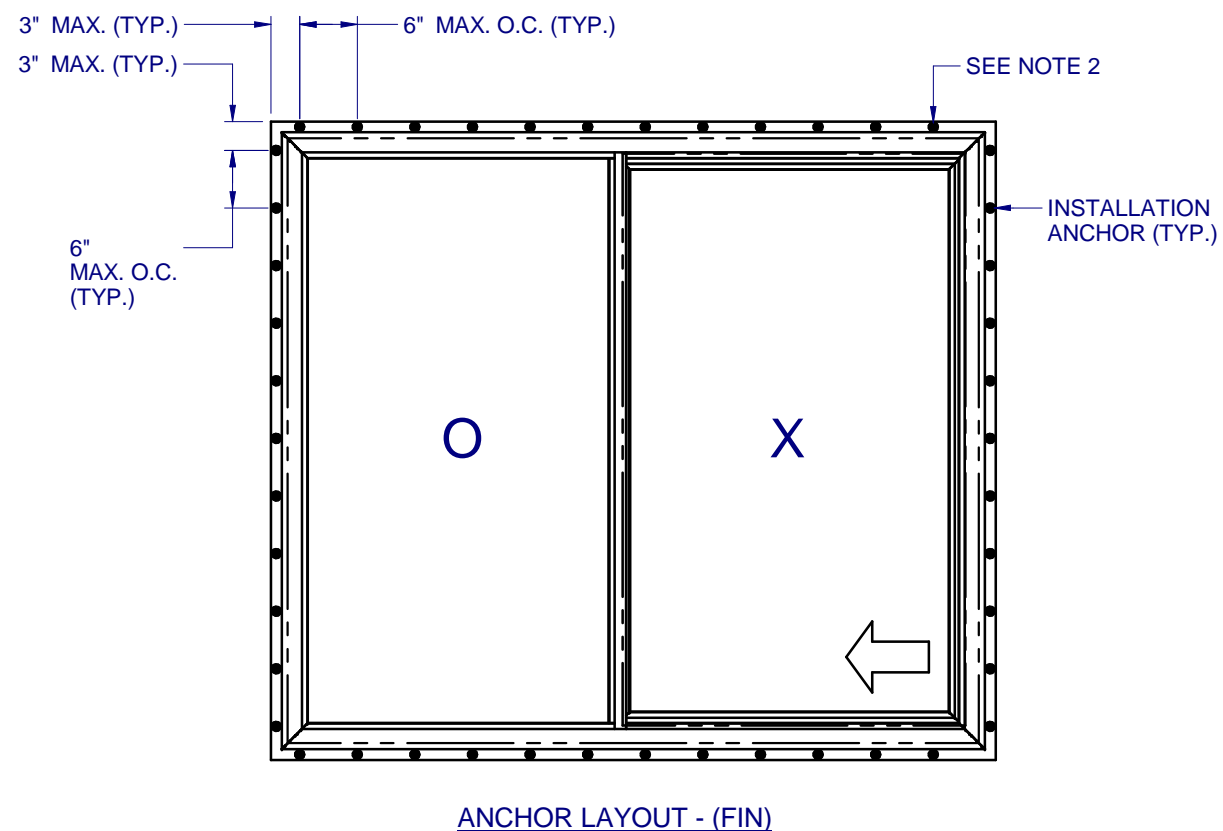
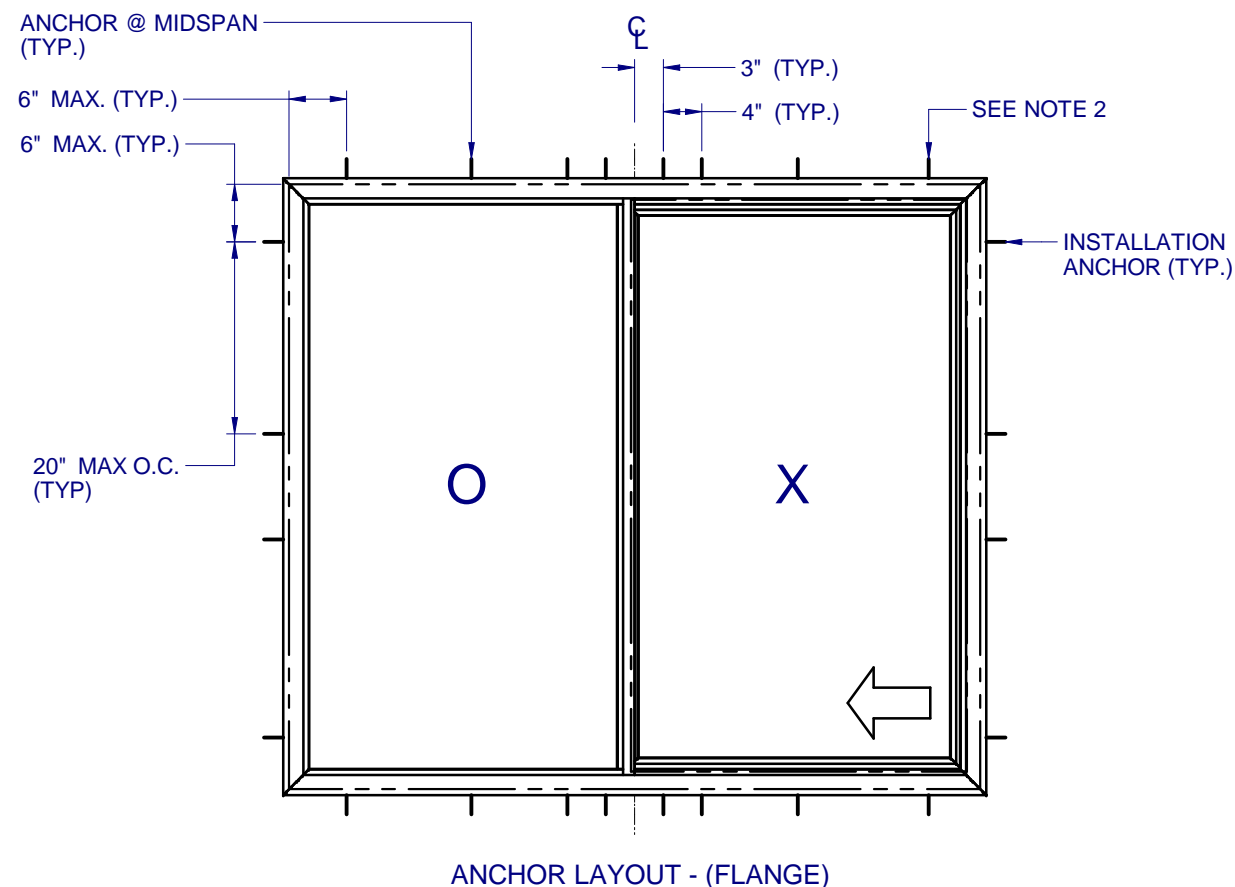

NOTES:

1. INSTALL ONE ANCHOR AT EACH INSTALLATION LOCATION. SILL ANCHOR SPACING SAME AS HEAD.
2. SHIM AS REQ AT EACH INSTALLATION ANCHOR USING LOAD BEARING SHIMS. MAX. ALLOWABLE SHIM STACK TO BE 1/4". USE SHIMS WHERE SPACE GREATER THAN 1/16" IS PRESENT. LOAD BEARING SHIMS SHALL BE CONSTRUCTED OF HIGH DENSITY PLASTIC OR BETTER. WOOD SHIMS ARE NOT ALLOWED.
3. ANCHOR TYPE, SIZE, SPACING AND EMBEDMENT SHALL BE AS SPECIFIED IN THESE DRAWINGS, SEE TABLE 1, SHEET 6.
4. ALL INSTALLATION ANCHORS MUST BE MADE OF OR PROTECTED WITH A CORROSION RESISTANT MATERIAL OR COATING. DISSIMILAR METALS OR MATERIALS IN CONTACT WITH PRESSURE TREATED WOOD MUST BE PROTECTED TO PREVENT REACTION.
5. INSTALLATION ANCHORS SHALL BE IN ACCORDANCE WITH ANCHOR MANUFACTURER'S INSTALLATION INSTRUCTIONS, AND ANCHORS SHALL NOT BE USED IN SUBSTRATES WITH STRENGTHS LESS THAN THE MINIMUM SPECIFIED IN TABLE 1, SHEET 6.
6. ANCHOR EMBEDMENT TO SUBSTRATE SHALL BE BEYOND WALL DRESSING OR STUCCO. FOR CONCRETE/CMU OPENINGS, EMBEDMENT SHALL BE BEYOND WOOD BUCKS, IF USED, INTO SUBSTRATE - 1X BUCKS ARE OPTIONAL.
7. A MINIMUM CENTER-TO-CENTER SPACING SHALL BE MAINTAINED BETWEEN ALL FASTENERS: 3" FOR MASONRY, 1" FOR WOOD AND METAL.
8. WOOD OR MASONRY OPENINGS, BUCKS AND BUCK FASTENERS SHALL BE PROPERLY DESIGNED BY THE ARCHITECT OR ENGINEER OF RECORD AND INSTALLED TO TRANSFER WIND LOADS TO THE STRUCTURE. SUBSTRATES SHALL MEET THE MINIMUM STRENGTH REQUIREMENTS AS SHOWN IN TABLE 1, SHEET 6. CONCRETE AND MASONRY SUBSTRATES MAY NOT BE CRACKED.
9. SEALING AND FLASHING STRATEGIES FOR OVERALL WATER RESISTANCE OF INSTALLATION SHALL BE DONE BY OTHERS FOLLOWING THE CURRENT VERSION OF THE REFERENCE DOCUMENTS: FMA/AAMA 100(FIN WINDOWS), FMA/AAMA 200(FLANGE WINDOWS), FMA/WDMA 250(BOX WINDOWS), FMA/AAMA/WDMA 300(EXTERIOR DOORS)

NO.	DESCRIPTION:	BY:	DATE:
D	REVISED TO TDI REQUEST	MS	03/24/22
C	IBC/IRC REF. 2018 UPDATE	JLD	4/10/20
B	REVISED TO TDI REQUEST	JML	3/21/17
A	REVISED TO TDI REQUEST	JML	8/2/16



4/1/2022

LUCAS A. TURNER, P.E.
TX PE # 115094
2428 OLD NATCHEZ TRC TRL
CAMDEN, TN 38320
PH. 941-380-1574

SHEET DESCRIPTION:
ANCHOR SCHEDULE AND NOTES

DRAWN BY: EMK	DATE: 11/11/2015
DWG #: TDI-223	REV.: D
SCALE: 1:20	SHEET 5 OF 6

**8200 PVC
HORZ. SLIDER
NON-IMPACT**

NO.:	DESCRIPTION:	BY:	DATE:
D	REVISED TO TDI REQUEST	MS	03/24/22
C	IBC/RC REF. 2018 UPDATE	JLD	4/10/20
B	REVISED TO TDI REQUEST	JML	3/21/17
A	REVISED TO TDI REQUEST	JML	8/2/16

REVISIONS



4/1/2022

LUCAS A. TURNER, P.E.
TX PE # 115094
2428 OLD NATCHEZ TRC TRL
CAMDEN, TN 38320
PH. 941-380-1574

SHEET DESCRIPTION:

INSTALLATION DETAILS

DRAWN BY:	DATE:
EMK	11/11/2015
DWG #:	REV.:
TDI-223	D
SCALE:	SHEET
1:2	6 OF 6

TYPICAL HEAD ANCHORAGE

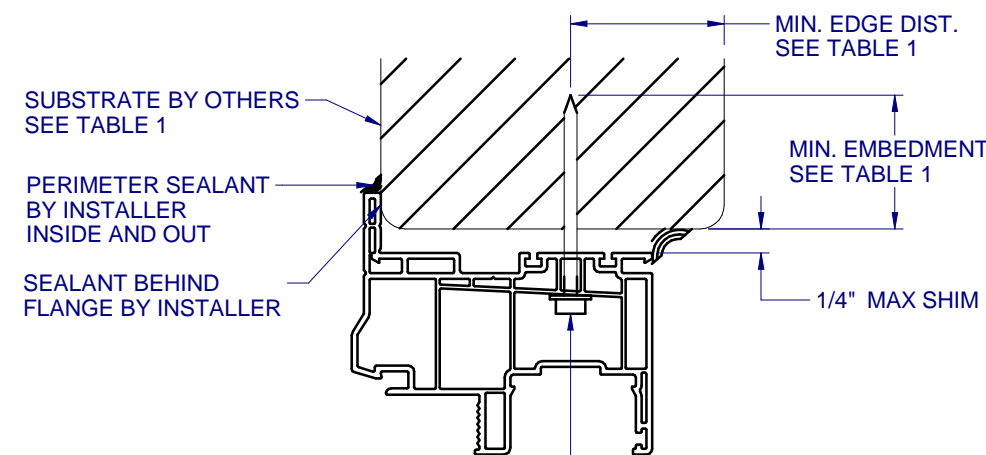

INSTALLATION ANCHOR
SEE TABLE 1

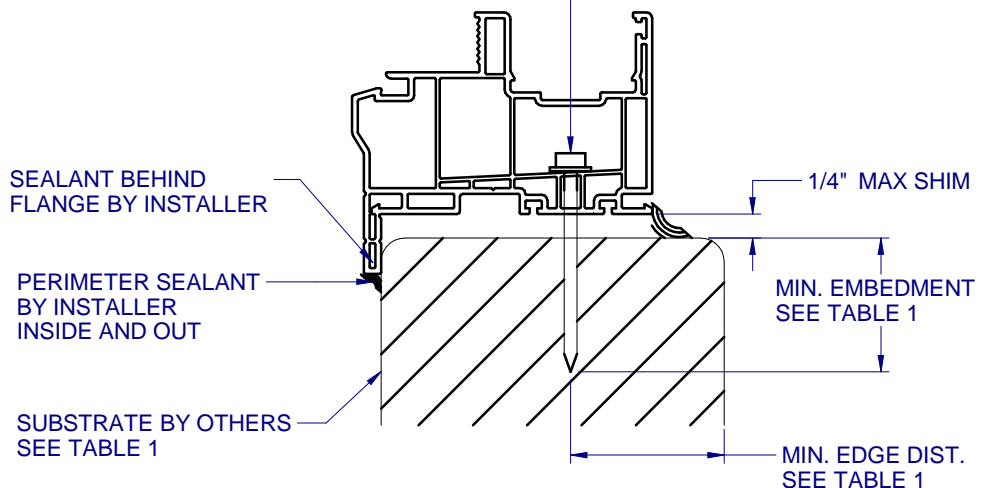

A
6 VERTICAL SECTION
TYPICAL SILL ANCHORAGE

MIN. EMBEDMENT
SEE TABLE 1

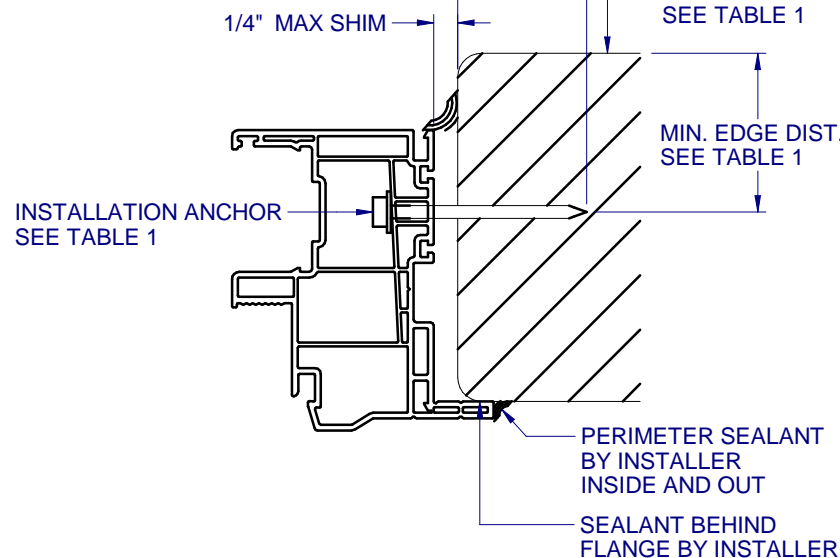

B
6 HORIZONTAL SECTION
TYPICAL JAMB ANCHORAGE

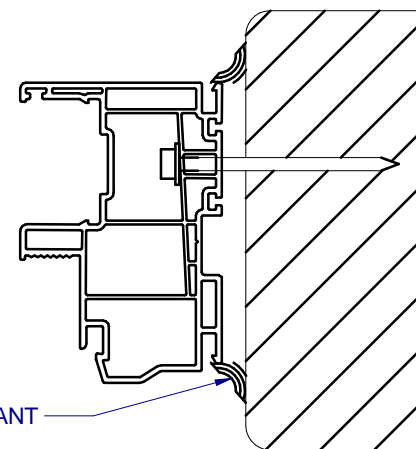

D
6 HORIZONTAL SECTION
BOX FRAME INSTALLATION
HEAD AND SILL SIMILAR FOR BOX INSTALLATION

MIN. EDGE DIST.
SEE TABLE 1

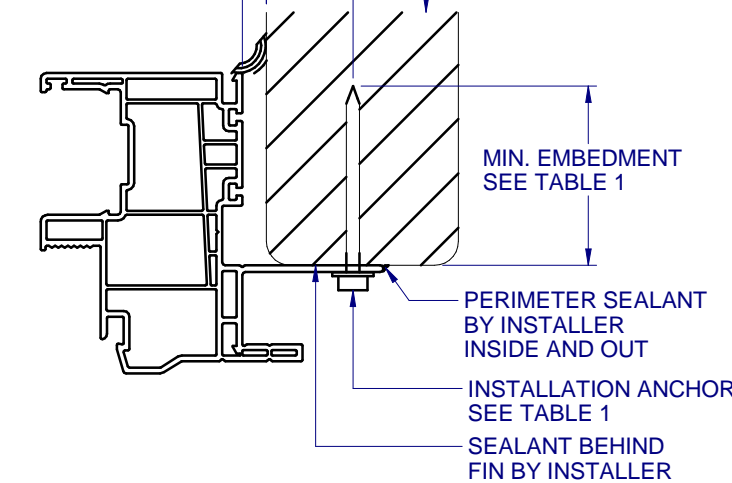

C
6 HORIZONTAL SECTION
TYPICAL FIN ANCHORAGE
HEAD AND SILL SIMILAR FOR FIN INSTALLATION

MIN. EDGE DIST.
SEE TABLE 1

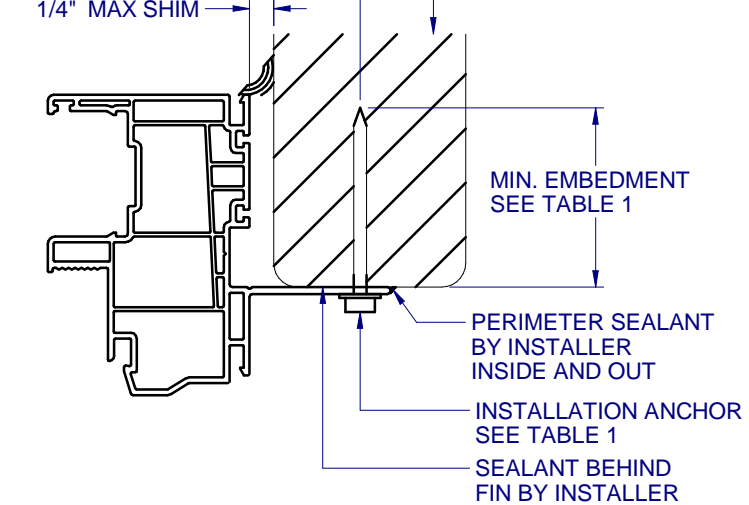

E
6 HORIZONTAL SECTION
TYPICAL FIN ANCHORAGE
HEAD AND SILL SIMILAR FOR FIN INSTALLATION

TABLE 1: APPROVED INSTALLATION FASTENERS

FRAME TYPE	SUBSTRATE TYPE	ANCHOR TYPE	MIN. EMBEDMENT	MIN. EDGE DIST.
FLANGE	CONCRETE (2.0 KSI MIN.)	3/16" ITW TAPCON	1-1/2"	1-1/8"
FLANGE	HOLLOW OR GROUT-FILLED CMU (117 PCF MIN.)	3/16" ITW TAPCON	1"	2"
FLANGE	CONCRETE (2.85 KSI MIN.)	3/16" ELCO ULTRACON	1"	1"
FLANGE	GROUT-FILLED CMU (ASTM C-90)	3/16" ELCO ULTRACON	1-1/4"	2-1/2"
FLANGE	2X MIN. SOUTHERN PINE (G=0.55)	3/16" ITW TAPCON OR ELCO ULTRACON	1-3/8"	7/8"
FLANGE	2X MIN. SOUTHERN PINE (G=0.55)	#10 WOOD SCREW	1-3/8"	7/8"
FLANGE	16 GAUGE (0.060") MIN. STEEL STUD (33 KSI YIELD MIN)	#10-16 HILTI KWIK-FLEX OR ITW TEKS SELF-DRILLING SCREW	FULL THREAD THRU 0.060"	7/16"
FLANGE	1/8" ALUM. (6063-T5 MIN.) OR 1/8" STEEL (33 KSI MIN.)	#10 GRADE 5 SELF-TAPPING / DRILLING SCREW	FULL THREAD THRU 0.125"	7/16"
FIN	2X MIN. SOUTHERN PINE (G=0.55)	#8 WOOD SCREW	1-1/2"	1/2"

FLANGE REMOVAL NOTE: PARTIALLY OR FULLY REMOVING THE FLANGE, UP TO AND INCLUDING A BOX-FRAME APPLICATION IS ACCEPTABLE PROVIDED:

- MIN. 1/4" FILLET OF CONSTRUCTION-GRADE ADHESIVE CAULK IS APPLIED INSIDE AND OUT, FULL PERIMETER, BY INSTALLER.
- PRODUCT ANCHORAGE IS IN ACCORDANCE WITH REQUIREMENTS AS SHOWN FOR FLANGE WINDOWS.