



Bringing quality to light.

10250 Philipp Parkway
Streetsboro, Ohio 44241

"BARCELONA" Model "SH30P" SINGLE HUNG WINDOW "NON-IMPACT"

EVALUATED FOR USE IN THE STATE OF TEXAS

TDI WIN-2353

The Single Hung Window described herein complies with the 2018 International Residential Code (IRC), Sections R301 & R609 and the 2018 International Building Code (IBC), Sections 1404.13, 1609, 1709.5, 2403 and 2404 subject to the following conditions:

1. Anchors shall be as listed and spaced as shown in the details. Anchor embedment to base material shall be beyond wall dressing or stucco.
2. When used in areas requiring wind-borne debris protection this product is required to be protected with an impact resistant covering that complies with Section R301.2.1.2 of the IRC and Section 1609.2 of the IBC.
3. Allowable design pressure requirements must be equal to or less than the design pressure rating shown in the design pressure chart, sheet 1 of this drawing.
4. Conditions not covered by this drawing are subject to further engineering analysis.

TABLE OF CONTENTS	
SHEET#	DESCRIPTION
1	Typical elevations, design pressures & general notes
2	Horizontal cross sections
3	Vertical cross sections
4	Buck and frame anchoring
5	Bill of materials, components & glazing details

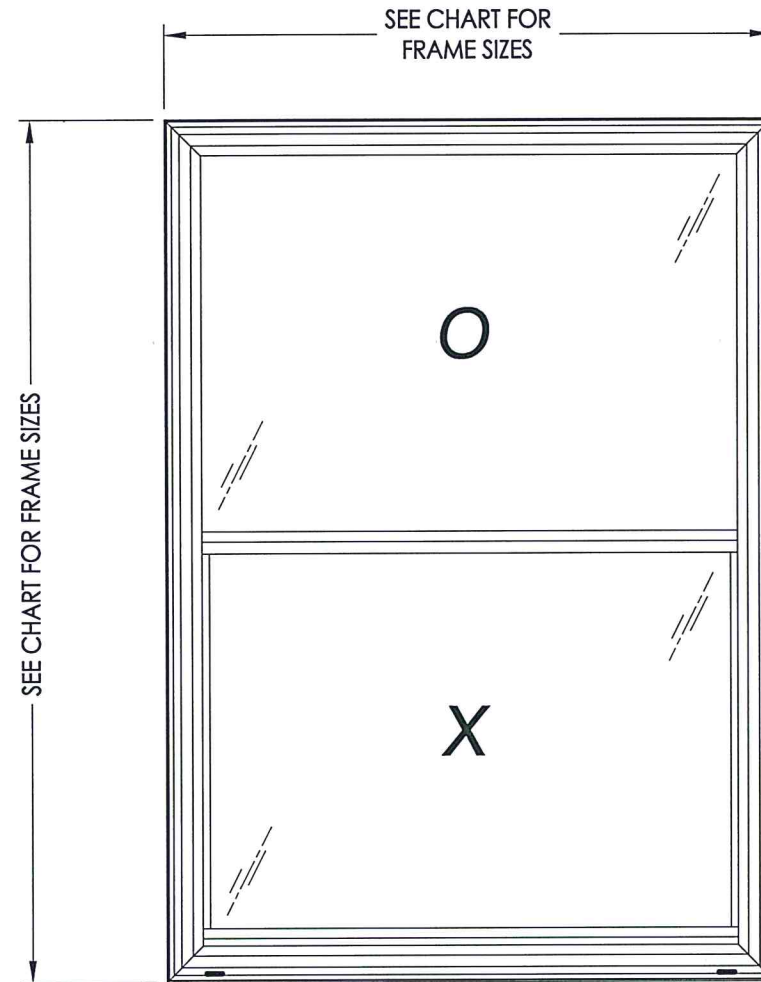

MAX. FRAME DIMENSION	MAX. D.L.O. DIMENSION	GLASS TYPE	DESIGN PRESSURE (PSF)	
			POSITIVE	NEGATIVE
32.0" X 84.0"	25.5" x 37.188"	G1	+45.0	-45.0
40.0" X 96.0"	33.5" x 43.125"	G1	+30.0	-30.0
40.0" X 63.0"	33.5" x 26.5"	G1	+55.0	-55.0
54.0" X 76.0"	47.5" x 33.0"	G1	+45.0	-45.0



Documents Prepared By: Lyndon F. Schmidt, P.E.
TEXAS P.E. #104123

RW BUILDING CONSULTANTS, INC.
P.O. Box 230 Valrico FL 33595
Phone No.: 813.659.9197

TEXAS BOARD OF PROFESSIONAL ENGINEERS
CERTIFICATE OF REGISTRATION # F-11852

PRODUCT: SOFT-LITE WINDOWS

PART OR ASSEMBLY: TYPICAL ELEVATION, DESIGN PRESSURES & GENERAL NOTES

NO.	DATE	REVISIONS
1	5/10/21	UPDATE TO 2018 IBC/IRC

DATE: 6/25/18
SCALE: N.T.S.
DWG. BY: JK
CHK. BY: LFS
DRAWING NO.: TX-4852
SHEET 1 OF 5

Z:\Clients\Soft-Lite Permanent\B - Texas Dept of Ins\WIN-2353 ID 7348 Barcelona SH30P Single Hung Window Non-Impact\Drawings\TX-4852.dwg

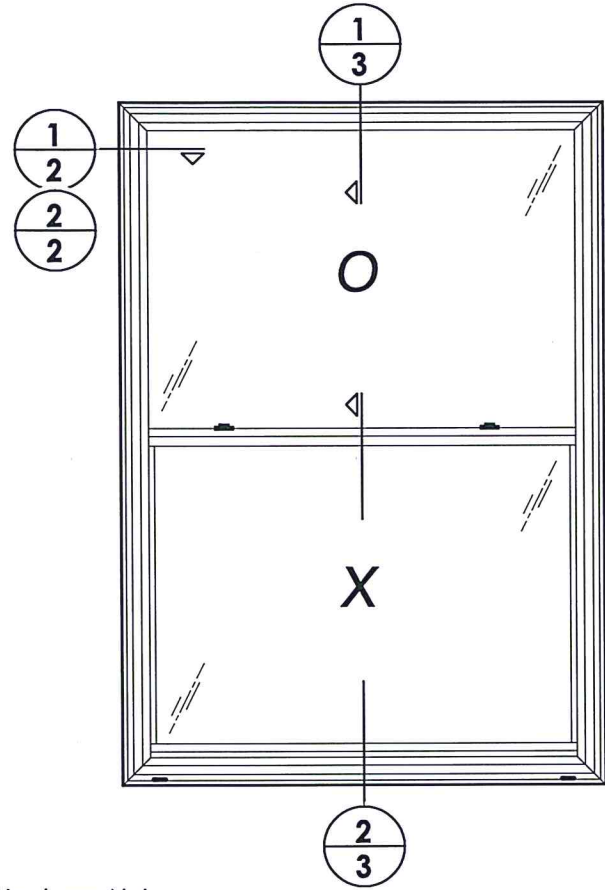

Hardware Notes:

- 1. Locks (2) located on lock rail 10" from each jamb.

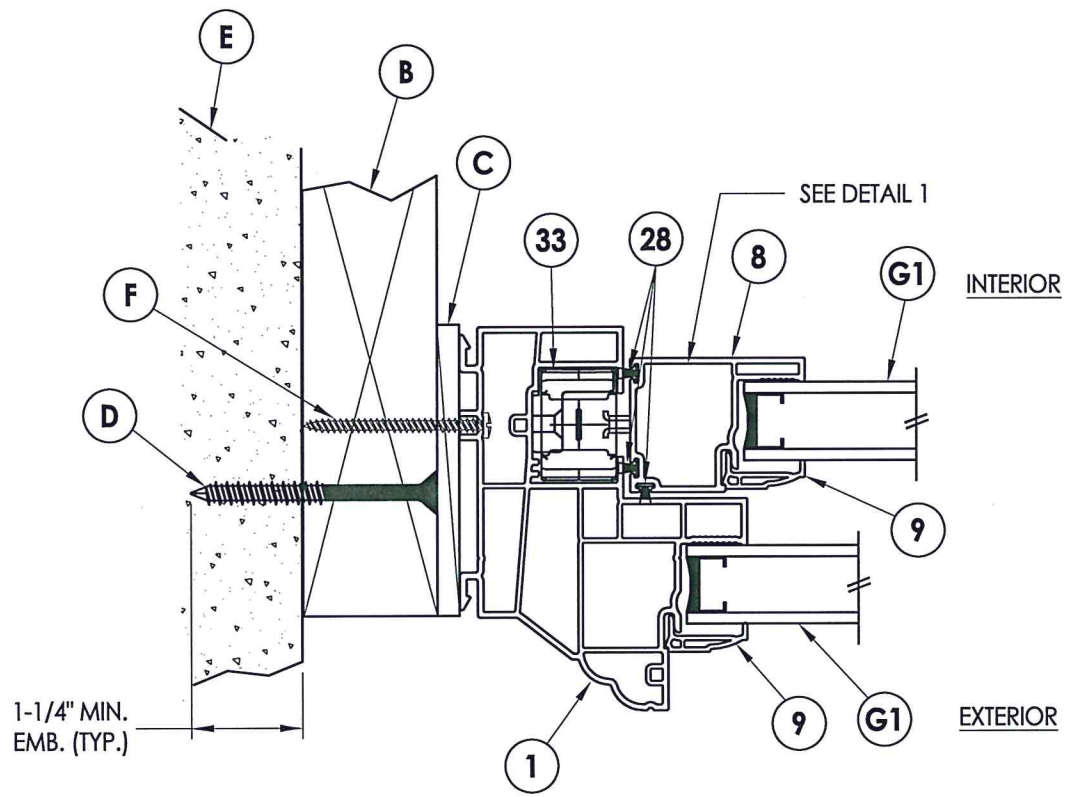

2 HORIZONTAL CROSS SECTION
Shown w/ 2X Buck Masonry Construction

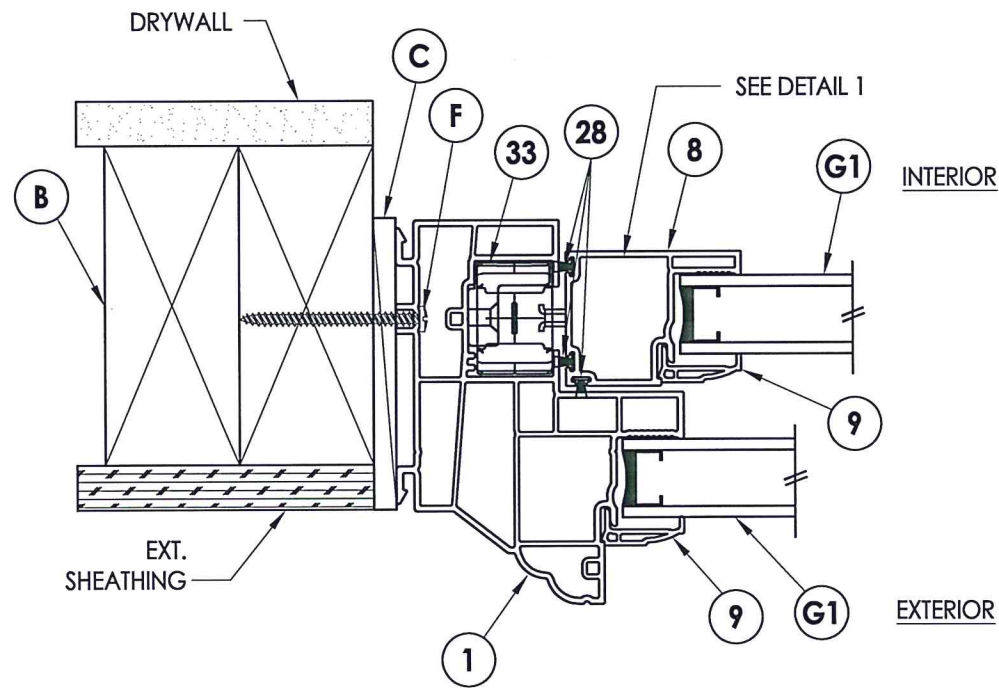

1 HORIZONTAL CROSS SECTION
Shown w/ Stud Framing

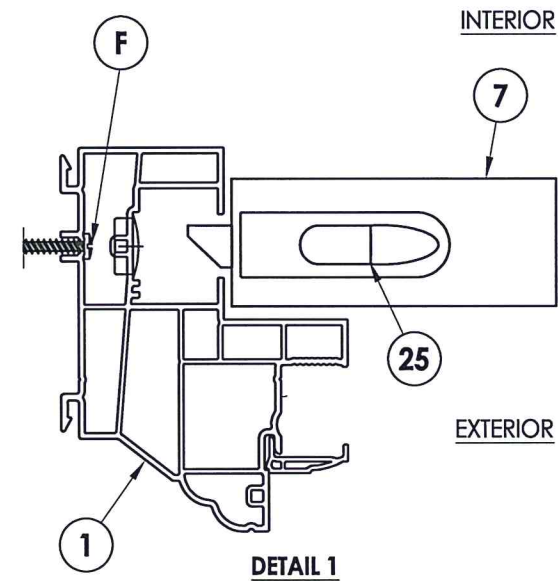

DETAIL 1

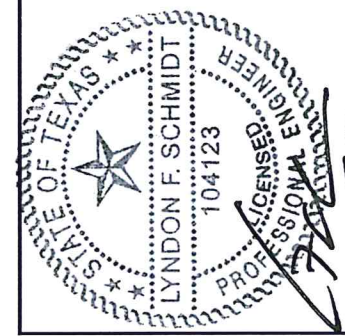

Documents Prepared By: Lyndon F. Schmidt, P.E.
TEXAS P.E. #104123

RW BUILDING CONSULTANTS, INC.
P.O. Box 230 Valrico FL, 33595
Phone No.: 813.659.9197
TEXAS BOARD OF PROFESSIONAL ENGINEERS
CERTIFICATE OF REGISTRATION # F-11852

PRODUCT:	SOFT-LITE WINDOWS
PART OR ASSEMBLY:	HORIZONTAL CROSS SECTIONS

NO.	DATE	BY	REVISIONS
1	5/10/21	LFS	UPDATE TO 2018 IBC/IRC

DATE:	6/25/18
SCALE:	N.T.S.
DWG. BY:	JK
CHK. BY:	LFS
DRAWING NO.:	TX-4852
SHEET	2 OF 5

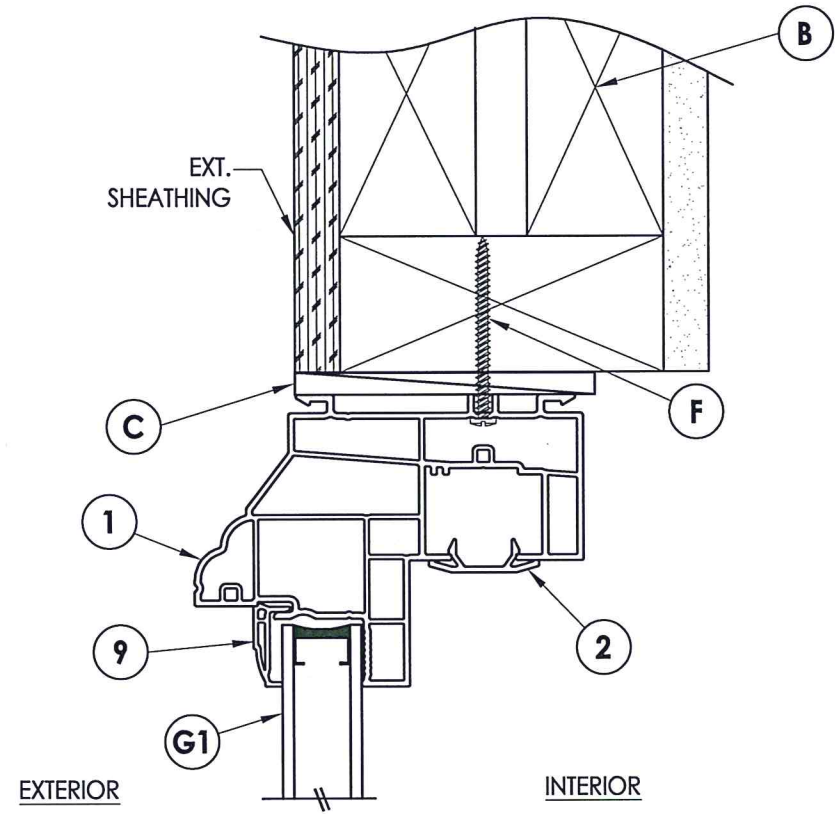

1 VERTICAL CROSS SECTION
3 Shown w/ Stud Framing

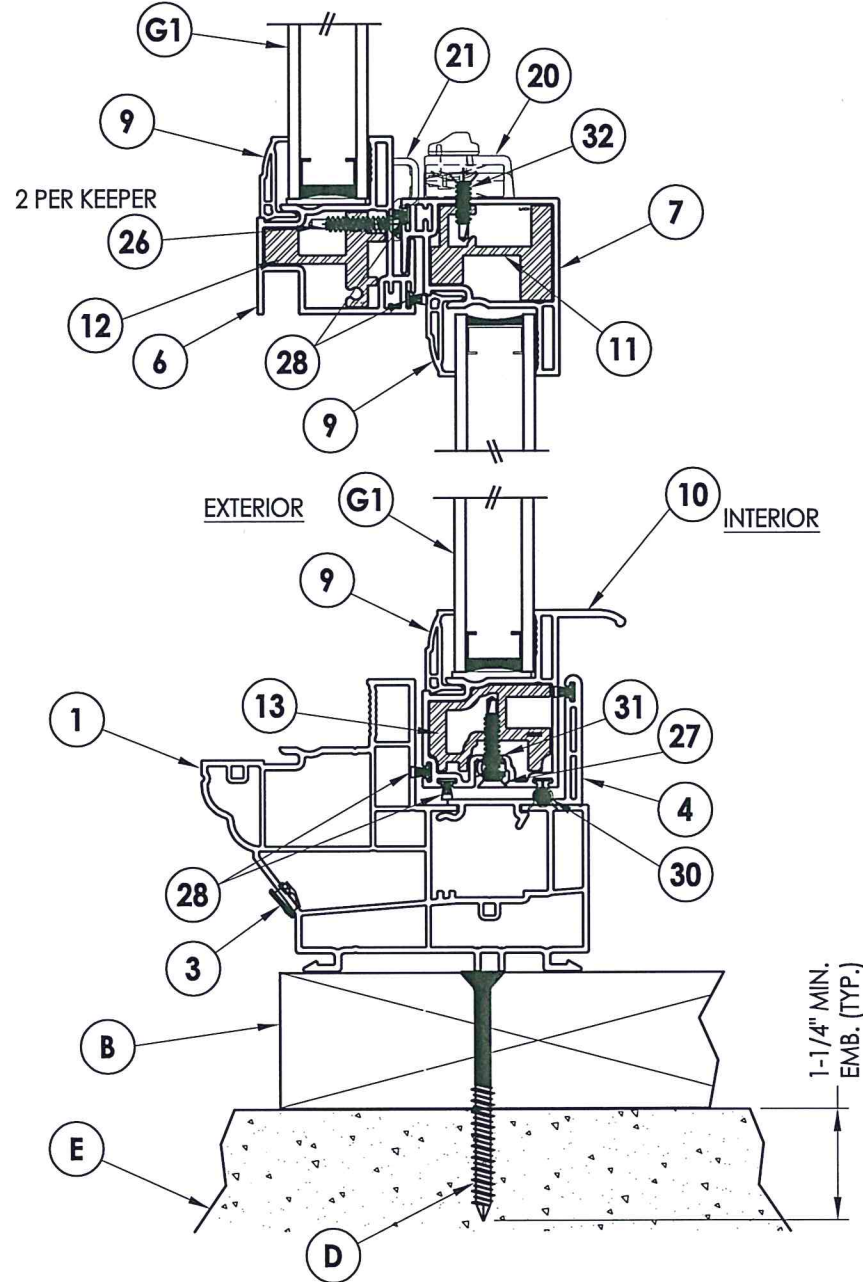

2 VERTICAL CROSS SECTION
3 2X Buck Construction



Documents Prepared By: Lyndon F. Schmidt, P.E.
 TEXAS P.E. #104123

RW BUILDING CONSULTANTS, INC.
 P.O. Box 230 Valrico FL 33595
 Phone No.: 813.659.9197
 TEXAS BOARD OF PROFESSIONAL ENGINEERS
 CERTIFICATE OF REGISTRATION # F-11852

PRODUCT:	SOFT-LITE WINDOWS	
PART OR ASSEMBLY:	VERTICAL CROSS SECTIONS	
NO.	DATE	REVISIONS
1	5/10/21	UPDATE TO 2018 IBC/IRC
		LFS
		BY
DATE: 6/25/18		
SCALE: N.T.S.		
DWG. BY: JK		
CHK. BY: LFS		
DRAWING NO.: TX-4852		
SHEET 3 OF 5		

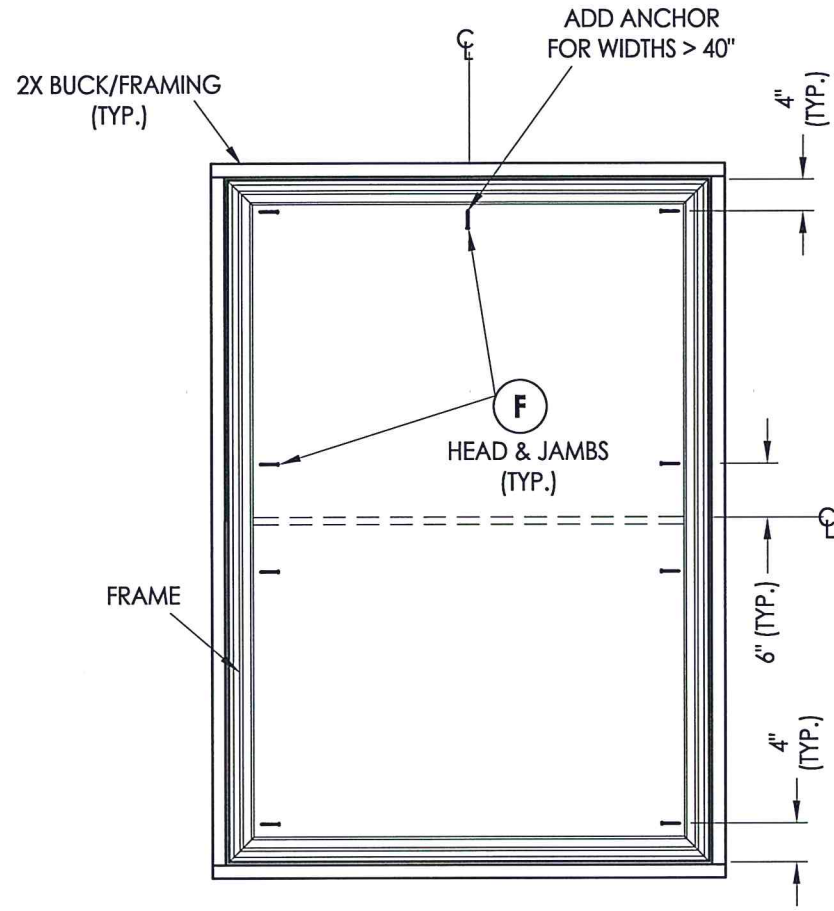
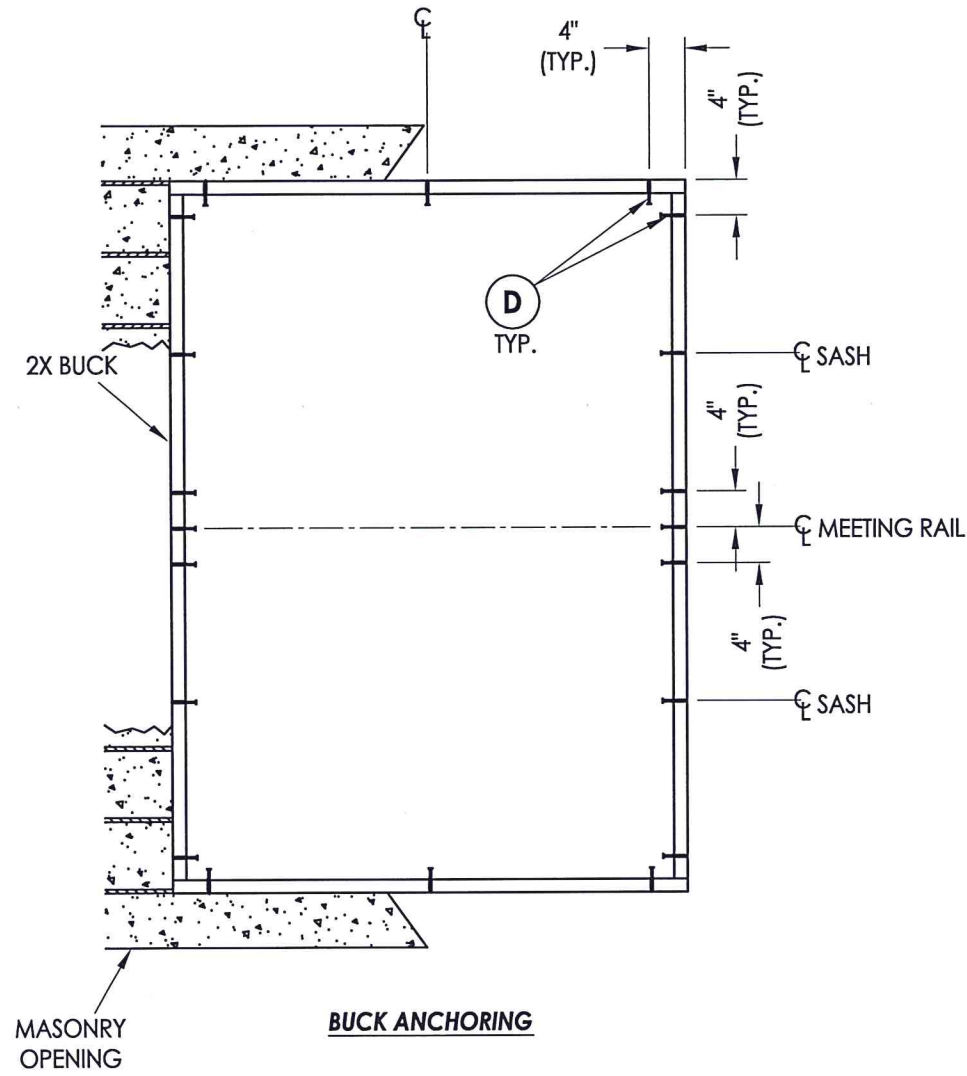

CONCRETE ANCHOR NOTES:

1. Concrete anchor locations at the corners may be adjusted to maintain the min. edge distance to mortar joints.
2. Concrete anchor locations noted as "MAX. ON CENTER" must be adjusted to maintain the min. edge distance to mortar joints, additional concrete anchors may be required to ensure the "MAX. ON CENTER" dimension are not exceeded.
3. Concrete anchor table:

ANCHOR TYPE	ANCHOR SIZE	MIN. EMBEDMENT	MIN. CLEARANCE TO MASONRY EDGE	MIN. CLEARANCE TO ADJACENT ANCHOR
ITW TAPCON®	1/4"	1-1/4"	2"	4"

WOOD SCREW INSTALLATION NOTES:

1. Maintain a minimum 5/8" edge distance, 1" end distance, & 1" o.c. spacing of wood screws to prevent the splitting of wood.

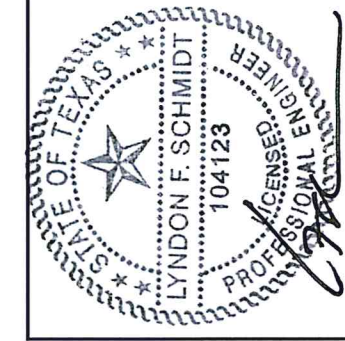

Documents Prepared By: Lyndon F. Schmidt, P.E.
TEXAS P.E. #104123

RW BUILDING CONSULTANTS, INC.
P.O. Box 230 Valrico FL, 33595
Phone No.: 813.659.9197

TEXAS BOARD OF PROFESSIONAL ENGINEERS
CERTIFICATE OF REGISTRATION # F-11852

PRODUCT:	SOFT-LITE WINDOWS	
PART OR ASSEMBLY:	BUCK & FRAME ANCHORING	
NO.	DATE	BY
1	5/10/21	LFS
UPDATE TO 2018 IBC/IRC		
REVISIONS		
DATE:	6/25/18	
SCALE:	N.T.S.	
DWG. BY:	JK	
CHK. BY:	LFS	
DRAWING NO.:	TX-4852	
SHEET	4	OF 5

BILL OF MATERIALS		
ITEM #		MATERIAL
B	2X FRAMING (SG >= 0.42)	WOOD
C	1/4" MAX. SHIM SPACE	-
D	1/4" X 2-3/4" PFH ITW CONCRETE SCREW	STEEL
E	MASONRY - 3,000 PSI MIN. CONCRETE CONFORMING TO ACI 301 OR HOLLOW BLOCK CONFORMING TO ASTM C90	CONCRETE
F	#8 X 2" TRUSS HEAD SMS (1-3/8" MIN. EMBEDMENT)	STEEL
1	FRAME*	PVC
2	PW COVER*	PVC
3	WEEP HOLE COVER*	PVC
4	SILL ADAPTER*	PVC
6	KEEPER RAIL*	PVC
7	LOCK RAIL*	PVC
8	PLAIN STILE*	PVC
9	GLAZING BEAD*	PVC
10	BOTTOM LIFT RAIL*	PVC
11	REINFORCEMENT (6065-T5 ALUM)	ALUM.
12	REINFORCEMENT (6065-T5 ALUM)	ALUM.
13	REINFORCEMENT (6065-T5 ALUM)	ALUM.
20	LOCK	-
21	LOCK KEEPER	-
25	TILT LATCH	-
26	#8 X 1" PFH TEK	STEEL
27	#6 X 1" PFH TEK	STEEL
28	WEATHERSTRIP (187-270 TRI-FIN)	-
30	BULB SEAL	-
31	PIVOT BAR	STEEL
32	#7 X 3/4" PFH TEK	STEEL
33	BALANCER BRACKET	-

* THE APPROVED WHITE RIGID PVC EXTERIOR EXTRUSIONS FOR WINDOWS ARE TO BE PRODUCED BY EXTRUDERS LICENSEES IN "AAMA CERTIFICATIONS PROGRAMS FOR RIGID PVC EXTRUSIONS".

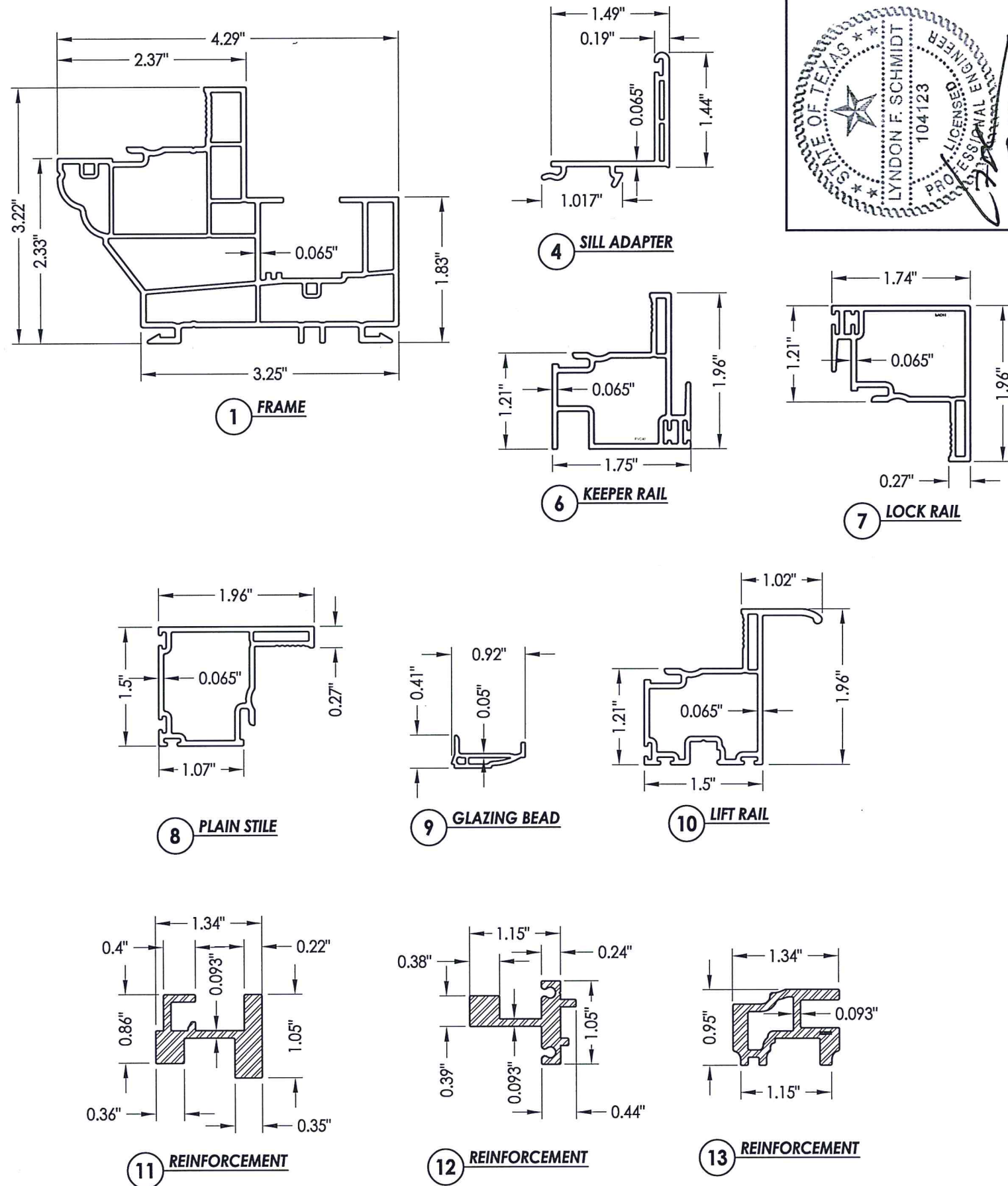
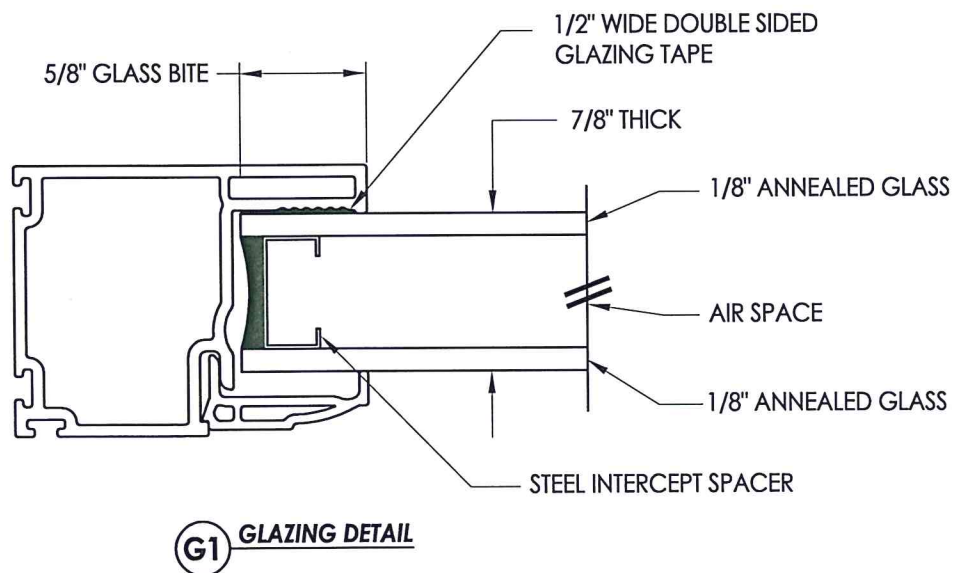

Documents Prepared By: Lyndon F. Schmidt, P.E.
TEXAS P.E. #104123

RW BUILDING CONSULTANTS, INC.
P.O. Box 230 Valrico FL 33595
Phone No.: 813.659.9197

TEXAS BOARD OF PROFESSIONAL ENGINEERS
CERTIFICATE OF REGISTRATION # F-11852

PRODUCT:	SOFT-LITE WINDOWS	
PART OR ASSEMBLY:	BILL OF MATERIALS, COMPONENTS AND GLAZING DETAIL	
NO.	DATE	BY
1	5/10/21	LFS
UPDATE TO 2018 IBC/IRC		
REVISIONS		
DATE:	6/25/18	
SCALE:	N.T.S.	
DWG. BY:	JK	
CHK. BY:	LFS	
DRAWING NO.:	TX-4852	
SHEET	5	OF 5