

GENERAL NOTES

1. THE PRODUCT SHOWN HEREIN IS DESIGNED AND MANUFACTURED TO COMPLY WITH THE REQUIREMENTS OF THE 2018 INTERNATIONAL BUILDING CODE AND INTERNATIONAL RESIDENTIAL CODE.
2. THIS PRODUCT IS NON-IMPACT RESISTANT AND REQUIRES THE USE OF IMPACT PROTECTIVE DEVICES (SHUTTERS) IN WINDBORNE DEBRIS REGIONS.
3. THE DESIGN PRESSURES INDICATED IN THIS DRAWING ARE AS LIMITED BY ASTM E-1300 GLASS TABLES, AND TESTED WATER AND STRUCTURAL PRESSURES.
4. THIS DOCUMENT ADDRESSES PRODUCT ANCHORAGE TO ACHIEVE THE INDICATED DESIGN PRESSURES AT THE INDICATED SIZES, IN THE CONFIGURATION SHOWN IN THE ELEVATIONS. INSTALL PRODUCTS WITH MAXIMUM SHIM GAP, MINIMUM EDGE DISTANCE AND EMBEDMENT, AND WITH FASTENER TYPE AS SHOWN IN THE DETAILS AND AS INDICATED IN TABLE 1. FOR FULL PRODUCT CONSTRUCTION DETAILS SEE MOLIMO TEST REPORTS 1380.02/04-106-11, AND 1421.02/04-106-11.
5. INSTALLED GLAZING SHALL MEET ASTM E-1300 FOR THE APPLICABLE DESIGN PRESSURES AND WINDOW SIZE. MINIMUM GLAZING IS AS TESTED WITH 1" OVERALL DUAL PANE INSULATING GLASS USING GED STAINLESS STEEL INTERCEPT SPACER WITH TWO LITES OF 3/16" ANNEALED GLASS FOR 54"X77" SIZE AT DP60, AND TWO LITES OF 1/4" ANNEALED GLASS FOR 72"X72" SIZE AT DP50. GLAZE WITH SIKAFLEX 552 BACKBEDDING W/ 1/2" GLASS BITE.
6. THE 4/3 ALLOWABLE STRESS INCREASE FACTOR (SHORT-TERM INCREASE FACTOR) HAS NOT BEEN USED IN THE ANCHOR ANALYSIS FOR THIS SYSTEM. THE 1.6 Cd FACTOR WAS USED IN THE ANALYSIS OF ANCHORAGE INTO WOOD SUBSTRATE.
7. THE OPENING SUBSTRATE MATERIALS (FRAMING, MASONRY, BUCKS) AND ATTACHMENT OF BUCKS TO THE SUBSTRATE ARE BY OTHERS AND SHALL BE VERIFIED BY THE ARCHITECT OR ENGINEER OF RECORD OR AS APPROVED BY THE AUTHORITY HAVING JURISDICTION (AHJ). BUCKING, OPENINGS, & BUCKING FASTENERS MUST BE PROPERLY DESIGNED & INSTALLED BY OTHERS IN ACCORDANCE WITH THE FBC TO TRANSFER SUPERIMPOSED LOADS TO THE STRUCTURE. WITH MASONRY OPENINGS, WOOD BUCKS ARE OPTIONAL.
8. DISSIMILAR MATERIALS THAT COME INTO CONTACT SHALL BE COATED OR OTHERWISE PROTECTED TO PREVENT GALVANIC REACTIONS. WOOD BUCKS, IF USED, SHALL BE PRESSURE TREATED, WITH EITHER A TREATMENT OR COATING COMPATIBLE WITH THIS PRODUCT.
9. ALL ANCHORS USED SHALL BE OF A MATERIAL OR HAVE A COATING COMPATIBLE WITH THE PRESSURE TREATED WOOD BUCKS AND ALL OTHER WINDOW MATERIALS.
10. ALL HARDWARE & FASTENERS SHALL BE IN ACCORDANCE WITH THESE DRAWINGS, OR AS APPROVED, SIGNED, AND SEALED BY A TEXAS REGISTERED PROFESSIONAL ENGINEER ON A SITE-SPECIFIC BASIS.
11. SEALING AND FLASHING STRATEGIES FOR OVERALL WATER INFILTRATION RESISTANCE OF THE INSTALLED PRODUCT SHALL BE THE RESPONSIBILITY OF OTHERS AND ARE NOT ADDRESSED BY THIS DOCUMENT.
12. FOR ADDITIONAL REQUIREMENTS SEE GENERAL ANCHOR NOTES, SHEET 3.
13. WIDTH AND HEIGHT AS SHOWN IN THE ELEVATIONS MAY BE TRANSPOSED; IF SO THEN 21" MAX. ON CENTER ANCHOR SPACING APPLIES TO THE JAMB AND THE SMALLER ANCHOR SPACING APPLIES TO THE HEAD/SILL.

WINFORCE PICTURE WINDOW (4764/4722), NON-IMPACT

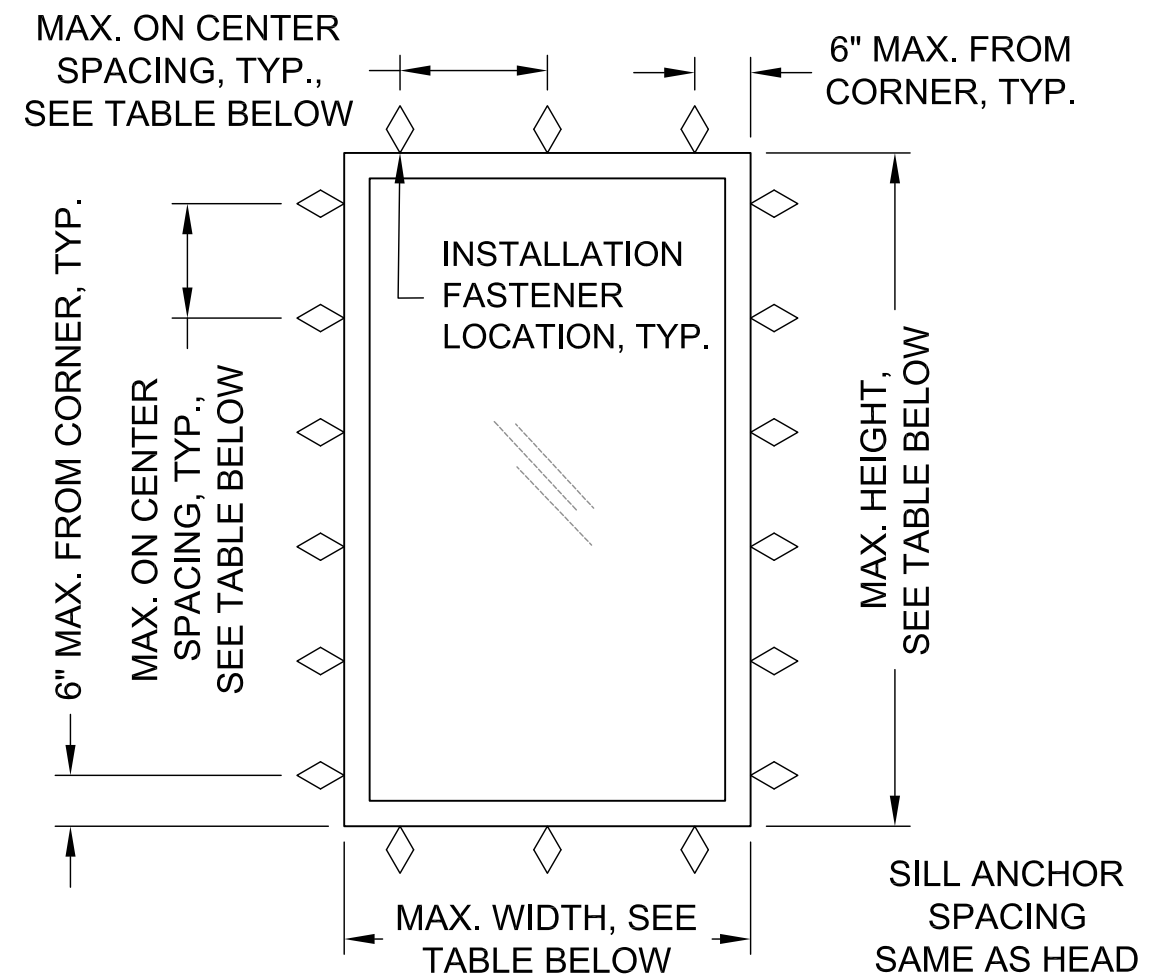

**EQUAL LEG / FLANGE ELEVATION
SEE DETAILS SHEET 2**

MAX. SIZE*	DESIGN PRESSURE RATING	MAX. O.C. SPACING	IMPACT RATING
54" X 77"	+60/-60 PSF	12"	NONE
72" X 72"	+50/-50 PSF	10-1/2"	

*NOTE: WIDTH AND HEIGHT MAY BE SWAPPED

NORTHEAST BUILDING PRODUCTS 4280 Aramingo Ave., Philadelphia, PA 19124 Ph. (215) 535-7110 www.nbpwindows.com	
SHEET DESCRIPTION: NOTES, ELEVATIONS	DATE DRAWN: 4/13/2017
REV. A: UPDATE TO 2018 IBC/IRC	SCALE: NTS
DRAWING: TDI-4764-PW-NI	SHEET: 1 OF 3



2/19/2021
Lucas A. Turner, P.E.
TX PE #115094
2428 Old Natchez Trc Trl
Camden, TN 38320
Ph. 941-380-1574

WINFORCE PICTURE WINDOW (4764/4722), NON-IMPACT

SEE GENERAL ANCHOR NOTES, SHEET 3.

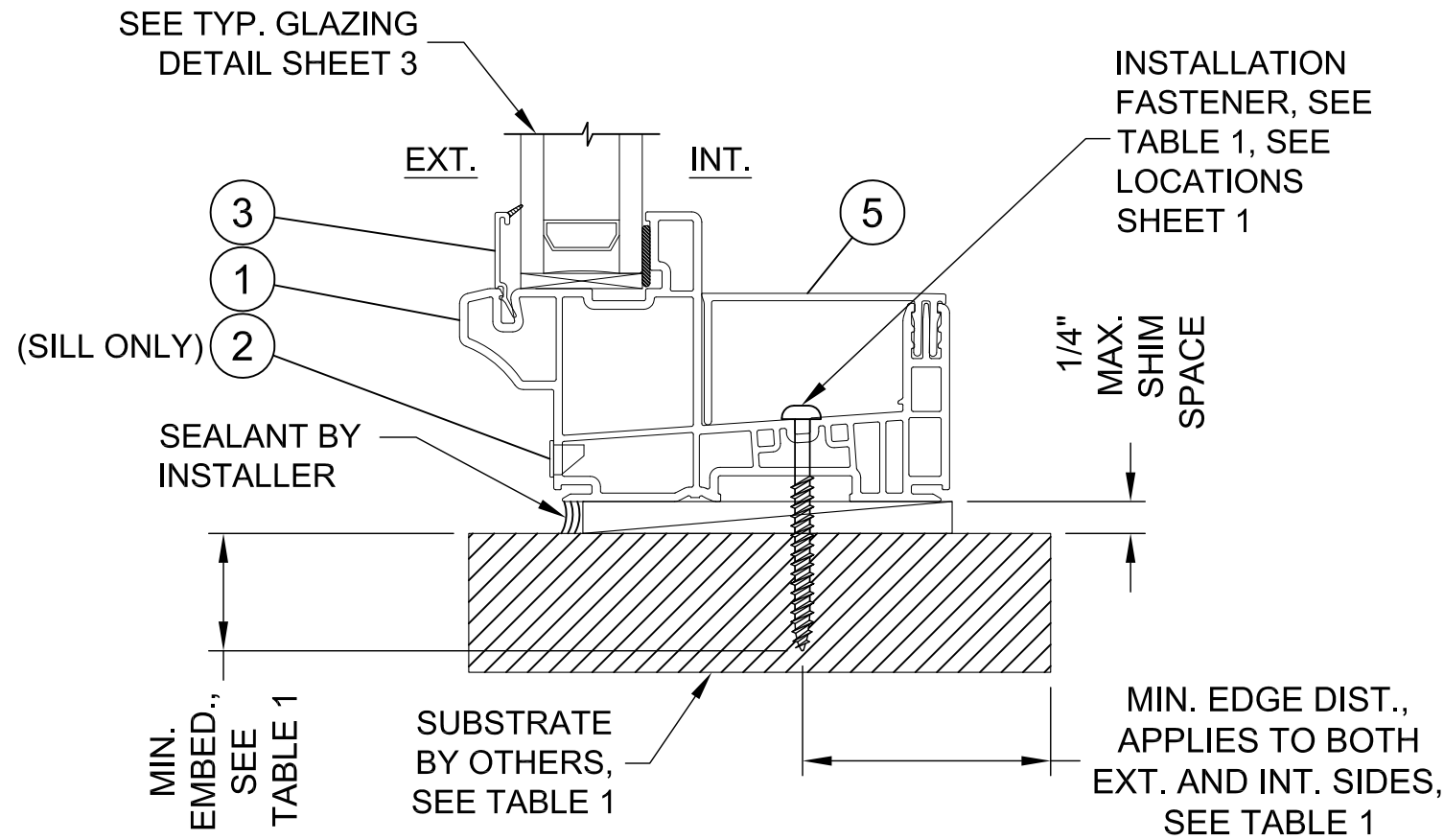

TYPICAL EQUAL LEG INSTALLATION HEAD / SILL / JAMB

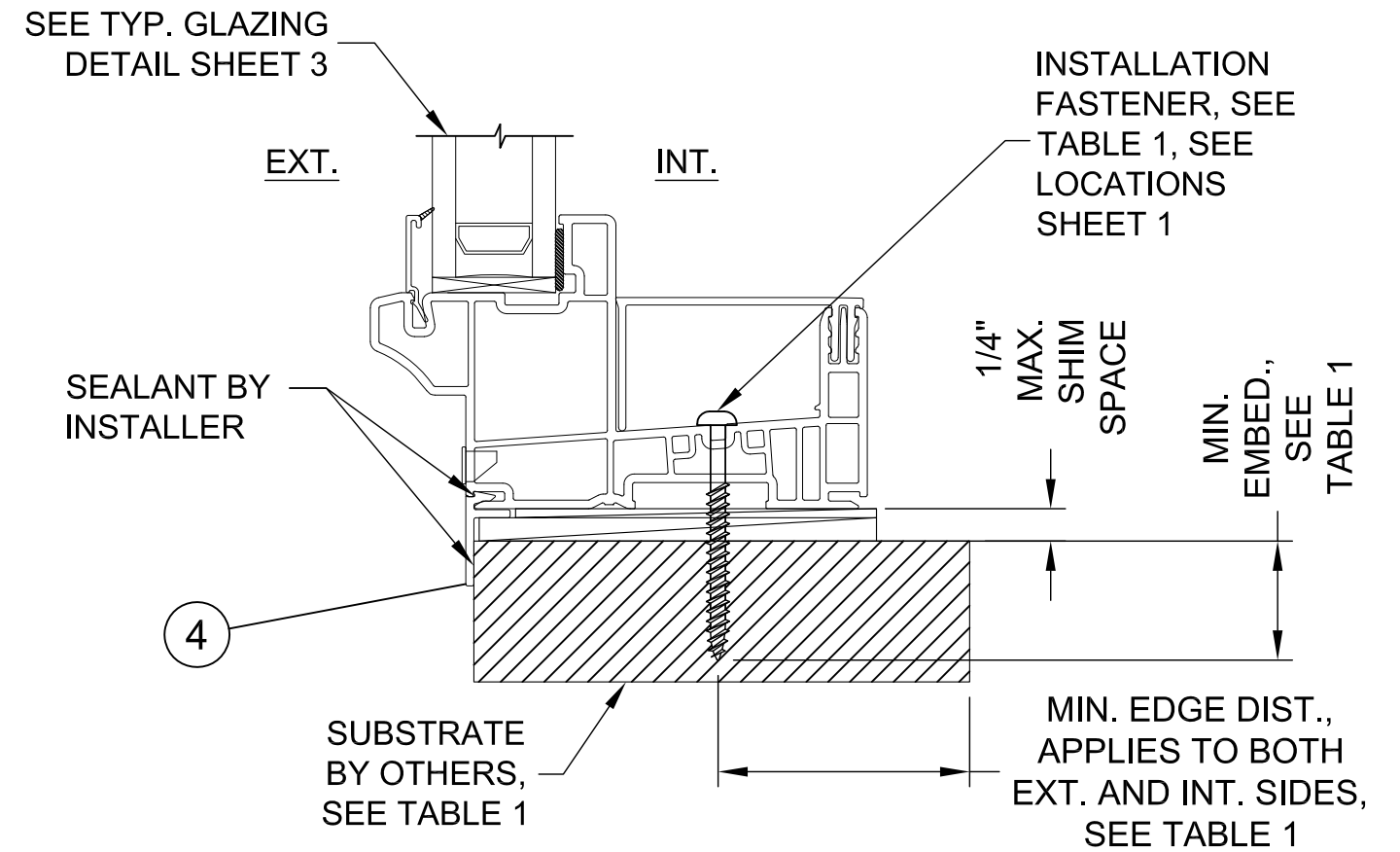

TYPICAL FLANGE INSTALLATION HEAD / SILL / JAMB

TABLE 1: EQUAL LEG / FLANGE FRAME INSTALLATION ANCHOR REQUIREMENTS TABLE
NOTE: ALL ANCHORS ARE PAN HEAD OR HEX WASHER HEAD

SUBSTRATE TYPE	ANCHOR TYPE	MIN. EMBED.	MIN. EDGE DIST.
CONCRETE (2.0 KSI MIN)	3/16" ITW TAPCON	1-1/2"	1 1/8"
HOLLOW OR GROUT-FILLED CMU (117 PCF MIN.)	3/16" ITW TAPCON	1"	2"
CONCRETE (2.85 KSI MIN.)	3/16" ELCO ULTRACON	1"	1"
2X MIN. SOUTHERN PINE WOOD (G=0.55)	#10 GRADE 5 WOOD SCREW	1-1/2"	1"
16 GAUGE (0.060") MIN. STEEL STUD, 33KSI YIELD MIN., OR 1/8" ALUM. 6063-T5 MIN.	#10-16 HILTI KWIK-FLEX OR ITW TEKS SELF-DRILLING SCREW	FULL	1/2"

NORTHEAST BUILDING PRODUCTS

4280 Aramingo Ave., Philadelphia, PA 19124
Ph. (215) 535-7110 www.nbpwindows.com

SHEET DESCRIPTION:
EQ. LEG / FLANGE INSTALLATION

DATE DRAWN:
4/13/2017

REV. A: UPDATE TO 2018 IBC/IRC

SCALE: NTS

DRAWING: TDI-4764-PW-NI

SHEET: 2 OF 3



2/19/2021
Lucas A. Turner, P.E.
TX PE #115094
2428 Old Natchez Trc Trl
Camden, TN 38320
Ph. 941-380-1574

WINFORCE PICTURE WINDOW (4764/4722), NON-IMPACT

BILL OF MATERIALS

ITEM NO.	DESCRIPTION	PART NO.	SOURCE	MATERIAL
1	HEAD/JAMB/SILL	10004764	DECEUNINCK	PVC
2	WEEP COVER	900-003	LAWRENCE	PLASTIC
3	GLAZING BEAD - 1" IG	10005464/10005144	DECEUNINCK	PVC
4	ADD ON FLANGE	10008341	DECEUNINCK	PVC
5	FRAME ADAPTER	10004722	DECEUNINCK	PVC

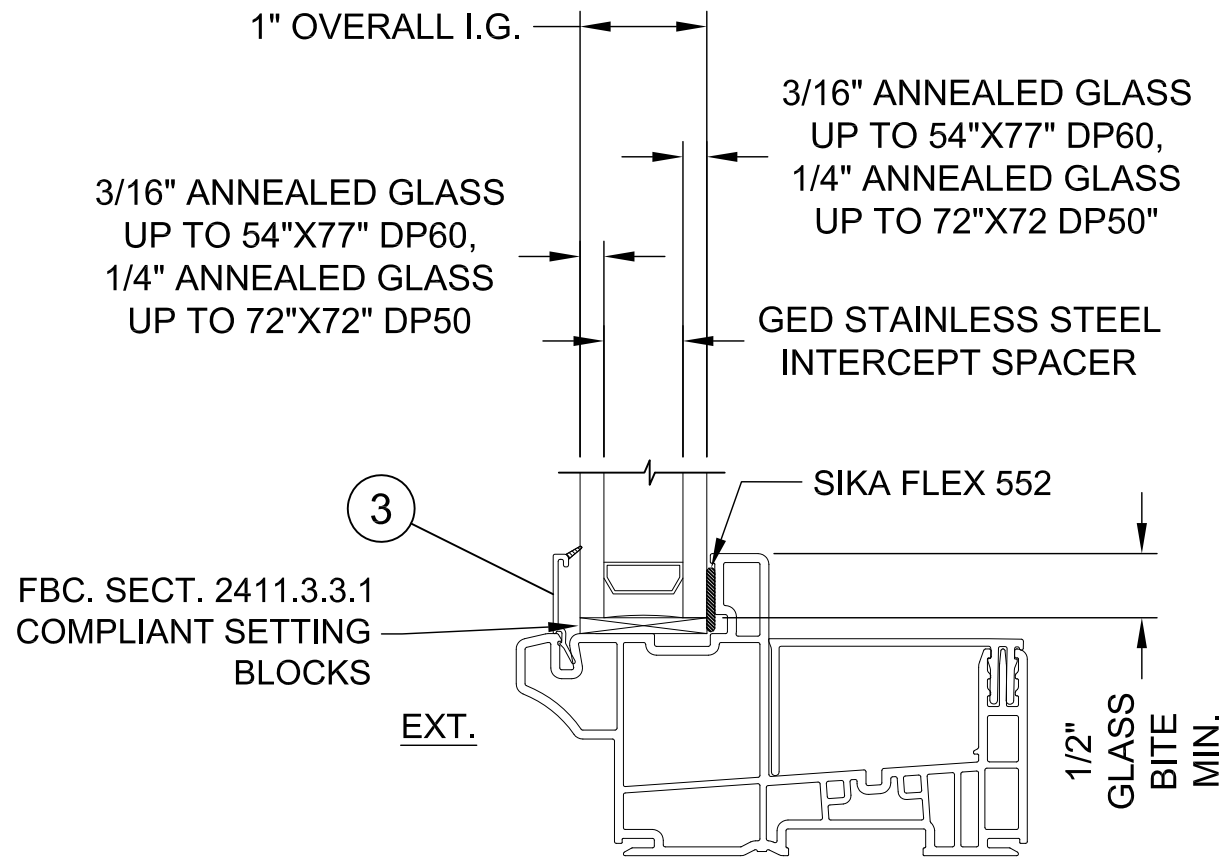

TYPICAL GLAZING DETAIL

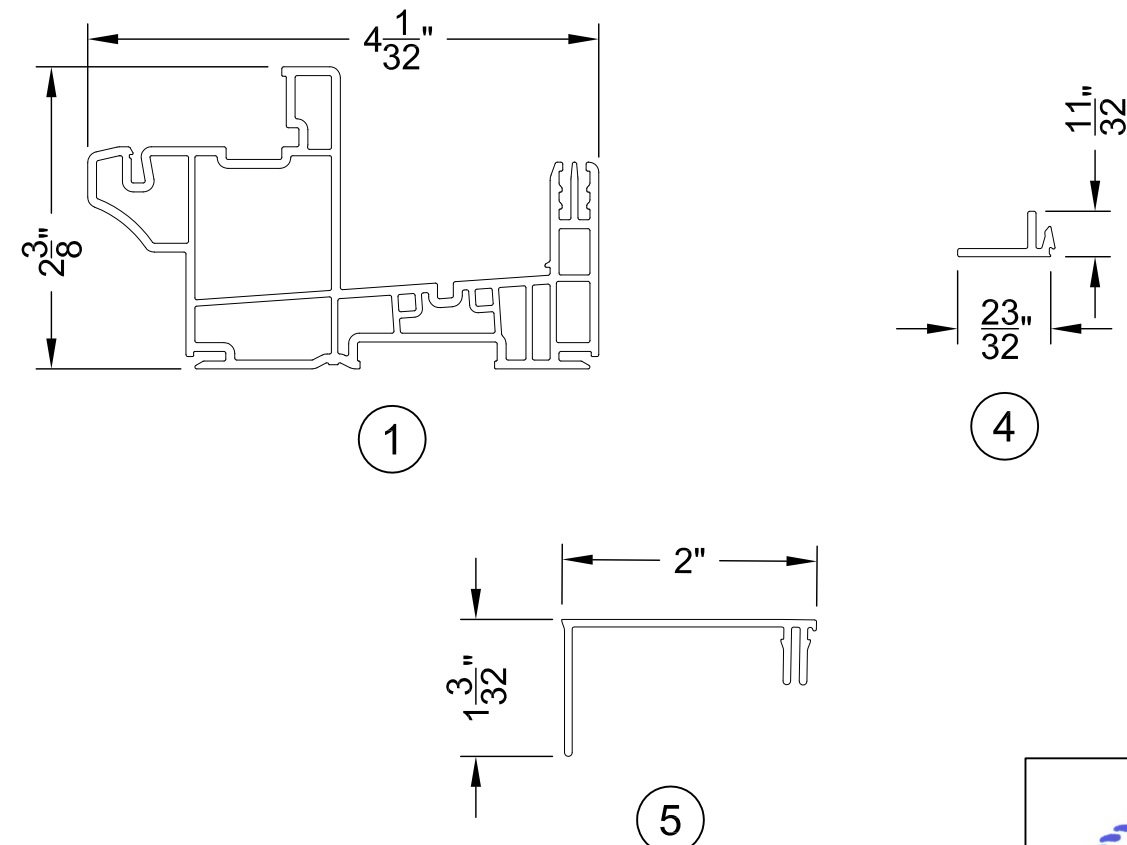

GENERAL ANCHOR NOTES:

1. INSTALL ONE ANCHOR AS INDICATED IN DETAILS ON SHEET 2 AT EACH LOCATION SHOWN IN THE ELEVATION ON SHEET 1.
2. INSTALL SHIMS AT EACH ANCHOR LOCATION WHERE A GAP OF 1/16" OR GREATER EXISTS BETWEEN PRODUCT FRAME AND SUBSTRATE.
3. SHIMS SHALL BE LOAD-BEARING (PLASTIC OR METALLIC) AND CAPABLE OF TRANSFERRING LOADS TO SUBSTRATE.
4. SPECIFIED ANCHOR EMBEDMENT TO SUBSTRATE SHALL BE BEYOND WALL FINISH OR STUCCO, BY OTHERS. FOR ATTACHMENT TO METAL SUBSTRATES ENSURE FULL THREAD ENGAGEMENT THROUGH METAL WALL WITH MIN. 3 THREADS BEYOND.
5. FOR MASONRY WITH WOOD BUCKS LESS THAN 1-1/2" THICK, EMBEDMENT SHALL BE BEYOND WOOD BUCKS AND INTO MASONRY. WOOD BUCKS ARE OPTIONAL WITH MASONRY INSTALLATIONS WHERE MASONRY EDGE DISTANCE CONDITIONS ARE MET WITH NO BUCKS. WOOD BUCKS 1-1/2" THICK OR GREATER SHALL HAVE EMBEDMENT INTO THE WOOD BUCKS.
6. ENSURE 3" MIN. ON-CENTER SPACING BETWEEN ANY TWO INSTALLATION ANCHORS.

NORTHEAST BUILDING PRODUCTS

4280 Aramingo Ave., Philadelphia, PA 19124
Ph. (215) 535-7110 www.nbpwindows.com

SHEET DESCRIPTION:
FIN INSTALL, GLAZING, BOM, DWG

DATE DRAWN:
4/13/2017

REV. A: UPDATE TO 2018 IBC/IRC

SCALE: NTS

DRAWING: TDI-4764-PW-NI

SHEET: 3 OF 3



2/19/2021
Lucas A. Turner, P.E.
TX PE #115094
2428 Old Natchez Trc Trl
Camden, TN 38320
Ph. 941-380-1574