

GENERAL NOTES

1. THE PRODUCT SHOWN HEREIN CONSTRUCTED FROM DECEUNINCK EXTRUDED RIGID PVC FRAMES HAS BEEN TESTED TO AAMA/WDMA/CSA 101/I.S.2/A440, AND MEETS THE REQUIREMENTS OF THE 2018 INTERNATIONAL BUILDING CODE AND INTERNATIONAL RESIDENTIAL CODE.
2. THIS PRODUCT IS NON-IMPACT RESISTANT AND REQUIRES THE USE OF IMPACT PROTECTIVE DEVICES (SHUTTERS) IN WINDBORNE DEBRIS REGIONS.
3. THE DESIGN PRESSURES INDICATED IN THIS DRAWING ARE AS LIMITED BY ASTM E-1300 GLASS TABLES, AND TESTED WATER AND STRUCTURAL PRESSURES.
4. THIS DOCUMENT ADDRESSES PRODUCT ANCHORAGE TO ACHIEVE THE INDICATED DESIGN PRESSURES AT THE INDICATED SIZES, IN THE CONFIGURATION SHOWN IN THE ELEVATIONS. INSTALL PRODUCTS WITH MAXIMUM SHIM GAP, MINIMUM EDGE DISTANCE AND EMBEDMENT, AND WITH FASTENER TYPE AS SHOWN IN THE DETAILS AND AS INDICATED IN TABLE 1. FOR FULL PRODUCT CONSTRUCTION DETAILS SEE NCTL TEST REPORTS 210-4065-01, 210-4065-01A, 210-4065-02, AND 210-4065-02A
5. MINIMUM GLAZING IS INSULATING GLASS 1/8 ANNEALED + 1/2" GED STAINLESS STEEL INTERCEPT SPACER + 1/8" ANNEALED, GLAZED WITH GE SCS2801 SILICONE BACKBEDDING W/ 1/2" GLASS BITE.
6. THE 4/3 ALLOWABLE STRESS INCREASE FACTOR (SHORT-TERM INCREASE FACTOR) HAS NOT BEEN USED IN THE ANCHOR ANALYSIS FOR THIS SYSTEM. THE 1.6 Cd FACTOR WAS USED IN THE ANALYSIS OF ANCHORAGE INTO WOOD SUBSTRATE.
7. THE OPENING SUBSTRATE MATERIALS (FRAMING, MASONRY, BUCKS) AND ATTACHMENT OF BUCKS TO THE SUBSTRATE ARE BY OTHERS AND SHALL BE VERIFIED BY THE ARCHITECT OR ENGINEER OF RECORD OR AS APPROVED BY THE AUTHORITY HAVING JURISDICTION (AHJ). BUCKING, OPENINGS, & BUCKING FASTENERS MUST BE PROPERLY DESIGNED & INSTALLED BY OTHERS TO TRANSFER SUPERIMPOSED LOADS TO THE STRUCTURE. WITH MASONRY OPENINGS, WOOD BUCKS ARE OPTIONAL.
8. DISSIMILAR MATERIALS THAT COME INTO CONTACT SHALL BE COATED OR OTHERWISE PROTECTED TO PREVENT GALVANIC REACTIONS. WOOD BUCKS, IF USED, SHALL BE PRESSURE TREATED, WITH EITHER A TREATMENT OR COATING COMPATIBLE WITH THIS PRODUCT.
9. ALL ANCHORS USED SHALL BE OF A MATERIAL OR HAVE A COATING COMPATIBLE WITH THE PRESSURE TREATED WOOD BUCKS AND ALL OTHER WINDOW MATERIALS.
10. ALL HARDWARE & FASTENERS SHALL BE IN ACCORDANCE WITH THESE DRAWINGS, OR AS APPROVED, SIGNED, AND SEALED BY A TEXAS REGISTERED PROFESSIONAL ENGINEER ON A SITE-SPECIFIC BASIS.
11. SEALING AND FLASHING STRATEGIES FOR OVERALL WATER INFILTRATION RESISTANCE OF THE INSTALLED PRODUCT SHALL BE THE RESPONSIBILITY OF OTHERS AND ARE NOT ADDRESSED BY THIS DOCUMENT.
12. FOR ADDITIONAL REQUIREMENTS SEE GENERAL ANCHOR NOTES, SHEET 3.

WINFORCE OUTSWING AWNING WINDOW, NON-IMPACT

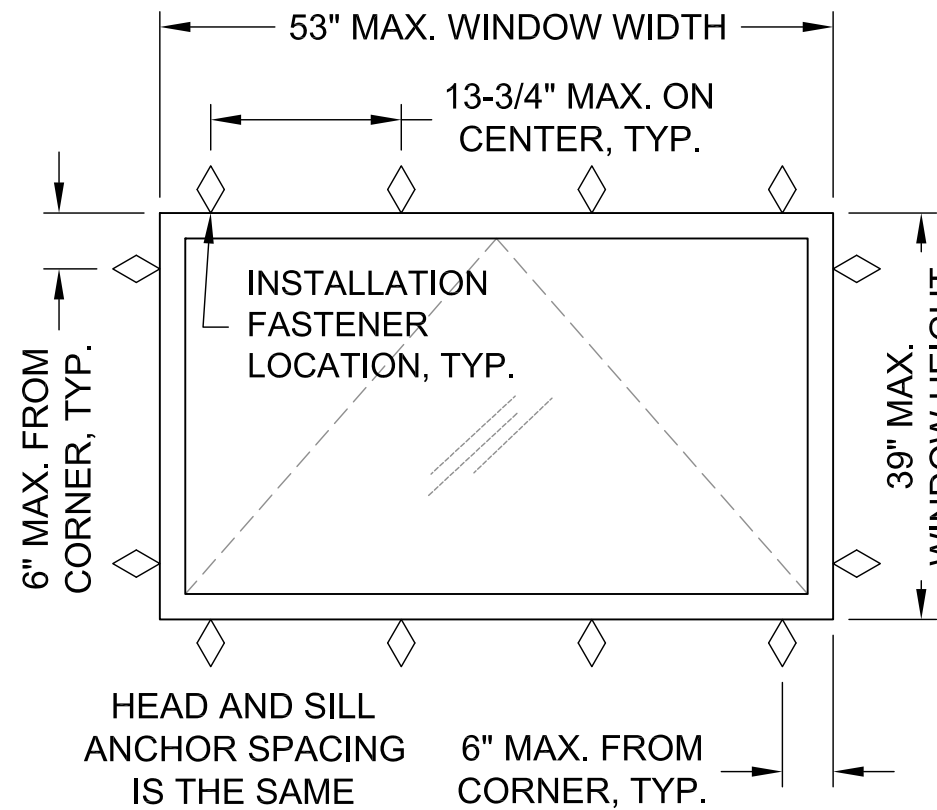

**EQUAL LEG / FLANGE ELEVATION
SEE DETAILS SHEET 2**

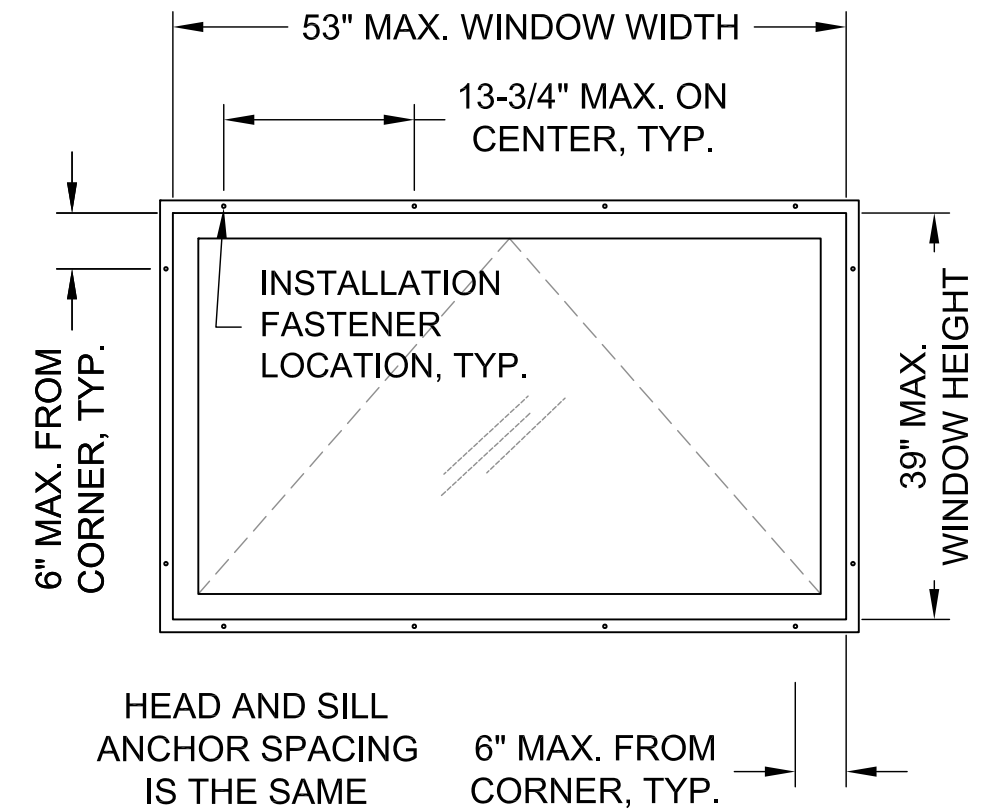

**FIN ELEVATION
SEE DETAILS SHEET 3**

DESIGN PRESSURE RATING	IMPACT RATING
+60/-60 PSF	NONE

NORTHEAST BUILDING PRODUCTS

4280 Aramingo Ave., Philadelphia, PA 19124
Ph. (215) 535-7110 www.nbpwindows.com

SHEET DESCRIPTION: NOTES, ELEVATIONS	DATE DRAWN: 4/13/2017
REV. A: UPDATE TO 2018 IBC/IRC	SCALE: NTS
DRAWING: TDI-WINFORCE-AW-NI	SHEET: 1 OF 4



2/18/2021
Lucas A. Turner, P.E.
TX PE #115094
2428 Old Natchez Trc Trl
Camden, TN 38320
Ph. 941-380-1574

WINFORCE OUTSWING AWNING WINDOW, NON-IMPACT

SEE GENERAL ANCHOR NOTES, SHEET 3.

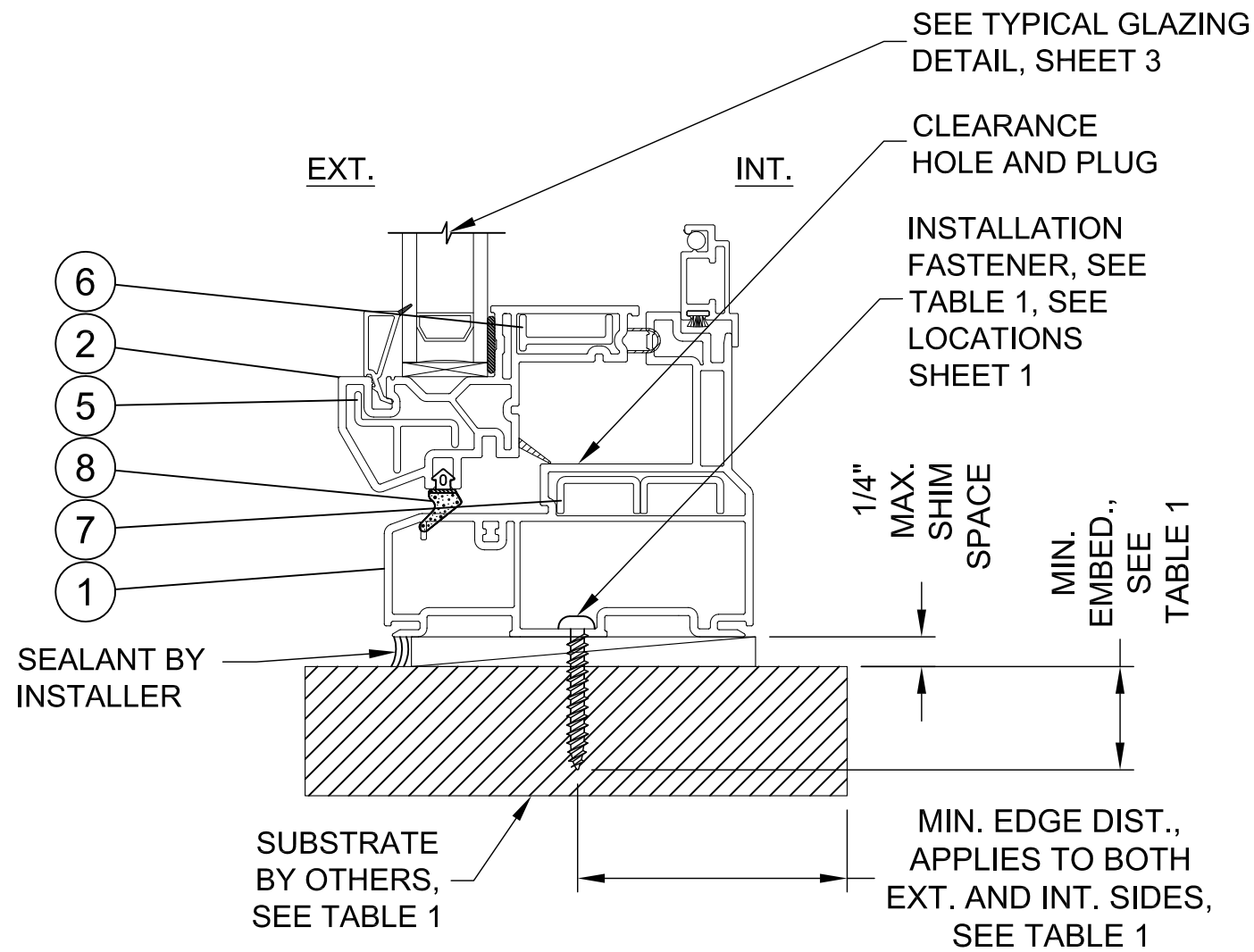

TYPICAL EQUAL LEG INSTALLATION HEAD / SILL / JAMB

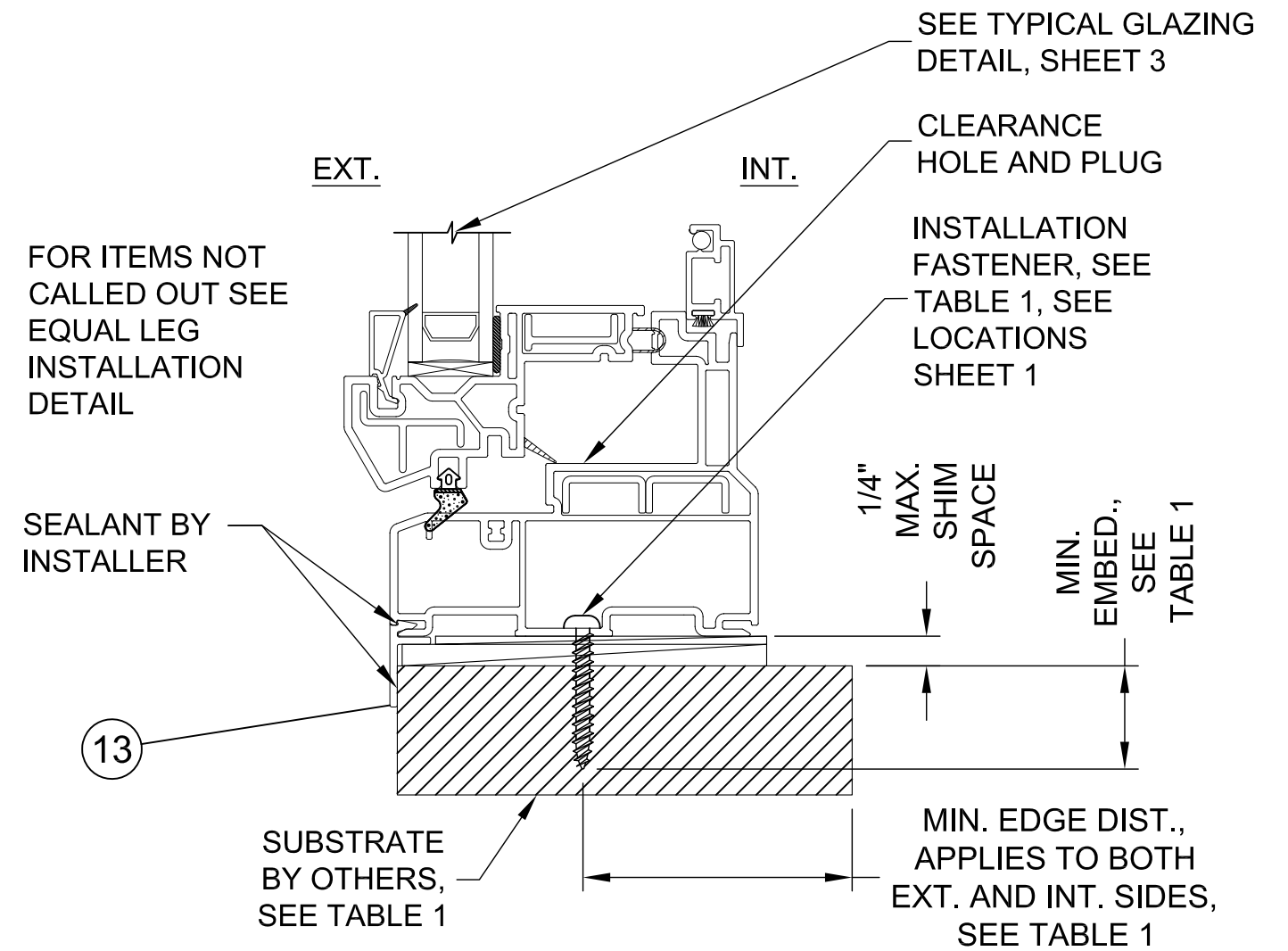

TYPICAL FLANGE INSTALLATION HEAD / SILL / JAMB

TABLE 1: EQUAL LEG / FLANGE FRAME INSTALLATION ANCHOR REQUIREMENTS TABLE
NOTE: ALL ANCHORS ARE PAN HEAD OR HEX WASHER HEAD

SUBSTRATE TYPE	ANCHOR TYPE	MIN. EMBED.	MIN. EDGE DIST.
CONCRETE (2.0 KSI MIN)	3/16" ITW TAPCON	1"	1 1/8"
HOLLOW OR GROUT-FILLED CMU (117 PCF MIN.)	3/16" ITW TAPCON	1"	2"
CONCRETE (2.85 KSI MIN.)	3/16" ELCO ULTRACON	1"	1"
2X MIN. SOUTHERN PINE WOOD (G=0.55)	#10 GRADE 5 WOOD SCREW	1-3/8"	1"
16 GAUGE (0.060") MIN. STEEL STUD, 33KSI YIELD MIN., OR 1/8" ALUM. 6063-T5 MIN.	#10-16 HILTI KWIK-FLEX OR ITW TEKS SELF-DRILLING SCREW	FULL	1/2"

NORTHEAST BUILDING PRODUCTS

4280 Aramingo Ave., Philadelphia, PA 19124
Ph. (215) 535-7110 www.nbpwindows.com

SHEET DESCRIPTION:
EQ. LEG / FLANGE INSTALLATION

DATE DRAWN:
4/13/2017

REV. A: UPDATE TO 2018 IBC/IRC

SCALE: NTS

DRAWING: TDI-WINFORCE-AW-NI

SHEET: 2 OF 4



2/18/2021
Lucas A. Turner, P.E.
TX PE #115094
2428 Old Natchez Trc Trl
Camden, TN 38320
Ph. 941-380-1574

WINFORCE OUTSWING AWNING WINDOW, NON-IMPACT

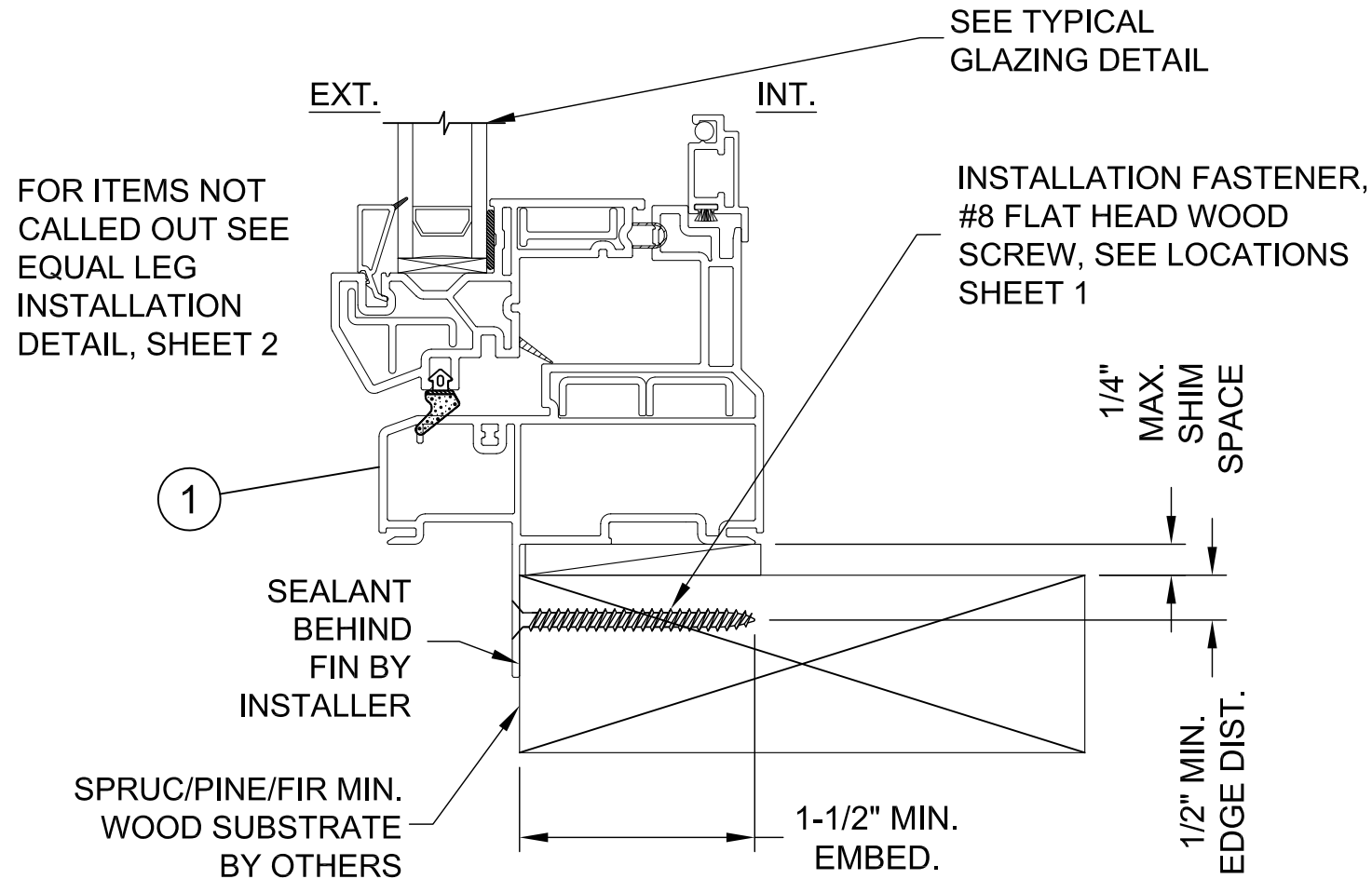

TYPICAL FIN INSTALLATION HEAD / SILL / JAMB

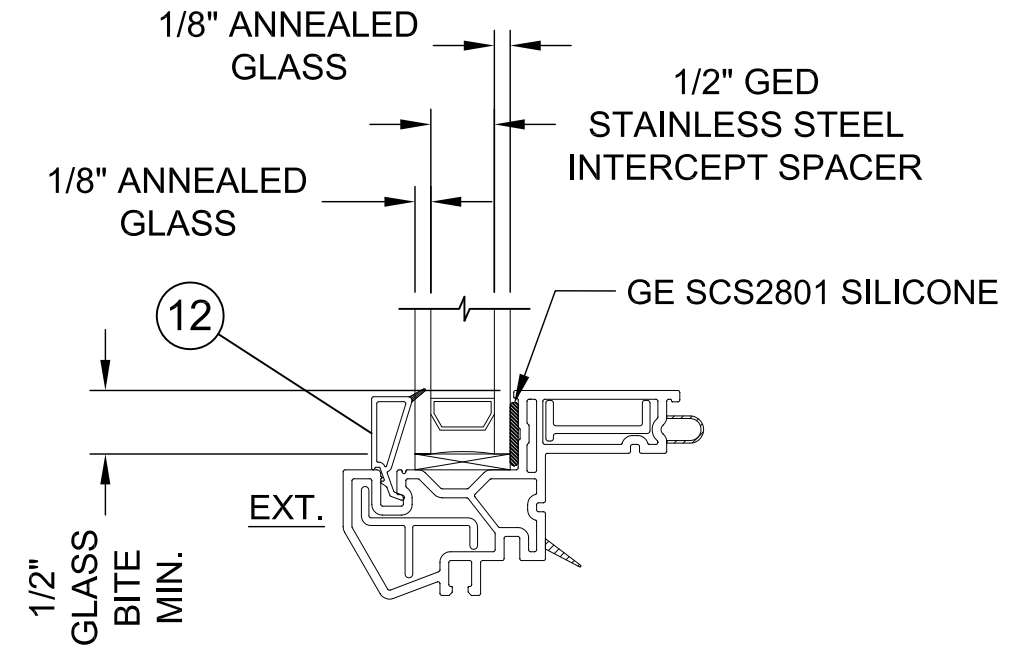

TYPICAL MIN. GLAZING DETAIL

GENERAL ANCHOR NOTES:

1. INSTALL ONE ANCHOR AS INDICATED IN DETAILS ON SHEETS 2 AND 3 AT EACH LOCATION SHOWN IN THE ELEVATIONS ON SHEET 1.
2. INSTALL SHIMS AT EACH ANCHOR LOCATION WHERE A GAP OF 1/16" OR GREATER EXISTS BETWEEN PRODUCT FRAME AND SUBSTRATE.
3. SHIMS SHALL BE LOAD-BEARING (PLASTIC OR METALLIC) AND CAPABLE OF TRANSFERRING LOADS TO SUBSTRATE.
4. SPECIFIED ANCHOR EMBEDMENT TO SUBSTRATE SHALL BE BEYOND WALL FINISH OR STUCCO, BY OTHERS. FOR ATTACHMENT TO METAL SUBSTRATES ENSURE FULL THREAD ENGAGEMENT THROUGH METAL WALL WITH MIN. 3 THREADS BEYOND.
5. FOR MASONRY WITH WOOD BUCKS LESS THAN 1-1/2" THICK, EMBEDMENT SHALL BE BEYOND WOOD BUCKS AND INTO MASONRY. WOOD BUCKS ARE OPTIONAL WITH MASONRY INSTALLATIONS WHERE MASONRY EDGE DISTANCE CONDITIONS ARE MET WITH NO BUCKS. WOOD BUCKS 1-1/2" THICK OR GREATER SHALL HAVE EMBEDMENT INTO THE WOOD BUCKS.
6. ENSURE 3" MIN. ON-CENTER SPACING BETWEEN ANY TWO INSTALLATION ANCHORS.



NORTHEAST BUILDING PRODUCTS

4280 Aramingo Ave., Philadelphia, PA 19124
Ph. (215) 535-7110 www.nbpwindows.com

SHEET DESCRIPTION: FIN INSTALLATION, TYP. GLAZING	DATE DRAWN: 4/13/2017
REV. A: UPDATE TO 2018 IBC/IRC	SCALE: NTS
DRAWING: TDI-WINFORCE-AW-NI	SHEET: 3 OF 4

2/18/2021
Lucas A. Turner, P.E.
TX PE #115094
2428 Old Natchez Trc Trl
Camden, TN 38320
Ph. 941-380-1574

BILL OF MATERIALS

ITEM NO.	DESCRIPTION	PART NO.	SOURCE	MATERIAL
1	FRAME HEAD/SILL/JAMBS	10008065 (FIN) / 10008066 (FINLESS)	DECEUNINCK	PVC
2	SASH RAILS/STILES	10005432	DECEUNINCK	PVC
3	GLAZING BEAD - 1" IG	10003196	DECEUNINCK	PVC
4	GLAZING BEAD - 3/4" IG	10005602	DECEUNINCK	PVC
5	SASH REINFORCEMENT	10500006	ASTRO SHAPES	6063-T5 ALUM.
6	SASH REINFORCEMENT	10300091	ASTRO SHAPES	6005-T5 ALUM.
7	FRAME REINFORCEMENT	10202004	ASTRO SHAPES	6063-T5 ALUM.
8	SASH SEAL	QWS-580	AMESBURY	FOAM/POLYETH.
9	SNUBBER - Frame	10300095	DECEUNINCK	6005-T5 ALUM.
10	SNUBBER - Sash	10300094	DECEUNINCK	6005-T5 ALUM.
11	SNUBBER SCREWS	#6 x 1/2" S.S. PFH	MERCHANTS	ST. STEEL
12	GLAZING BEAD - 3/4" IG	10005456	DECEUNINCK	PVC
13	ADD-ON FLANGE	10008341	DECEUNINCK	PVC
14	MAXIM DUAL ARM OPERATOR #8 X 3/4 PFH (Operator) GASKET STUD BRACKET #8 X 1 PFH (Stud Bracket) TRACK & SLIDER ASSEMBLY #8 X 3/4 PFH HANDLE KNOB S/A WASHABILITY HINGES #7 X 5/8 PFH UNDERCUT (S.S.) #8 X 1 PFH (Hinge Sash Arm) SPLINE CAP		ROTO	STEEL
15	LOCK ASSEMBLY SUPPORT PLATE #10-24 X 9/16 PPH SELF-THREAD TIE BAR GUIDE #8 X 1.25 PPH (Tie Bar Guide) KEEPER #8 X 1/2 PFH (Keeper) TIE BAR ASSEMBLY		ROTO	STEEL

WINFORCE OUTSWING AWNING WINDOW, NON-IMPACT

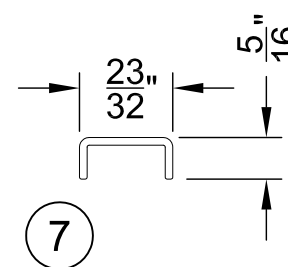
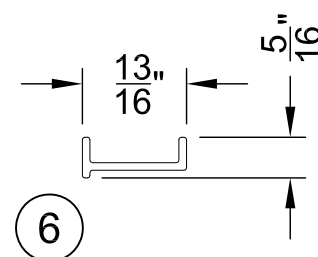
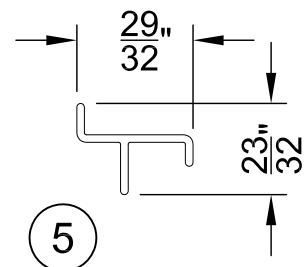
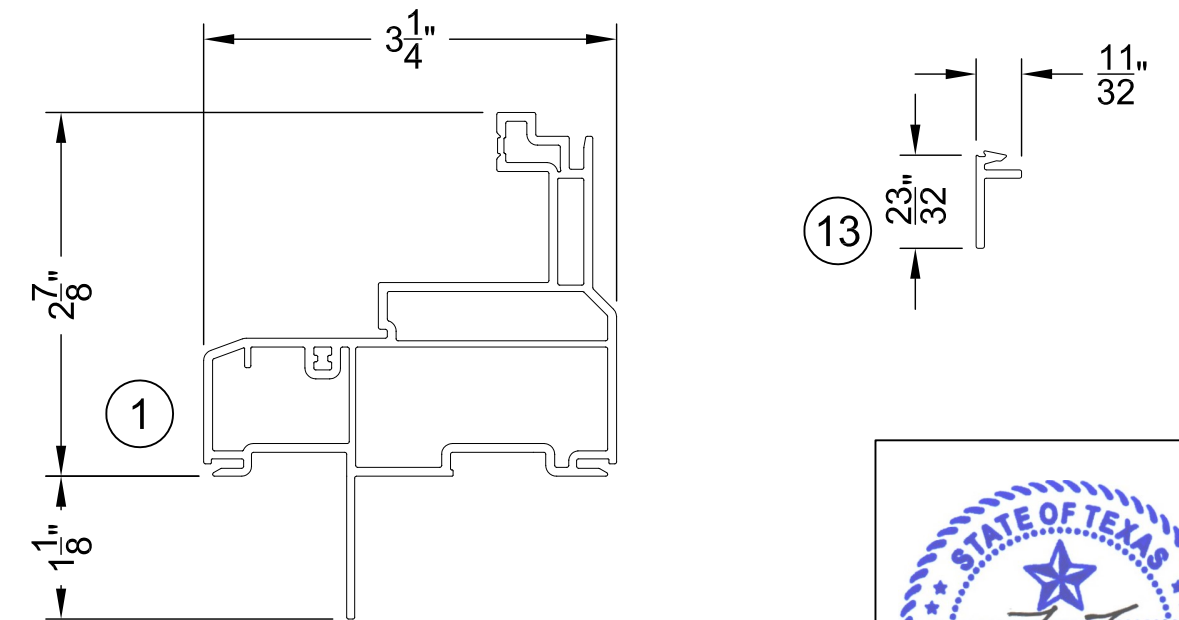
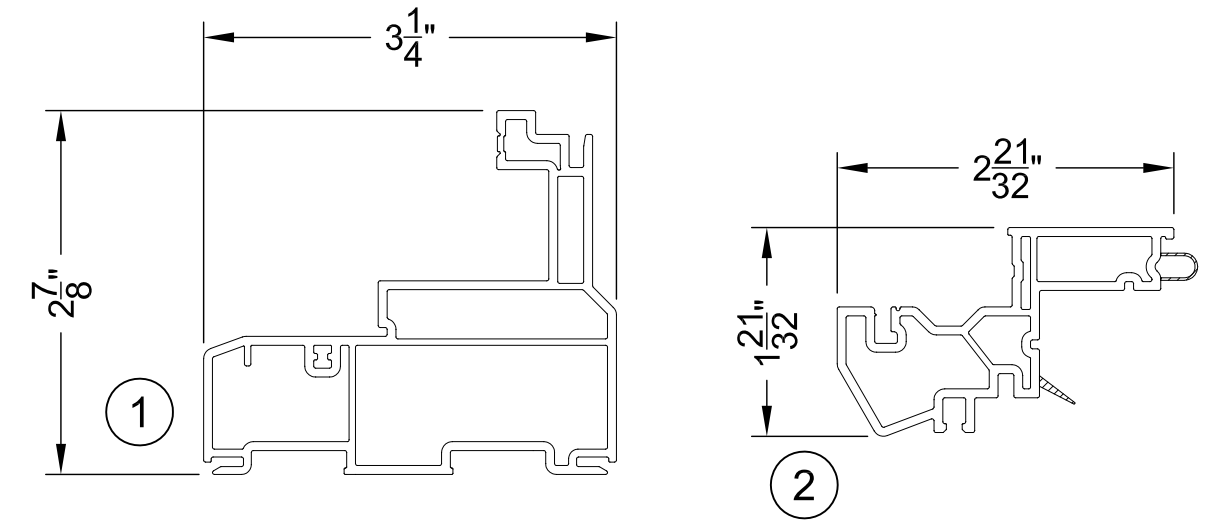

NORTHEAST BUILDING PRODUCTS

4280 Aramingo Ave., Philadelphia, PA 19124
Ph. (215) 535-7110 www.nbpwindows.com

SHEET DESCRIPTION:
BILL OF MATERIALS, PART DWGS

DATE DRAWN:
4/13/2017

REV. A: UPDATE TO 2018 IBC/IRC

SCALE: NTS

DRAWING: TDI-WINFORCE-AW-NI

SHEET: 4 OF 4



2/18/2021
Lucas A. Turner, P.E.
TX PE #115094
2428 Old Natchez Trc Trl
Camden, TN 38320
Ph. 941-380-1574