

MODEL 8200 SYSTEM 4 HORIZONTAL SLIDER - LARGE MISSILE IMPACT

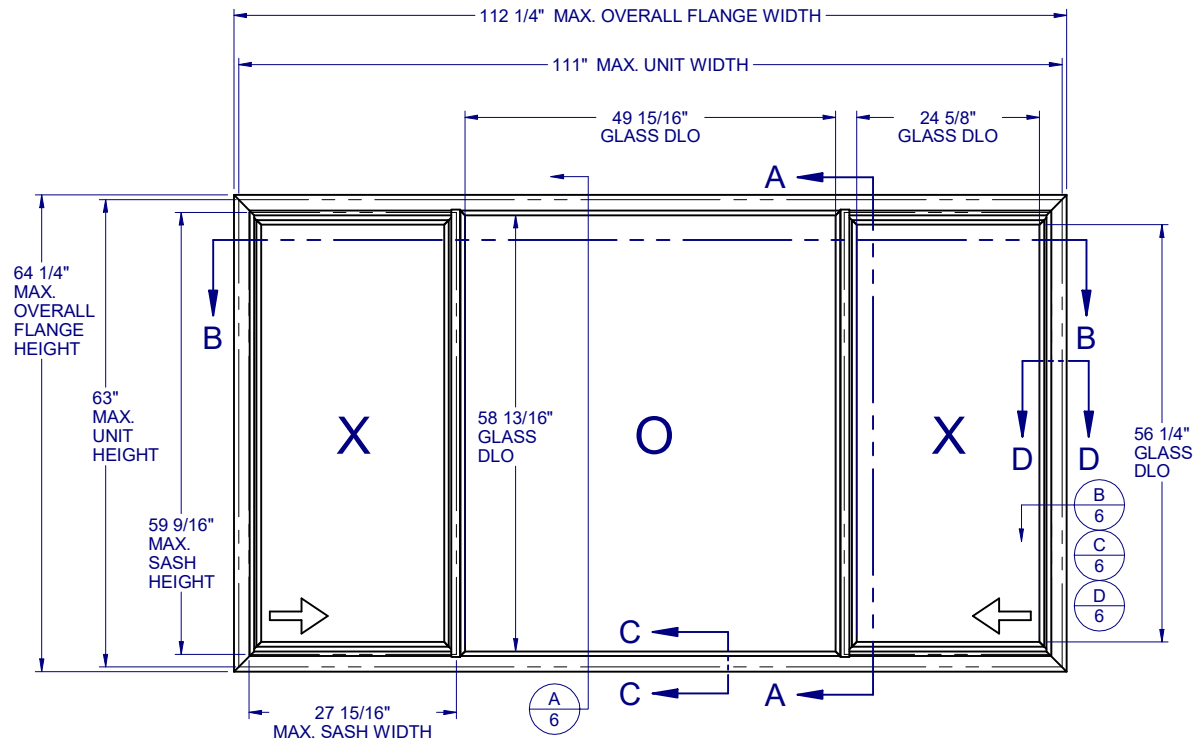

SYSTEM 4 (CAR 138-525/138-1087)
MAXIMUM ALLOWABLE DESIGN PRESSURE: +60/-60 PSF

TABLE OF CONTENTS

GENERAL NOTES & ELEVATIONS.....1
 GLAZING DETAILS.....2
 SECTION VIEWS & GLAZING DETAILS.....3
 EXTRUSIONS & B.O.M.....4
 ANCHOR SCHEDULE & NOTES.....5
 INSTALLATION DETAILS.....6

GENERAL NOTES:

1. THE PRODUCT SHOWN HEREIN IS DESIGNED AND MANUFACTURED TO COMPLY WITH THE REQUIREMENTS OF THE 2018 INTERNATIONAL BUILDING CODE (IBC) AND 2018 INTERNATIONAL RESIDENTIAL CODE (IRC).
2. GLAZING OPTIONS: (SEE SHEET 2)
3. CONFIGURATIONS: "XOX".
4. ANCHORAGE: THE 33 1/3% STRESS INCREASE HAS NOT BEEN USED IN THE DESIGN OF THIS PRODUCT. SEE SHEET 6 FOR ANCHOR DETAILS. WINDLOAD DURATION FACTOR Cd=1.6 WAS USED FOR WOOD ANCHOR CALCULATIONS.
5. PRODUCT APPROVED FOR IMPACT RESISTANCE. SHUTTERS ARE NOT REQUIRED. THE IMPACT ROTARY LOCKS ARE INTENDED TO BE LEFT UNLATCHED DURING NORMAL OPERATION OF THIS PRODUCT, BUT MUST BE ENGAGED PRIOR TO EXPOSURE TO HURRICANE WINDS AND FLYING DEBRIS.
6. ALL FRAMES AND VENTS FULLY WELDED. SMALL JOINT SEAM SEALANT USED AT FIXED MEETING RAIL AND HEAD/SILL.
7. SERIES / MODEL DESIGNATION HS-8200.
8. THE DESIGNATION X AND O STAND FOR THE FOLLOWING:
X = OPERABLE SASH, O = FIXED SASH
9. SECTION CALLOUTS APPLY TO ALL ELEVATIONS IN A SIMILAR LOCATION.
10. EXTERNAL WEEP SLOT = 1/4" x 1" LOCATED 4" FROM BOTH ENDS.



1900 SW 44TH AVE.
 Ocala, Florida 34474
 WWW.CWS.CC

8200 PVC HORZ. SLIDER IMPACT

NO.	DESCRIPTION:	BY:	DATE:	
				REVISIONS
B	IBC/IRC REF. 2018 UPDATE	JLD	05/08/20	
A	REVISED TO TDI REQUEST	JML	3/27/17	

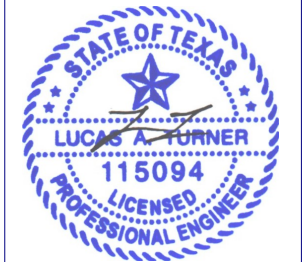

5/28/2020

LUCAS A. TURNER, P.E.
 TX PE # 115094
 TBPE REG. #F-18075
 2428 OLD NATCHEZ TRC TRL
 CAMDEN, TN 38320
 PH. 941-380-1574

SHEET DESCRIPTION:

GENERAL NOTES AND ELEVATIONS

DRAWN BY: EMK	DATE: 11/12/15
DWG #: TDI-869	REV.: B
SCALE: 1:20	SHEET 1 OF 6

**8200 PVC
HORZ. SLIDER
IMPACT**

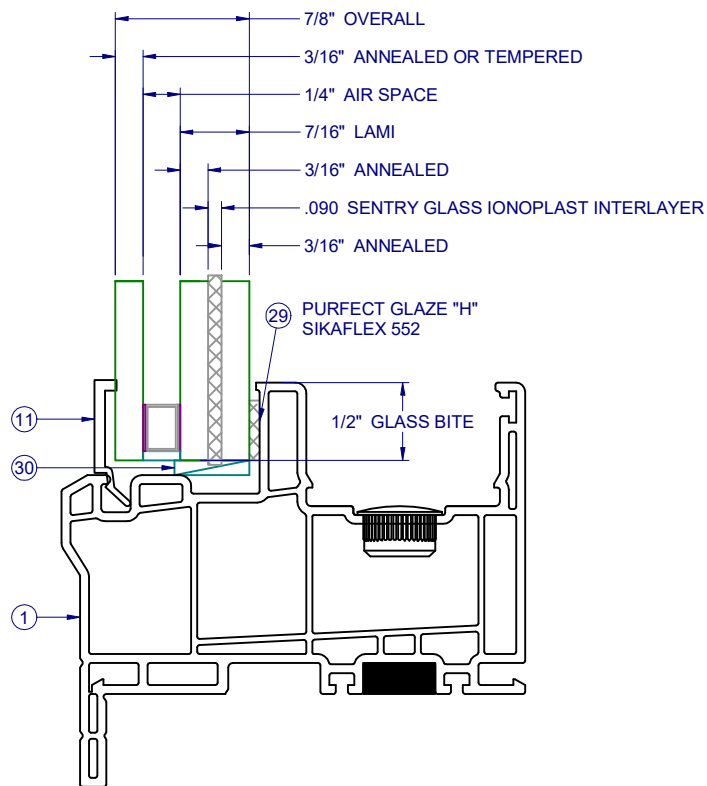

SYSTEM 4
FIXED GLASS

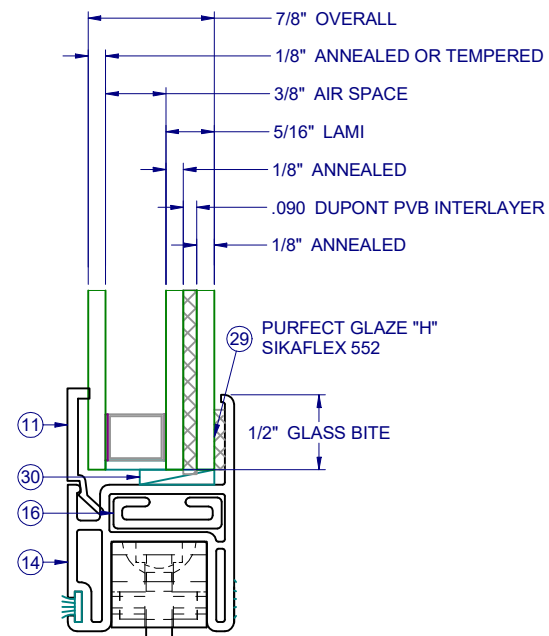

SYSTEM 4
SASH GLASS

NO.	DESCRIPTION:	BY:	DATE:
B	IBC/IRC REF. 2018 UPDATE	JLD	05/08/20
A	REVISED TO TDI REQUEST	JML	3/27/17

REVISIONS



5/28/2020

LUCAS A. TURNER, P.E.
TX PE # 115094
TBPE REG. #F-18075
2428 OLD NATCHEZ TRC TRL
CAMDEN, TN 38320
PH. 941-380-1574

SHEET DESCRIPTION:

GLAZING DETAILS

DRAWN BY: EMK	DATE: 11/12/15
DWG #: TDI-869	REV.: B
SCALE: 1:1	SHEET 2 OF 6

**8200 PVC
HORZ. SLIDER
IMPACT**

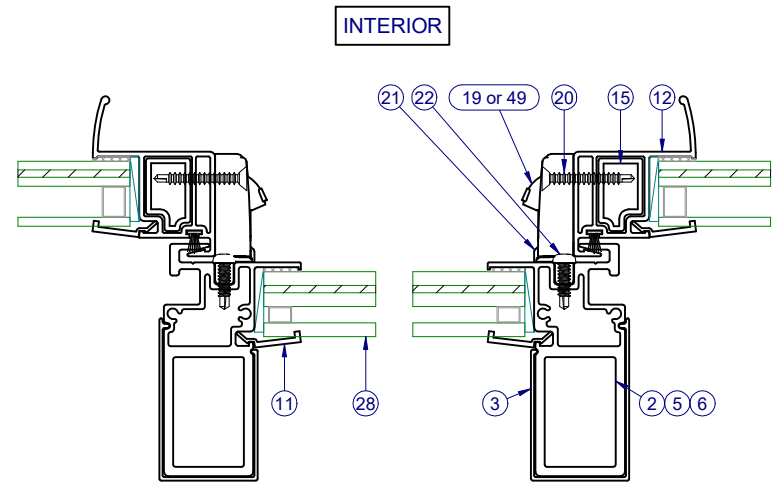
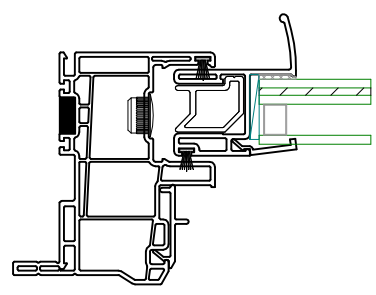

SECTION VIEW B-B

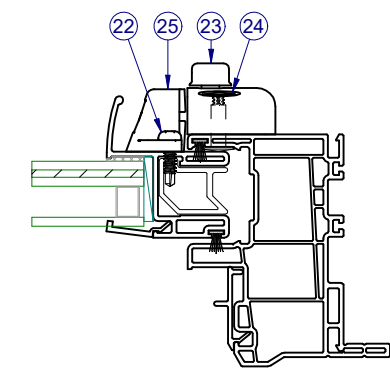
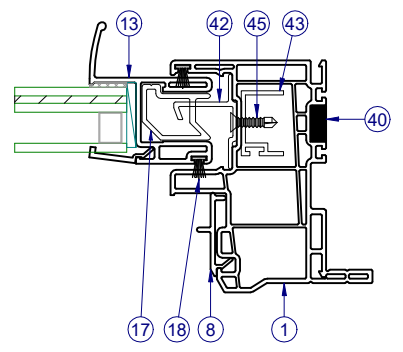

SECTION VIEW D-D
JAMB ROTARY LOCKS

JAMB ROTARY LOCKS:
- MAY BE SUBSTITUTED FOR JAMB
IMPACT LOCKS ON FLANGE UNITS.
- REQUIRED ON FIN UNITS.

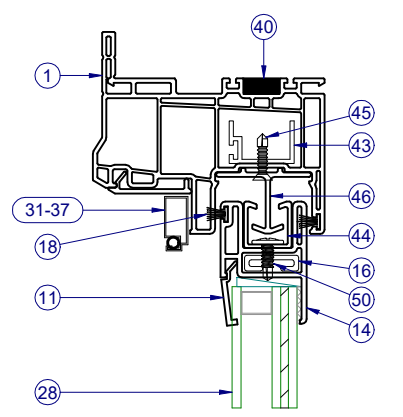

SECTION VIEW A-A

INTERIOR

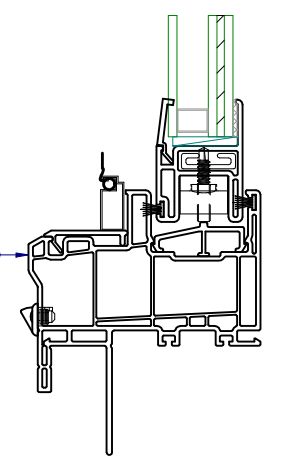
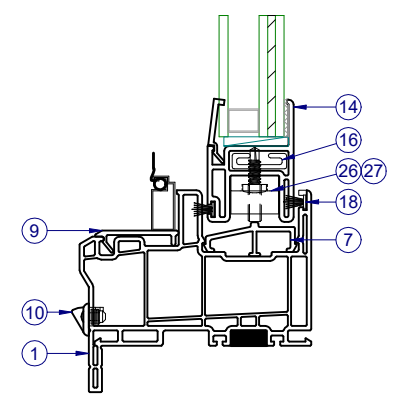

SECTION VIEW C-C
ALTERNATE FIN FRAME

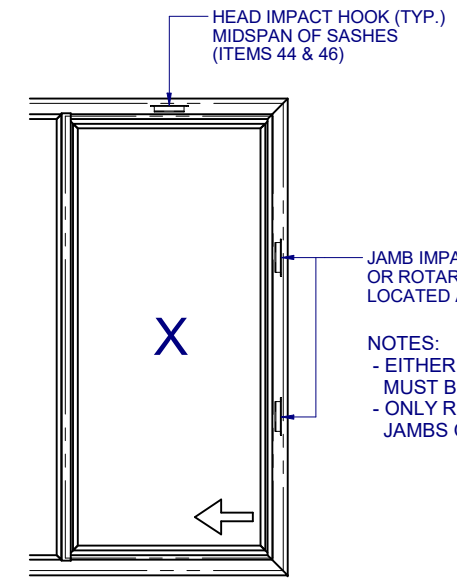

HEAD IMPACT HOOK AND
JAMB IMPACT HOOK/ROTARY LOCK LOCATIONS
1:20

JAMB IMPACT HOOKS (ITEM 42)
OR ROTARY LOCKS (ITEM 23)
LOCATED AT THIRD POINTS.

NOTES:
- EITHER IMPACT HOOKS OR ROTARY LOCKS
MUST BE USED IN BOTH JAMBS OF FLANGE UNITS.
- ONLY ROTARY LOCKS MUST BE USED IN BOTH
JAMBS OF FIN UNITS.

NO.		DESCRIPTION:	BY:	DATE:
B	05/08/20	IBC/IRC REF. 2018 UPDATE	JLD	
A	3/27/17	REVISED TO TDI REQUEST	JML	

REVISIONS



5/28/2020

LUCAS A. TURNER, P.E.
TX PE # 115094
TBPE REG. #F-18075
2428 OLD NATCHEZ TRC TRL
CAMDEN, TN 38320
PH. 941-380-1574

SHEET DESCRIPTION:

SECTION VIEWS

DRAWN BY:	DATE:
EMK	11/12/15
DWG #:	REV.:
TDI-869	B
SCALE:	SHEET
1:2	3 OF 6

**8200 PVC
HORZ. SLIDER
IMPACT**

NO.	DESCRIPTION:	BY:	DATE:
B	IBC/IRC REF. 2018 UPDATE	JLD	05/08/20
A	REVISED TO TDI REQUEST	JML	3/27/17

REVISIONS



5/28/2020

LUCAS A. TURNER, P.E.
TX PE # 115094
TBPE REG. #F-18075
2428 OLD NATCHEZ TRC TRL
CAMDEN, TN 38320
PH. 941-380-1574

SHEET DESCRIPTION:
ANCHOR SCHEDULE AND NOTES

DRAWN BY: EMK	DATE: 11/12/15
DWG #: TDI-869	REV.: B
SCALE: 1:25	SHEET 5 OF 6

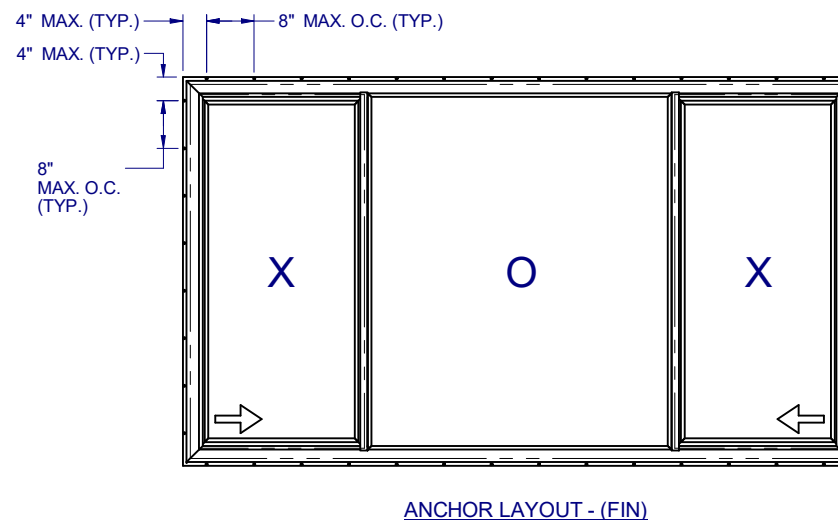
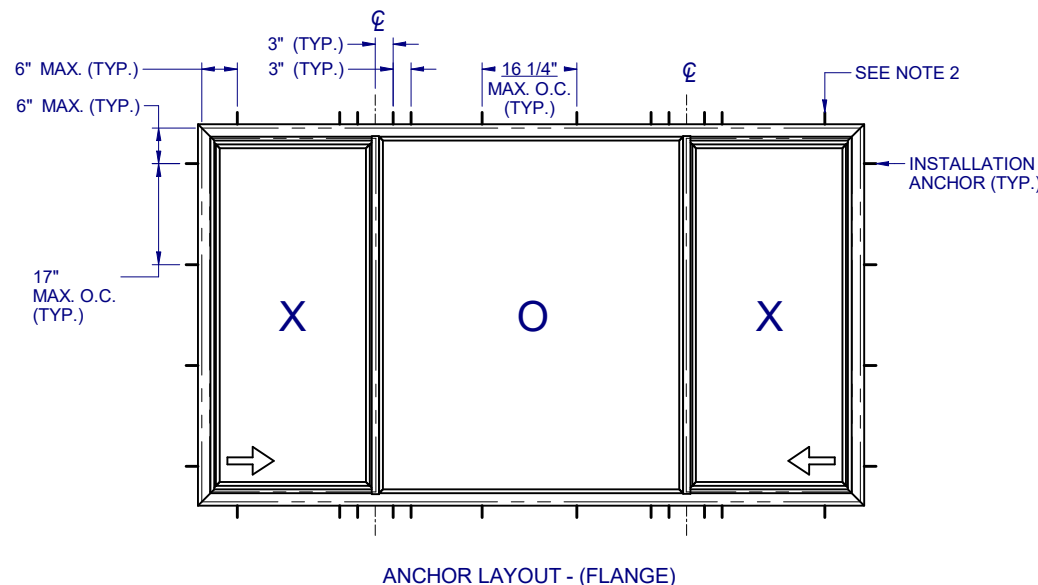

NOTES:

- INSTALL ONE ANCHOR AT EACH INSTALLATION LOCATION. SILL ANCHOR SPACING SAME AS HEAD.
- SHIM AS REQ AT EACH INSTALLATION ANCHOR USING LOAD BEARING SHIMS. MAX. ALLOWABLE SHIM STACK TO BE 1/4". USE SHIMS WHERE SPACE GREATER THAN 1/16" IS PRESENT. LOAD BEARING SHIMS SHALL BE CONSTRUCTED OF HIGH DENSITY PLASTIC OR BETTER. WOOD SHIMS ARE NOT ALLOWED.
- ANCHOR TYPE, SIZE, SPACING AND EMBEDMENT SHALL BE AS SPECIFIED IN THESE DRAWINGS, SEE TABLE 1, SHEET 6.
- ALL INSTALLATION ANCHORS MUST BE MADE OF OR PROTECTED WITH A CORROSION RESISTANT MATERIAL OR COATING. DISSIMILAR METALS OR MATERIALS IN CONTACT WITH PRESSURE TREATED WOOD MUST BE PROTECTED TO PREVENT REACTION.
- INSTALLATION ANCHORS SHALL BE IN ACCORDANCE WITH ANCHOR MANUFACTURER'S INSTALLATION INSTRUCTIONS, AND ANCHORS SHALL NOT BE USED IN SUBSTRATES WITH STRENGTHS LESS THAN THE MINIMUM SPECIFIED IN TABLE 1, SHEET 6.
- ANCHOR EMBEDMENT TO SUBSTRATE SHALL BE BEYOND WALL DRESSING OR STUCCO. FOR CONCRETE/CMU OPENINGS, EMBEDMENT SHALL BE BEYOND WOOD BUCKS, IF USED, INTO SUBSTRATE. INSTALLATIONS TO SOLID CONCRETE OR GROUT-FILLED CMU MAY INCLUDE BUT DO NOT REQUIRE 1X WOOD BUCKS BETWEEN THE PRODUCT AND SUBSTRATE. INSTALLATIONS TO HOLLOW CMU REQUIRE THE USE OF 1X BUCKS BETWEEN THE PRODUCT AND SUBSTRATE.
- A MINIMUM CENTER-TO-CENTER SPACING SHALL BE MAINTAINED BETWEEN ALL FASTENERS: 3" FOR MASONRY, 1" FOR WOOD AND METAL.
- WOOD OR MASONRY OPENINGS, BUCKS AND BUCK FASTENERS SHALL BE PROPERLY DESIGNED BY THE ARCHITECT OR ENGINEER OF RECORD AND INSTALLED TO TRANSFER WIND LOADS TO THE STRUCTURE. SUBSTRATES SHALL MEET THE MINIMUM STRENGTH REQUIREMENTS AS SHOWN IN TABLE 1, SHEET 6. CONCRETE AND MASONRY SUBSTRATES MAY NOT BE CRACKED.
- SEALING AND FLASHING STRATEGIES FOR OVERALL WATER RESISTANCE OF INSTALLATION SHALL BE DONE BY OTHERS FOLLOWING THE CURRENT VERSION OF THE REFERENCE DOCUMENTS:
FMA/AAMA 100(FIN WINDOWS), FMA/AAMA 200(FLANGE WINDOWS), FMA/WDMA 250(BOX WINDOWS), FMA/AAMA/WDMA 300(EXTERIOR DOORS)

