

GENERAL NOTES:

- ALL FASTENERS SHALL BE IN ACCORDANCE WITH THESE DRAWINGS. SPECIFIED ANCHOR EMBED TO BASE MATERIAL SHALL BE BEYOND WALL FINISH OR STUCCO.
- OPENINGS, BUCKING & BUCKING FASTENERS MUST BE PROPERLY DESIGNED & INSTALLED TO TRANSFER WIND LOADS TO THE STRUCTURE.
- THESE NON-IMPACT RATED PRODUCT INSTALLATIONS ARE IN ACCORDANCE WITH AND MEET THE REQUIREMENTS OF THE INTERNATIONAL BUILDING CODE (IBC).
- ALL ANCHORS SECURING PRODUCT FRAME TO PRESSURE TREATED BUCKS OR WOOD FRAMING SHALL BE CAPABLE OF RESISTING CORROSION CAUSED BY THE PRESSURE TREATING CHEMICALS IN THE WOOD.
- TO THE BEST OF OUR KNOWLEDGE, THE PRODUCT SHOWN HEREIN IS CERTIFIED & QUALITY ASSURED BY A NATIONALLY ACCREDITED CERTIFICATION/DA ENTITY & SHALL BE LABELED IN ACCORDANCE WITH CERTIFICATION/DA ENTITIES SPECIFICATIONS. PRODUCT ASSEMBLY IS NOT PART OF THIS DRAWING AND SHALL BE IN ACCORDANCE WITH THE MANUFACTURER'S QUALITY ASSURANCE SPECIFICATIONS & TESTING REPORTS.
- CERTIFICATION OF THESE PRODUCT INSTALLATIONS SHALL BE CONSIDERED VOID IF ANY OF THE FOLLOWING APPLY: 1) THEY ARE INSTALLED WITHOUT A BUILDING PERMIT FROM THE APPLICABLE LOCAL BUILDING DEPARTMENT. 2) IF THEY ARE INSTALLED BY ANYONE OTHER THAN A LICENSED CONTRACTOR EXPERIENCED WITH WINDOW/DOOR INSTALLATIONS. 3) IF CHANGES HAVE OCCURRED TO THE PRODUCT'S CERTIFICATION ENTITY'S CERTIFICATE THAT CAUSE THESE INSTALLATIONS TO BE INCORRECT OR INCONSISTENT WITH WHAT HAS BEEN TESTED.
- THE LEAST DESIGN PRESSURE SPECIFIED EITHER IN THIS DRAWING OR IN THE PRODUCTS CERTIFICATION SHALL CONTROL FOR THE INSTALLED PRODUCT.
- THESE DRAWINGS CERTIFY THE PRODUCT INSTALLATION ONLY. WATER PROOFING OF THE INSTALLED PRODUCT IS NOT PART OF THIS INSTALLATION CERTIFICATION. THAT RESPONSIBILITY SHALL BE THAT OF THE MANUFACTURER &/OR INSTALLER.

ALLOWABLE DESIGN PRESSURE		
MAX. FRAME WIDTH (IN.)	MAX. FRAME HEIGHT (IN.)	ALLOWABLE PRESSURE (+/- PSF)
35	73	40
25	73	50
35	59	50

PRESSURE SHOWN IN THIS TABLE IS FOR INSTALLATION CONDITIONS ONLY. THE GOVERNING DESIGN PRESSURE ON THE WINDOWS SHALL BE THE LESSER OF THAT SHOWN IN THE INDIVIDUAL WINDOW'S TDI APPROVAL OR THAT SHOWN IN THIS TABLE.

FRAME ANCHOR REQUIREMENTS TABLE

OPENING TYPE (SUBSTRATE)	FRAME/CLIP/NAIL FIN TO OPENING FASTENER TYPE	MINIMUM EMBED	MINIMUM EDGE DIST.
FRAME SCREWS			
MIN. 2X4 WOOD FRAME OR BUCK (MIN. GR. 3 & G=0.55)	NO. 10 SMS OR WOOD SCREW	1 1/4"	3/4"
MIN. 18 GA. 33 KSI METAL STUD	NO. 10 GR. 5 SELF TAP/DRILL SCREW	FULL	1/2"
MIN. 1/8" THK A36 STEEL	NO. 10 GR. 5 SELF TAP/DRILL SCREW	FULL	1/2"
MIN. 1/8" THK 6063-T5 ALUM.	NO. 10 GR. 5 SELF TAP/DRILL SCREW	FULL	1/2"
C-90 CMU/2500 PSI CONCRETE	(1) 1/4" CONCRETE SCREW	1 1/4"	2"
(2) INSTALLATION CLIP SCREWS (STANDARD BENT CONDITION)			
MIN. 2X4 WOOD FRAME OR BUCK (MIN. GR. 3 & G=0.55)	NO. 8 X 1 1/2" SMS	1 3/8"	(2) N/A
MIN. 1/8" THK A36 STEEL	NO. 8 GR. 5 SELF TAP/DRILL SCREW	FULL	(2) N/A
MIN. 1/8" THK 6063-T5 ALUM.	NO. 8 GR. 5 SELF TAP/DRILL SCREW	FULL	(2) N/A
INSTALLATION CLIP SCREWS (ALTERNATE STRAIGHT CONDITION)			
MIN. 2X6 WOOD FRAME OR BUCK (MIN. GR. 3 & G=0.55)	NO. 8 X 1 1/2" SMS	1 3/8"	3/4"
MIN. 18 GA. 33 KSI METAL STUD	NO. 8 GR. 5 SELF TAP/DRILL SCREW	FULL	1/2"
MIN. 1/8" THK A36 STEEL	NO. 8 GR. 5 SELF TAP/DRILL SCREW	FULL	1/2"
MIN. 1/8" THK 6063-T5 ALUM.	NO. 8 GR. 5 SELF TAP/DRILL SCREW	FULL	1/2"
(3) NAILING FIN FASTENERS			
MIN. 2X4 WOOD FRAME OR BUCK (MIN. GR. 3 & G=0.55)	NO. 8 X 1 1/2" SMS	1 3/8"	1/2"
MIN. 2X4 WOOD FRAME OR BUCK (MIN. GR. 3 & G=0.55)	11 GA. ROOFING NAIL	1 3/8"	1/2"
MIN. 1/8" THK A36 STEEL	NO. 8 GR. 5 SELF TAP/DRILL SCREW	FULL	1/2"
MIN. 1/8" THK 6063-T5 ALUM.	NO. 8 GR. 5 SELF TAP/DRILL SCREW	FULL	1/2"

- CONCRETE SCREWS SHALL BE ELCO ULTRACONS (C.S.), ELCO CRETE-FLEX (S.S.), ITW RAMSET/RED HEAD TAPCONS (C.S. OR S.S.) OR HILTI KWIK-CON II (C.S. OR S.S.).
- STANDARD BENT CLIP INSTALLATION SCREWS SHALL BE POSITIONED WITHIN 1/4" OF THE BUCK/SUBSTRATE EDGE AND, IF INTO WOOD, ANGLED 20 TO 30 DEGREES INTO THE BUCK.
- WHEN SCREWS ARE USED WITH THE NAIL FIN, THEY MUST BE A WAFFLE HEAD SCREW OR HAVE A FLAT WASHER AT THE SCREW HEAD.

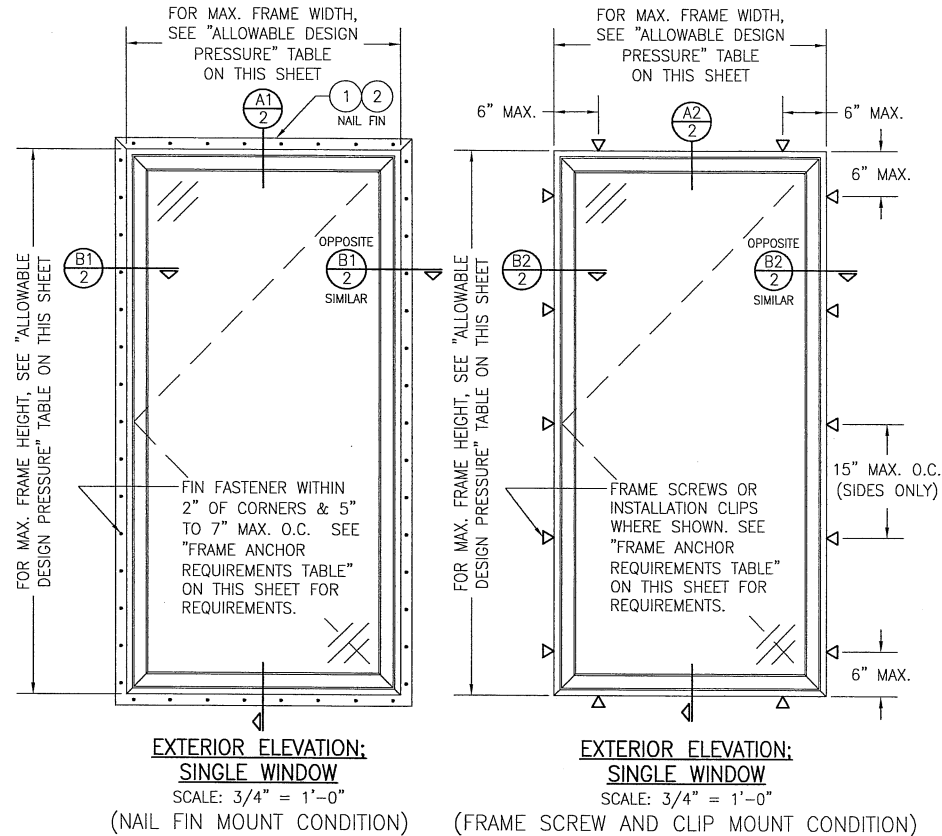

EDGE DISTANCE MAY BE DECREASED TO 1/2" IF SCREWS ARE ANGLED 15 TO 20 DEGREES AWAY FROM THE EDGE.

ALTERNATE ANCHOR/SUBSTRATE EVALUATION NOTE:
ALL ALTERNATE ANCHORS IN THEIR SPECIFIED SUBSTRATES HAVE BEEN ANALYZED IN ACCORDANCE WITH THEIR APPLICABLE STANDARD(S) AND ARE FOUND TO BE EQUIVALENT TO OR STRONGER THAN THE ANCHOR(S) USED IN TESTING WITH THIS PRODUCT.

CONDITIONS SHOWN ON THIS DRAWING ARE GOVERNED BY INSTALLATION REQUIREMENTS ONLY. THE GOVERNING CONDITIONS ON ANY SPECIFIC PRODUCT SHALL BE THE LESSER OF THOSE SPECIFIED IN THE PRODUCTS TDI APPROVAL OR THAT SHOWN IN THESE DRAWINGS.

INSTALLATION EVALUATION IS BASED ON APPLICABLE ANCHOR STANDARDS AND/OR INFORMATION & RESULTS FROM APPLICABLE TEST REPORTS. THE BUILDING CODE VERSION CONSIDERED WITH THE EVALUATION WAS THAT IN FORCE AT THE TIME OF THE EVALUATION. IN THE EVENT OF CODE VERSION CHANGES/UPDATES OR IN THE EVENT THAT NEW OR ADDITIONAL TESTING IS COMPLETED ON THE REFERENCED PRODUCT, PRIOR TO STATING CODE COMPLIANCE, THE MANUFACTURER SHALL CONFIRM WITH THE INSTALLATION EVALUATION ENGINEER OF RECORD THAT THE INSTALLATIONS SPECIFIED HERE-IN ARE CURRENT WITH THE THEN CURRENT TESTING, CODE AND APPLICABLE STANDARDS.

THESE DRAWINGS ARE APPLICABLE ONLY TO THE PRODUCT SPECIFIED. THEY MAY NOT BE USED FOR THE ASSEMBLY AND/OR INSTALLATION OF ANY OTHER PRODUCT NOR MAY THEY BE USED FOR RATIONAL AND/OR LOCAL APPROVAL OF ANY PRODUCT NOT PRODUCED BY THE MANUFACTURER STATED ON THESE DRAWINGS.

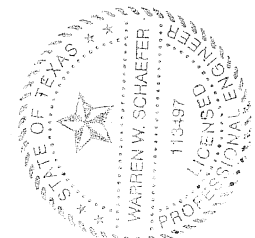

DRAWN BY: W.W.S.	CHECKED BY: W.W.S.
PLOT: 1-16	DATE: 06/08/16
DATE	
BY	
NO.	REVISION DESCRIPTION
ARTCHITECT SERIES CONTEMPORARY NON-IMPACT CASEMENT WINDOWS JOB INFORMATION: PELLA CORPORATION 102 MAIN STREET PELLA, IA 50219 641-621-1000 	
CONSULTANTS: W. W. SCHAEFER ENGINEERING & CONSULTING, P.A. (REG. NO. F-14960) 7480 150TH COURT NORTH, SUITE 110 PALM BEACH GARDENS, FL 33418 PHONE: 561-744-3424	
CERTIFICATION JUN 08 2016 WARREN W. SCHAEFER, P.E. P.E. NO. 113497	
DRAWING NO. 1920T	REV.
SHEET NO. 1	OF 3

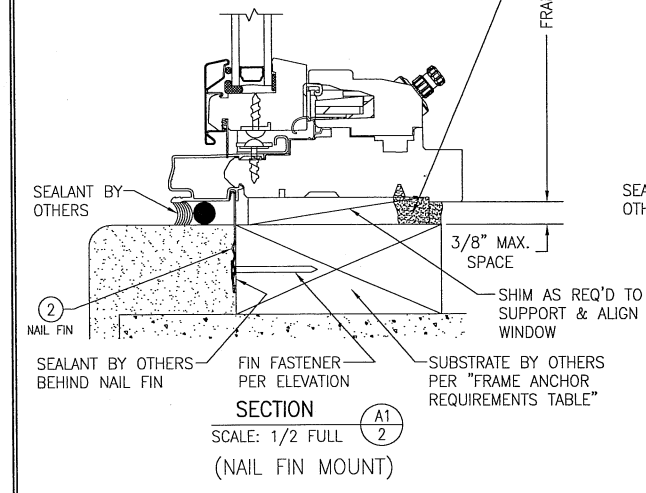
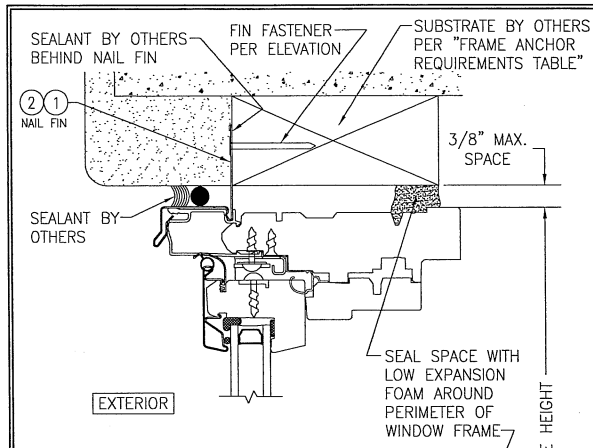

SECTION A1
SCALE: 1/2 FULL
(NAIL FIN MOUNT)

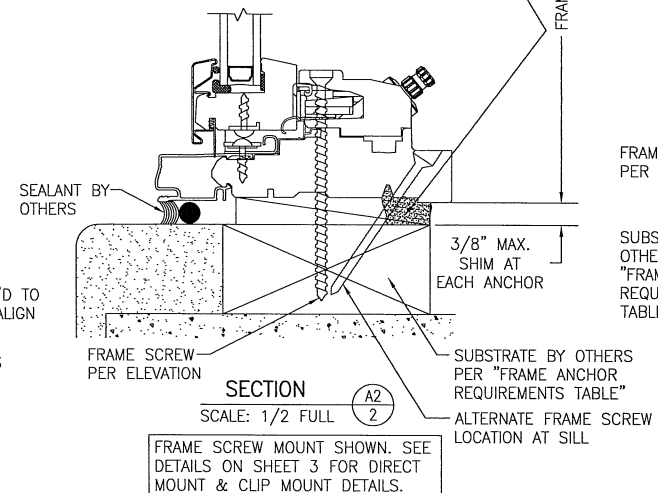
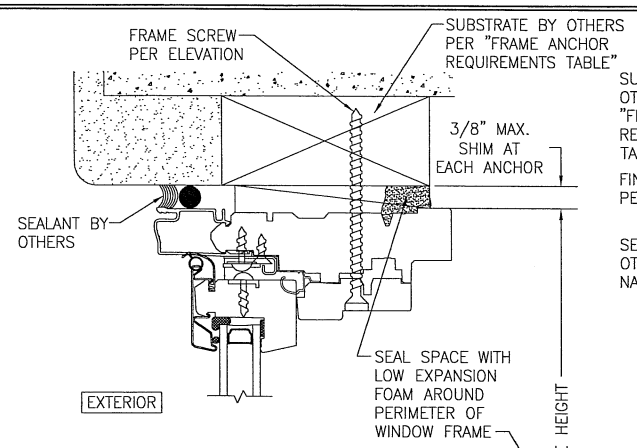

SECTION A2
SCALE: 1/2 FULL
FRAME SCREW MOUNT SHOWN. SEE DETAILS ON SHEET 3 FOR DIRECT MOUNT & CLIP MOUNT DETAILS.

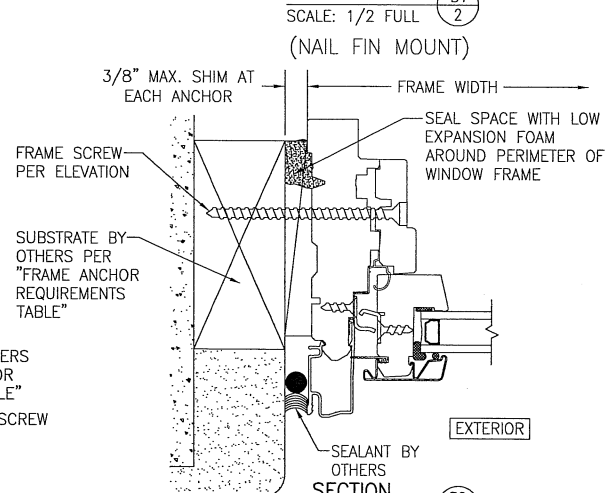
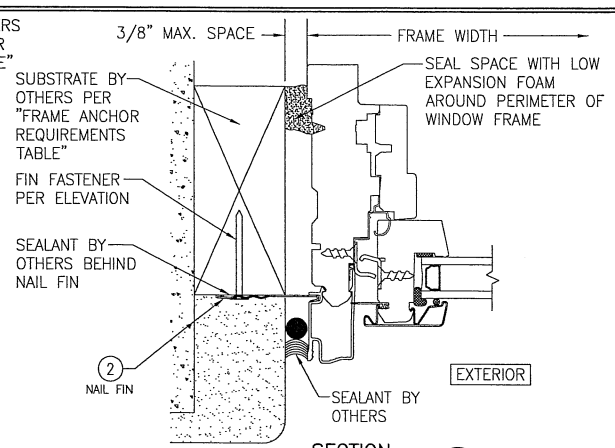

SECTION B2
SCALE: 1/2 FULL
FRAME SCREW MOUNT SHOWN. SEE DETAILS ON SHEET 3 FOR DIRECT MOUNT & CLIP MOUNT DETAILS.

DRAWN BY: W.W.S.	CHECKED BY: W.W.S.
PLT: 1=2	DATE: 06/08/16
DATE:	
BY:	
REVISION DESCRIPTION:	
NO.	

ARTCHITECT SERIES CONTEMPORARY NON-IMPACT CASEMENT WINDOWS
PELLA CORPORATION
 102 MAIN STREET
 PELLA, IA 50219
 641-621-1000



CONSULTANTS
W. W. SCHAEFER ENGINEERING & CONSULTING, P.A. (REG. NO. F-14980)
 7480 150TH COURT NORTH
 PALM BEACH GARDENS, FL 33418
 PHONE: 561-744-3624

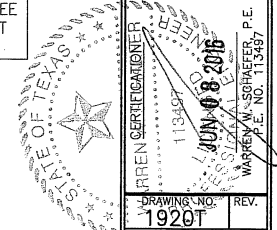

DRAWING NO. 1920T	REV.
SHEET NO. 2	OF 3

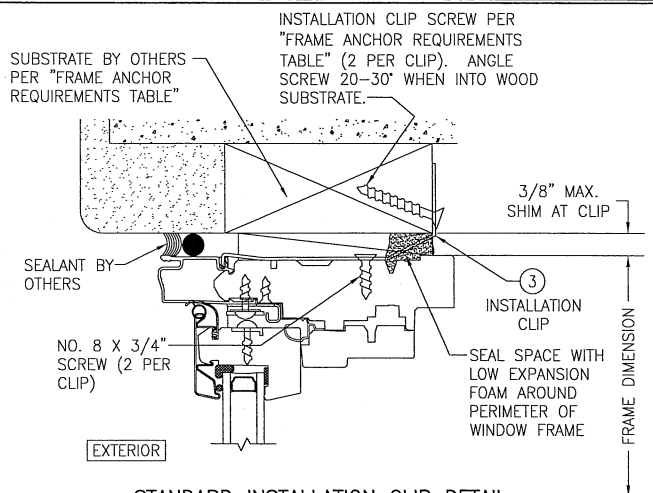

STANDARD INSTALLATION CLIP DETAIL
 (HEAD SECTION SHOWN; SILL & SIDES ARE INSTALLED THE SAME)
 (FOR DETAIL NOT SHOWN, SEE OTHER SECTIONS)

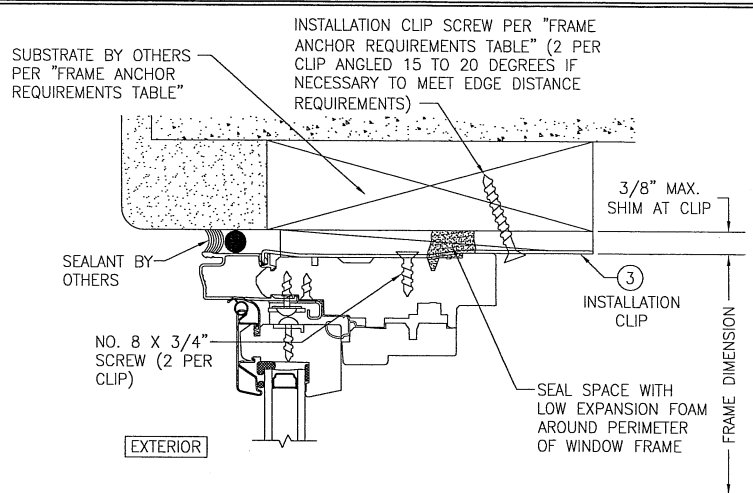

ALTERNATE INSTALLATION CLIP DETAIL
 (HEAD SECTION SHOWN; SILL & SIDES ARE INSTALLED THE SAME)
 (FOR DETAIL NOT SHOWN, SEE OTHER SECTIONS)

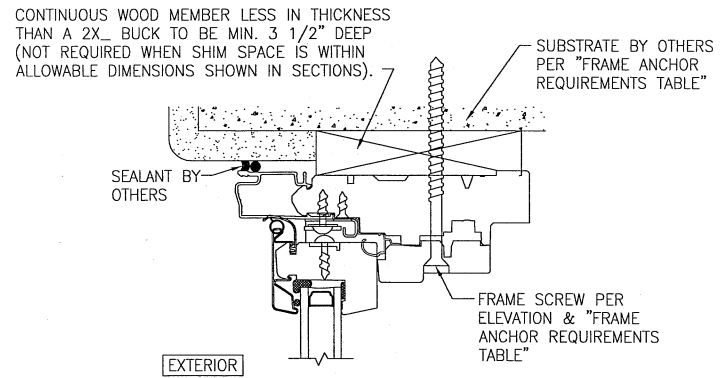

OPTIONAL DIRECT MOUNT DETAIL TO SUBSTRATE WITH SPACER
 (HEAD SECTION SHOWN; SILL & SIDES ARE INSTALLED THE SAME)
 (FOR DETAIL NOT SHOWN, SEE OTHER SECTIONS)

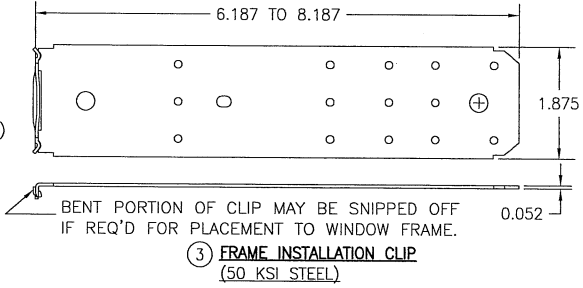
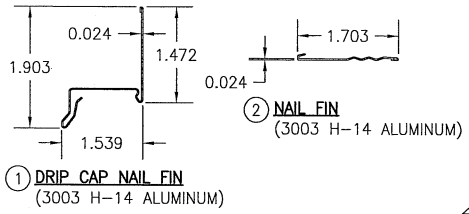

DRAWN BY:	W.W.S.	CHECKED BY:	W.W.S.
PLOT:	1=2	DATE:	06/08/16
DATE:			
BY:			
REVISION DESCRIPTION:			
NO.			

ARTCHITECT SERIES CONTEMPORARY NON-IMPACT CASEMENT WINDOWS

JOB INFORMATION:
Pella
 PELLA CORPORATION
 102 MAIN STREET
 PELLA, IA 50219
 641-621-1000

CONSULTANTS
W. W. SCHAEFER ENGINEERING & CONSULTING, P.A. (REG. NO. F-14980)
 7480 150TH COURT NORTH
 PALM BEACH GARDENS, FL 33418
 PHONE: 561-744-3624

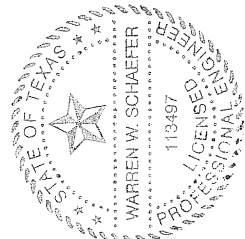

CERTIFICATION
 JUN 08 2016
 WARREN W. SCHAEFER, P.E.
 P.E. NO. 113497

DRAWING NO.	REV.
1920T	
SHEET NO.	
3	3