

REVISIONS			
REV	DESCRIPTION	DATE	APPROVED
A	REVISED PER TDI COMMENTS	07/16/19	R.L.

NOTES:

1. THE PRODUCT SHOWN HEREIN IS DESIGNED AND MANUFACTURED TO COMPLY WITH REQUIREMENTS OF THE 2006 IBC AND 2006 IRC WITH STATE OF TEXAS MODIFICATIONS, AND WITH THE 2009 IBC, 2009 IRC, 2012 IBC, 2012 IRC, 2015 IBC AND 2015 IRC.
2. WOOD FRAMING AND MASONRY OPENING TO BE DESIGNED AND ANCHORED TO PROPERLY TRANSFER ALL LOADS TO STRUCTURE. FRAMING AND MASONRY OPENING IS THE RESPONSIBILITY OF THE ARCHITECT OR ENGINEER OF RECORD.
3. 1X BUCK OVER MASONRY/CONCRETE IS OPTIONAL.
4. WHERE SHIM OR BUCK THICKNESS IS LESS THAN 1-1/2" WINDOW UNITS MUST BE ANCHORED THROUGH THE FRAME IN ACCORDANCE WITH MANUFACTURER'S PUBLISHED INSTALLATION INSTRUCTIONS. ANCHORS SHALL BE SECURELY FASTENED DIRECTLY INTO MASONRY, CONCRETE OR OTHER STRUCTURAL SUBSTRATE MATERIAL.
5. WHERE WOOD BUCK THICKNESS IS 1-1/2" OR GREATER, BUCK SHALL BE SECURELY FASTENED TO MASONRY, CONCRETE OR OTHER STRUCTURAL SUBSTRATE. WINDOW UNITS MAY BE ANCHORED THROUGH FRAME TO SECURED WOOD BUCK IN ACCORDANCE WITH MANUFACTURER'S PUBLISHED INSTALLATION INSTRUCTIONS.
6. WHERE 1X BUCK IS NOT USED DISSIMILAR MATERIALS MUST BE SEPARATED WITH APPROVED COATING OR MEMBRANE. SELECTION OF COATING OR MEMBRANE IS THE RESPONSIBILITY OF THE ARCHITECT OR ENGINEER OF RECORD.
7. BUCKS SHALL EXTEND BEYOND WINDOW INTERIOR FACE SO THAT FULL FRAME SUPPORT IS PROVIDED.
8. FOR FIN INSTALLATION SHIM AS NEEDED. FOR FRAME INSTALLATION SHIM AS REQUIRED AT EACH ANCHOR LOCATION WITH LOAD BEARING SHIM. SHIM WHERE SPACE OF 1/16" OR GREATER OCCURS. MAXIMUM ALLOWABLE SHIM STACK TO BE 1/4".
9. SHIMS SHALL BE LOCATED, APPLIED AND MADE FROM MATERIALS AND THICKNESS CAPABLE OF SUSTAINING APPLICABLE LOADS.
10. WIND LOAD DURATION FACTOR Cd=1.6 WAS USED FOR WOOD ANCHOR CALCULATIONS.
11. FRAME MATERIAL: EXTRUDED RIGID PVC.
12. UNITS MUST BE GLAZED PER ASTM E1300-04/09.
13. APPROVED IMPACT PROTECTIVE SYSTEM IS REQUIRED FOR THIS PRODUCT IN WIND BORNE DEBRIS REGIONS.
14. FOR ANCHORING THROUGH FIN INTO WOOD FRAMING OR 2X BUCK USE #8 WOOD SCREWS WITH SUFFICIENT LENGTH TO ACHIEVE A 1 1/4" MINIMUM EMBEDMENT INTO SUBSTRATE. LOCATE ANCHORS AS SHOWN IN ELEVATIONS AND INSTALLATION DETAILS.

15. FOR ANCHORING THROUGH FRAME INTO WOOD FRAMING OR 2X BUCK USE #12 WOOD SCREWS WITH SUFFICIENT LENGTH TO ACHIEVE A 1 3/8" MINIMUM EMBEDMENT INTO SUBSTRATE. LOCATE ANCHORS AS SHOWN IN ELEVATIONS AND INSTALLATION DETAILS.
16. FOR ANCHORING THROUGH FRAME INTO MASONRY/CONCRETE USE 1/4" TAPCONS WITH SUFFICIENT LENGTH TO ACHIEVE A 1 1/4" MINIMUM EMBEDMENT INTO SUBSTRATE WITH 2" MINIMUM EDGE DISTANCE. LOCATE ANCHORS AS SHOWN IN ELEVATIONS AND INSTALLATION DETAILS.
17. FOR ANCHORING THROUGH FRAME INTO METAL STRUCTURE USE #12 SMS OR SELF DRILLING SCREWS WITH SUFFICIENT LENGTH TO ACHIEVE 3 THREADS MINIMUM BEYOND STRUCTURE INTERIOR WALL. LOCATE ANCHORS AS SHOWN IN ELEVATIONS AND INSTALLATION DETAILS.
18. ALL FASTENERS TO BE CORROSION RESISTANT.
19. INSTALLATION ANCHORS SHALL BE INSTALLED IN ACCORDANCE WITH ANCHOR MANUFACTURER'S INSTALLATION INSTRUCTIONS AND ANCHORS SHALL NOT BE USED IN SUBSTRATES WITH STRENGTHS LESS THAN THE MINIMUM STRENGTH SPECIFIED BELOW:
 - A. WOOD: MINIMUM SPECIFIC GRAVITY OF G=0.42
 - B. CONCRETE: MINIMUM COMPRESSIVE STRENGTH OF 2,000 PSI.
 - C. MASONRY: HOLLOW/FILLED BLOCK PER ASTM C90 WITH f'm=2,000PSI MINIMUM.
 - D. METAL STRUCTURE: STEEL 18GA (.048") FY=33KSI/FU=52KSI OR ALUMINUM 6063-T5 FU=30KSI .048" THICK MINIMUM.
20. APPROVED CONFIGURATIONS: XOx, OX, XO.

SIGNED: 08/29/2019

TABLE OF CONTENTS	
SHEET NO.	DESCRIPTION
1	NOTES
2 - 3	ELEVATIONS
4 - 7	INSTALLATION DETAILS

VISTAMARK ENTERPRISES, LLC 3637 N HIGHWAY 77, SUITE C WAXAHACHIE, TX 75165		
SERIES ENDURA 120/130 PVC HORIZONTAL SLIDING WINDOW XOx REINFORCED NON-IMPACT NOTES		
DRAWN: R.L.	DWG NO. 08-02765	REV A
SCALE NTS	DATE 07/31/15	SHEET 1 OF 7
L. ROBERTO LOMAS P.E. 1432 WOODFORD RD LEWISVILLE, NC 27023 434-688-0609 rllomas@rlomaspe.com		



Luis R. Lomas P.E.
TX No.: 101889

REVISIONS			
REV	DESCRIPTION	DATE	APPROVED
A	REVISED PER TDI COMMENTS	07/16/19	R.L.

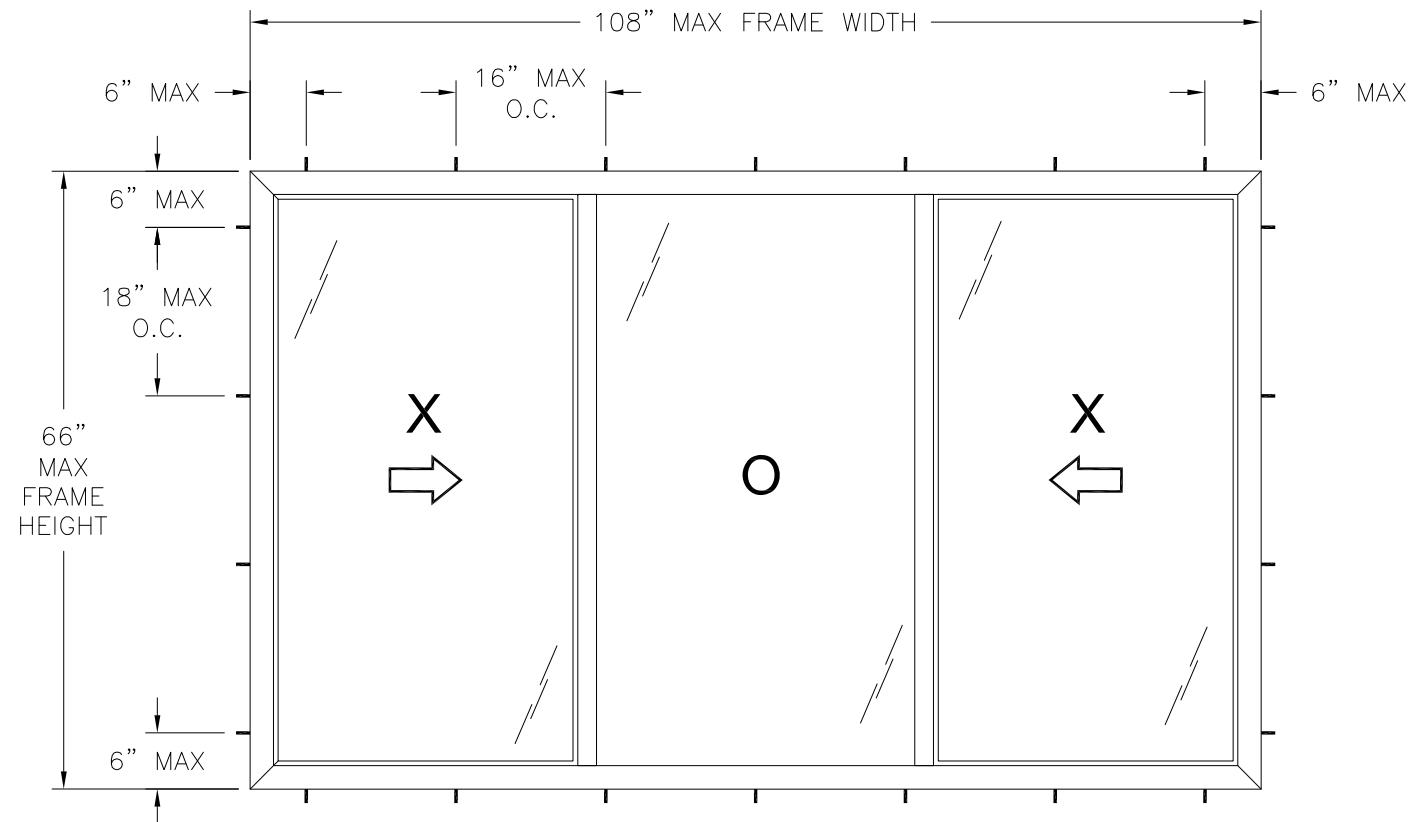

SERIES ENDURA 120/130 HORIZONTAL SLIDING WINDOW
EXTERIOR VIEW
FRAME INSTALLATION

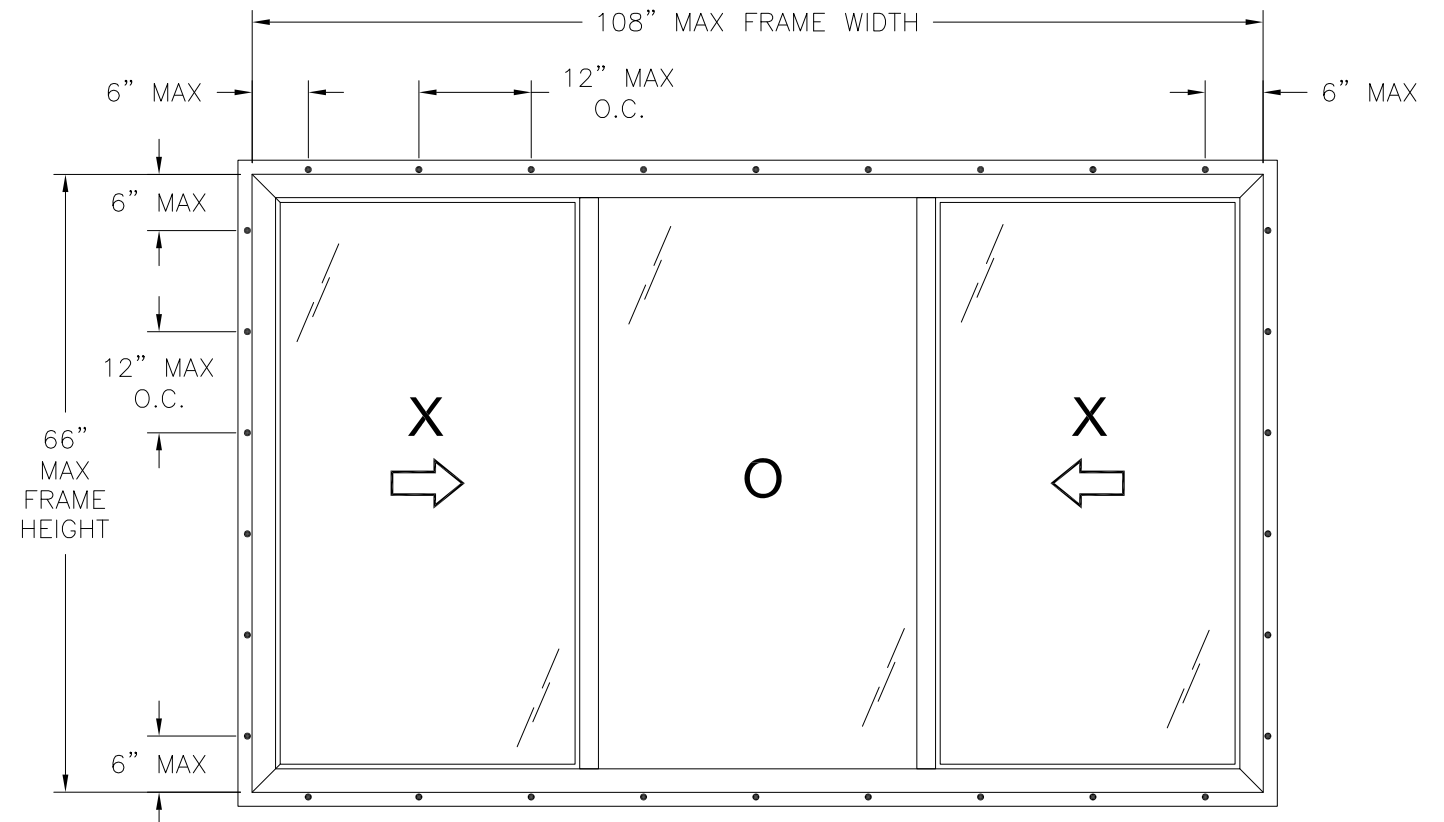

SERIES ENDURA 120/130 HORIZONTAL SLIDING WINDOW
EXTERIOR VIEW
FIN INSTALLATION

DESIGN PRESSURE RATING	IMPACT RATING
±40.0PSF	NONE

NOTES:

1. MAXIMUM SASH SIZE: 35 7/8" X 63 1/4"
2. MAXIMUM D.L.O.: 32 1/2" X 61 1/16"

HARDWARE SCHEDULE

A.	(4) COMPOSITE LOCK AT 8 1/2" FROM EACH END OF FIXED MEETING RAIL
B.	(4) COMPOSITE ROLLERS AT EACH END OF BOTTOM RAIL
C.	EXTRUDED ALUMINUM REINFORCEMENT (10300278) AT FIXED MEETING STILES
D.	EXTRUDED ALUMINUM REINFORCEMENT (10300277) AT LOCK STILE

SIGNED: 08/29/2019

VISTAMARK ENTERPRISES, LLC
3637 N HIGHWAY 77, SUITE C
WAXAHACHIE, TX 75165

SERIES ENDURA 120/130 PVC HORIZONTAL SLIDING WINDOW
WINDOW XOX REINFORCED NON-IMPACT
108" X 66" ELEVATION

DRAWN: R.L.	DWG NO. 08-02765	REV A
SCALE NTS	DATE 07/31/15	SHEET 2 OF 7

L. ROBERTO LOMAS P.E.
1432 WOODFORD RD LEWISVILLE, NC 27023
434-688-0609 rllomas@rlomaspe.com



Luis R. Lomas P.E.
TX No.: 101889

REVISIONS			
REV	DESCRIPTION	DATE	APPROVED
A	REVISED PER TDI COMMENTS	07/16/19	R.L.

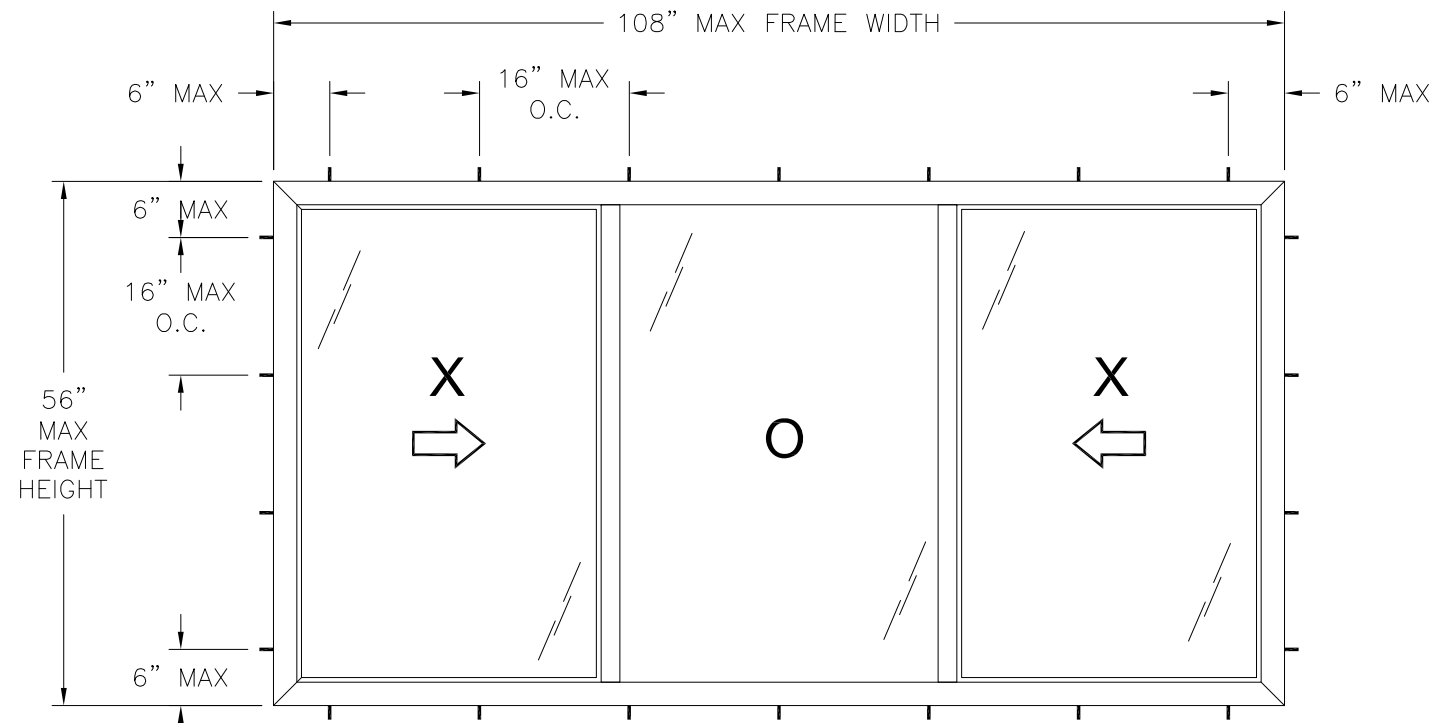

SERIES ENDURA 120/130 HORIZONTAL SLIDING WINDOW
EXTERIOR VIEW
FRAME INSTALLATION

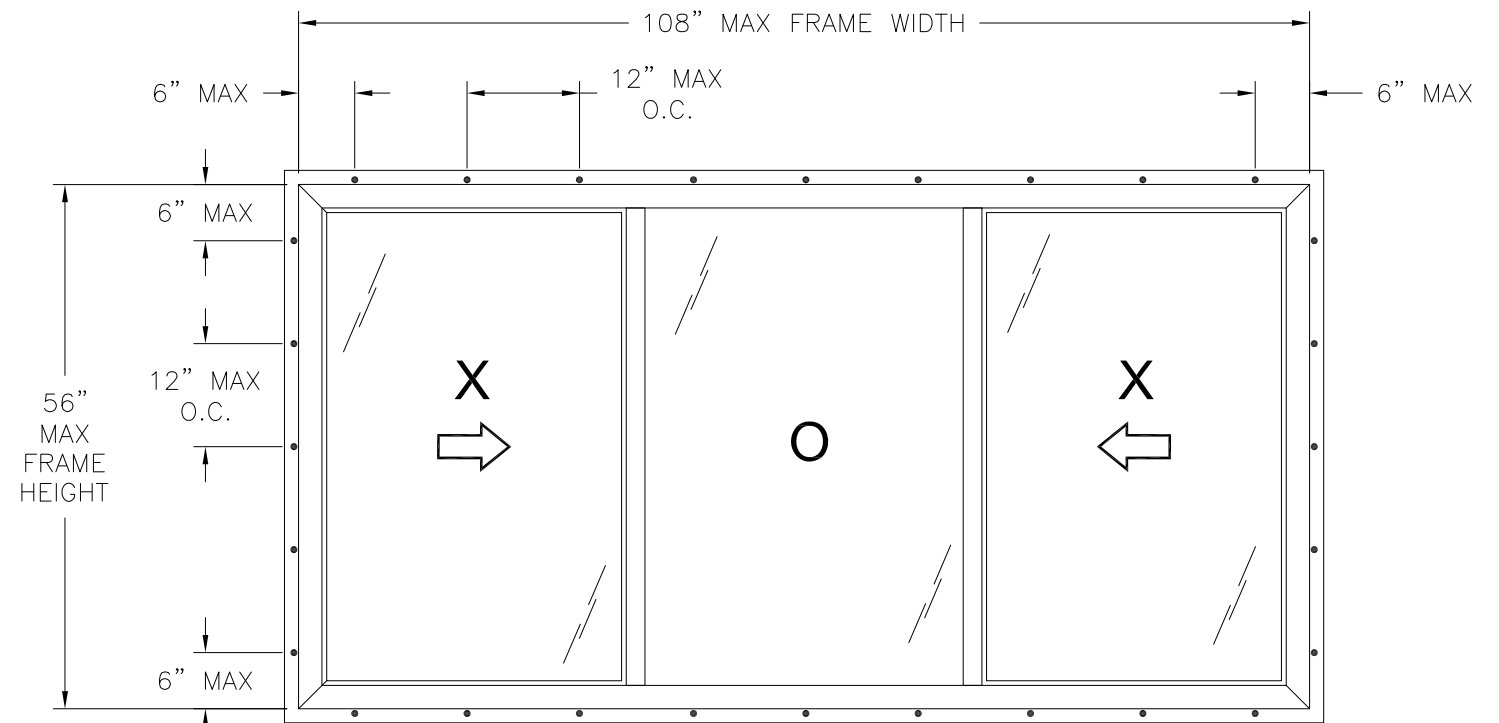

SERIES ENDURA 120/130 HORIZONTAL SLIDING WINDOW
EXTERIOR VIEW
FIN INSTALLATION

DESIGN PRESSURE RATING	IMPACT RATING
+50.0/-55.0PSF	NONE

NOTES:

1. MAXIMUM SASH SIZE: 35 1/4" X 53 1/4"
2. MAXIMUM D.L.O.: 33 7/8" X 51 1/8"

HARDWARE SCHEDULE

A.	(4) COMPOSITE LOCK AT 8 1/2" FROM EACH END OF FIXED MEETING RAIL
B.	(4) COMPOSITE ROLLERS AT EACH END OF BOTTOM RAIL
C.	EXTRUDED ALUMINUM REINFORCEMENT (10300278) AT FIXED MEETING STILES
D.	EXTRUDED ALUMINUM REINFORCEMENT (10300277) AT LOCK STILE

SIGNED: 08/29/2019

VISTAMARK ENTERPRISES, LLC

3637 N HIGHWAY 77, SUITE C
WAXAHACHIE, TX 75165

SERIES ENDURA 120/130 PVC HORIZONTAL SLIDING
WINDOW XOX REINFORCED NON-IMPACT
108" X 56" ELEVATION

DRAWN: R.L.	DWG NO. 08-02765	REV A
----------------	---------------------	----------

SCALE NTS	DATE 07/31/15	SHEET 3 OF 7
-----------	---------------	--------------

L. ROBERTO LOMAS P.E.
1432 WOODFORD RD LEWISVILLE, NC 27023
434-688-0609 rllomas@lrlomaspe.com



Luis R. Lomas P.E.
TX No.: 101889

REVISIONS			
REV	DESCRIPTION	DATE	APPROVED
A	REVISED PER TDI COMMENTS	07/16/19	R.L.

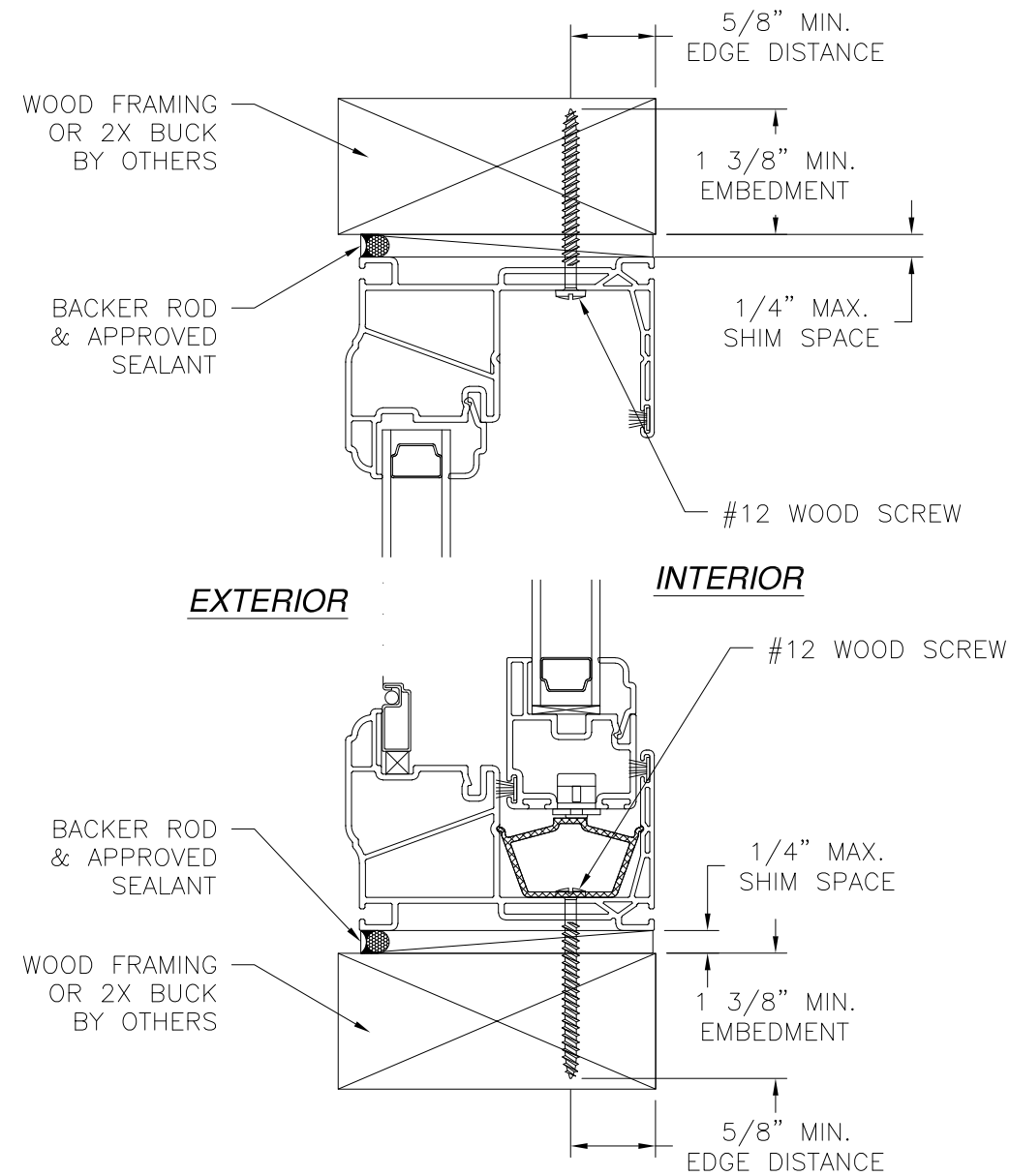

VERTICAL CROSS SECTION
WOOD FRAMING OR 2X BUCK INSTALLATION

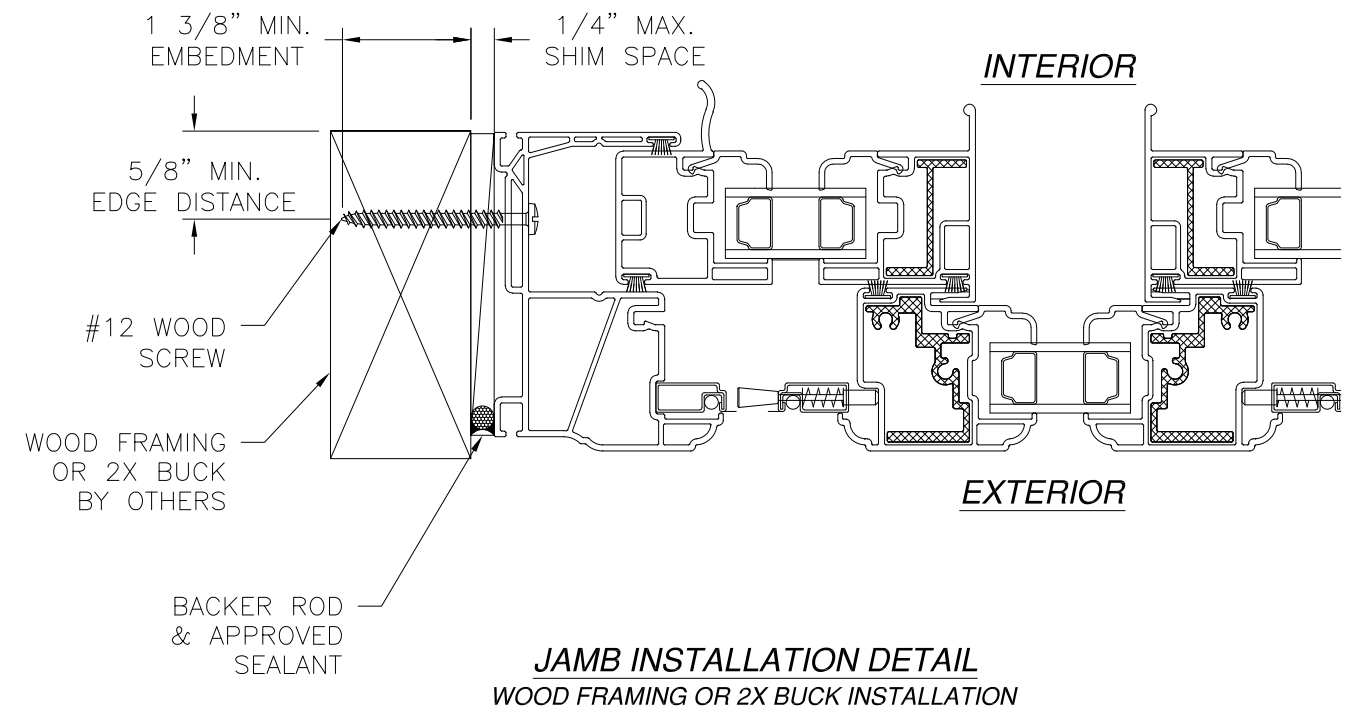

JAMB INSTALLATION DETAIL
WOOD FRAMING OR 2X BUCK INSTALLATION

NOTES:

1. INTERIOR AND EXTERIOR FINISHES, BY OTHERS, NOT SHOWN FOR CLARITY.
2. PERIMETER AND JOINT SEALANT BY OTHERS TO BE DESIGNED IN ACCORDANCE WITH ASTM E2112

SIGNED: 08/29/2019

VISTAMARK ENTERPRISES, LLC 3637 N HIGHWAY 77, SUITE C WAXAHACHIE, TX 75165		
SERIES ENDURA 120/130 PVC HORIZONTAL SLIDING WINDOW XOX REINFORCED NON-IMPACT INSTALLATION DETAILS		
DRAWN: R.L.	DWG NO. 08-02765	REV A
SCALE NTS	DATE 07/31/15	SHEET 4 OF 7
L. ROBERTO LOMAS P.E. 1432 WOODFORD RD LEWISVILLE, NC 27023 434-688-0609 rllomas@rlomaspe.com		



Luis R. Lomas P.E.
TX No.: 101889

REVISIONS			
REV	DESCRIPTION	DATE	APPROVED
A	REVISED PER TDI COMMENTS	07/16/19	R.L.

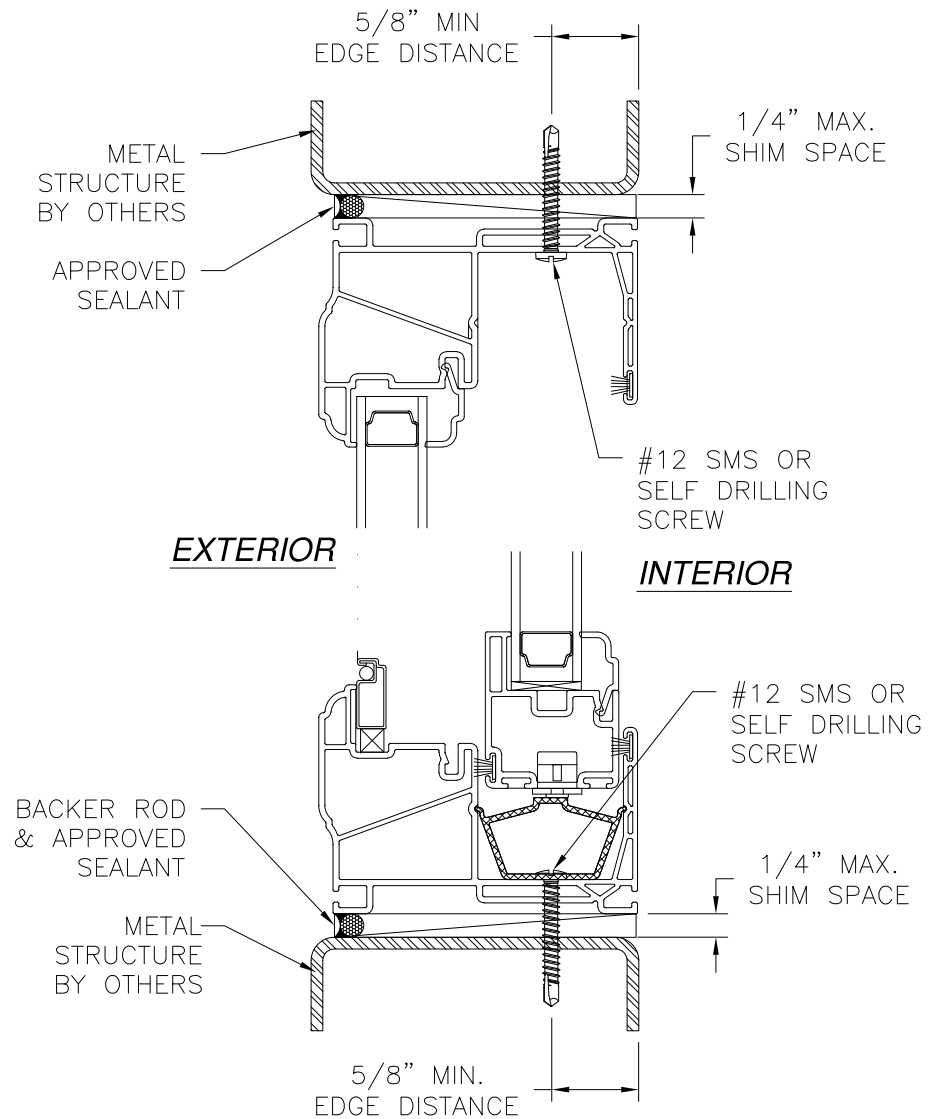

VERTICAL CROSS SECTION
METAL STRUCTURE INSTALLATION

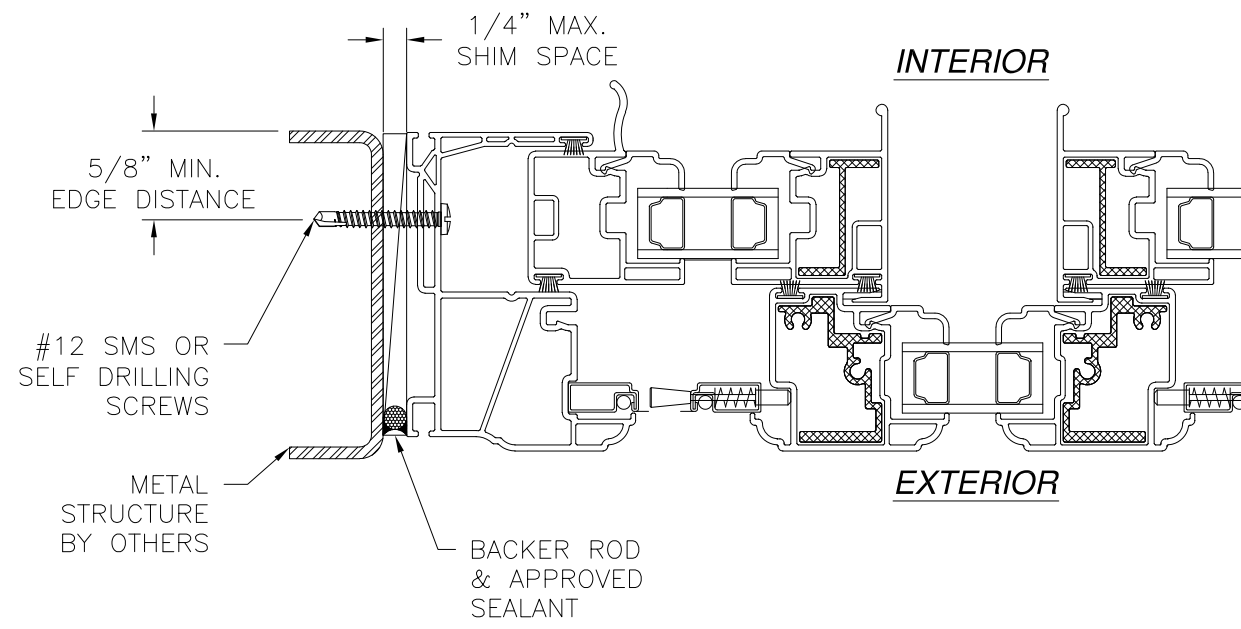

JAMB INSTALLATION DETAIL
METAL STRUCTURE INSTALLATION

- NOTES:**
1. INTERIOR AND EXTERIOR FINISHES, BY OTHERS, NOT SHOWN FOR CLARITY.
 2. PERIMETER AND JOINT SEALANT BY OTHERS TO BE DESIGNED IN ACCORDANCE WITH ASTM E2112

SIGNED: 08/29/2019

VISTAMARK ENTERPRISES, LLC 3637 N HIGHWAY 77, SUITE C WAXAHACHIE, TX 75165		
SERIES ENDURA 120/130 PVC HORIZONTAL SLIDING WINDOW XOX REINFORCED NON-IMPACT INSTALLATION DETAILS		
DRAWN: R.L.	DWG NO. 08-02765	REV A
SCALE NTS	DATE 07/31/15	SHEET 5 OF 7
L. ROBERTO LOMAS P.E. 1432 WOODFORD RD LEWISVILLE, NC 27023 434-688-0609 rllomas@rlomaspe.com		



Luis R. Lomas P.E.
TX No.: 101889

REVISIONS			
REV	DESCRIPTION	DATE	APPROVED
A	REVISED PER TDI COMMENTS	07/16/19	R.L.

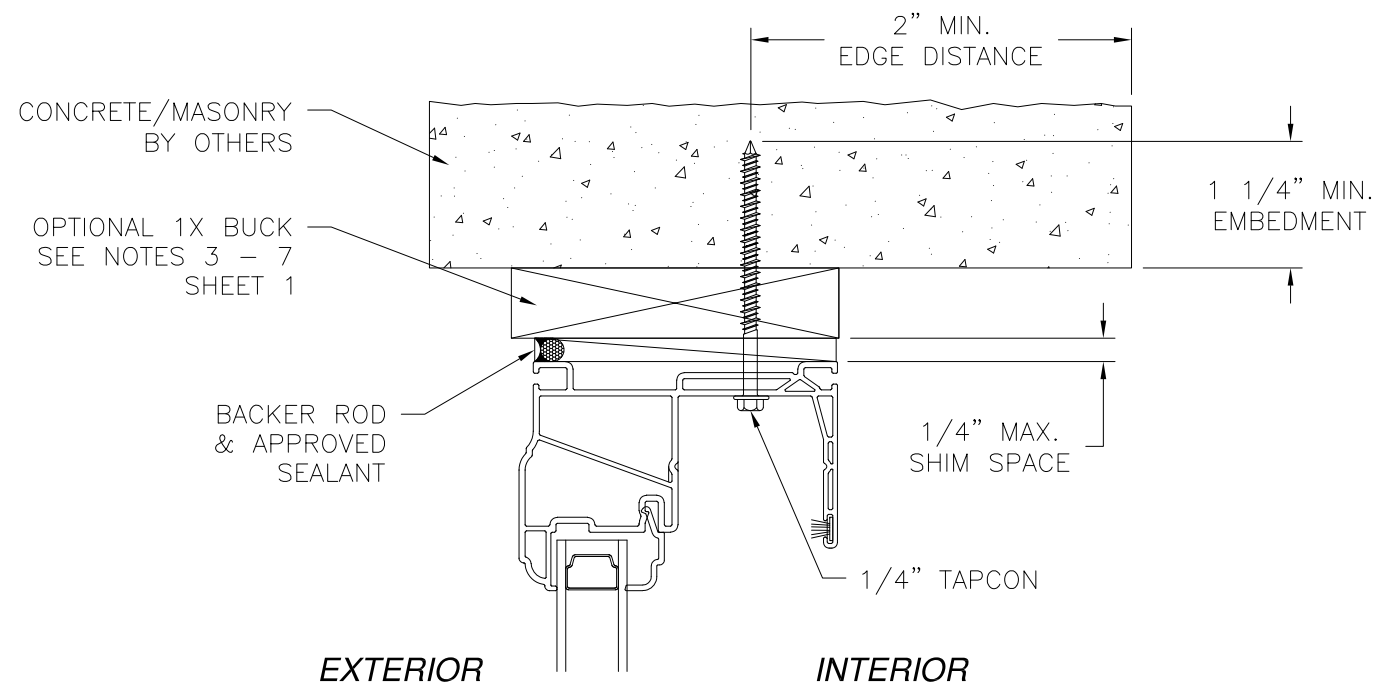

EXTERIOR **INTERIOR**

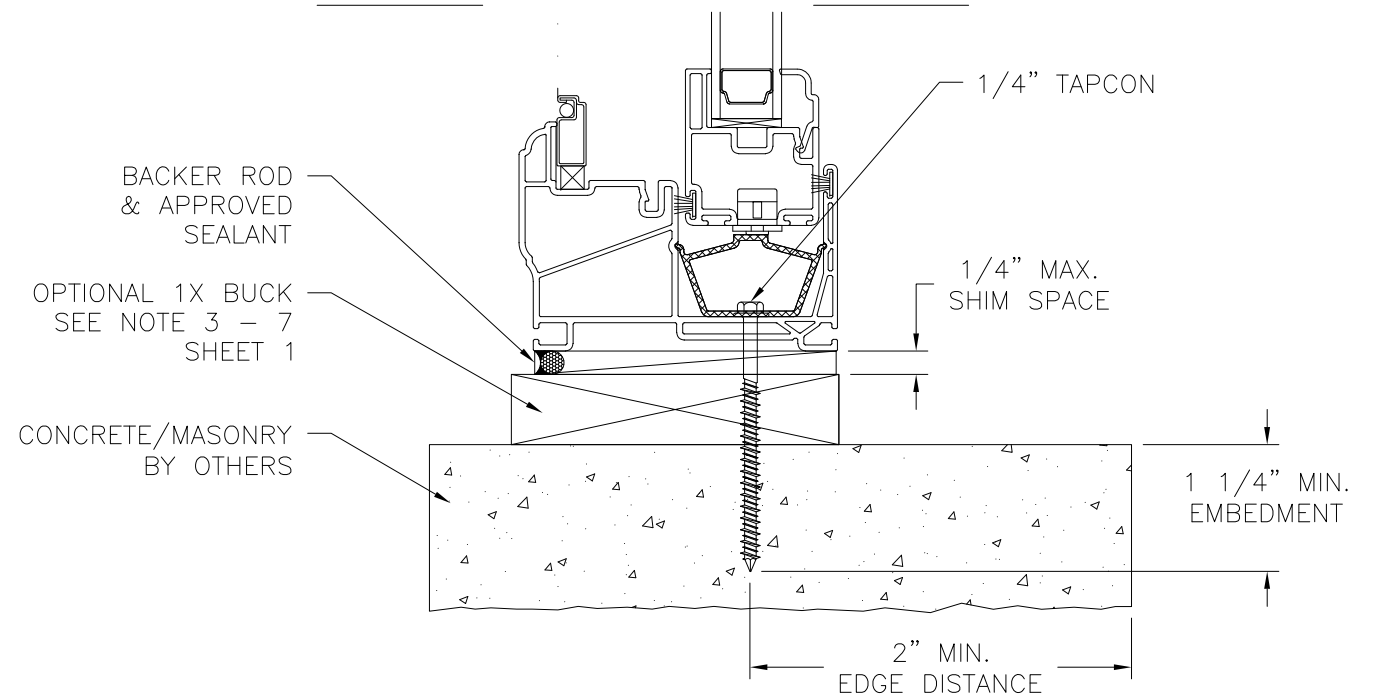

**VERTICAL CROSS SECTION
CONCRETE/MASONRY INSTALLATION**

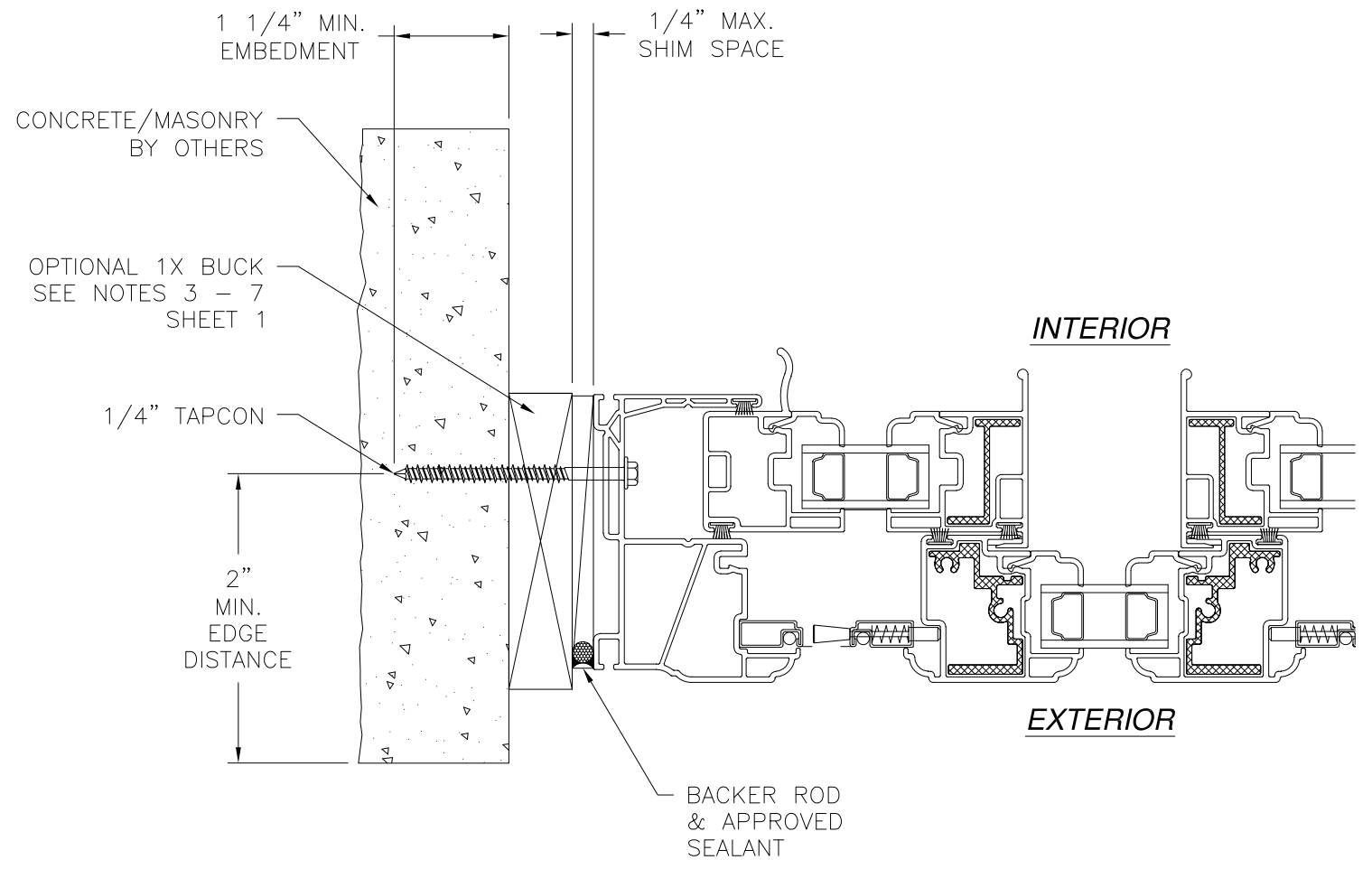

**JAMB INSTALLATION DETAIL
CONCRETE/MASONRY INSTALLATION**

- NOTES:**
1. INTERIOR AND EXTERIOR FINISHES, BY OTHERS, NOT SHOWN FOR CLARITY.
 2. PERIMETER AND JOINT SEALANT BY OTHERS TO BE DESIGNED IN ACCORDANCE WITH ASTM E2112

SIGNED: 08/29/2019

VISTAMARK ENTERPRISES, LLC
 3637 N HIGHWAY 77, SUITE C
 WAXAHACHIE, TX 75165

SERIES ENDURA 120/130 PVC HORIZONTAL SLIDING WINDOW XOX REINFORCED NON-IMPACT INSTALLATION DETAILS

DRAWN: R.L.	DWG NO. 08-02765	REV A
SCALE NTS	DATE 07/31/15	SHEET 6 OF 7

L. ROBERTO LOMAS P.E.
 1432 WOODFORD RD LEWISVILLE, NC 27023
 434-688-0609 rllomas@rlomaspe.com



Luis R. Lomas P.E.
 TX No.: 101889

REVISIONS			
REV	DESCRIPTION	DATE	APPROVED
A	REVISED PER TDI COMMENTS	07/16/19	R.L.

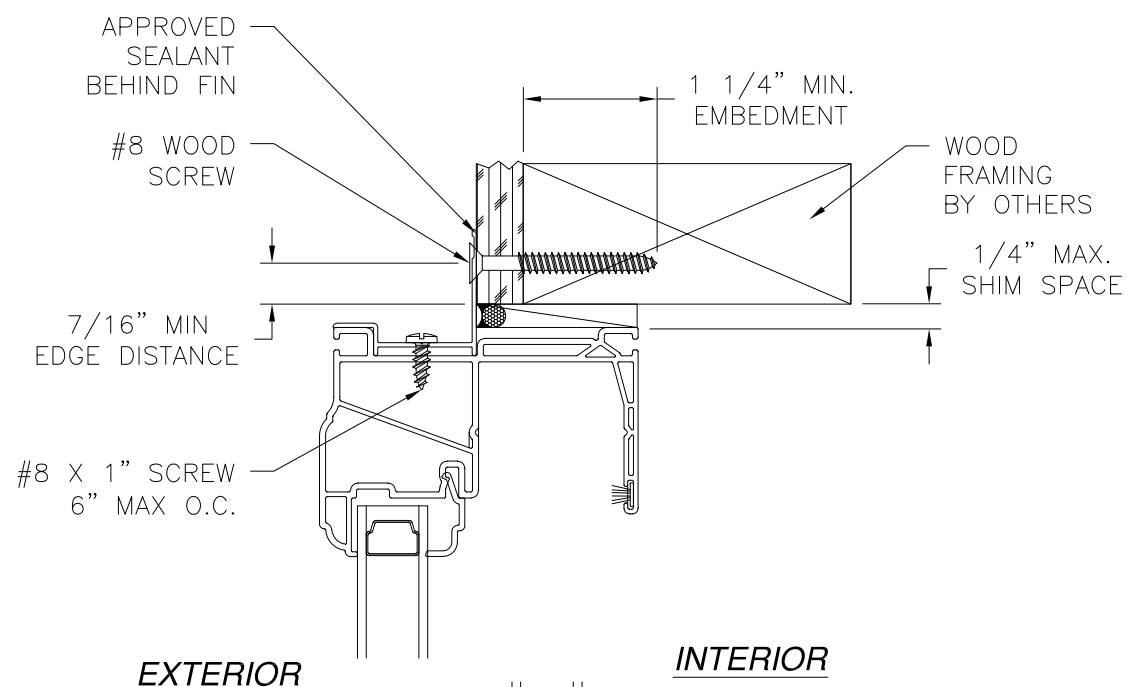

EXTERIOR

INTERIOR

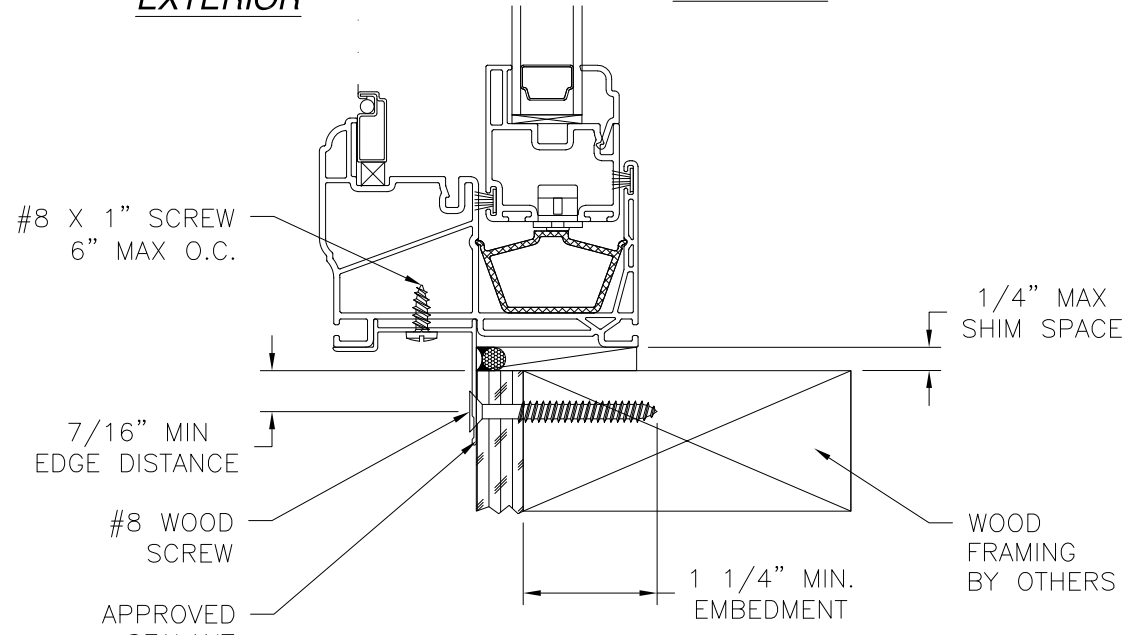

VERTICAL CROSS SECTION
WOOD FRAMING OR 2X BUCK INSTALLATION

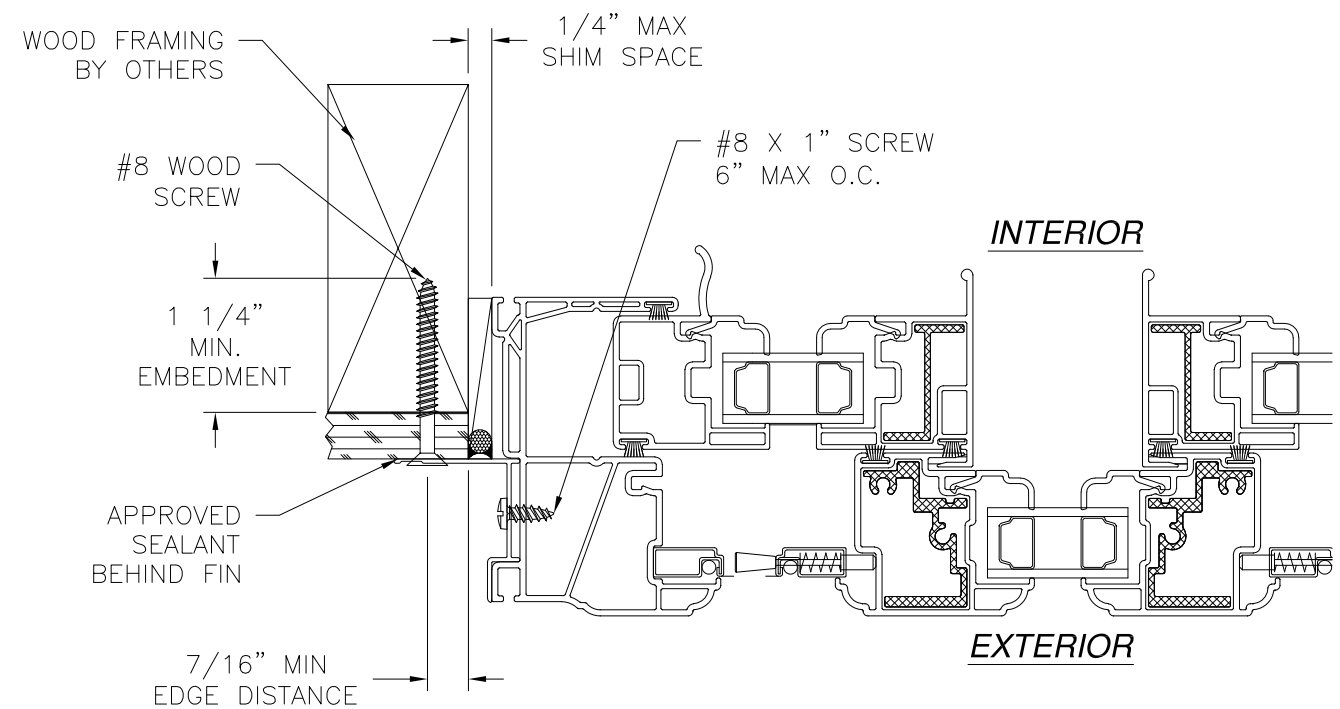

JAMB INSTALLATION DETAIL
WOOD FRAMING OR 2X BUCK INSTALLATION

- NOTES:**
1. INTERIOR AND EXTERIOR FINISHES, BY OTHERS, NOT SHOWN FOR CLARITY.
 2. PERIMETER AND JOINT SEALANT BY OTHERS TO BE DESIGNED IN ACCORDANCE WITH ASTM E2112

SIGNED: 08/29/2019

VISTAMARK ENTERPRISES, LLC 3637 N HIGHWAY 77, SUITE C WAXAHACHIE, TX 75165		
SERIES ENDURA 120/130 PVC HORIZONTAL SLIDING WINDOW XOX REINFORCED NON-IMPACT INSTALLATION DETAILS		
DRAWN: R.L.	DWG NO. 08-02765	REV A
SCALE NTS	DATE 07/31/15	SHEET 7 OF 7
L. ROBERTO LOMAS P.E. 1432 WOODFORD RD LEWISVILLE, NC 27023 434-688-0609 rllomas@rlomaspe.com		



Luis R. Lomas P.E.
TX No.: 101889