

IMPACT RATING	DESIGN PRESSURE RATING
LARGE & SMALL MISSILE IMPACT RESISTANT	SEE TABLE 1

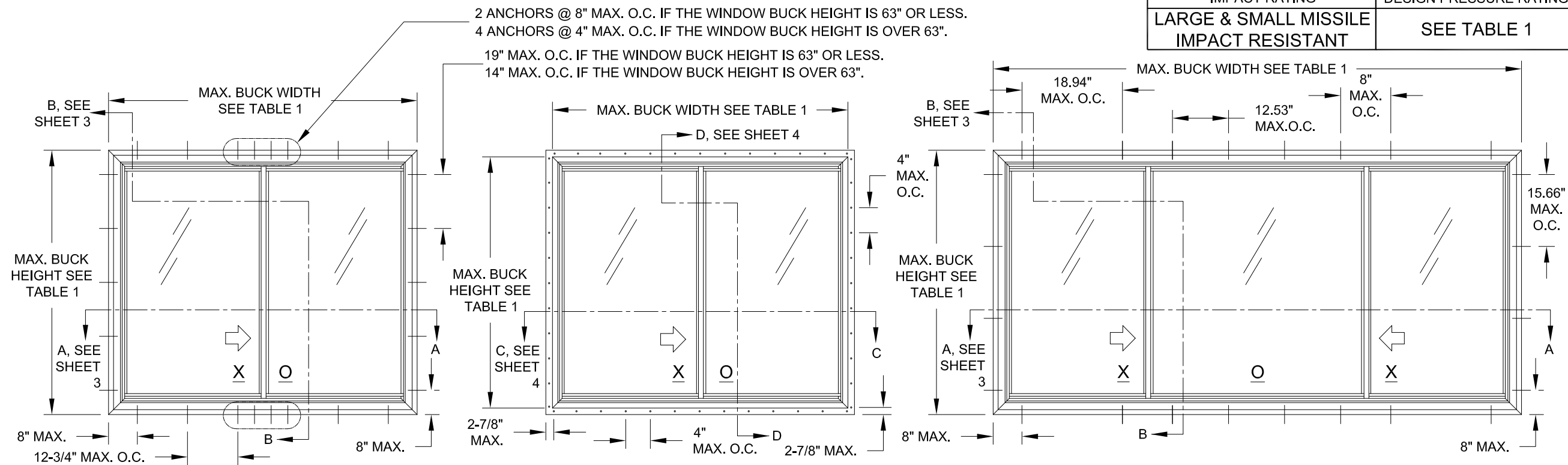

ELEVATION FOR TYP. EQUAL LEG/BOX & FLANGE FRAME, XO CONFIGURATION, OX SIMILAR

ELEVATION FOR TYP. FIN OR J-CHANNEL FRAME, XO CONFIGURATION, OX & XOX SIMILAR

ELEVATION FOR TYP. EQUAL LEG/BOX & FLANGE FRAME, XOX CONFIGURATION
MAX. SASH WIDTH = 30.36"
MAX. FIXED LITE (BUCK WIDTH - [2 X SASH WIDTH]) = 59.28"

GENERAL NOTES: SERIES 5510 IMPACT RESISTANT, VINYL HORIZONTAL ROLLER

1) THIS PRODUCT HAS BEEN DESIGNED & TESTED TO COMPLY WITH THE REQUIREMENTS OF THE 2018 INTERNATIONAL BUILDING CODE (IBC) AND THE 2018 INTERNATIONAL RESIDENTIAL CODE (IRC) FOR THE DESIGN PRESSURES LISTED.

2) ALL WOOD BUCKS LESS THAN 1-1/2" THICK ARE TO BE CONSIDERED 1X INSTALLATIONS. 1X WOOD BUCKS ARE OPTIONAL IF UNIT IS INSTALLED DIRECTLY TO SUBSTRATE. WOOD BUCKS DEPICTED AS 2X ARE 1-1/2" THICK OR GREATER. 1X AND 2X BUCKS (WHEN USED) SHALL BE DESIGNED TO PROPERLY TRANSFER LOADS TO THE STRUCTURE. WOOD BUCK DESIGN AND INSTALLATION IS THE RESPONSIBILITY OF THE ENGINEER, (EOR) OR ARCHITECT OF RECORD, (AOR).

3) ANCHOR EMBEDMENT TO BASE MATERIAL SHALL BE BEYOND WALL DRESSING OR STUCCO. USE ANCHORS OF SUFFICIENT EMBEDMENT. INSTALLATION ANCHORS SHOULD BE SEALED. OVERALL SEALING/FLASHING STRATEGY FOR WATER RESISTANCE OF INSTALLATION SHALL BE DONE BY OTHERS AND IS BEYOND THE SCOPE OF THESE INSTRUCTIONS.

4) MAX. 1/4" SHIMS ARE REQUIRED AT EACH ANCHOR LOCATION WHERE THE PRODUCT IS NOT FLUSH TO THE SUBSTRATE. USE SHIMS CAPABLE OF TRANSFERRING APPLIED LOADS. WOOD BUCKS, BY OTHERS, MUST BE SUFFICIENTLY ANCHORED TO RESIST LOADS IMPOSED ON THEM BY THE WINDOW.

5) THE ANCHORAGE METHODS SHOWN HAVE BEEN DESIGNED TO RESIST THE WINDLOADS CORRESPONDING TO THE REQUIRED DESIGN PRESSURE. THE 33-1/3% STRESS INCREASE HAS NOT BEEN USED IN THE DESIGN OF THIS PRODUCT. THE 1.6 LOAD DURATION FACTOR WAS USED FOR THE EVALUATION OF ANCHORS INTO WOOD. ANCHORS SHALL BE COATED OR CORROSION RESISTANT AS SPECIFIED IN THE IBC/IRC.

TABLE 1:

Window Buck Size		Configuration	Reinf. Level	Design Pressure		Glass Types	Certification (CAR) Number
Width	Height			(+) psf	(-) psf		
75"	63"	XO/OX	R3	50.0	50.0	5-8	190-292, 1048
75"	63"	XO/OX	R4	60.0	60.0	5	190-290, 1074
75"	63"	XO/OX	R4	65.0	70.0	5-8	190-291, 1047
75"	72"	XO/OX	R4	50.0	50.0	5-8	190-289, 1046
120"	63"	XOX (1/4-1/2-1/4)	R3	45.0	45.0	5	190-297, 1053
92"	63"	XOX (1/3-1/3-1/3)					
120"	63"	XOX (1/4-1/2-1/4)	R3	50.0	50.0	5-8	190-298, 1054
92"	63"	XOX (1/3-1/3-1/3)					
120"	63"	XOX (1/4-1/2-1/4)	R4	65.0	65.0	7	190-295, 1051
92"	63"	XOX (1/3-1/3-1/3)					
120"	63"	XOX (1/4-1/2-1/4)	R4	65.0	70.0	7 & 8	190-296, 1052
92"	63"	XOX (1/3-1/3-1/3)					

SEE SHEET 2 FOR GLASS TYPES

COPYRIGHT © 2021 PGT INDUSTRIES, INC. LIMITED LICENSE TO MAKE COPIES FOR PERMITTING.



1070 TECHNOLOGY DRIVE
N. VENICE, FL 34275
(941)-480-1600

Series	Rev 1	Desc.	Rev 1	Title	Date
		VINYL HR WINDOW TDI (IMP.-RESIST.)			3/17/15
		GENERAL NOTES & ELEVATIONS	Drawn By	J ROSOWSKI	
		UPDATED CODE & ANCHORS - JR	Rev 1 Date		6/25/21
HR-5510	Scale	NTS	Sheet	1 OF 4	DWG No.
					TDI-HR5510.1
					Rev. No.
					A



A Lynn Miller 7/16/21
A. LYNN MILLER, P.E.
P.E.# 106954

TABLE 2: ANCHORS INSTALLED THROUGH FRAME

Anchor	Substrate	Min. Edge Distance	Min. Embedment
#10 SMS (steel, 18-8 S.S. or 410 S.S.) Max. DP of 50.0 psf	P.T. Southern Pine (SG=0.55)	7/16"	1-3/8"
	Steel, A36	3/8"	0.050"
	Steel Stud, A653 Gr. 33	3/8"	0.0346" (20 Ga.)
	Aluminum, 6063-T5	3/8"	0.0713" (14 Ga.)
#12 SMS (steel, 18-8 S.S. or 410 S.S.)	P.T. Southern Pine (SG=0.55)	9/16"	1-3/8"
	Steel, A36	3/8"	0.050"
	Steel Stud, A653 Gr. 33	3/8"	0.0346" (20 Ga.)
	Aluminum, 6063-T5	3/8"	0.0713" (14 Ga.)
3/16" Ultracon Max. DP of 50.0 psf	P.T. Southern Pine (SG=0.55)	7/16"	1-3/8"
	Concrete (min. 2.85 ksi)	1"	1-3/8"
	UngROUTED CMU, (ASTM C-90)	2-1/2"	1-1/4"
3/16" Ultracon+ Max. DP of 50.0 psf	P.T. Southern Pine (SG=0.55)	7/16"	1-3/8"
	Concrete (min. 3 ksi)	1"	1-3/8"
	UngROUTED CMU, (ASTM C-90)	1"	1-1/4"
1/4" Ultracon	P.T. Southern Pine (SG=0.55)	1"	1-3/8"
	Concrete (min. 2.85 ksi)	1"	1-3/4"
	UngROUTED CMU, (ASTM C-90)	2-1/2"	1-1/4"
1/4" Ultracon+	P.T. Southern Pine (SG=0.55)	1"	1-3/8"
	Concrete (min. 3 ksi)	1-3/16"	1-3/4"
	UngROUTED CMU, (ASTM C-90)	1"	1-1/4"
1/4" Crete-Flex (410 S.S.)	P.T. Southern Pine (SG=0.55)	1"	1-3/8"
	Concrete (min. 3.35 ksi)	1"	1-3/4"
	UngROUTED CMU, (ASTM C-90)	2-1/2"	1-1/4"
1/4" Aggre-Gator (18-8 S.S.)	Concrete (min. 3.275 ksi)	1-1/2"	1-3/8"
	P.T. Southern Pine (SG=0.55)	1"	1-3/8"
	UngROUTED CMU, (ASTM C-90)	2"	1-1/4"

TABLE 3: ANCHORS INSTALLED THROUGH INTEGRAL FIN

Anchor	Substrate	Min. Edge Distance	Min. Embedment
2-1/2" x .131" Common Nail Max. DP of 50 psf	P.T. Southern Pine (SG=.55)	9/16"	2-7/16"
	P.T. Southern Pine (SG=.55)	9/16"	2-7/16"
2-1/2" x .131" Ring-shank Nail	P.T. Southern Pine (SG=.55)	9/16"	2-7/16"
2-1/2" x .145" Roofing Nail	P.T. Southern Pine (SG=.55)	9/16"	2-7/16"
#10 SMS (steel, 18-8 S.S. or 410 S.S.)	P.T. Southern Pine (SG=.55)	3/4"	1-3/8"
	Aluminum, 6063-T5	3/8"	0.050"
	Steel Stud, Gr. 33	3/8"	0.0346" (20 Ga.)
	Steel, A36	3/8"	0.050"

ANCHOR NOTES:

- 1) "UNGROUTED CMU" VALUES MAY BE USED FOR GROUDED CMU APPLICATIONS.
- 2) PANHEAD, FLATHEAD OR HEXHEAD ARE ACCEPTABLE.
- 3) ANCHOR LENGTH TO BE SO THAT A MIN. OF 3 THREADS EXTEND BEYOND THE METAL SUBSTRATE.

TABLE 4: REINFORCEMENT TYPES

Reinforcement		
Level	Vent (4 sides)	Meeting Rail
R3	B	E
R4	C	F

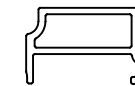

REINFORCMENT TYPE B

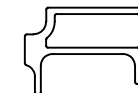

REINFORCMENT TYPE C

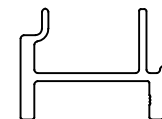

REINFORCMENT TYPE E

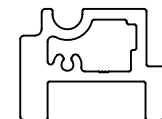

REINFORCMENT TYPE F

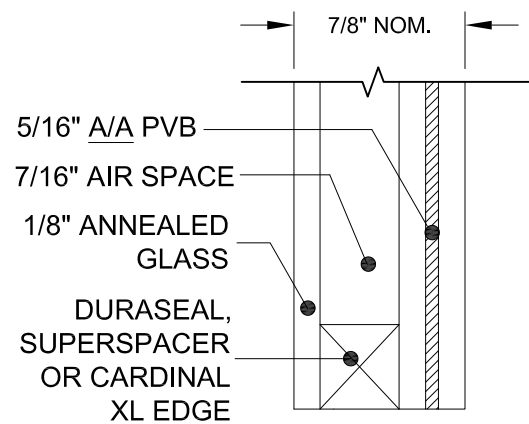

GLASS TYPE 5

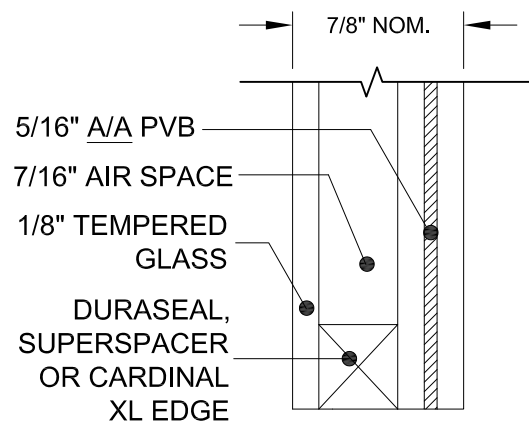

GLASS TYPE 6

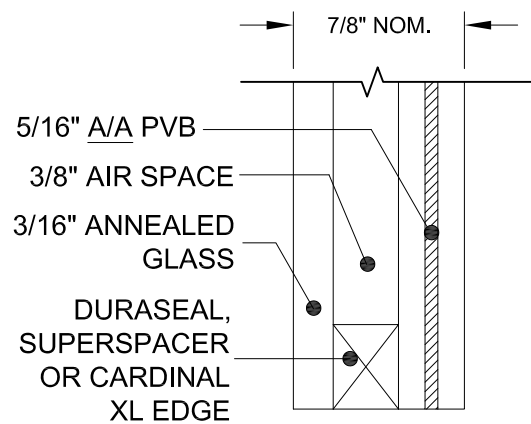

GLASS TYPE 7

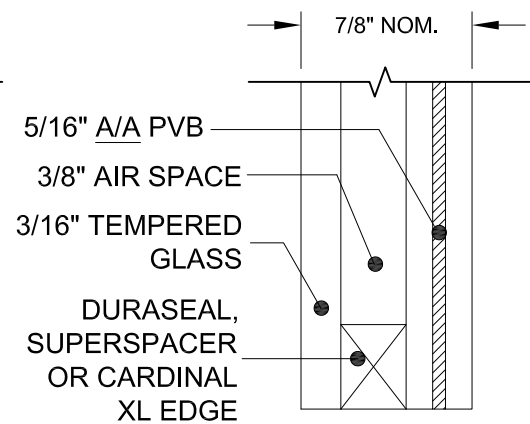

GLASS TYPE 8

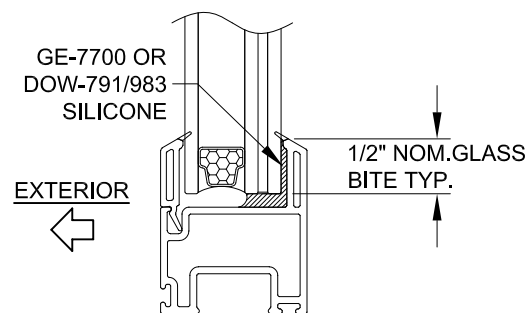

TYP. GLAZING DETAIL

PVB INTERLAYER MANUFACTURED BY KURARAY AMERICA, INC.

PGT

1070 TECHNOLOGY DRIVE
N. VENICE, FL 34275
(941)-480-1600

Series	HR-5510	Scale	NTS	Sheet	2 OF 4	DWG No.	TDI-HR5510.1	Rev. No.	A
Desc.	VINYL HR WINDOW TDI (IMP.-RESIST.)		Date	3/17/15		Drawn By	J ROSOWSKI		
Rev 1	UPDATED CODE & ANCHORS - JR		Rev 1 Date	6/25/21		Rev 2			

COPYRIGHT © 2021
PGT INDUSTRIES, INC.
LIMITED LICENSE TO MAKE
COPIES FOR PERMITTING.

STATE OF TEXAS

ANTHONY LYNN MILLER
106954
LICENSED PROFESSIONAL ENGINEER

A Lynn Miller 7/16/21
A. LYNN MILLER, P.E.
P.E.# 106954

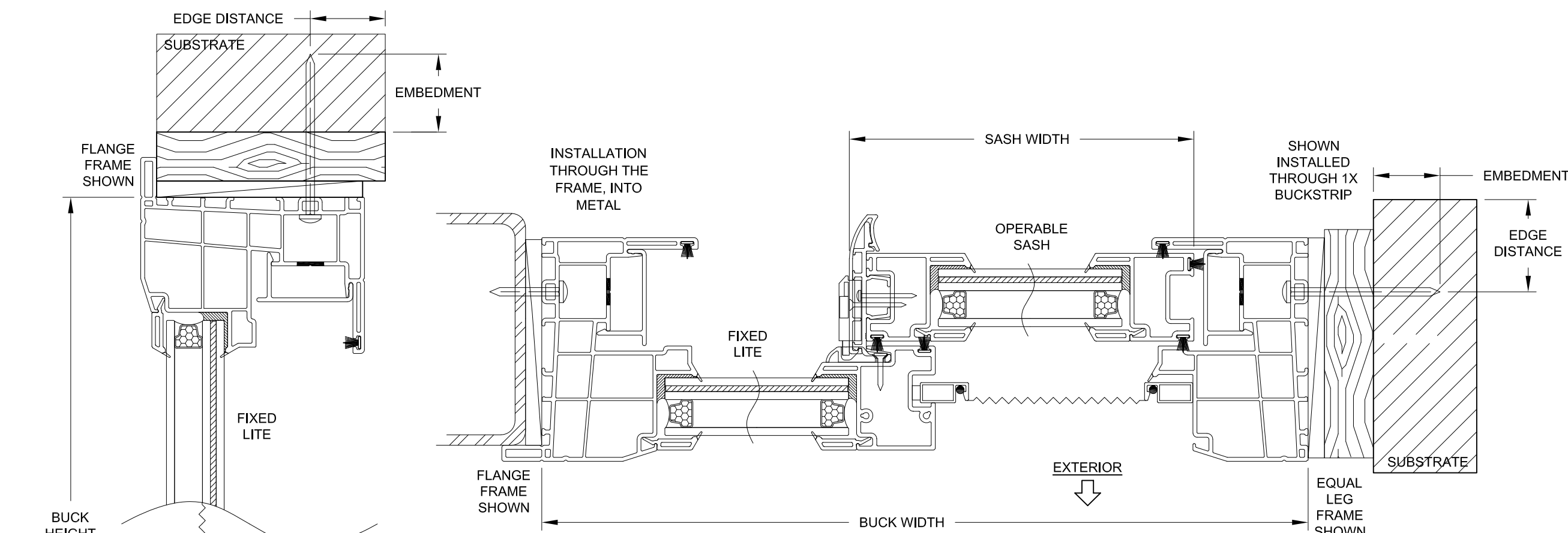

HORIZONTAL SECTION A-A (XO)
(OX & XOX SIMILAR)

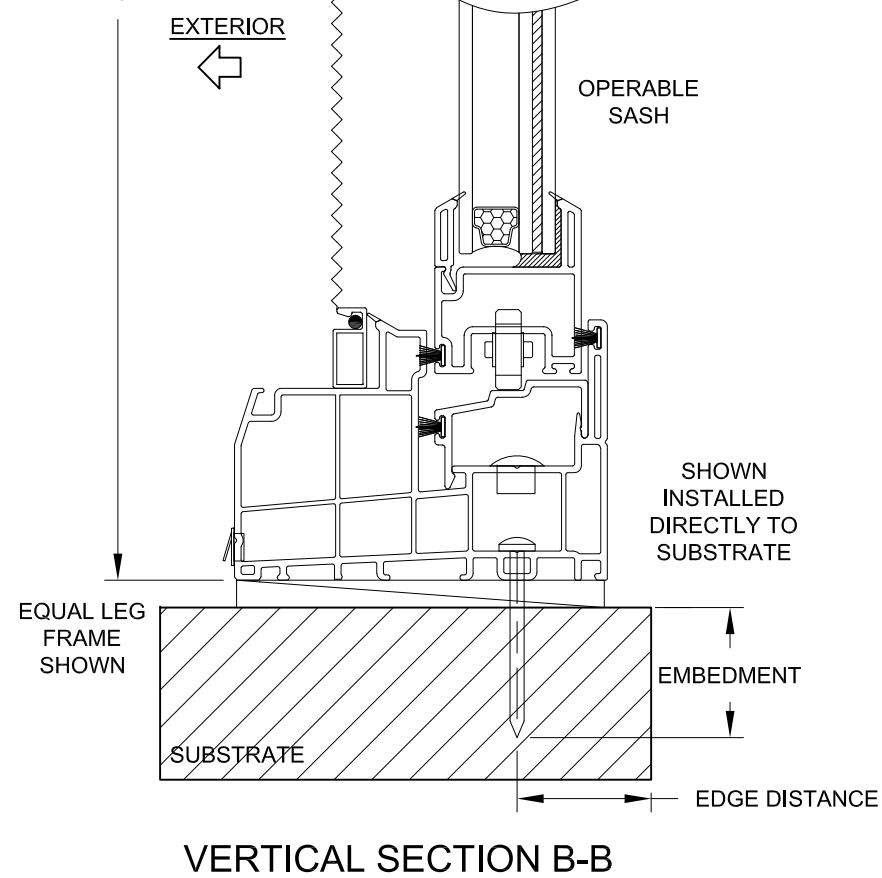

VERTICAL SECTION B-B

- INSTALLATION NOTES:**
- 1) SEE SHEET 1 FOR SPACING REQUIREMENTS.
 - 2) SEE TABLE(S) ON SHEET 2 FOR ANCHORAGE AND SUBSTRATE REQUIREMENTS.
 - 3) MAX. SHIM THICKNESS TO BE 1/4".
 - 4) GLASS SHOWN IS FOR ILLUSTRATIVE PURPOSES ONLY AND MAY DIFFER TO MEET DESIGN REQUIREMENTS.
 - 5) FIN AND/OR FLANGE MAY BE REMOVED TO CREATE OTHER FRAME TYPES.

COPYRIGHT © 2021
PGT INDUSTRIES, INC.
LIMITED LICENSE TO MAKE
COPIES FOR PERMITTING.



1070 TECHNOLOGY DRIVE
N. VENICE, FL 34275
(941)-480-1600

Series	HR-5510	Scale	NTS	Sheet	3 OF 4	DWG No.	TDI-HR5510.1	Rev. No.	A
Desc.	VINYL HR WINDOW TDI (IMP.-RESIST.)		Date	3/17/15					
Rev 1	FLANGE & EQUAL-LEG/BOX FRAMES		Drawn By	J ROSOWSKI					
Rev 2	UPDATED CODE & ANCHORS - JR		Rev 1 Date	6/25/21					



A Lynn Miller 7/16/21
A. LYNN MILLER, P.E.
P.E.# 106954

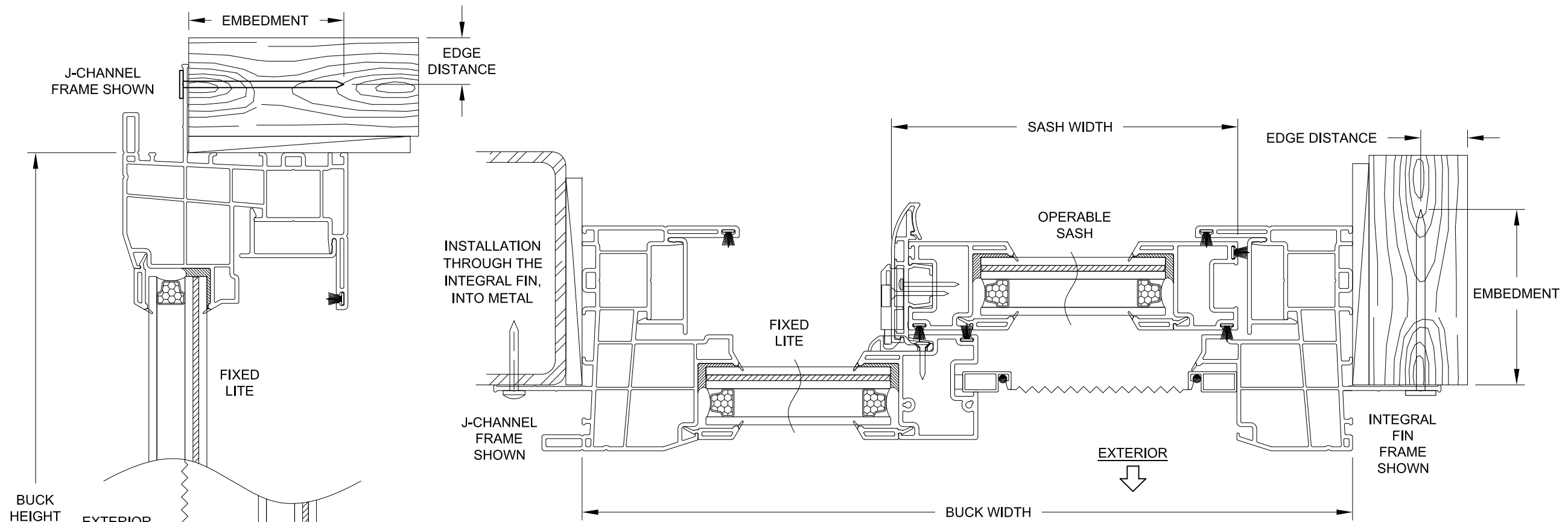

HORIZONTAL SECTION C-C (XO)
(OX & XOX SIMILAR)

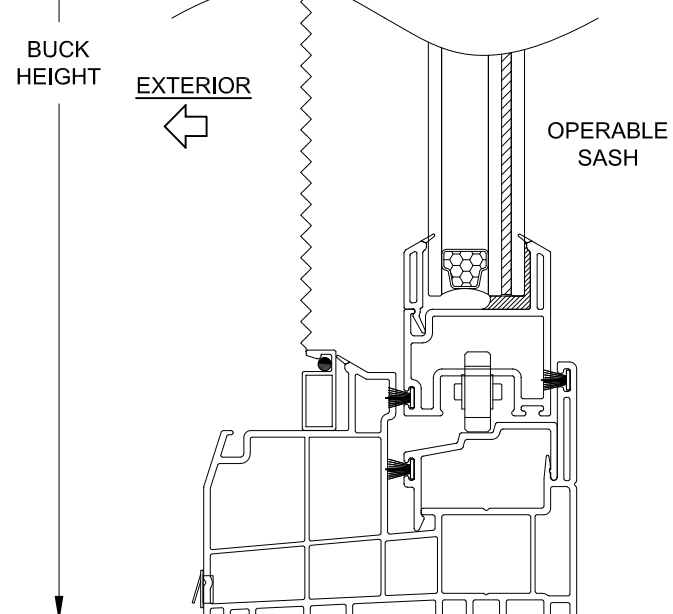

VERTICAL SECTION D-D

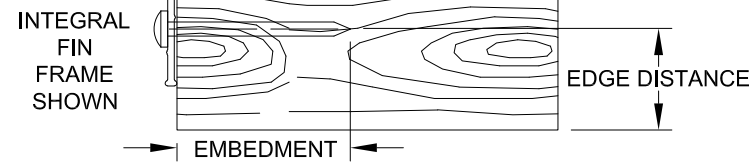

INSTALLATION THROUGH THE INTEGRAL FIN, INTO METAL

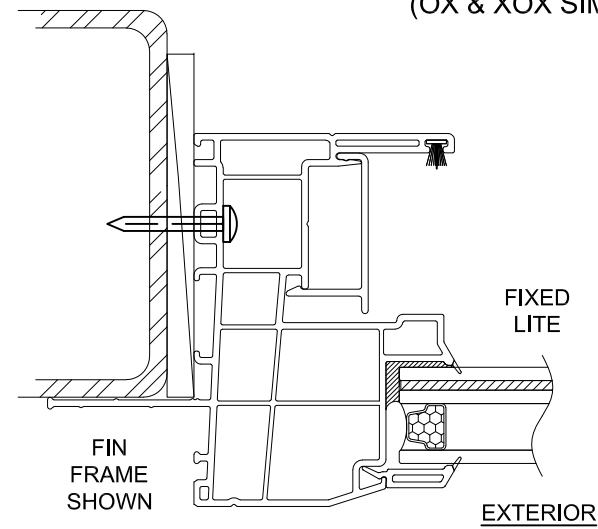

INSTALLATION THROUGH THE FRAME, INTO METAL (JAMB SHOWN, HEAD & SILL SIMILAR)

INSTALLATION NOTES:

- 1) SEE SHEET 1 FOR SPACING REQUIREMENTS.
- 2) SEE TABLE(S) ON SHEET 2 FOR ANCHORAGE AND SUBSTRATE REQUIREMENTS.
- 3) MAX. SHIM THICKNESS TO BE 1/4".
- 4) GLASS SHOWN IS FOR ILLUSTRATIVE PURPOSES ONLY AND MAY DIFFER TO MEET DESIGN REQUIREMENTS.
- 5) FIN AND/OR FLANGE MAY BE REMOVED TO CREATE OTHER FRAME TYPES.

COPYRIGHT © 2021
PGT INDUSTRIES, INC.
LIMITED LICENSE TO MAKE
COPIES FOR PERMITTING.



1070 TECHNOLOGY DRIVE
N. VENICE, FL 34275
(941)-480-1600

Series	HR-5510	Scale	NTS	Sheet	4 OF 4	DWG No.	TDI-HR5510.1	Rev. No.	A
Desc.	VINYL HR WINDOW TDI (IMP.-RESIST.)		Date	3/17/15		J ROSOWSKI			
Rev 1	J-CHANNEL & INTEGRAL FIN FRAMES		Drawn By			6/25/21			
Rev 2	UPDATED CODE & ANCHORS - JR		Rev 1 Date						