

IMPACT RATING	DESIGN PRESSURE RATING
NON-IMPACT RESISTANT	SEE TABLE 1

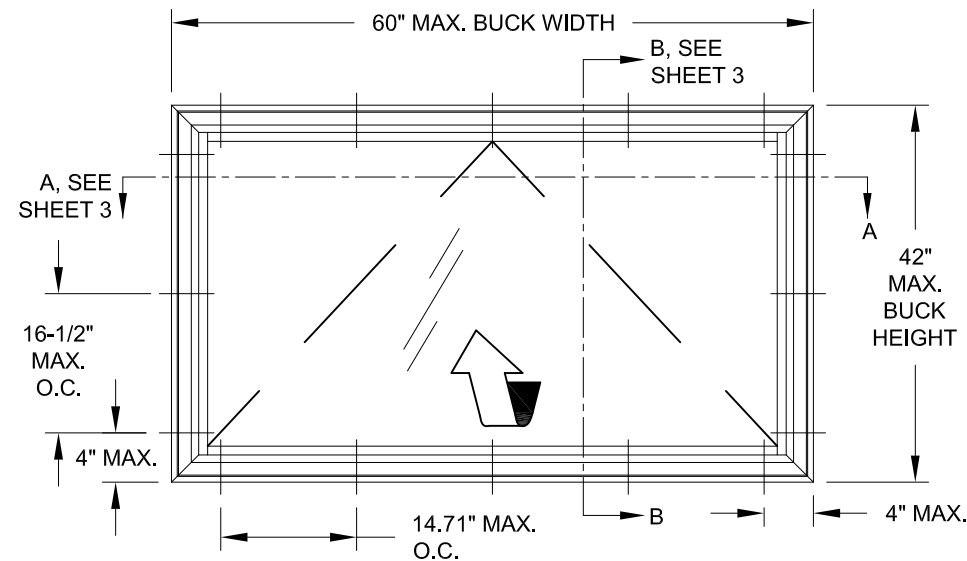

ELEVATION FOR TYP. EQUAL LEG/BOX & FLANGE FRAME

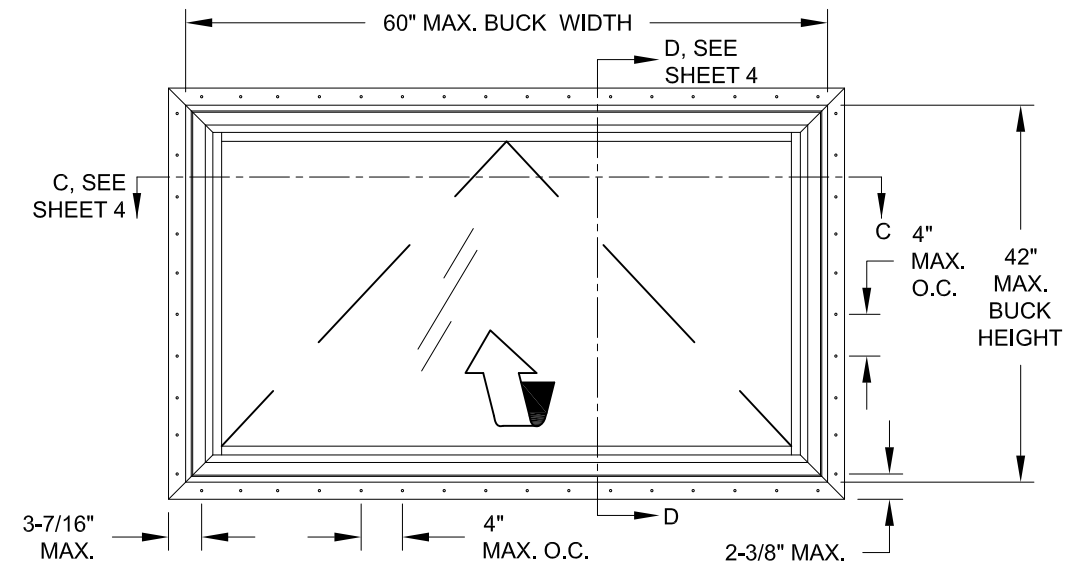

ELEVATION FOR TYP. FIN & J-CHANNEL FRAME

GENERAL NOTES: SERIES 5440 NON-IMPACT RESISTANT, VINYL AWNING WINDOW

1) THIS PRODUCT HAS BEEN DESIGNED & TESTED TO COMPLY WITH THE REQUIREMENTS OF THE 2018 INTERNATIONAL BUILDING CODE (IBC) AND THE 2018 INTERNATIONAL RESIDENTIAL CODE (IRC) FOR THE DESIGN PRESSURES LISTED.

2) ALL WOOD BUCKS LESS THAN 1-1/2" THICK ARE TO BE CONSIDERED 1X INSTALLATIONS. 1X WOOD BUCKS ARE OPTIONAL IF UNIT IS INSTALLED DIRECTLY TO SUBSTRATE. WOOD BUCKS DEPICTED AS 2X ARE 1-1/2" THICK OR GREATER. 1X AND 2X BUCKS (WHEN USED) SHALL BE DESIGNED TO PROPERLY TRANSFER LOADS TO THE STRUCTURE. WOOD BUCK DESIGN AND INSTALLATION IS THE RESPONSIBILITY OF THE ENGINEER, (EOR) OR ARCHITECT OF RECORD, (AOR).

3) ANCHOR EMBEDMENT TO BASE MATERIAL SHALL BE BEYOND WALL DRESSING OR STUCCO. USE ANCHORS OF SUFFICIENT EMBEDMENT. INSTALLATION ANCHORS SHOULD BE SEALED. OVERALL SEALING/FLASHING STRATEGY FOR WATER RESISTANCE OF INSTALLATION SHALL BE DONE BY OTHERS AND IS BEYOND THE SCOPE OF THESE INSTRUCTIONS.

4) MAX. 1/4" SHIMS ARE REQUIRED AT EACH ANCHOR LOCATION WHERE THE PRODUCT IS NOT FLUSH TO THE SUBSTRATE. USE SHIMS CAPABLE OF TRANSFERRING APPLIED LOADS. WOOD BUCKS, BY OTHERS, MUST BE SUFFICIENTLY ANCHORED TO RESIST LOADS IMPOSED ON THEM BY THE WINDOW.

5) THE ANCHORAGE METHODS SHOWN HAVE BEEN DESIGNED TO RESIST THE WINDLOADS CORRESPONDING TO THE REQUIRED DESIGN PRESSURE. THE 33-1/3% STRESS INCREASE HAS NOT BEEN USED IN THE DESIGN OF THIS PRODUCT. THE 1.6 LOAD DURATION FACTOR WAS USED FOR THE EVALUATION OF ANCHORS INTO WOOD. ANCHORS SHALL BE COATED OR CORROSION RESISTANT AS SPECIFIED IN THE IRC/IBC.

TABLE 1:

Window Buck Size		Design Pressure		Certification (CAR) Number
Width	Height	(+) psf	(-) psf	
60"	42"	50	50	190-1063
52.125"	42"	65	70	190-1064

COPYRIGHT © 2021
PGT INDUSTRIES, INC.
LIMITED LICENSE TO MAKE
COPIES FOR PERMITTING.



Series	Rev 1	Desc.	VINYL AWNING WINDOW TDI (NON-IMPACT)	Date	3/20/15
			GENERAL NOTES & ELEVATIONS	Drawn By	J ROSOWSKI
			UPDATED CODE & ANCHORS - JR	Rev 1 Date	8/22/21
				Rev 2 Date	
AW-5440	Scale	NTS	Sheet	1 OF 4	DWG No.
					TDI-AW5440.1
				Rev. No.	A

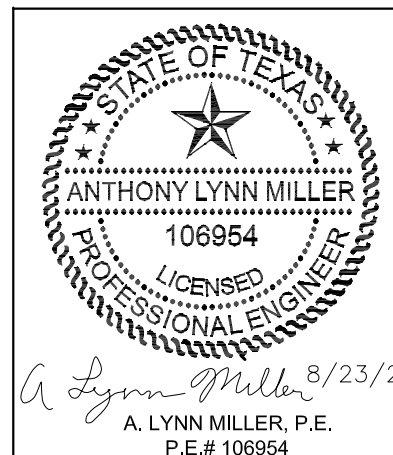

TABLE 2: ANCHORS INSTALLED THROUGH FRAME

Anchor	Substrate	Min. Edge Distance	Min. Embedment
#10 SMS (steel, 18-8 S.S. or 410 S.S.) Max. DP of 50.0	P.T. Southern Pine (SG=0.55)	7/16"	1-3/8"
	Steel, A36	3/8"	0.050"
	Steel Stud, A653 Gr. 33	3/8"	0.0346" (20 Ga.)
	Aluminum, 6063-T5	3/8"	0.050"
#12 SMS (steel, 18-8 S.S. or 410 S.S.)	P.T. Southern Pine (SG=0.55)	9/16"	1-3/8"
	Steel, A36	3/8"	0.050"
	Steel Stud, A653 Gr. 33	3/8"	0.0346" (20 Ga.)
	Aluminum, 6063-T5	3/8"	0.063"
3/16" Ultracon (steel) Max. DP of 50.0	P.T. Southern Pine (SG=0.55)	7/16"	1-3/8"
	Concrete (min. 2.85 ksi)	1"	1-3/8"
	UngROUTED CMU, (ASTM C-90)	2-1/2"	1-1/4"
1/4" Ultracon (steel)	P.T. Southern Pine (SG=0.55)	1"	1-3/8"
	Concrete (min. 2.85 ksi)	1"	1-3/4"
	UngROUTED CMU, (ASTM C-90)	2-1/2"	1-1/4"
	Concrete (min. 2.85 ksi)	2-1/2"	1-3/4"
1/4" Crete-Flex (410 S.S.)	P.T. Southern Pine (SG=0.55)	1"	1-3/8"
	Concrete (min. 3.35 ksi)	1"	1-3/4"
	UngROUTED CMU, (ASTM C-90)	2-1/2"	1-1/4"
	Concrete (min. 3.35 ksi)	2-1/2"	1-3/4"
1/4" Aggre-Gator (18-8 S.S.)	Concrete (min. 3.275 ksi)	1-1/2"	1-3/8"
	P.T. Southern Pine (SG=0.55)	1"	1-3/8"
	UngROUTED CMU, (ASTM C-90)	2"	1-1/4"

TABLE 3: ANCHORS INSTALLED THROUGH INTEGRAL FIN

Anchor	Substrate	Min. Edge Distance	Min. Embedment
2-1/2" x .131" Common Nail Max. DP of 50 psf	P.T. Southern Pine (SG=.55)	9/16"	2-7/16"
	P.T. Southern Pine (SG=.55)	9/16"	2-7/16"
2-1/2" x .131" Ring-shank Nail	P.T. Southern Pine (SG=.55)	9/16"	2-7/16"
2-1/2" x .145" Roofing Nail	P.T. Southern Pine (SG=.55)	9/16"	2-7/16"
#10 SMS (steel, 18-8 S.S. or 410 S.S.)	P.T. Southern Pine (SG=.55)	3/4"	1-3/8"
	Aluminum, 6063-T5	3/8"	0.050"
	Steel Stud, Gr. 33	3/8"	0.0346" (20 Ga.)
	Steel, A36	3/8"	0.050"

ANCHOR NOTES:

- 1) "UNGROUTED CMU" VALUES MAY BE USED FOR GROUTED CMU APPLICATIONS.
- 2) PANHEAD, FLATHEAD OR HEXHEAD ARE ACCEPTABLE.
- 3) ANCHOR LENGTH TO BE SO THAT A MIN. OF 3 THREADS EXTEND BEYOND THE METAL SUBSTRATE.

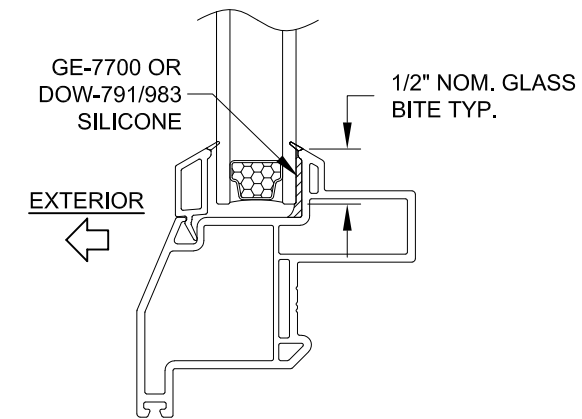

TYP. GLAZING DETAIL

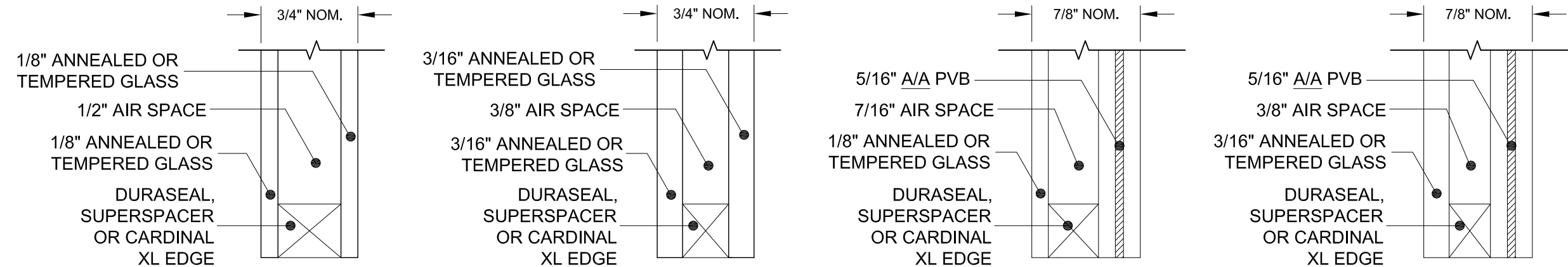

GLAZING TYPES

PVB INTERLAYER MANUFACTURED BY KURARAY AMERICA, INC.

COPYRIGHT © 2021
PGT INDUSTRIES, INC.
LIMITED LICENSE TO MAKE
COPIES FOR PERMITTING.



1070 TECHNOLOGY DRIVE
N. VENICE, FL 34275
(941)-480-1600

Series	Rev 1	Desc.	VINYL AWNING WINDOW TDI (NON-IMPACT)	Date	3/20/15
			GLASS/ANCHOR OPTIONS	Drawn By	J ROSOWSKI
	Rev 1		UPDATED CODE & ANCHORS - JR	Date	8/22/21
	Rev 2			Date	
AW-5440	Scale	NTS	Sheet	2 OF 4	DWG No.
					TDI-AW5440.1
				Rev. No.	A



A Lynn Miller 8/23/21
A. LYNN MILLER, P.E.
P.E.# 106954

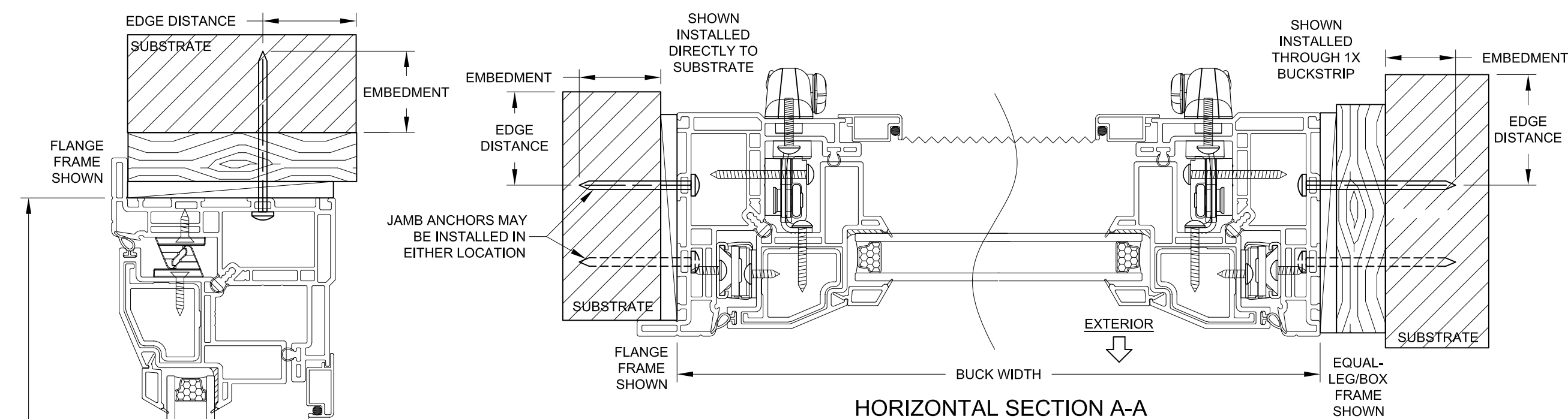

HORIZONTAL SECTION A-A

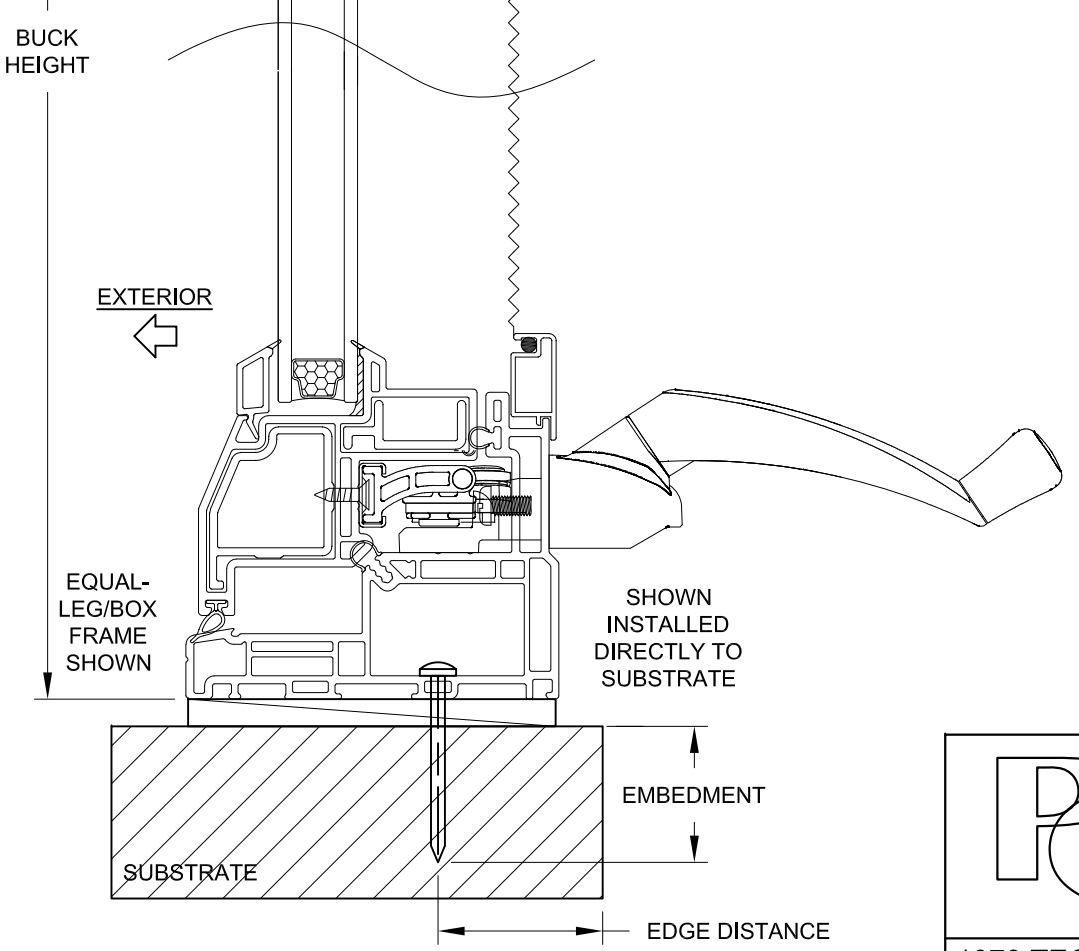

VERTICAL SECTION B-B

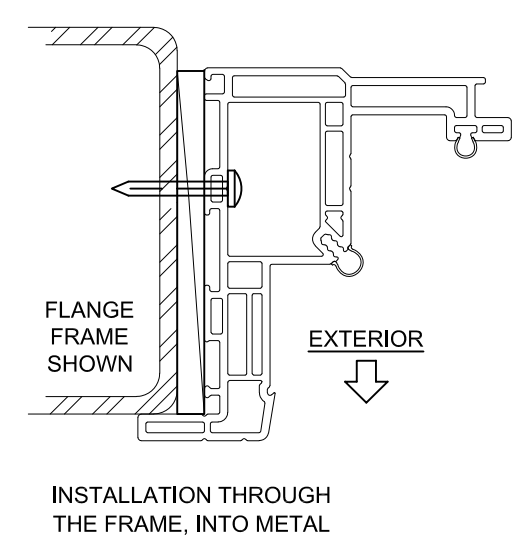

INSTALLATION NOTES:

- 1) SEE SHEET 1 FOR SPACING REQUIREMENTS.
- 2) SEE TABLE(S) ON SHEET 2 FOR ANCHORAGE AND SUBSTRATE REQUIREMENTS.
- 3) MAX. SHIM THICKNESS TO BE 1/4".
- 4) GLASS SHOWN IS FOR ILLUSTRATIVE PURPOSES ONLY AND MAY DIFFER TO MEET DESIGN REQUIREMENTS.
- 5) FIN AND/OR FLANGE MAY BE REMOVED TO CREATE OTHER FRAME TYPES.

COPYRIGHT © 2021
PGT INDUSTRIES, INC.
LIMITED LICENSE TO MAKE
COPIES FOR PERMITTING.

1070 TECHNOLOGY DRIVE
N. VENICE, FL 34275
(941)-480-1600

Series	Rev 1	Desc.	Title	Date
		VINYL AWNING WINDOW TDI (NON-IMPACT)		3/20/15
		FLANGE & EQUAL-LEG/BOX FRAMES	Drawn By	J ROSOWSKI
		UPDATED CODE & ANCHORS - JR	Rev 1 Date	8/22/21
			Rev 2 Date	
AW-5440	Scale	NTS	Sheet	3 OF 4
	DWG No.	TDI-AW5440.1	Rev. No.	A

ANTHONY LYNN MILLER
106954
LICENSED PROFESSIONAL ENGINEER
A Lynn Miller 8/23/21
A. LYNN MILLER, P.E.
P.E.# 106954

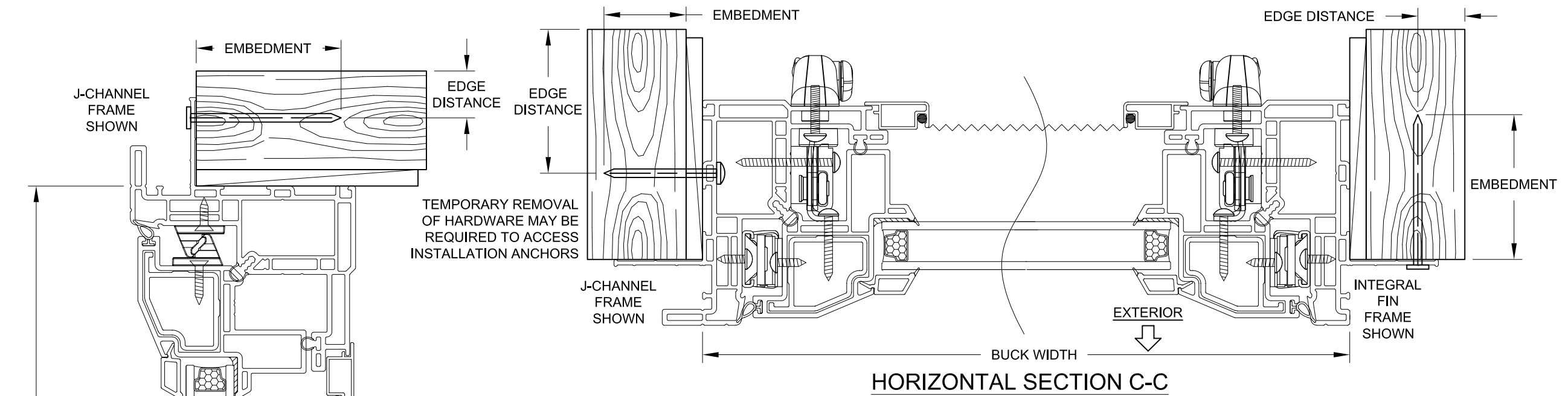

HORIZONTAL SECTION C-C

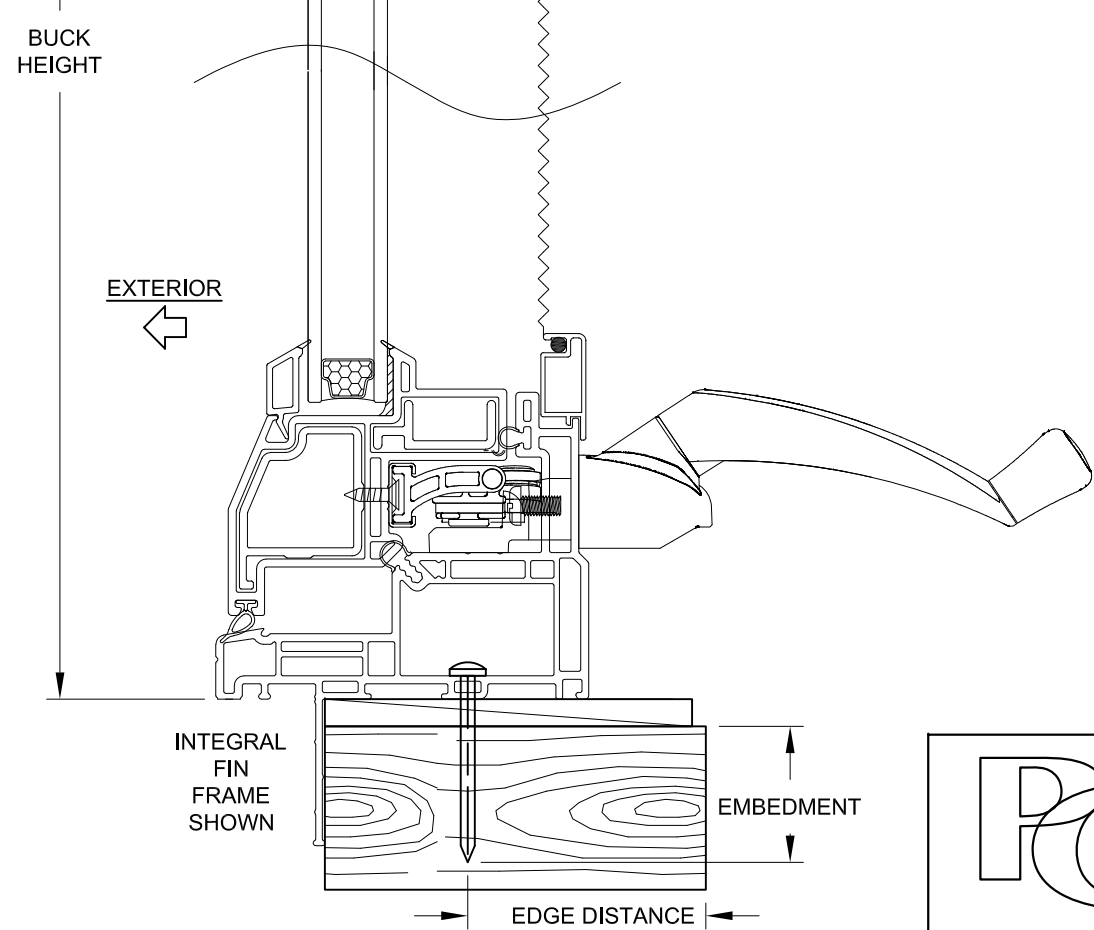

VERTICAL SECTION D-D

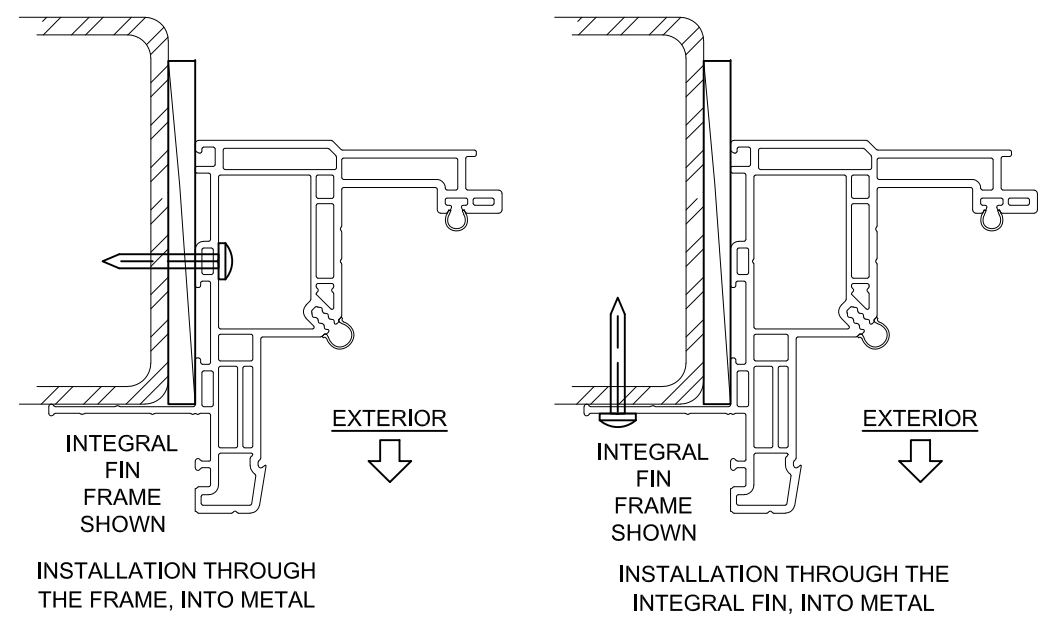

INSTALLATION NOTES:

- 1) SEE SHEET 1 FOR SPACING REQUIREMENTS.
- 2) SEE TABLE(S) ON SHEET 2 FOR ANCHORAGE AND SUBSTRATE REQUIREMENTS.
- 3) MAX. SHIM THICKNESS TO BE 1/4".
- 4) GLASS SHOWN IS FOR ILLUSTRATIVE PURPOSES ONLY AND MAY DIFFER TO MEET DESIGN REQUIREMENTS.
- 5) FIN AND/OR FLANGE MAY BE REMOVED TO CREATE OTHER FRAME TYPES.

COPYRIGHT © 2021
PGT INDUSTRIES, INC.
LIMITED LICENSE TO MAKE
COPIES FOR PERMITTING.

1070 TECHNOLOGY DRIVE
N. VENICE, FL 34275
(941)-480-1600

Series	Rev 1	Title	VINYL AWNING WINDOW TDI (NON-IMPACT)	Date	3/20/15
	Rev 2	Desc.	J-CHANNEL & INTEGRAL FIN FRAMES	Drawn By	J ROSOWSKI
			UPDATED CODE & ANCHORS - JR	Rev 1 Date	8/22/21
				Rev 2 Date	
AW-5440	Scale	NTS	Sheet	4 OF 4	DWG No.
					TDI-AW5440.1
				Rev. No.	A

ANTHONY LYNN MILLER
106954
LICENSED PROFESSIONAL ENGINEER
A Lynn Miller 8/23/21
A. LYNN MILLER, P.E.
P.E.# 106954