







R:\A - Projects\Project Folders\Proj 1201-1300\pf 1273\Texas 3001\TX-4413.dwg, 4.

BILL OF MATERIALS		
ITEM #	DESCRIPTION	MATERIAL
B	2X FRAMING (SG >= 0.42)	WOOD
C	1/4" MAX. SHIM SPACE	-
F	#8 X 2-1/2" PH WOOD SCREW	STEEL
1	EXTRUDED VINYL HEAD AND JAMB *	RIGID PVC
2	EXTRUDED VINYL SILL*	RIGID PVC
3	EXTRUDED VINYL LOCK RAIL (SMALL) *	RIGID PVC
3A	EXTRUDED VINYL LOCK RAIL (MEDIUM) *	RIGID PVC
4	EXTRUDED VINYL MEETING RAIL*	RIGID PVC
5	EXTRUDED VINYL SASH STILE (SMALL) *	RIGID PVC
5A	EXTRUDED VINYL SASH STILE (MEDIUM) *	RIGID PVC
7	EXTRUDED VINYL HEAD INSERT *	RIGID PVC
8	EXTRUDED VINYL BOTTOM LIFT RAIL (SMALL) *	RIGID PVC
8A	EXTRUDED VINYL SASH STILE (MEDIUM) *	RIGID PVC
9	EXTRUDED VINYL TOP PULL RAIL *	RIGID PVC
10	BALANCE COVER	-
12	GLAZING BEAD*	RIGID PVC
14	REINFORCEMENT - MEETING RAIL	STEEL
15	REINFORCEMENT - LOCK RAIL	STEEL
16	REINFORCEMENT - SM. STILES	STEEL
17	REINFORCEMENT - MED. STILES	STEEL
18	WEATHERSTRIP (FIN PILE)	-
19	WEATHERSTRIP (VINYL BULB)	VINYL
20	CAM LOCK	STEEL

\* THE APPROVED WHITE RIGID PVC EXTERIOR EXTRUSIONS FOR WINDOWS ARE TO BE PRODUCED BY EXTRUDERS LICENSEES IN "AAMA CERTIFICATION PROGRAMS FOR RIGID PVC EXTRUSIONS".

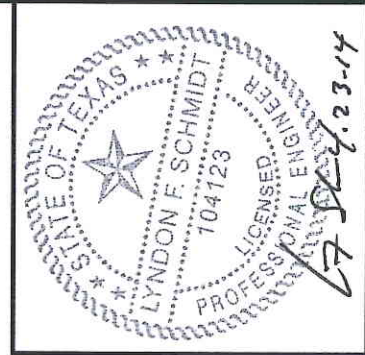

Documents Prepared By: Lyndon F. Schmidt, P.E.  
TEXAS P.E. #104123

**RW** BUILDING CONSULTANTS, INC.  
P.O. Box 230 Valrico FL, 33595  
Phone No.: 813.659.9197

TEXAS BOARD OF PROFESSIONAL ENGINEERS  
CERTIFICATE OF REGISTRATION # F-11852

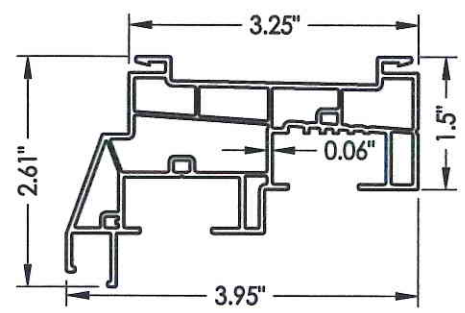

1 HEAD & JAMB

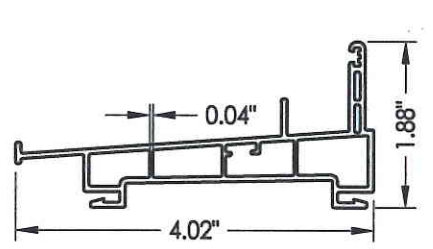

2 SILL

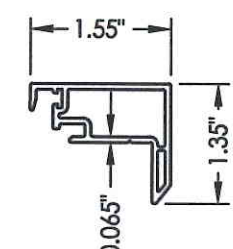

3 LOCK RAIL Small

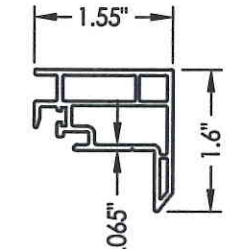

3A LOCK RAIL Medium

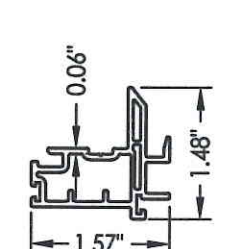

4 MEETING RAIL

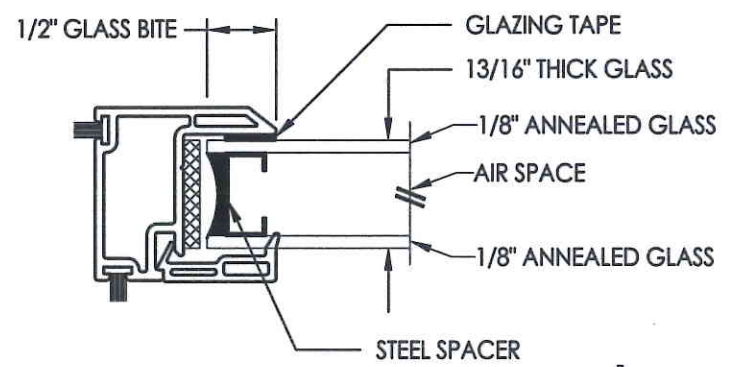

G1 GLAZING DETAIL

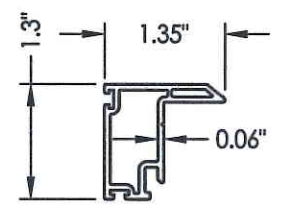

5 SASH STILE Small

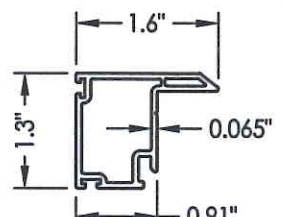

5A SASH STILE Medium

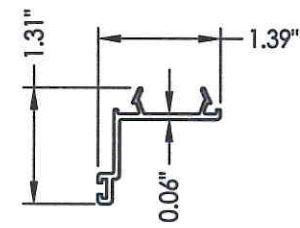

7 HEAD INSERT

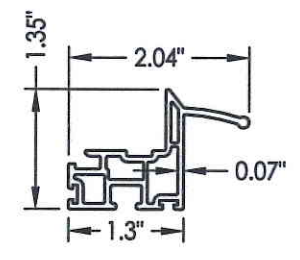

8 BOTTOM LIFT RAIL Small

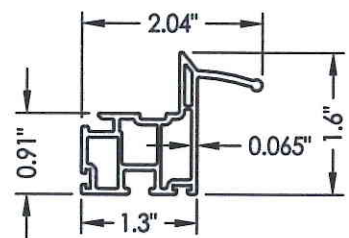

8A BOTTOM LIFT RAIL Medium

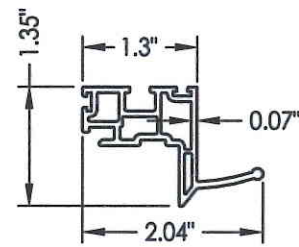

9 TOP PULL RAIL

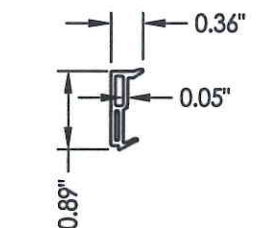

12 GLAZING BEAD

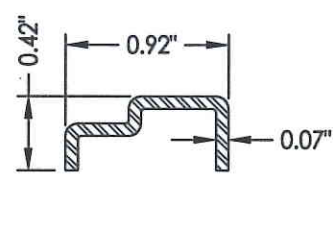

14 REINFORCEMENT Meeting Rail

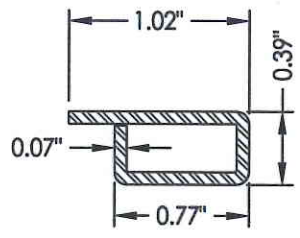

15 REINFORCEMENT Lock Rail

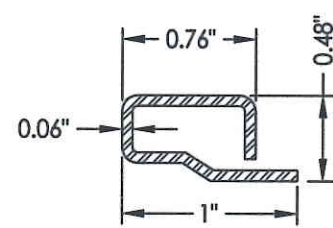

16 REINFORCEMENT SM Stiles

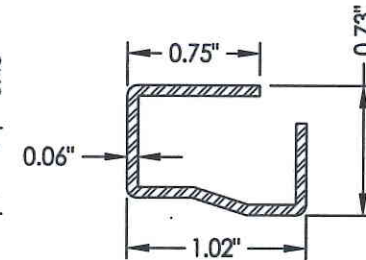

17 REINFORCEMENT MED Stiles

PRODUCT: DOUBLE HUNG WINDOW	
PART OR ASSEMBLY: BILL OF MATERIALS, COMPONENTS & GLAZING DETAIL	
NO.	DATE
BY	REVISIONS
DATE: 3/27/14	
SCALE: N.T.S.	
DWG. BY: JK	
CHK. BY: LFS	
DRAWING NO.: TX-4413	
SHEET 4 OF 4	

© 2014 R.W. BUILDING CONSULTANTS INC.