

WINCORE™

WINDOWS & DOORS

250 Staunton Turnpike, Parkersburg, WV 26104

400 SERIES

Vinyl Horizontal Sliding Window w/ Nailing Fin "NON-IMPACT"

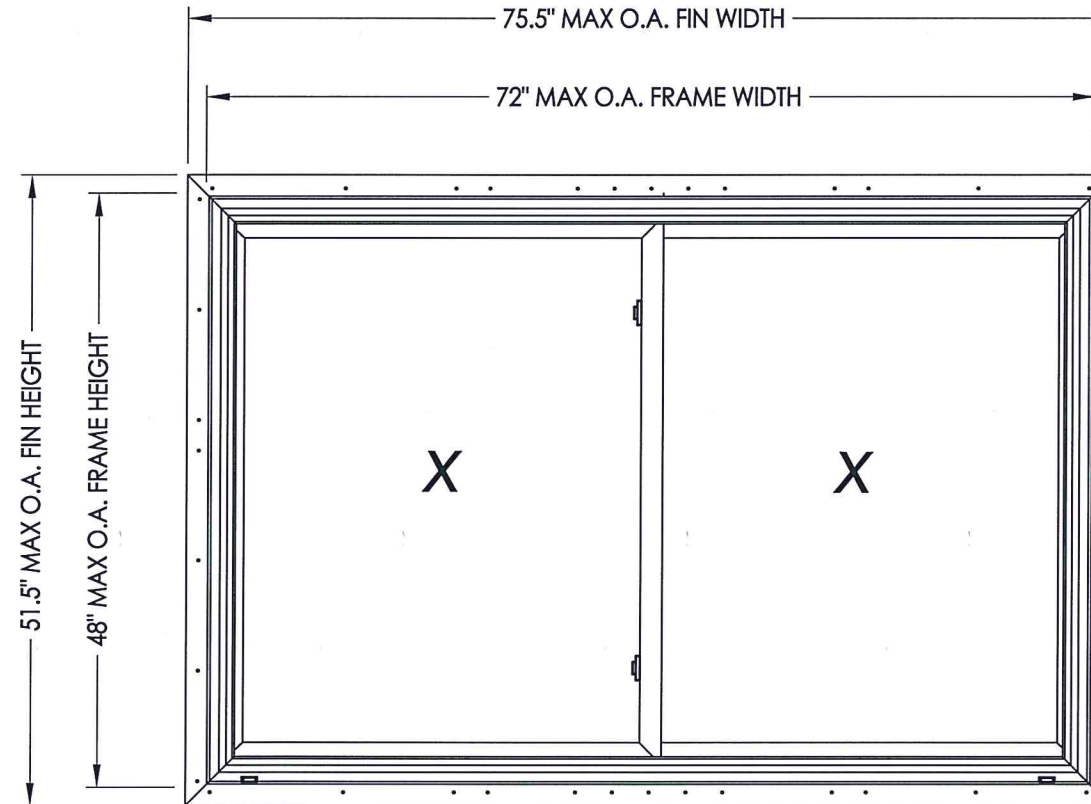

EVALUATED FOR USE IN THE STATE OF TEXAS

TDI WIN-1933

The Wincore Horizontal Sliding Window described herein complies with the 2018 International Residential Code (IRC), Sections R301 & R609 and the 2018 International Building Code (IBC), Sections 1404.13, 1609, 1709.5, 2403 and 2404 subject to the following conditions:

1. Anchors shall be as listed and spaced as shown in the details. Anchor embedment to base material shall be beyond wall dressing or stucco.
2. When used in areas requiring wind-borne debris protection this product is required to be protected with an impact resistant covering that complies with Section R301.2.1.2 of the IRC and Section 1609.1.2 of the IBC.
3. Allowable design pressure requirements must be equal to or less than the design pressure rating shown in the design pressure chart, sheet 1 of this drawing.
4. Conditions not covered by this drawing are subject to further engineering analysis.

TABLE OF CONTENTS	
SHEET#	DESCRIPTION
1	Typical elevations, design pressures and general notes
2	Horizontal & vertical cross sections & frame anchoring
3	Bill of materials, components & glazing details

MAX. FIN DIMENSION	MAX. FRAME DIMENSION	MAX. D.L.O. DIMENSION	GLASS TYPE	DESIGN PRESSURE (PSF)	
				POSITIVE	NEGATIVE
66.5" X 47.5"	63.0" X 44.0"	27.63" X 37.06"	G2	+25.0	-25.0
75.5" X 51.5"	72.0" X 48.0"	32.13" X 41.06"	G1	+30.0	-30.0

** Meeting stile reinforcement is not required



Documents Prepared By: Lyndon F. Schmidt, P.E.
TEXAS P.E. #104123

RW BUILDING CONSULTANTS, INC.
P.O. Box 230 Valrico FL 33595
Phone No.: 813.659.9197
TEXAS BOARD OF PROFESSIONAL ENGINEERS
CERTIFICATE OF REGISTRATION # F-11852

PRODUCT: 400 SERIES
PART OR ASSEMBLY: TYPICAL ELEVATION, DESIGN PRESSURES & GENERAL NOTES

NO.	DATE	REVISIONS
1	1/21/20	UPDATE TO 2018 IBC/IRC

DATE: 11/4/13
SCALE: N.T.S.
DWG. BY: JK
CHK. BY: LFS
DRAWING NO.: TX-4400
SHEET 1 OF 3

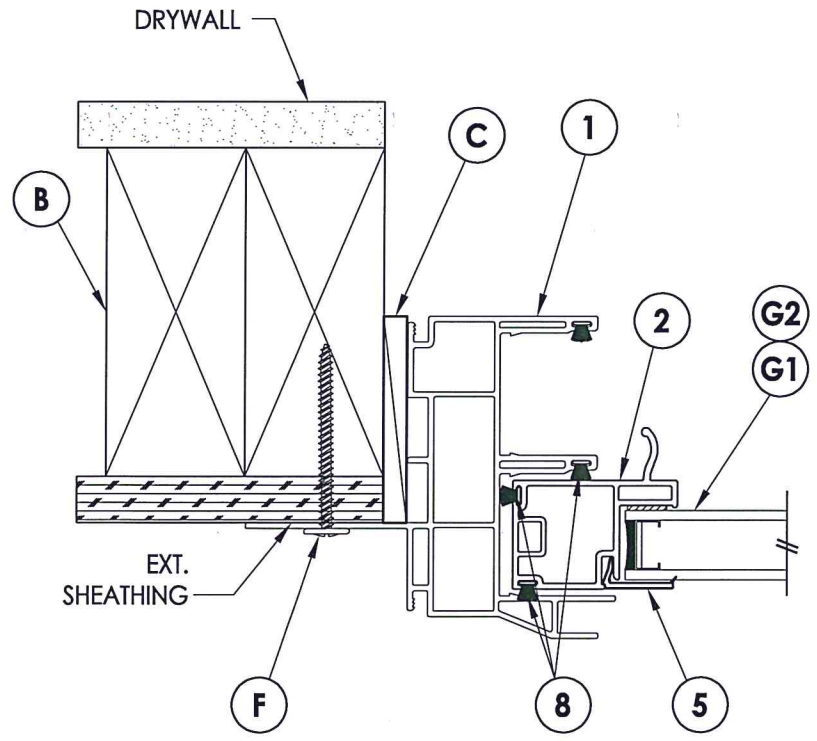
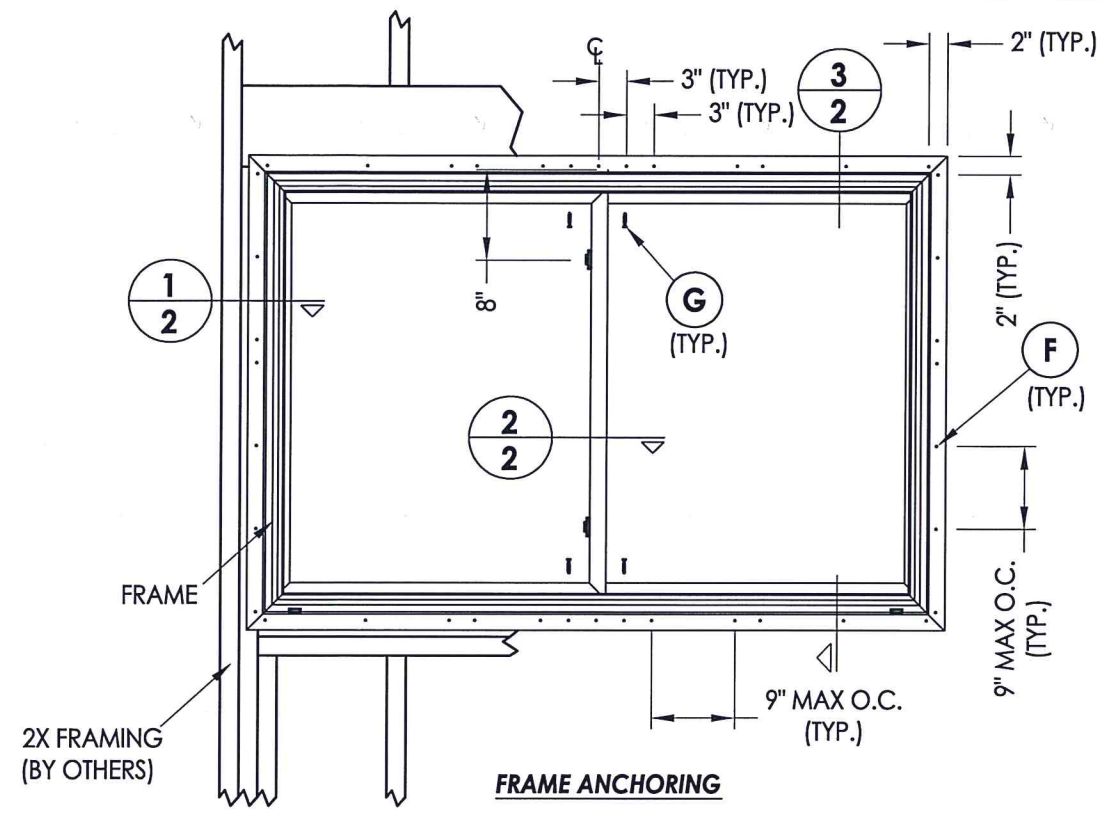

1
2 HORIZONTAL CROSS SECTION

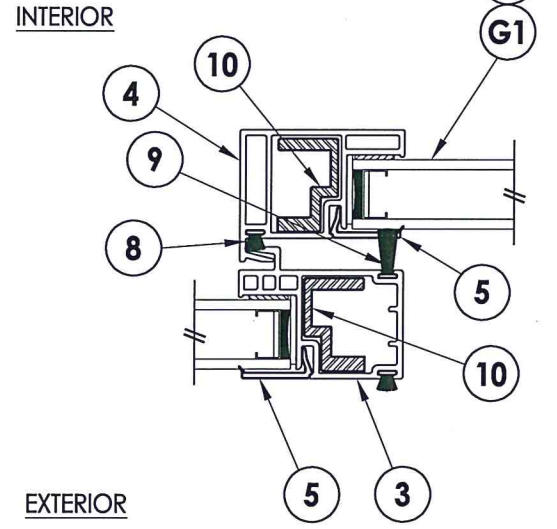

2
2 HORIZONTAL CROSS SECTION

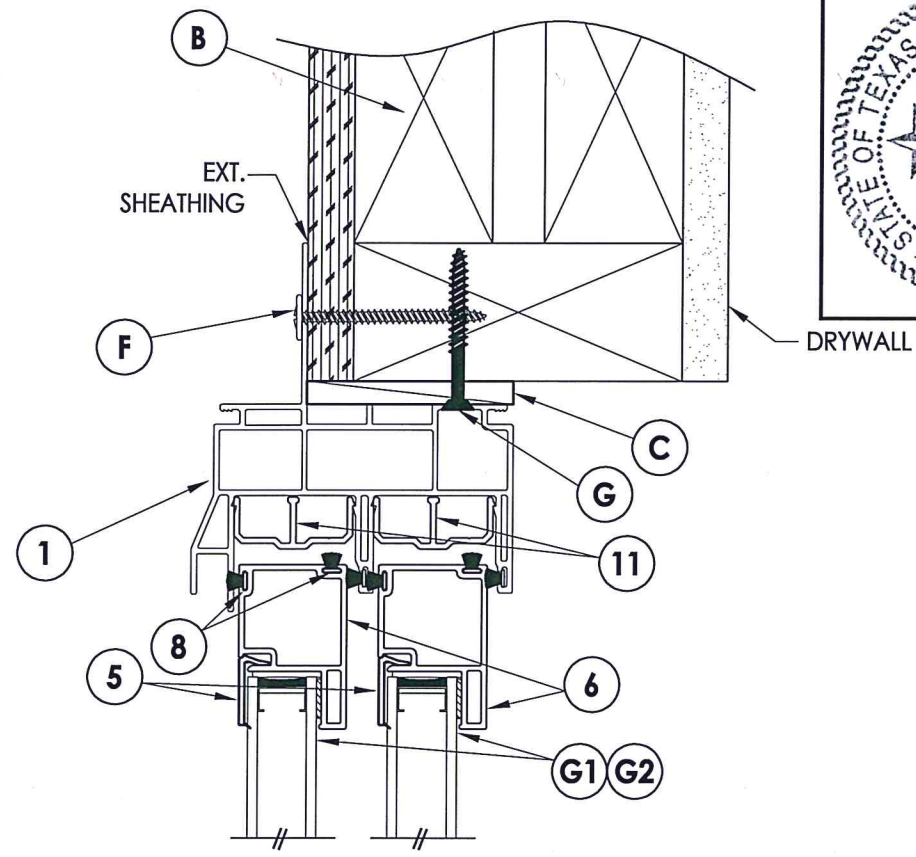

3
2 VERTICAL CROSS SECTION

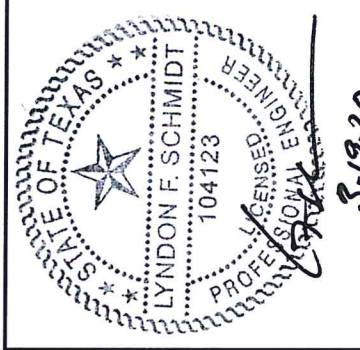

Documents Prepared By: Lyndon F. Schmidt, P.E.
TEXAS P.E. #104123

RW BUILDING CONSULTANTS, INC.
P.O. Box 230 Valrico FL 33595
Phone No.: 813.659.9197

TEXAS BOARD OF PROFESSIONAL ENGINEERS
CERTIFICATE OF REGISTRATION # F-11852

PRODUCT: 400 SERIES

PART OR ASSEMBLY: HORIZONTAL & VERTICAL CROSS SECTIONS & FRAME ANCHORING

NO.	DATE	REVISIONS
1	1/21/20	UPDATE TO 2018 IBC/IRC

DATE: 11/4/13

SCALE: N.T.S.

DWG. BY: JK

CHK. BY: LFS

DRAWING NO.: TX-4400

SHEET 2 OF 3

BILL OF MATERIALS

ITEM #	DESCRIPTION	MATERIAL
B	2X FRAMING (SG >= 0.42)	WOOD
C	1/4" MAX. SHIM SPACE	-
F	#8 X 2" MODIFIED TRUSS HEAD (7/16" Ø) SMS (1-3/8" MIN. EMBEDMENT)	STEEL
G	#10 X 1-1/2" PFH WOOD SCREW (1-3/8" MIN. EMBEDMENT)	STEEL
1	FRAME (500 SERIES - "J" CHANNEL)*	PVC
2	SLIDER PULL STILE*	PVC
3	LOCK STILE*	PVC
4	KEEPER STILE*	PVC
5	GLAZING BEAD*	PVC
6	SLIDER COMMON RAIL*	PVC
7	METAL ROLLERS w/ PLASTIC HOUSING	-
8	WEATHERSTRIP (0.230")	-
9	WEATHERSTRIP (0.380")	-
10	REINFORCEMENT	ALUM
11	SILL TRACK*	PVC
15	WEEPHOLE CAP*	PVC

* THE APPROVED WHITE RIGID PVC EXTERIOR EXTRUSIONS FOR WINDOWS ARE TO BE PRODUCED BY EXTRUDERS LICENSEES IN "AAMA CERTIFICATION PROGRAMS FOR RIGID PVC EXTRUSIONS".

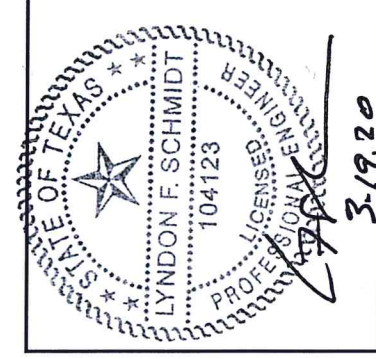

Documents Prepared By: Lyndon F. Schmidt, P.E.
TEXAS P.E. #104123

RW BUILDING CONSULTANTS, INC.
P.O. Box 230 Valrico FL, 33595
Phone No.: 813.659.9197

TEXAS BOARD OF PROFESSIONAL ENGINEERS
CERTIFICATE OF REGISTRATION # F-11852

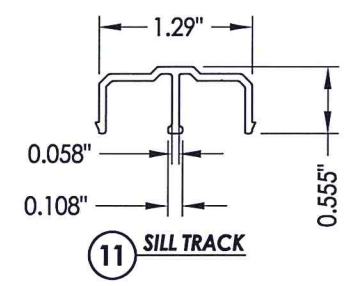
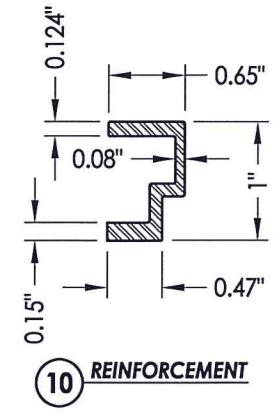
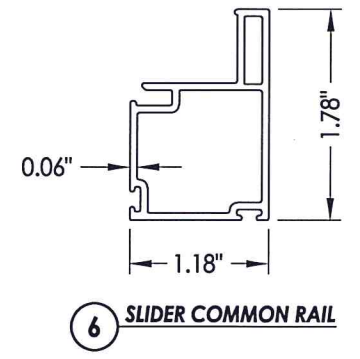
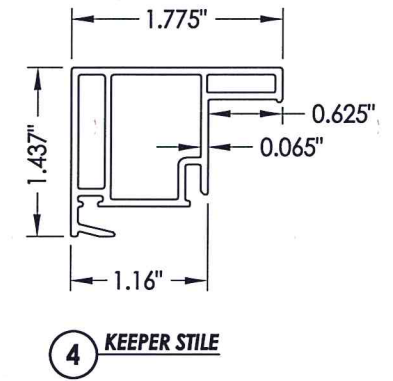
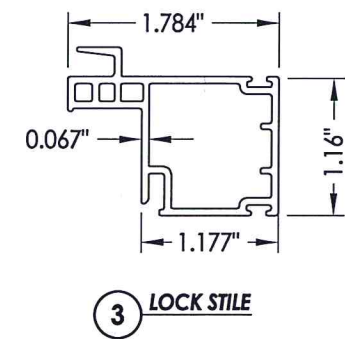
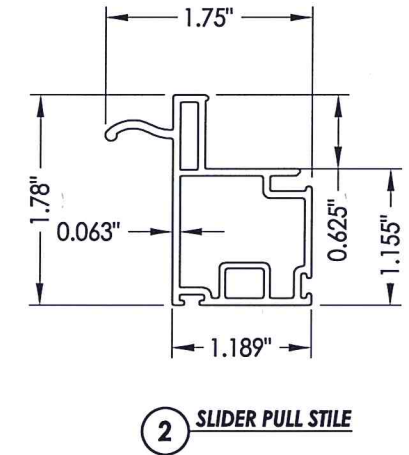
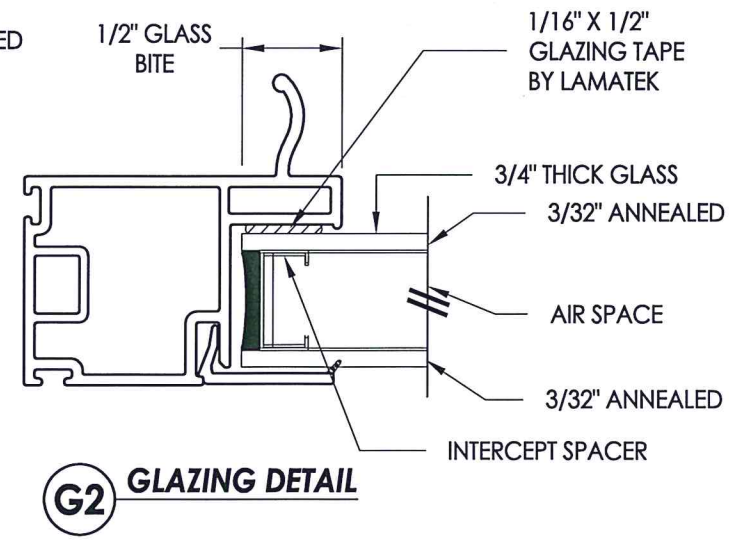
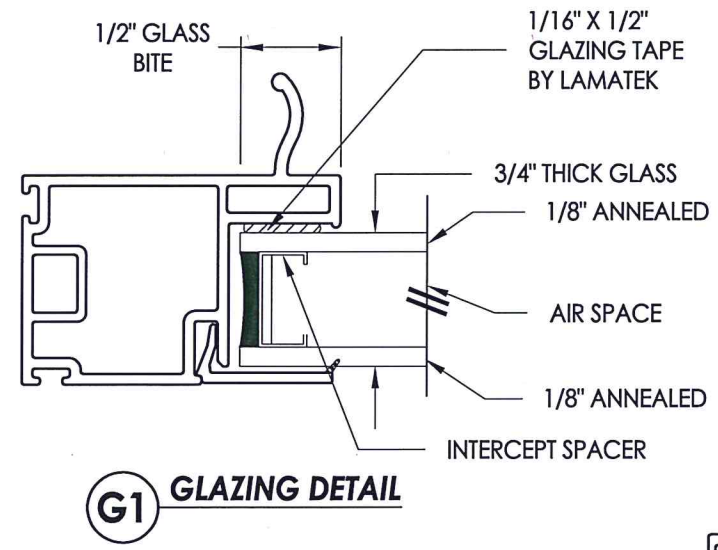
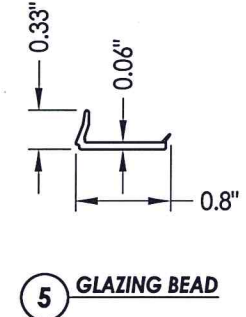
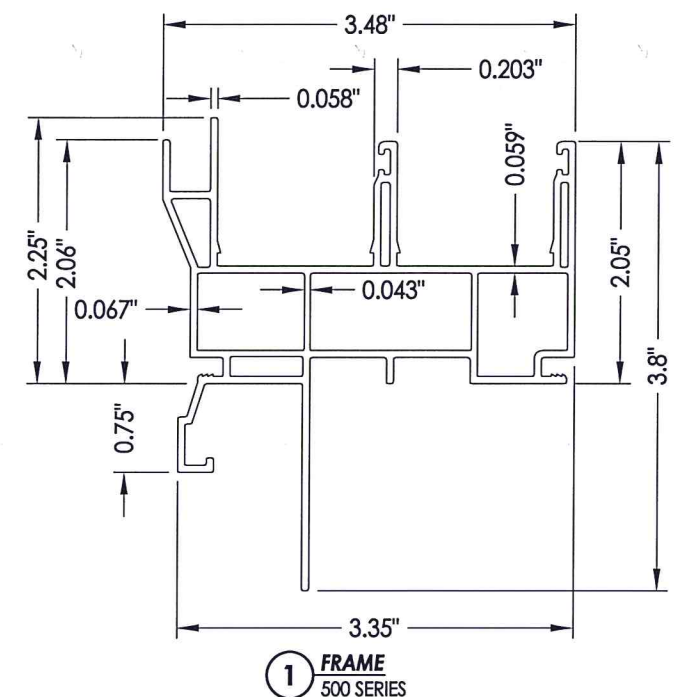

PRODUCT:	400 SERIES	
PART OR ASSEMBLY:	BILL OF MATERIALS, COMPONENTS & GLAZING DETAILS	
NO.	DATE	BY
1	1/21/20	LFS
UPDATE TO 2018 IBC/IRC REVISIONS		
DATE:	11/4/13	
SCALE:	N.T.S.	
DWG. BY:	JK	
CHK. BY:	LFS	
DRAWING NO.:	TX-4400	
SHEET	3 OF 3	