

FRAME ANCHORING

2x framing to be designed by the engineer or architect of record based on wind loads and the cladding being used (typ.).

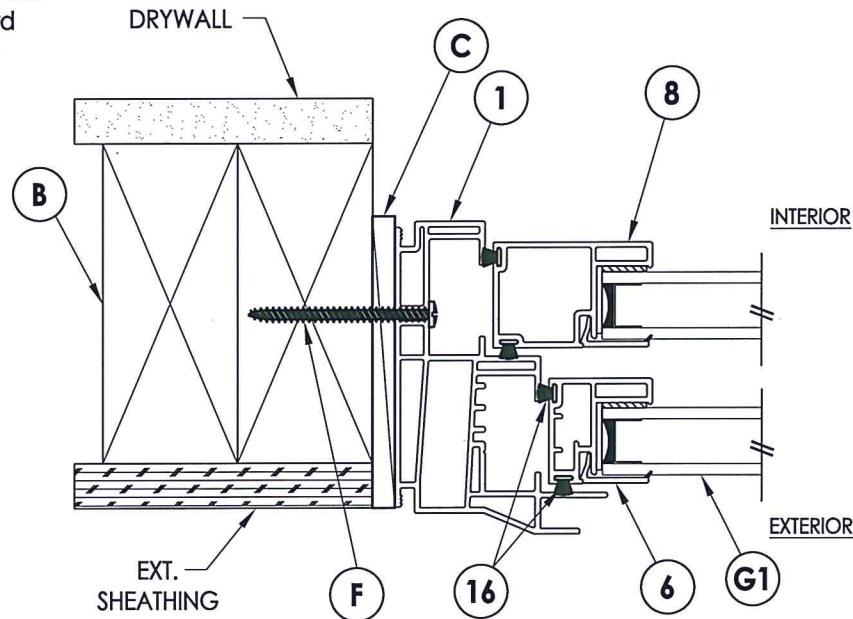

1 HORIZONTAL CROSS SECTION

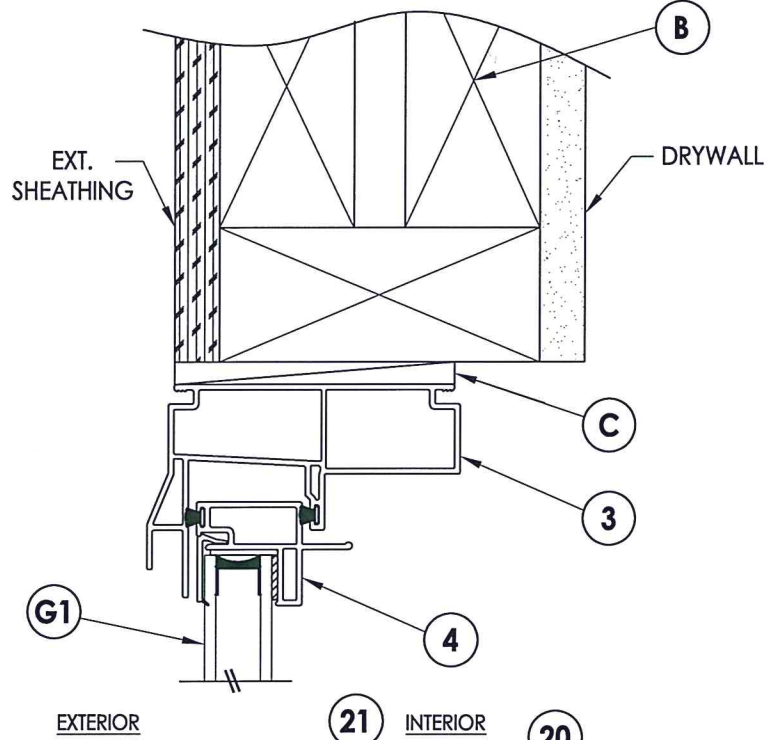

2 VERTICAL CROSS SECTION

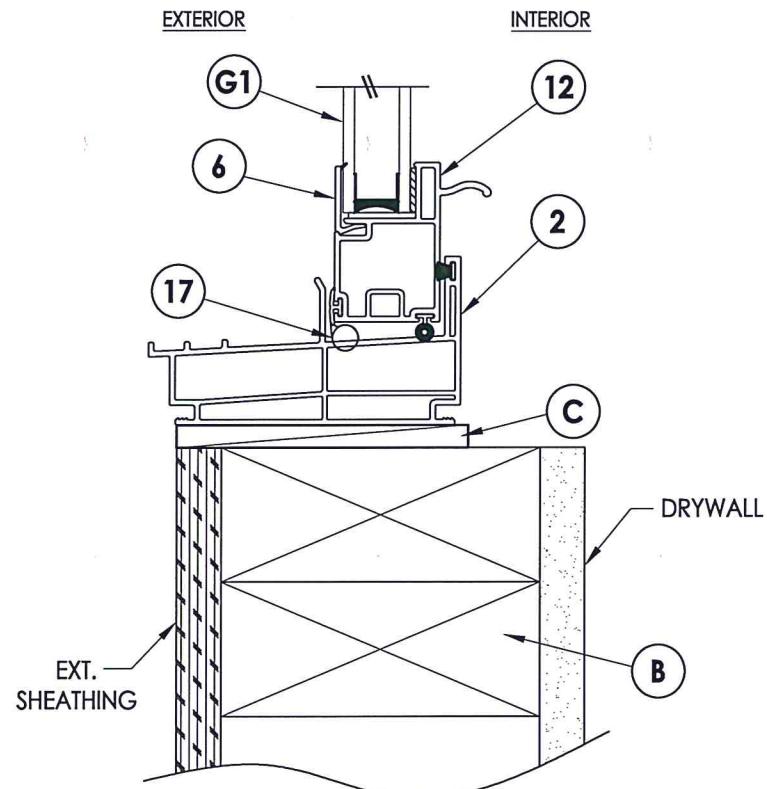

3 VERTICAL CROSS SECTION



Documents Prepared By: Lyndon F. Schmidt, P.E.
TEXAS P.E. #104123

R.W. BUILDING CONSULTANTS, INC.
P.O. Box 230 Valrico FL 33595
Phone No.: 813.659.9197

TEXAS BOARD OF PROFESSIONAL ENGINEERS
CERTIFICATE OF REGISTRATION # F-11852

PRODUCT: 5400/5400S SERIES
Vinyl Double Hung Window

PART OR ASSEMBLY:
CROSS SECTIONS
& FRAME ANCHORING

NO.	DATE	BY	REVISIONS
1	1/16/20	LFS	UPDATE TO 2018 IBC/IRC

DATE: 9/09/14
SCALE: N.T.S.
DWG. BY: JK
CHK. BY: LFS
DRAWING NO.: TX-4472
SHEET 2 of 3

BILL OF MATERIALS		
ITEM #	DESCRIPTION	MATERIAL
B	2X FRAMING (SG >= 0.42)	WOOD
C	1/4" MAX. SHIM SPACE	-
F	#8 X 2" PH WOOD SCREW (1-3/8" MIN. EMBEDMENT)	STEEL
1	FRAME JAMB*	PVC
2	SILL*	PVC
3	FRAME HEAD*	PVC
4	TOP RAIL UPPER SASH*	PVC
5	KEEPER RAIL UPPER SASH*	PVC
6	GLAZING BEAD*	PVC
7	LOCK RAIL LOWER SASH*	PVC
8	LOWER SASH STILE*	PVC
10	REINFORCEMENT (6005-T5) ALUM	ALUM
11	REINFORCEMENT (6005-T5) ALUM	ALUM
12	BOTTOM RAIL LOWER SASH*	PVC
14	REINFORCEMENT (6005-T5) ALUM	ALUM
15	REINFORCEMENT (6005-T5) ALUM	ALUM
16	WEATHERSTRIP ULTRA FAB .270 PILE - 270 -1875B	-
17	WEATHERSTRIP SILLBULB (AMESBURY 32690)	-
20	LOCK	PVC
21	KEEPER	PVC
26	#8 X 1" TEK SCREW	STEEL

* THE APPROVED WHITE RIGID PVC EXTERIOR EXTRUSIONS FOR WINDOWS ARE TO BE PRODUCED BY EXTRUDERS LICENSEES IN "AAMA CERTIFICATION PROGRAMS FOR RIGID PVC EXTRUSIONS".

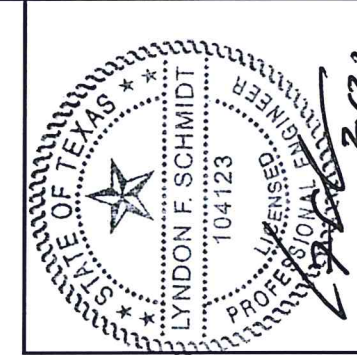
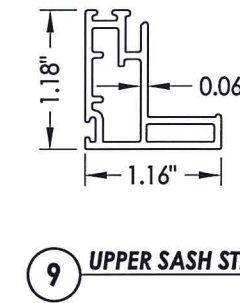
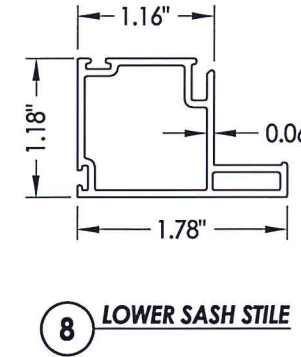
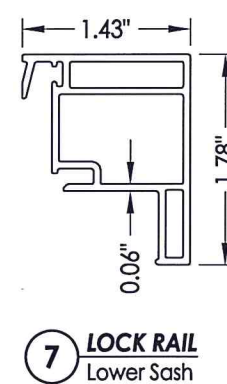
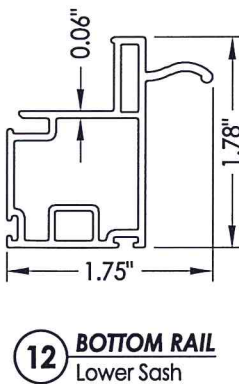
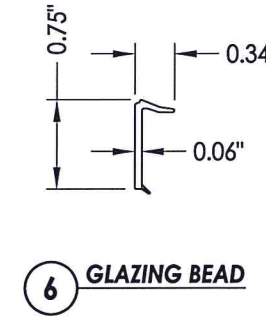
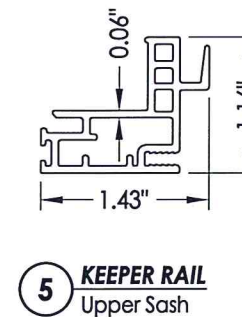
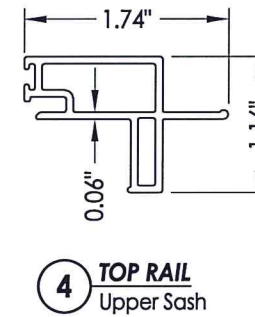
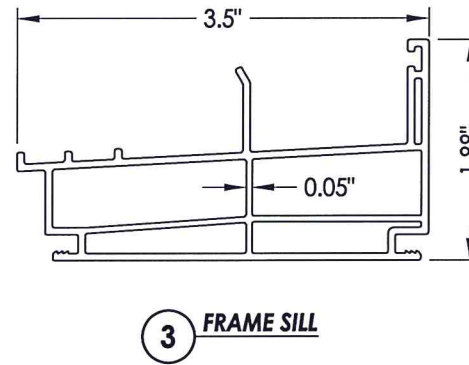
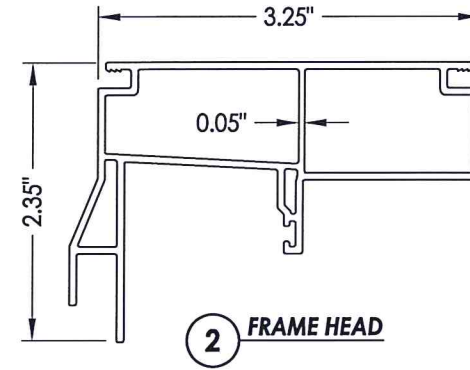
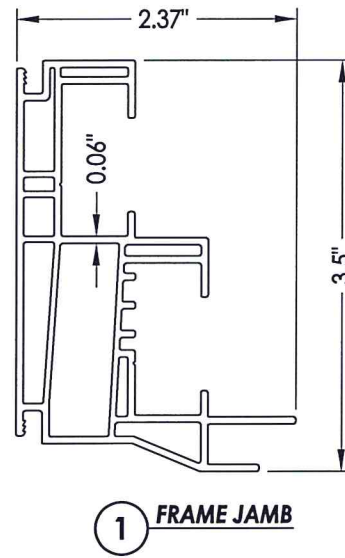
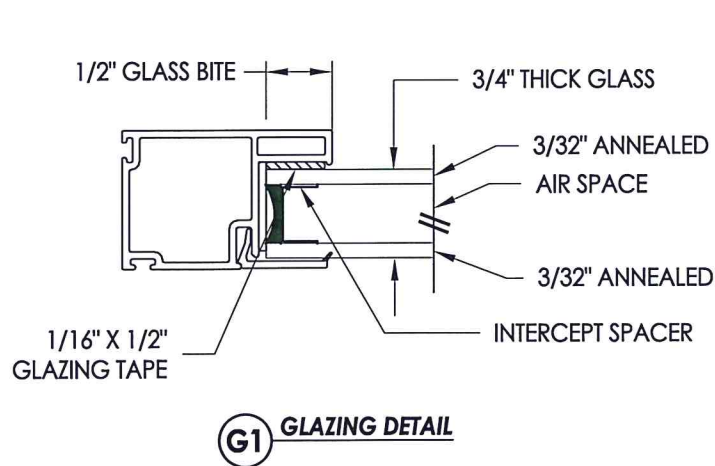

Documents Prepared By: Lyndon F. Schmidt, P.E.
TEXAS P.E. #104123

RW BUILDING CONSULTANTS, INC.
P.O. Box 230 Valrico FL, 33595
Phone No.: 813.659.9197

TEXAS BOARD OF PROFESSIONAL ENGINEERS
CERTIFICATE OF REGISTRATION # F-11852

PRODUCT:	5400/5400S SERIES Vinyl Double Hung Window
PART OR ASSEMBLY:	BILL OF MATERIALS COMPONENTS & GLAZING DETAILS
DATE:	9/09/14
SCALE:	N.T.S.
DWG. BY:	JK
CHK. BY:	LFS
DRAWING NO.:	TX-4472
SHEET	3 OF 3