

REVISIONS			
REV	DESCRIPTION	DATE	APPROVED

NOTES:

1. THE PRODUCT SHOWN HEREIN IS DESIGNED AND MANUFACTURED TO COMPLY WITH REQUIREMENTS OF THE INTERNATIONAL BUILDING CODE AND INTERNATIONAL RESIDENTIAL CODE WITH TEXAS STATE MODIFICATIONS.
2. WOOD FRAMING AND MASONRY OPENING TO BE DESIGNED AND ANCHORED TO PROPERLY TRANSFER ALL LOADS TO STRUCTURE. FRAMING AND MASONRY OPENING IS THE RESPONSIBILITY OF THE ARCHITECT OR ENGINEER OF RECORD.
3. 1X BUCK OVER MASONRY/CONCRETE IS OPTIONAL. WHERE 1X BUCK IS NOT USED DISSIMILAR MATERIALS MUST BE SEPARATED WITH APPROVED COATING OR MEMBRANE. SELECTION OF COATING OR MEMBRANE IS THE RESPONSIBILITY OF THE ARCHITECT OR ENGINEER OF RECORD.
4. ALLOWABLE STRESS INCREASE OF 1/3 WAS NOT USED IN THE DESIGN OF THE PRODUCT SHOWN HEREIN. WIND LOAD DURATION FACTOR Cd=1.6 WAS USED FOR WOOD ANCHOR CALCULATIONS.
5. FRAME MATERIAL: ALUMINUM 6063-T6.
6. UNITS MUST BE GLAZED PER ASTM E1300-04, SEE SHEET 3 FOR GLASS OPTIONS.
7. APPROVED IMPACT PROTECTIVE SYSTEM IS NOT REQUIRED FOR THIS PRODUCT IN WIND BORNE DEBRIS REGIONS.
8. SHIM AS REQUIRED AT EACH INSTALLATION ANCHOR WITH LOAD BEARING SHIM. SHIM WHERE SPACE OF 1/16" OR GREATER OCCURS. MAXIMUM ALLOWABLE SHIM STACK TO BE 1/4".
9. FOR ANCHORING INTO WOOD FRAMING OR 2X BUCK USE #14 WOOD SCREWS WITH SUFFICIENT LENGTH TO ACHIEVE A 1 7/16" MINIMUM EMBEDMENT INTO SUBSTRATE. LOCATE ANCHORS AS SHOWN IN ELEVATIONS AND FLUSH INSTALLATION DETAILS.
10. FOR ANCHORING INTO MASONRY/CONCRETE USE 1/4" TAPCONS WITH SUFFICIENT LENGTH TO ACHIEVE A 1 1/4" MINIMUM EMBEDMENT INTO SUBSTRATE WITH 2 1/2" MINIMUM EDGE DISTANCE. LOCATE ANCHORS AS SHOWN IN ELEVATIONS AND FLUSH INSTALLATION DETAILS.
11. FOR ANCHORING INTO METAL STRUCTURE USE #14 SMS OR SELF DRILLING SCREWS WITH SUFFICIENT LENGTH TO ACHIEVE 3 THREADS MINIMUM BEYOND STRUCTURE INTERIOR WALL. LOCATE ANCHORS AS SHOWN IN ELEVATIONS AND FLUSH INSTALLATION DETAILS.
12. ALL FASTENERS TO BE CORROSION RESISTANT.
13. INSTALLATION ANCHORS SHALL BE INSTALLED IN ACCORDANCE WITH ANCHOR MANUFACTURER'S INSTALLATION INSTRUCTIONS AND ANCHORS SHALL NOT BE USED IN SUBSTRATES WITH STRENGTHS LESS THAN THE MINIMUM STRENGTH SPECIFIED BELOW:
 - A. WOOD - MINIMUM SPECIFIC GRAVITY OF G=0.42
 - B. CONCRETE - MINIMUM COMPRESSIVE STRENGTH OF 3,192 PSI.
 - C. MASONRY - STRENGTH CONFORMANCE TO ASTM C-90, GRADE N, TYPE 1 (OR GREATER).
 - D. METAL STRUCTURE: STEEL 18GA, 33KSI OR ALUMINUM 6063-T5 1/8" THICK MINIMUM
14. SEALANT DETAILS TO BE DESIGNED IN ACCORDANCE WITH ASTM E 2112. SEALANT DETAILS DESIGN ARE THE RESPONSIBILITY OF THE GENERAL CONTRACTOR, OR THE ARCHITECT OR ENGINEER OF RECORD.

SIGNED: 03/06/2013

TABLE OF CONTENTS	
SHEET NO.	DESCRIPTION
1	NOTES
2	ELEVATIONS AND CHARTS
3	B.O.M & GLAZING DETAILS
4	CROSS SECTIONS
5 - 8	INSTALLATION DETAILS
9	COMPONENTS

		7500 AMSTERDAM DRIVE ORLANDO, FL 32832 Phone: 407.481.8400 Fax: 407.481.0505 www.windoorinc.com	
SERIES 9066 AWNING TWIN WINDOW LARGE MISSILE IMPACT NOTES			
DRAWN:		DWG NO.	
A.P.		08-01950	
SCALE NTS		DATE 03/05/13	
		SHEET 1 OF 9	



Luis R. Lomas P.E.
Texas No. 101889

REVISIONS			
REV	DESCRIPTION	DATE	APPROVED

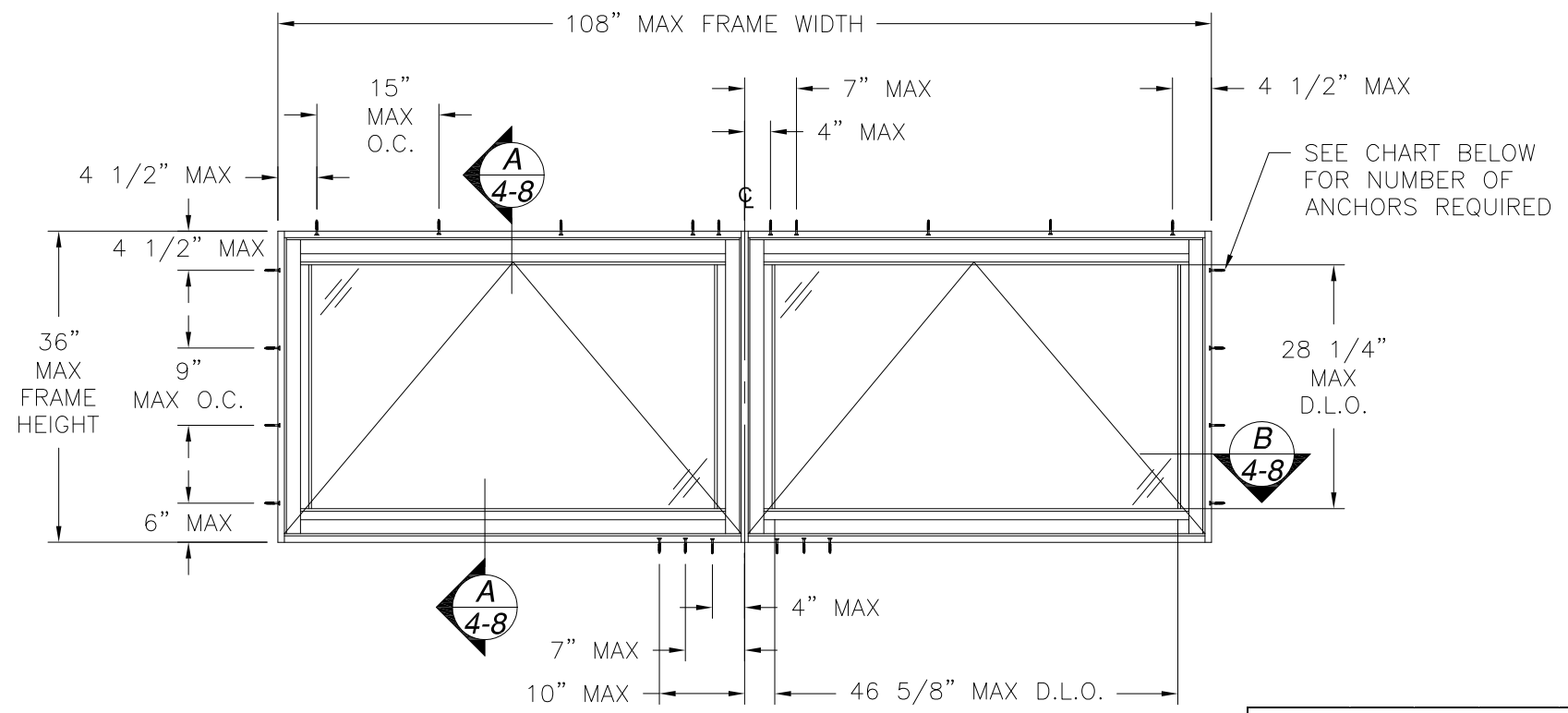

SERIES 9066 AWNING TWIN WINDOW
EXTERIOR VIEW

DESIGN PRESSURE RATING	IMPACT RATING
±90.0PSF	LARGE MISSILE IMPACT

MISSILE LEVEL D, WIND ZONE 4, AND HVHZ WITH GLAZING C AND D

DESIGN PRESSURE RATING	IMPACT RATING
+100.0/-120.0PSF	LARGE MISSILE IMPACT

MISSILE LEVEL D, WIND ZONE 4, AND HVHZ WITH GLAZING A AND B

Number of anchor locations required for twin units with 90psf rating																					
Frame Height (in)		Frame width (in)																			
		60.00				72.00				84.00				96.00				108.00			
Head	Jamb	Mull head cluster	Mull sill cluster	Head	Jamb	Mull head cluster	Mull sill cluster	Head	Jamb	Mull head cluster	Mull sill cluster	Head	Jamb	Mull head cluster	Mull sill cluster	Head	Jamb	Mull head cluster	Mull sill cluster		
18.00	2	2	1	2	3	1	1	2	3	1	1	2	3	2	1	2	3	2	1	2	
24.00	2	2	1	2	3	2	1	2	3	2	1	3	3	2	1	3	3	2	1	3	
30.00	2	2	1	2	3	2	1	3	3	2	1	3	3	2	1	3	3	3	1	4	
36.00	2	2	2	3	3	2	2	3	3	3	2	4	3	3	2	4	3	3	2	4	

Number of anchor locations required for twin units with 120psf rating																					
Frame Height (in)		Frame width (in)																			
		60.00				72.00				84.00				96.00				108.00			
Head	Jamb	Mull head cluster	Mull sill cluster	Head	Jamb	Mull head cluster	Mull sill cluster	Head	Jamb	Mull head cluster	Mull sill cluster	Head	Jamb	Mull head cluster	Mull sill cluster	Head	Jamb	Mull head cluster	Mull sill cluster		
18.00	2	2	1	2	3	2	1	2	3	2	1	3	3	2	1	3	3	2	1	3	
24.00	2	2	1	2	3	2	1	3	3	2	1	3	3	2	1	4	3	3	1	4	
30.00	2	2	2	3	3	3	2	3	3	3	2	4	3	3	2	4	4	3	2	5	
36.00	2	3	2	3	3	3	2	4	3	3	2	5	3	4	2	5	4	4	2	6	

SIGNED: 03/06/2013

WinDoor
INCORPORATED

7500 AMSTERDAM DRIVE
ORLANDO, FL 32832
Phone: 407.481.8400
Fax: 407.481.0505
www.windoorinc.com

SERIES 9066 AWNING TWIN WINDOW
LARGE MISSILE IMPACT
ELEVATION AND CHARTS

DRAWN: A.P. DWG NO. 08-01950 REV -

SCALE NTS DATE 03/05/13 SHEET 2 OF 9



Luis R. Lomas P.E.
Texas No. 101889

PARTS LIST				
NO.	PART NUMBER	DESCRIPTION	MANUFACTURER	MATERIAL
1	9060A02	FLUSH FRAME ASSEMBLY	KEYMARK	ALUMINUM 6063-T6
2	9060A04	FLANGE FRAME ASSEMBLY	KEYMARK	ALUMINUM 6063-T6
3	9060A01	SASH ASSEMBLY	KEYMARK	ALUMINUM 6063-T6
4	9060A03	COMMON POST	KEYMARK	ALUMINUM 6003-T6
5	S51989	HORIZONTAL SCREEN ADAPTER	KEYMARK	ALUMINUM 6003-T6
6	S51990	VERTICAL SCREEN ADAPTER	KEYMARK	ALUMINUM 6063-T6
7	115677.00.0520	OPERATOR TRACK & SLIDER ASSY	TRUTH	
8	851 112 8046	HINGE STORM B 16X	BRONZE CRAFT	
9	51.10.00.521	OPERATOR ENCORE S AWNING SS	TRUTH	
10	126.14XX	HDL/COVER (LH) S ENCORE TANGO	TRUTH	
11	21306	SPLINE CAP	TRUTH	
12	24.30.XX.004	LOCK ASSEMBLY	TRUTH	
13	23050.00.0500	LOCK SUPPORT PLATE	TRUTH	
14	9000LH-HD	KEEPER LEFT HAND - HD	SELJAN	SS 300 SERIES
15	9000RH-HD	KEEPER RIGHT HAND - HD	SELJAN	SS 300 SERIES
16	11914	TIE BAR	TRUTH	
17	12075P001	TIE BAR GUIDE	TRUTH	
18	900130	FRAME & SASH SNUBBER	ROTO	
19	S46329	GLASS STOP 7/16" - 9/16"	KEYMARK	ALUMINUM 6063-T6
20	S46084	GLASS STOP 1"	KEYMARK	ALUMINUM 6063-T6
21	TP1051	#6 GLAZING VINYL	TEAM PLASTICS	85 DUROMETER
22	FS07438	INTERIOR SASH CORNER KEY	KEYMARK	ALUMINUM 6003-T6
23	FS07440	SASH & FRAME CORNER	KEYMARK	ALUMINUM 6063-T6
24	FS07439	EXTERIOR SASH CORNER KEY	KEYMARK	ALUMINUM 6063-T6
25	FH07574	SCREEN FRAME	KEYMARK	ALUMINUM 6063-T6
26	FH05838	SCREEN FLANGE FRAME	KEYMARK	ALUMINUM 6063-T6
27	S10010-BL-2200R	SCREEN SPLINE	KEYMARK	
28	SBV-XX-0600Z	SCREEN CLOTH	KEYMARK	
29	QEZ 376	Q-LON FOAM FLAP SEAL	SCHLEGEL	
30	54076	CLOSED CELL EPDM SPONGE	LAUREN MFG.	EPDM SPONGE
31	54578	CLOSED CELL EPDM RUBBER	LAUREN MFG.	EPDM RUBBER
32	121998	.187"X.200" FIN SEAL	ULTRA FAB	
33		#8 X 3/8" PHILLIPS PH		
34		#8 X 5/8" PHILLIPS PH		
35		#8 X 1/2" PHILLIPS PH		
36		#8 X 1/2" PHILLIPS FH		
37		#8 X 1 1/4" PHILLIPS PH		
38		#10 X 1/2" PHILLIPS PH		
39		#10 X 1 1/4" FH		
40		#10 X 3" PH SELF-DRILLING		

REVISIONS			
REV	DESCRIPTION	DATE	APPROVED

PARTS LIST				
NO.	PART NUMBER	DESCRIPTION	MANUFACTURER	MATERIAL
41	01-100-7755-002	NEOPRENE GLASS SHIMS	FRANK LOWE	DUROMETER 80
42	SIKAFLEX 552	POLYURETHANE	SIKA	SEALANT

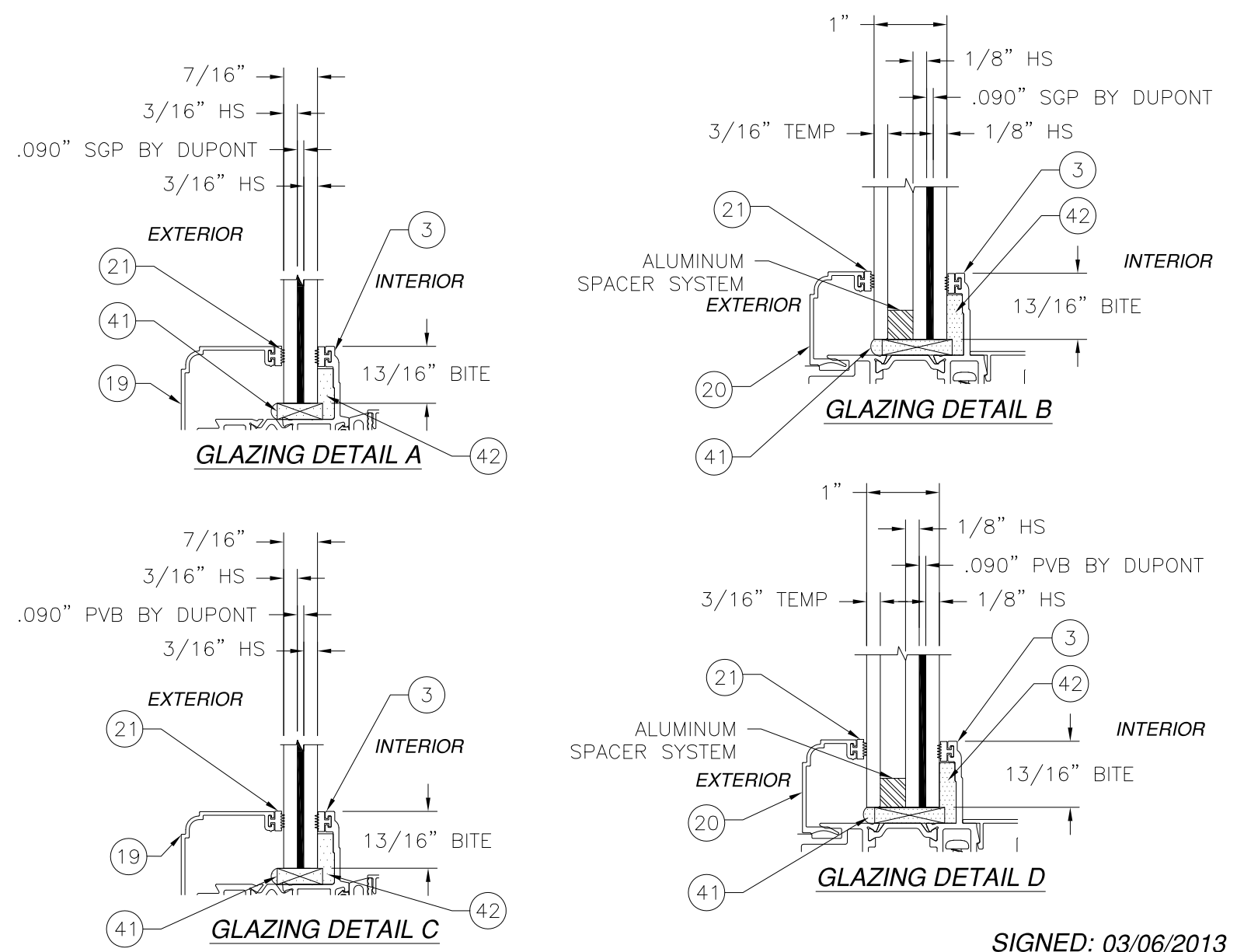

SIGNED: 03/06/2013

WinDoor
INCORPORATED

7500 AMSTERDAM DRIVE
ORLANDO, FL 32832
Phone: 407.481.8400
Fax: 407.481.0505
www.winwindowinc.com

SERIES 9066 AWNING TWIN WINDOW
LARGE MISSILE IMPACT
B.O.M. AND GLAZING DETAILS

DRAWN: A.P.	DWG NO. 08-01950	REV -
SCALE NTS	DATE 03/05/13	SHEET 3 OF 9

Luis R. Lomas P.E.
Texas No. 101889

REVISIONS			
REV	DESCRIPTION	DATE	APPROVED

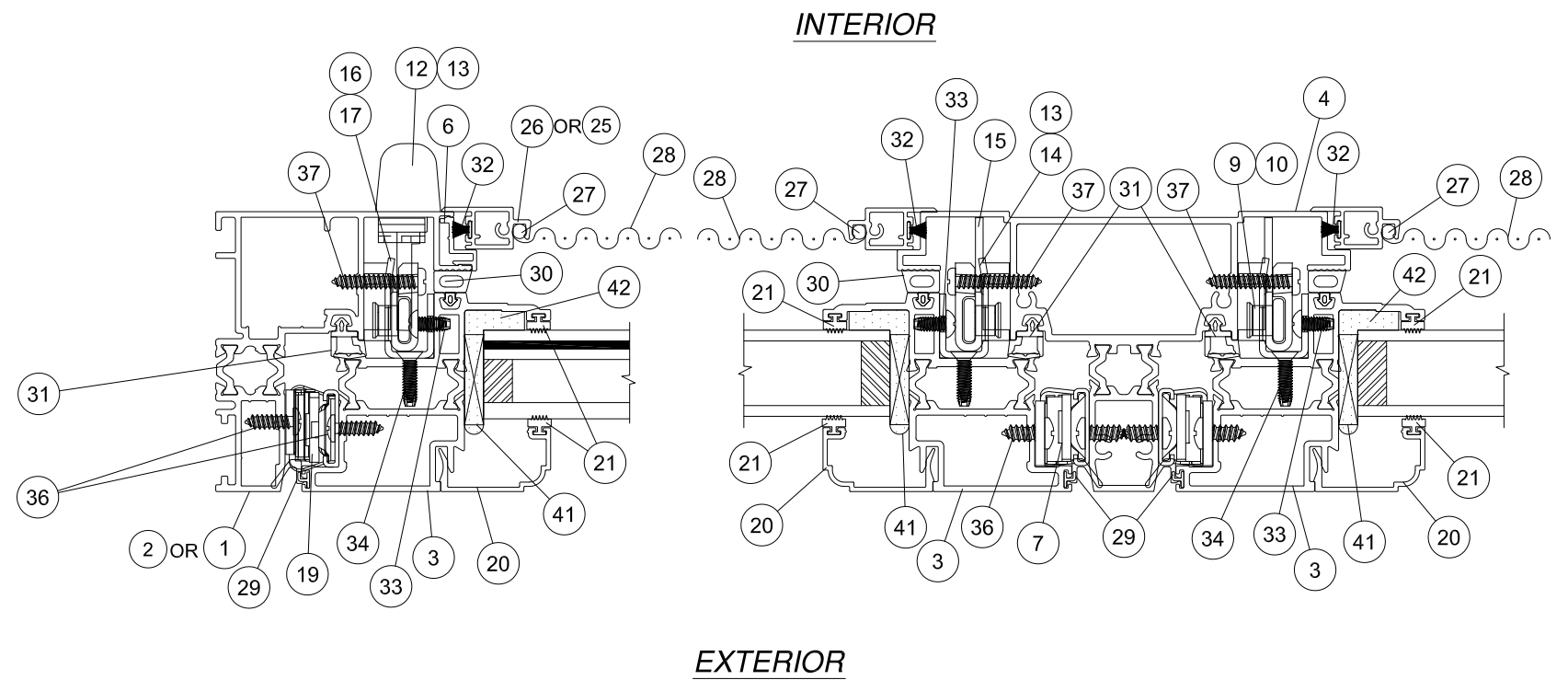
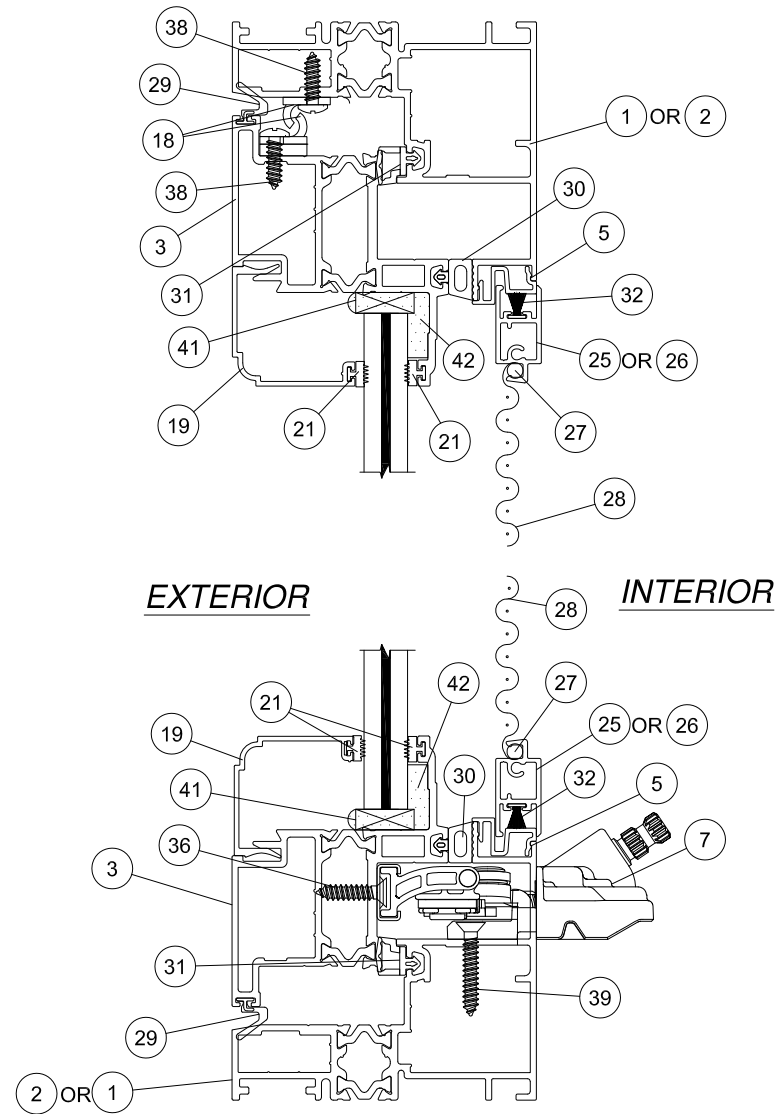

SIGNED: 03/06/2013

WinDoor INCORPORATED		7500 AMSTERDAM DRIVE ORLANDO, FL 32832 Phone: 407.481.8400 Fax: 407.481.0505 www.windoorinc.com
SERIES 9066 AWNING TWIN WINDOW LARGE MISSILE IMPACT CROSS SECTIONS		
DRAWN: A.P.	DWG NO. 08-01950	REV -
SCALE NTS	DATE 03/05/13	SHEET 4 OF 9

Luis R. Lomas P.E.
Texas No. 101889

REVISIONS			
REV	DESCRIPTION	DATE	APPROVED

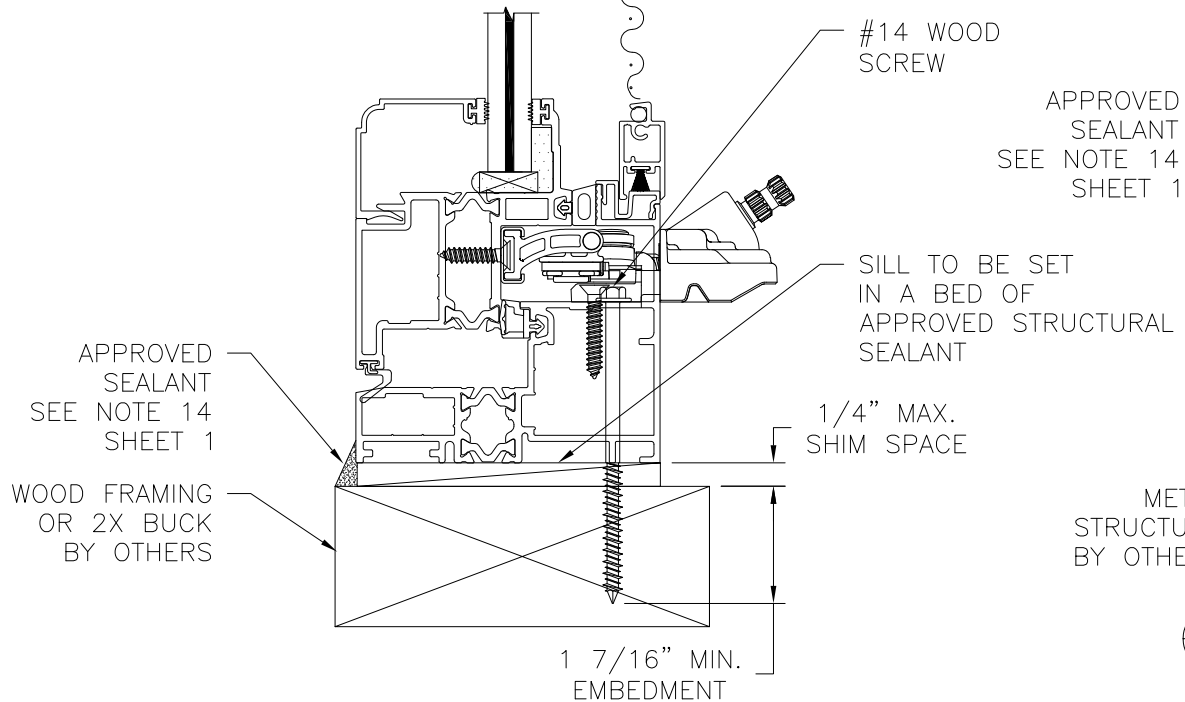
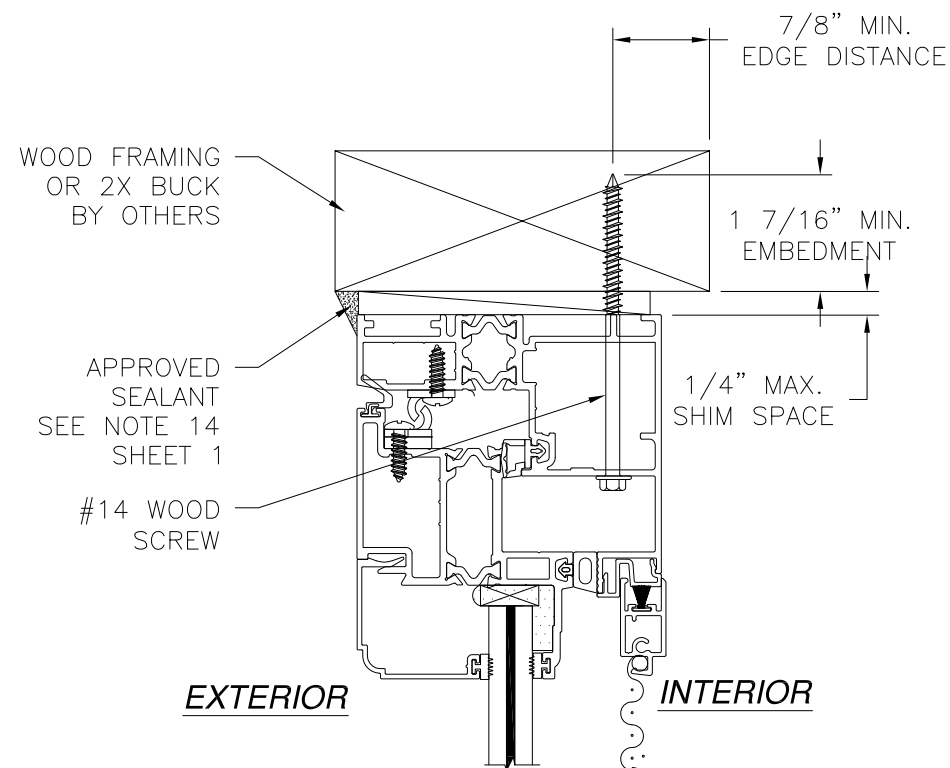

A/5 VERTICAL CROSS SECTION
WOOD FRAMING OR 2X BUCK INSTALLATION

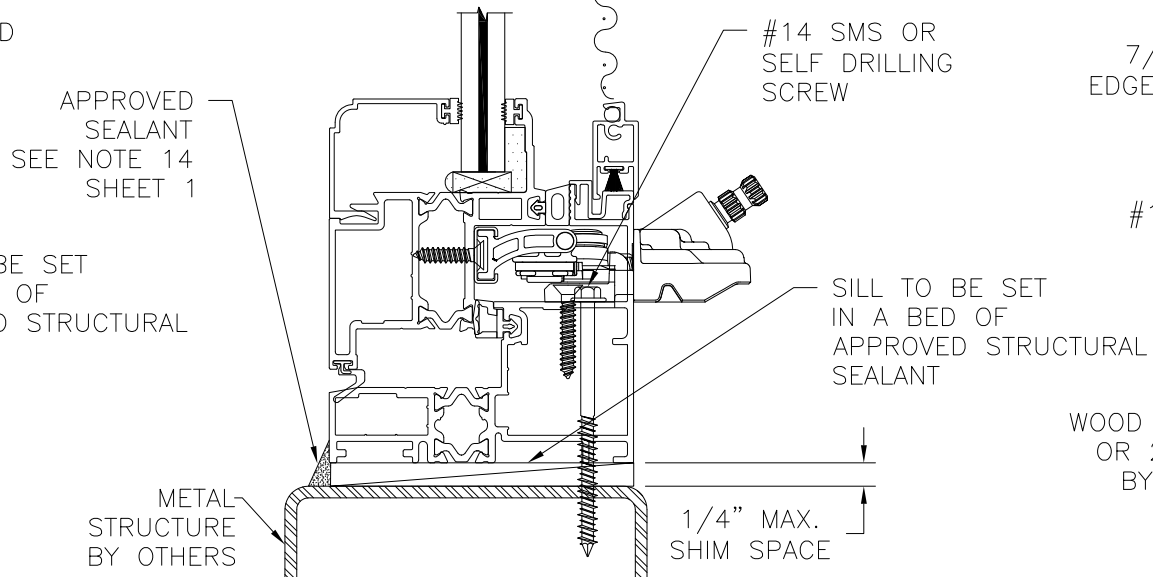
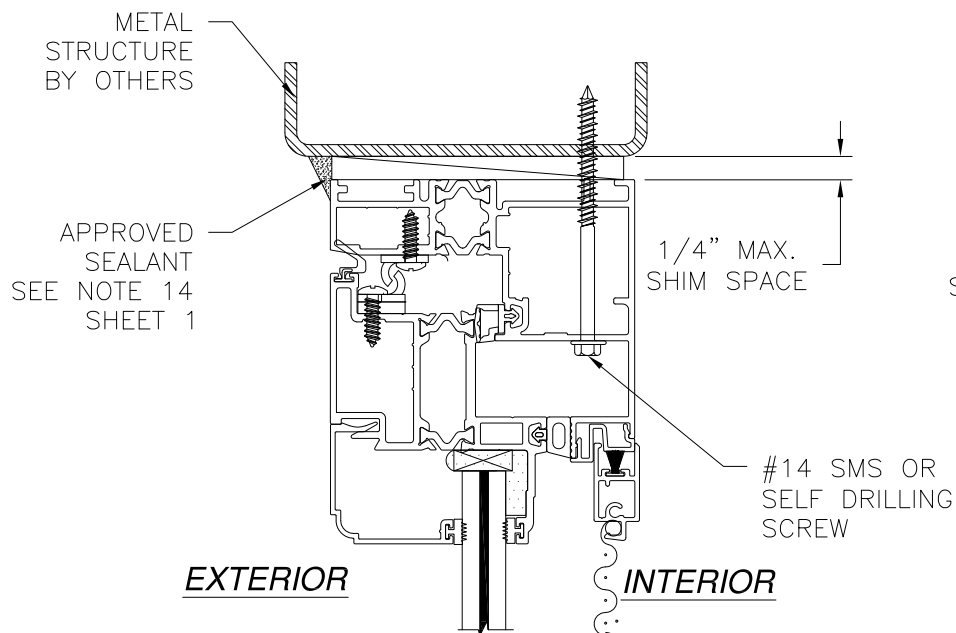

A/5 VERTICAL CROSS SECTION
METAL STRUCTURE INSTALLATION

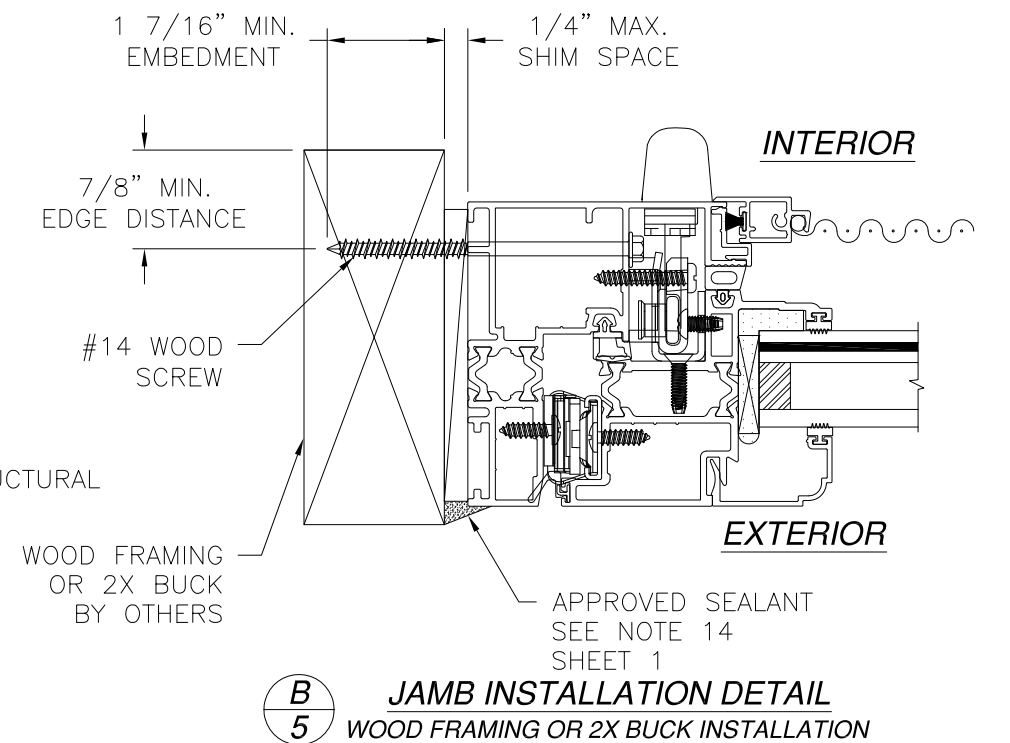
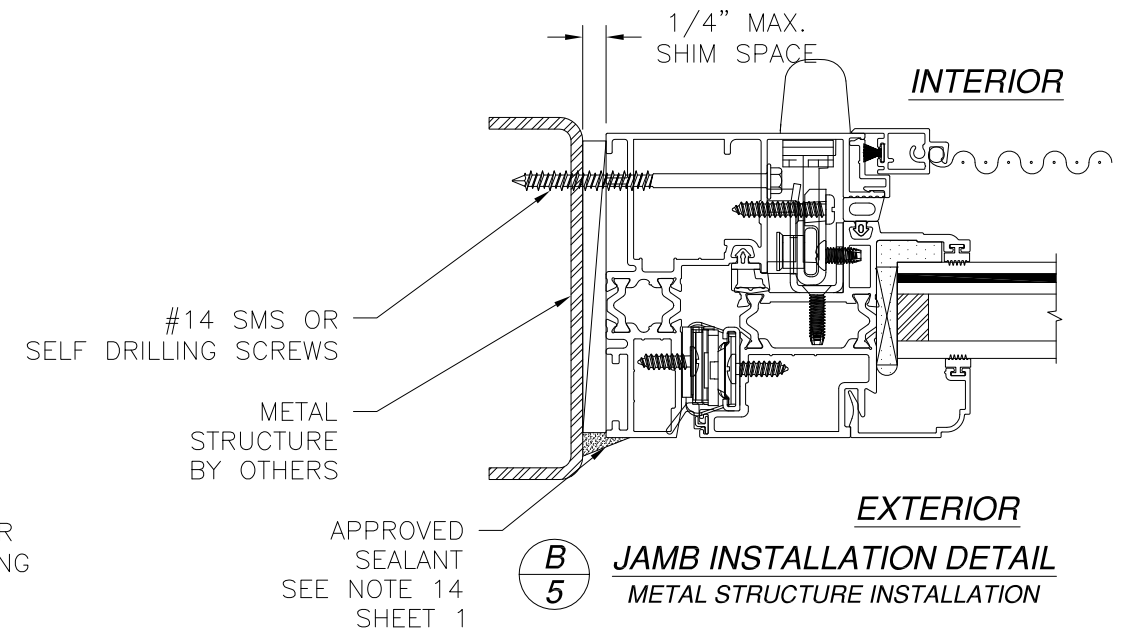

B/5 JAMB INSTALLATION DETAIL
WOOD FRAMING OR 2X BUCK INSTALLATION

NOTE:
INTERIOR AND EXTERIOR FINISHES, BY OTHERS, NOT SHOWN FOR CLARITY.

SIGNED: 03/06/2013

WinDoor INCORPORATED	7500 AMSTERDAM DRIVE ORLANDO, FL 32832	Phone: 407.481.8400 Fax: 407.481.0505 www.windoorinc.com
	SERIES 9066 AWNING TWIN WINDOW LARGE MISSILE IMPACT INSTALLATION DETAILS	
DRAWN: A.P.	DWG NO. 08-01950	REV -
SCALE NTS	DATE 03/05/13	SHEET 5 OF 9

Luis R. Lomas P.E.
Texas No. 101889

REVISIONS			
REV	DESCRIPTION	DATE	APPROVED

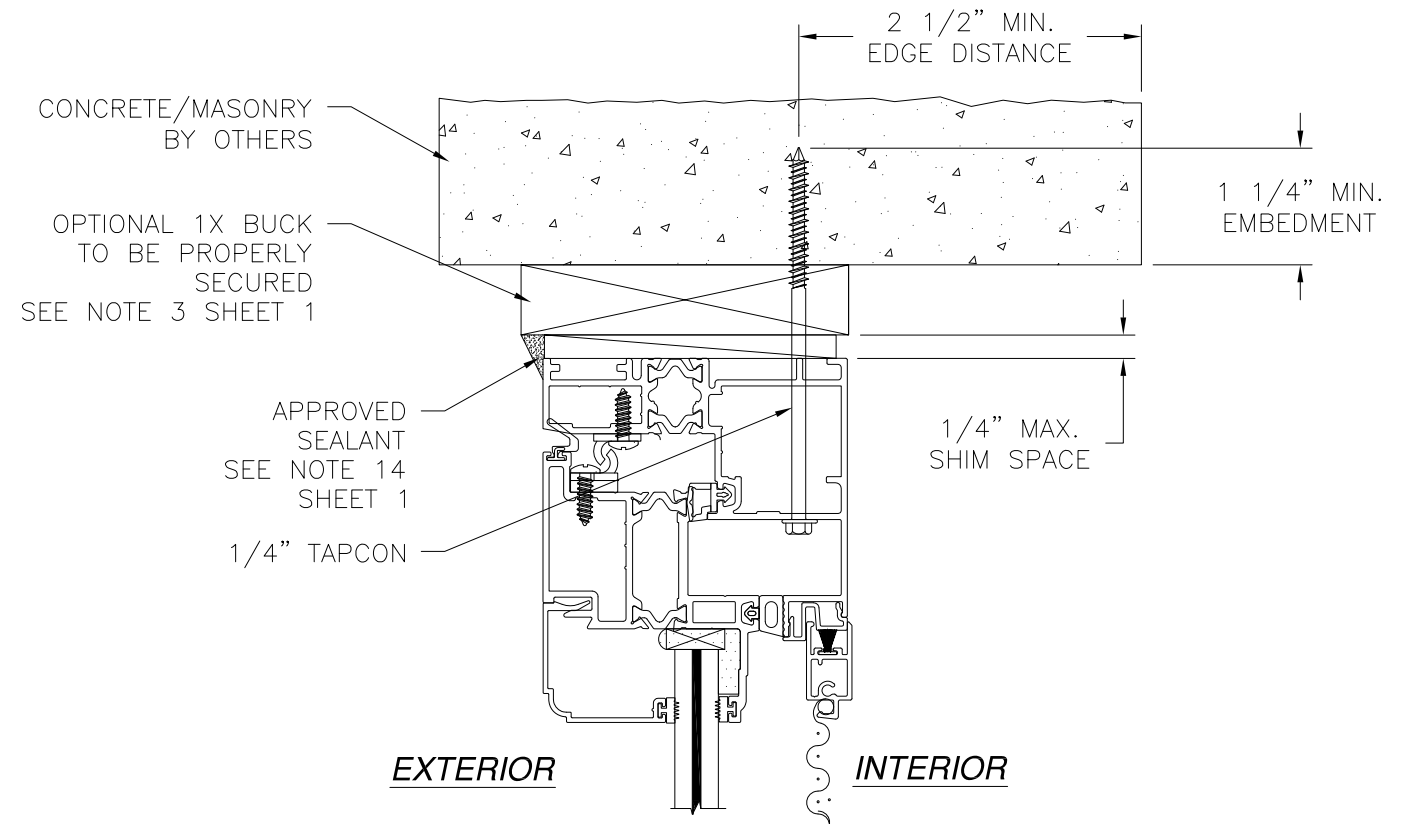

A
6 VERTICAL CROSS SECTION
CONCRETE/MASONRY INSTALLATION

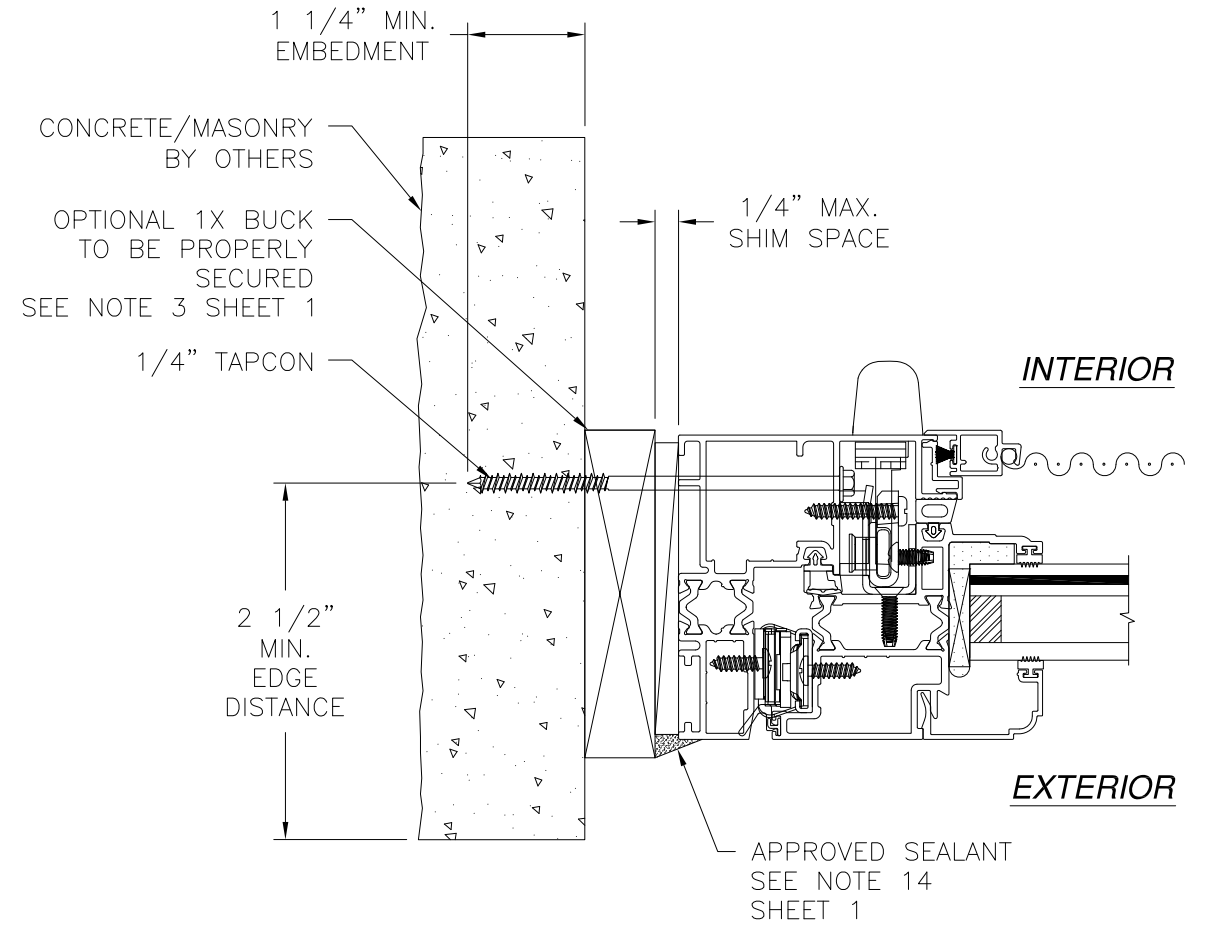

B
6 JAMB INSTALLATION DETAIL
CONCRETE/MASONRY INSTALLATION

NOTE:
INTERIOR AND EXTERIOR FINISHES, BY OTHERS, NOT SHOWN FOR CLARITY.

SIGNED: 03/06/2013

WinDoor INCORPORATED		7500 AMSTERDAM DRIVE ORLANDO, FL 32832 Phone: 407.481.8400 Fax: 407.481.0505 www.windoorinc.com
SERIES 9066 AWNING TWIN WINDOW LARGE MISSILE IMPACT INSTALLATION DETAILS		
DRAWN: A.P.	DWG NO. 08-01950	REV -
SCALE NTS	DATE 03/05/13	SHEET 6 OF 9



Luis R. Lomas P.E.
Texas No. 101889

REVISIONS			
REV	DESCRIPTION	DATE	APPROVED

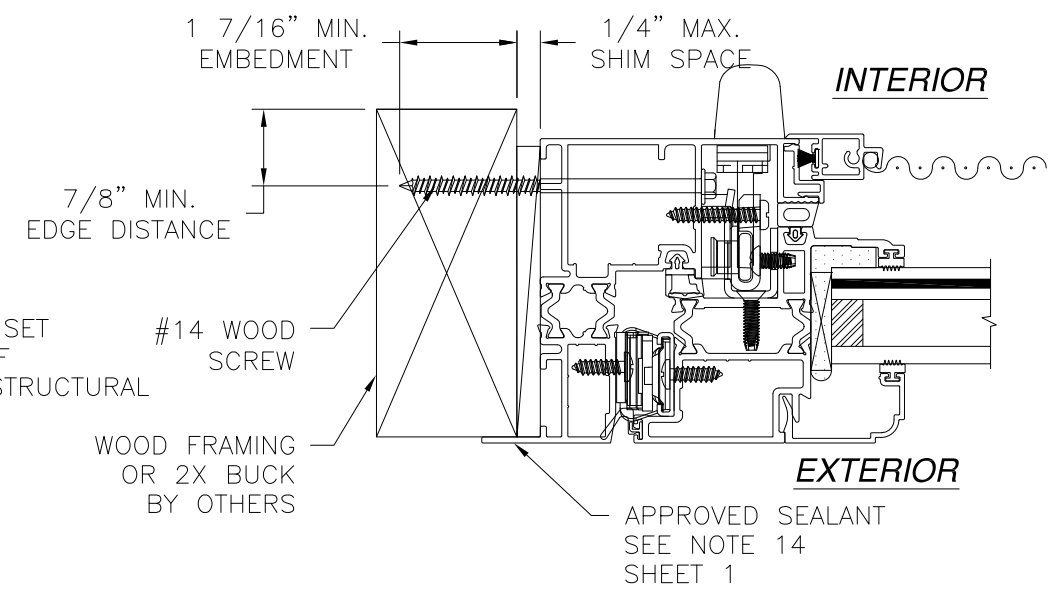
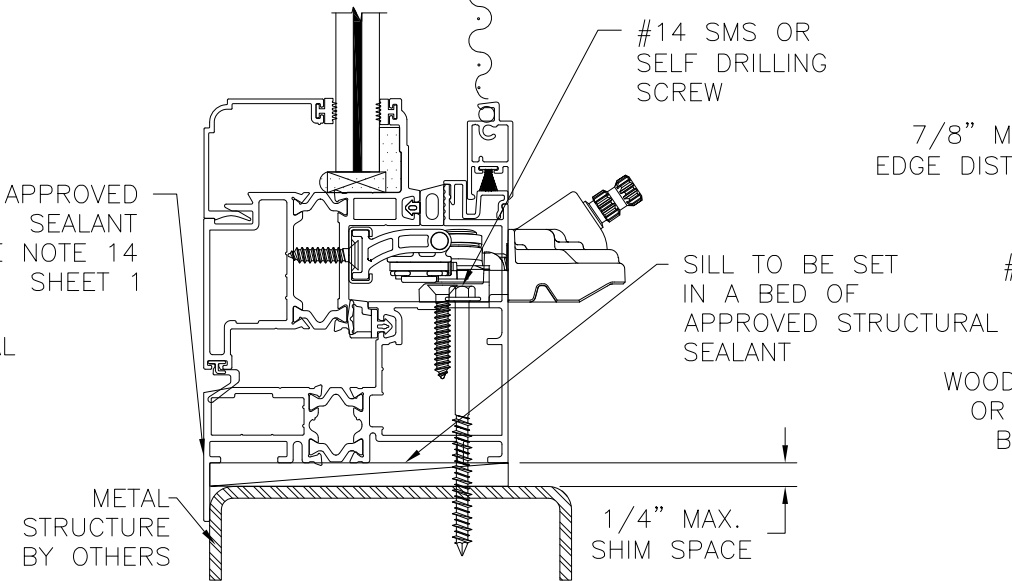
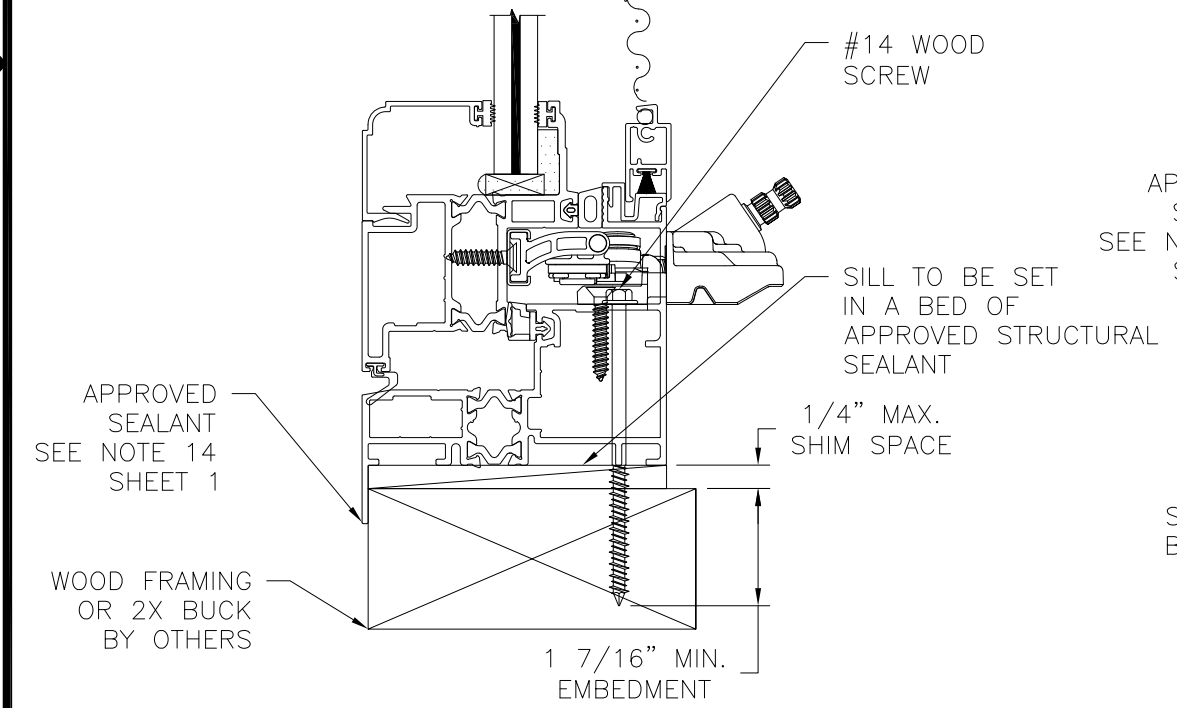
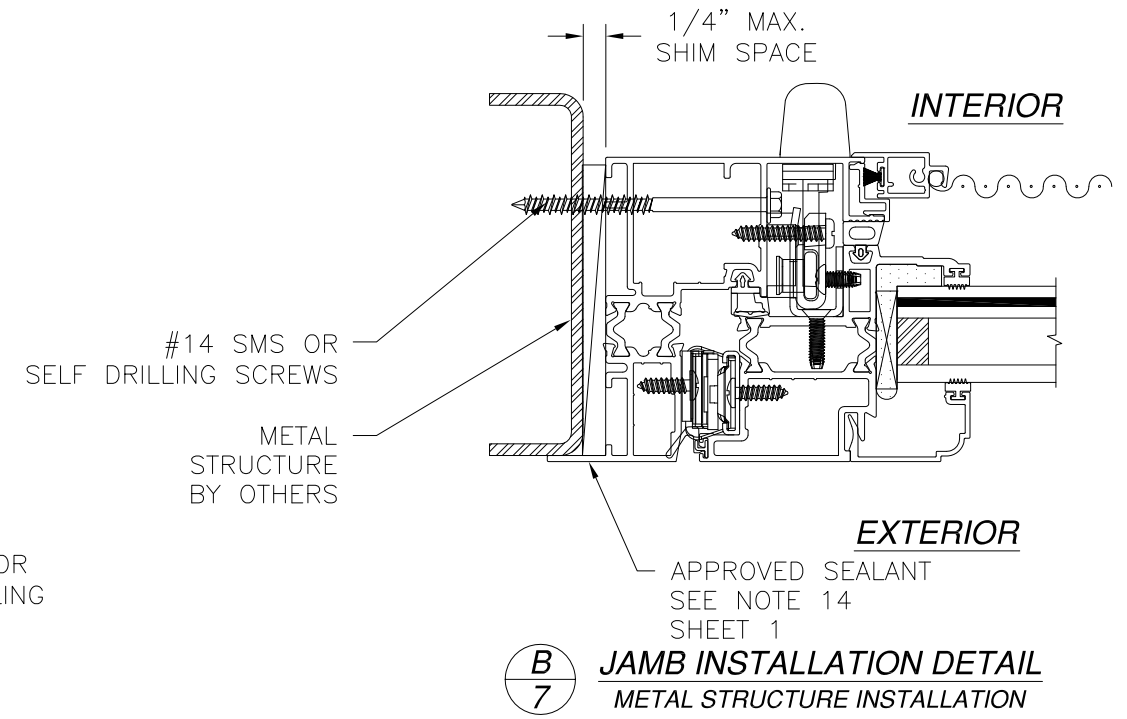
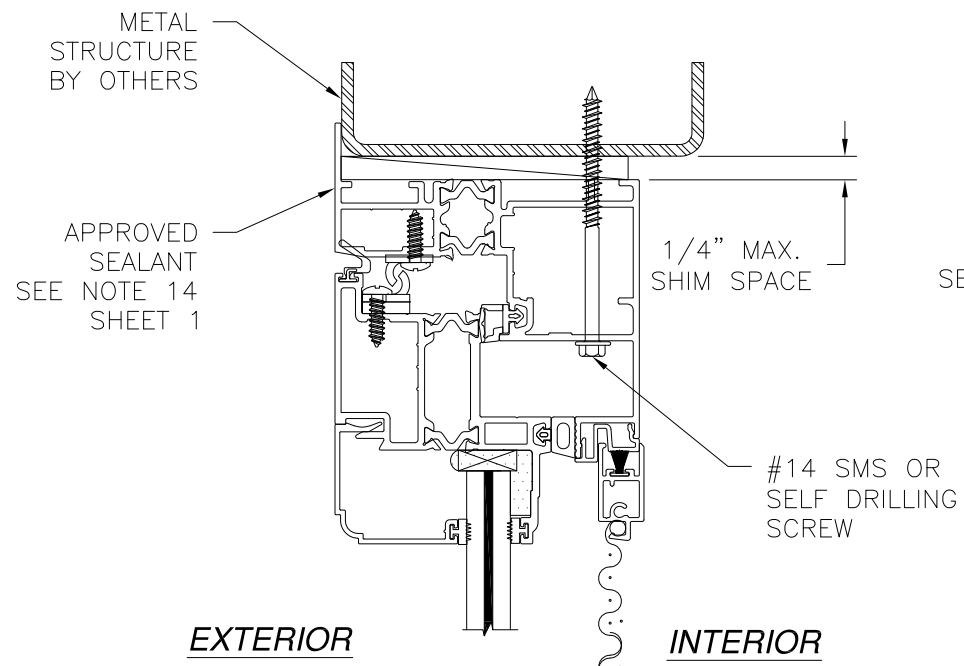
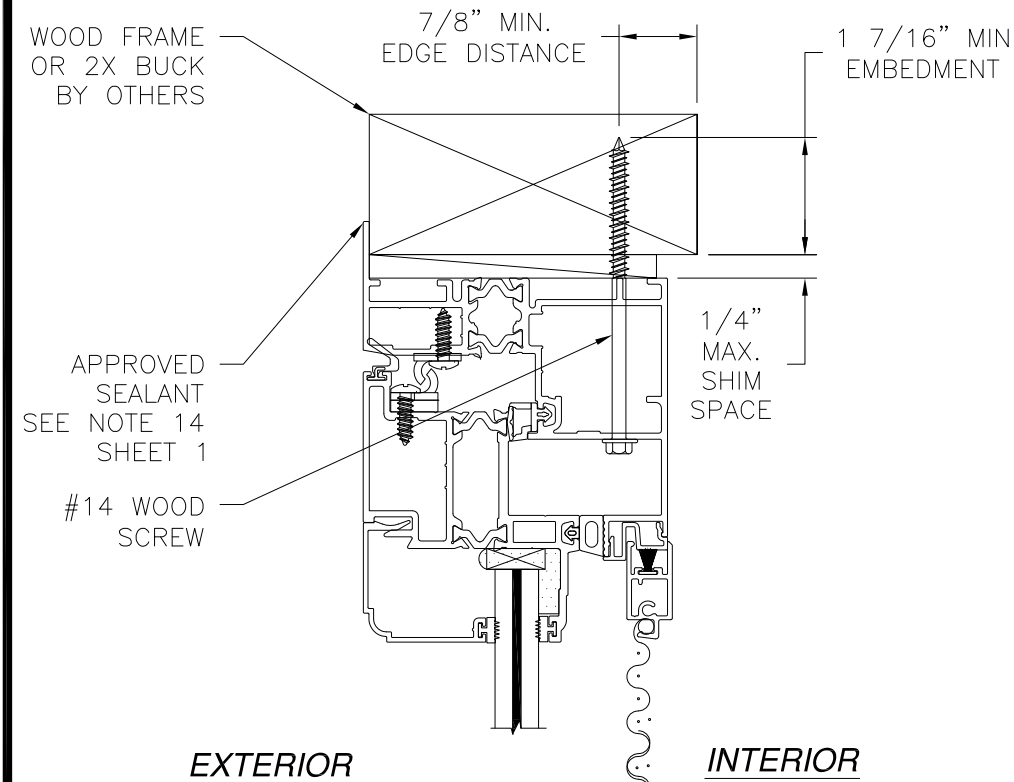

A/7 VERTICAL CROSS SECTION
WOOD FRAMING OR 2X BUCK INSTALLATION

A/7 VERTICAL CROSS SECTION
METAL STRUCTURE INSTALLATION

B/7 JAMB INSTALLATION DETAIL
WOOD FRAMING OR 2X BUCK INSTALLATION

B/7 JAMB INSTALLATION DETAIL
METAL STRUCTURE INSTALLATION

NOTE:
INTERIOR AND EXTERIOR FINISHES, BY OTHERS, NOT SHOWN FOR CLARITY.

SIGNED: 03/06/2013

WinDoor INCORPORATED		7500 AMSTERDAM DRIVE ORLANDO, FL 32832 Phone: 407.481.8400 Fax: 407.481.0505 www.windoorinc.com	
SERIES 9066 AWNING TWIN WINDOW LARGE MISSILE IMPACT INSTALLATION DETAILS			
DRAWN: A.P.	DWG NO. 08-01950	REV -	
SCALE NTS	DATE 03/05/13	SHEET 7 OF 9	

Luis R. Lomas P.E.
Texas No. 101889

REVISIONS			
REV	DESCRIPTION	DATE	APPROVED

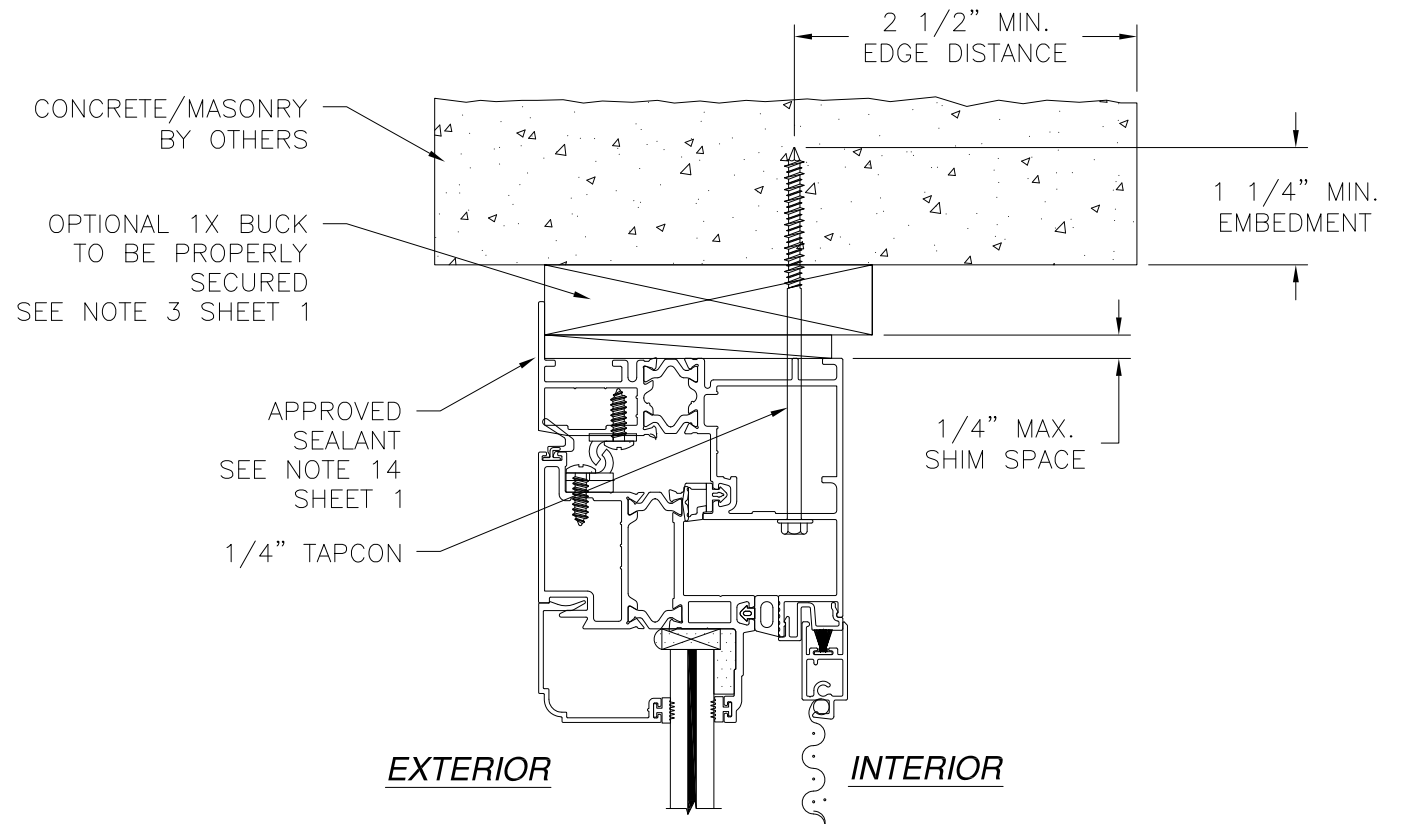

A
8 VERTICAL CROSS SECTION
CONCRETE/MASONRY INSTALLATION

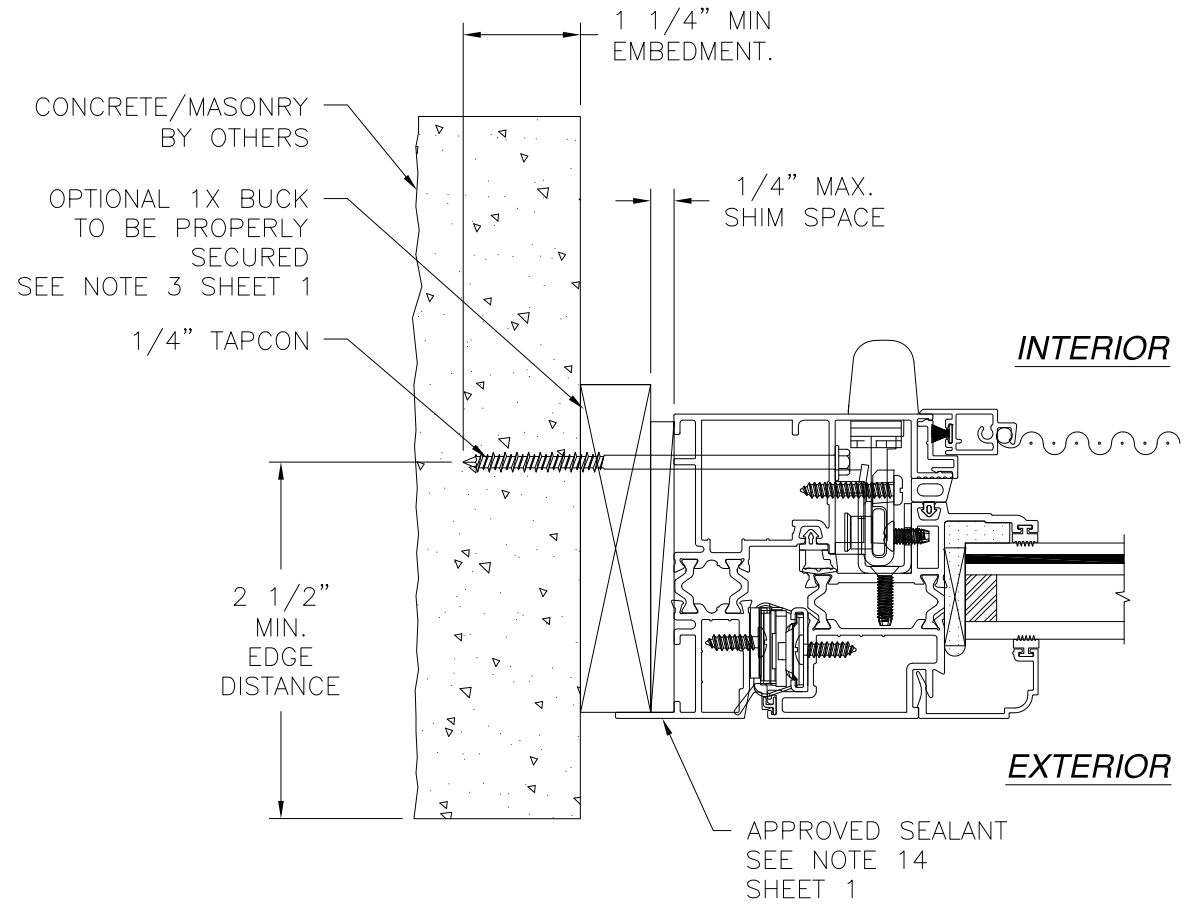

B
8 JAMB INSTALLATION DETAIL
CONCRETE/MASONRY INSTALLATION

NOTE:
INTERIOR AND EXTERIOR FINISHES, BY OTHERS, NOT SHOWN FOR CLARITY.

SIGNED: 03/06/2013

WinDoor INCORPORATED		7500 AMSTERDAM DRIVE ORLANDO, FL 32832 Phone: 407.481.8400 Fax: 407.481.0505 www.windoorinc.com
SERIES 9066 AWNING TWIN WINDOW LARGE MISSILE IMPACT INSTALLATION DETAILS		
DRAWN: A.P.	DWG NO. 08-01950	REV -
SCALE NTS	DATE 03/05/13	SHEET 8 OF 9



Luis R. Lomas P.E.
Texas No. 101889

REVISIONS			
REV	DESCRIPTION	DATE	APPROVED

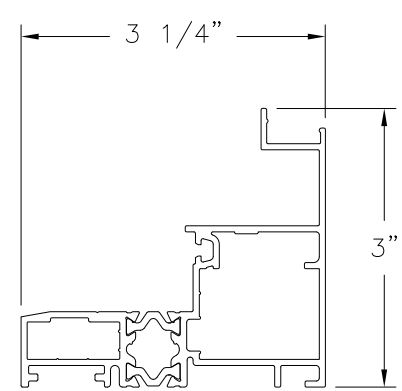

① **FRAME**
ALUMINUM 6063-T6 .065" THICK

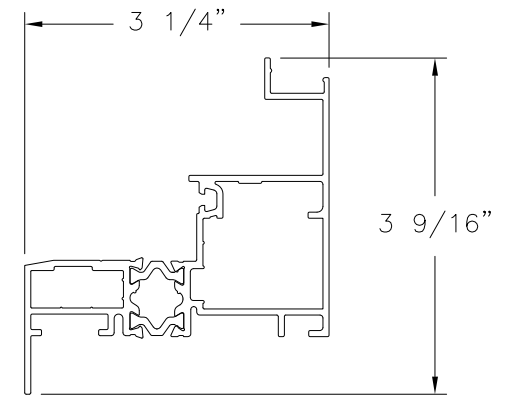

② **FLANGE FRAME**
ALUMINUM 6063-T6 .065" THICK

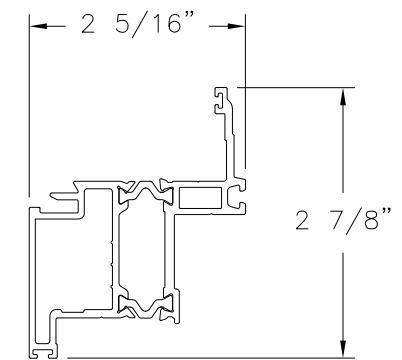

③ **SASH ASSEMBLY**
ALUMINUM 6063-T6 .070" THICK

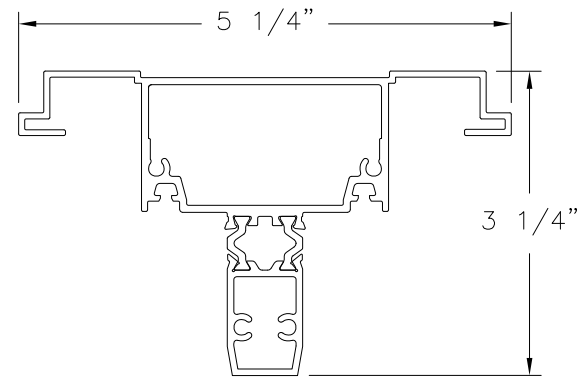

④ **COMMON POST**
ALUMINUM 6063-T6 .075" THICK

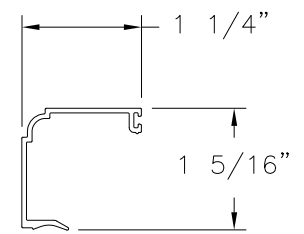

①⑨ **GLASS STOP**
ALUMINUM 6063-T6 .050" THICK

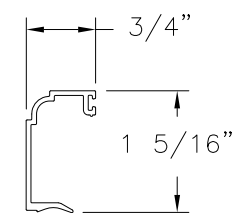

②⑩ **GLASS STOP**
ALUMINUM 6063-T6 .050" THICK

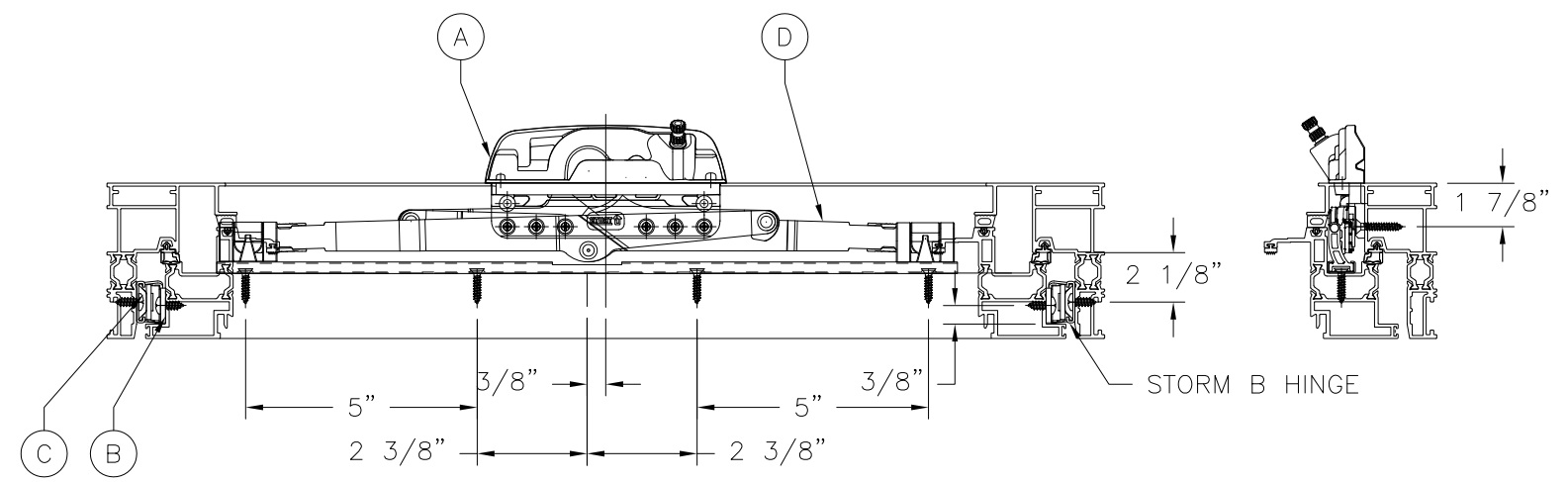

HARDWARE DETAIL

HARDWARE SCHEDULE	
A	(1) 51.10.00.521 OPER, ENCORE S AWN SS
B	(1) 12614.XX HDL/CVR, (LH) S ENCORE TANGO
C	(2) 851 112 8046 STORM B HINGE, 4BAR, BY BRONZE CRAFT
D	(1) 11577.00.0520 OPERATOR TRACK & SLIDER ASSY

SIGNED: 03/06/2013

WinDoor INCORPORATED	7500 AMSTERDAM DRIVE ORLANDO, FL 32832 Phone: 407.481.8400 Fax: 407.481.0505 www.windoorinc.com	
	SERIES 9066 AWNING TWIN WINDOW LARGE MISSILE IMPACT COMPONENTS	
DRAWN: A.P.	DWG NO. 08-01950	REV -
SCALE NTS	DATE 03/05/13	SHEET 9 OF 9



Luis R. Lomas P.E.
Texas No. 101889