

REVISIONS			
REV	DESCRIPTION	DATE	APPROVED

NOTES:

1. THE PRODUCT SHOWN HEREIN IS DESIGNED AND MANUFACTURED TO COMPLY WITH REQUIREMENTS OF THE 2006 IBC AND THE 2006 IRC WITH STATE OF TEXAS MODIFICATIONS AND WITH THE 2009 IBC, 2009 IRC, 2012 IBC, 2012 IRC, 2015 IBC AND 2015 IRC.
2. WOOD FRAMING AND MASONRY OPENING TO BE DESIGNED AND ANCHORED TO PROPERLY TRANSFER ALL LOADS TO STRUCTURE. FRAMING AND MASONRY OPENING IS THE RESPONSIBILITY OF THE ARCHITECT OR ENGINEER OF RECORD.
3. 1X BUCK OVER MASONRY/CONCRETE IS OPTIONAL.
4. WHERE SHIM OR BUCK THICKNESS IS LESS THAN 1-1/2" UNITS MUST BE ANCHORED THROUGH THE FRAME IN ACCORDANCE WITH MANUFACTURER'S PUBLISHED INSTALLATION INSTRUCTIONS. ANCHORS SHALL BE SECURELY FASTENED DIRECTLY INTO MASONRY, CONCRETE OR OTHER STRUCTURAL SUBSTRATE MATERIAL.
5. WHERE WOOD BUCK THICKNESS IS 1-1/2" OR GREATER, BUCK SHALL BE SECURELY FASTENED TO MASONRY, CONCRETE OR OTHER STRUCTURAL SUBSTRATE. UNITS MAY BE ANCHORED THROUGH FRAME TO SECURED WOOD BUCK IN ACCORDANCE WITH MANUFACTURER'S PUBLISHED INSTALLATION INSTRUCTIONS.
6. WHERE 1X BUCK IS NOT USED DISSIMILAR MATERIALS MUST BE SEPARATED WITH APPROVED COATING OR MEMBRANE. SELECTION OF COATING OR MEMBRANE IS THE RESPONSIBILITY OF THE ARCHITECT OR ENGINEER OF RECORD.
7. BUCKS SHALL EXTEND BEYOND UNIT FRAME INTERIOR FACE SO THAT FULL FRAME SUPPORT IS PROVIDED.
8. FOR FIN INSTALLATION SHIM AS NEEDED. FOR FRAME INSTALLATION SHIM AS REQUIRED AT EACH ANCHOR LOCATION WITH LOAD BEARING SHIM. SHIM WHERE SPACE OF 1/16" OR GREATER OCCURS. MAXIMUM ALLOWABLE SHIM STACK TO BE 1/4".
9. SHIMS SHALL BE LOCATED, APPLIED AND MADE FROM MATERIALS AND THICKNESS CAPABLE OF SUSTAINING APPLICABLE LOADS.
10. WIND LOAD DURATION FACTOR Cd=1.6 WAS USED FOR WOOD ANCHOR CALCULATIONS.
11. FRAME MATERIAL: EXTRUDED RIGID PVC.
12. UNITS MUST BE GLAZED PER ASTM E1300-04/09, SEE GLAZING DETAILS IN SHEET 2.
13. APPROVED IMPACT PROTECTIVE SYSTEM IS NOT REQUIRED FOR THIS PRODUCT IN WIND BORNE DEBRIS REGIONS.
14. FOR ANCHORING THROUGH FIN INTO WOOD FRAMING OR 2X BUCK USE #8 WOOD SCREWS WITH SUFFICIENT LENGTH TO ACHIEVE A 1 1/4" MINIMUM EMBEDMENT INTO SUBSTRATE. LOCATE ANCHORS AS SHOWN IN ELEVATIONS AND INSTALLATION DETAILS.
15. FOR ANCHORING THROUGH FRAME INTO WOOD FRAMING OR 2X BUCK USE #8 WOOD SCREWS WITH SUFFICIENT LENGTH TO ACHIEVE A 1 1/4" MINIMUM EMBEDMENT INTO SUBSTRATE. LOCATE ANCHORS AS SHOWN IN ELEVATIONS AND INSTALLATION DETAILS.
16. FOR ANCHORING THROUGH FRAME INTO MASONRY/CONCRETE USE 3/16" TAPCONS WITH SUFFICIENT LENGTH TO ACHIEVE A 1 1/4" MINIMUM EMBEDMENT INTO SUBSTRATE WITH 2" MINIMUM EDGE DISTANCE. LOCATE ANCHORS AS SHOWN IN ELEVATIONS AND INSTALLATION DETAILS.
17. FOR ANCHORING THROUGH FRAME INTO METAL STRUCTURE USE #8 SMS OR SELF DRILLING SCREWS WITH SUFFICIENT LENGTH TO ACHIEVE 3 THREADS MINIMUM BEYOND STRUCTURE INTERIOR WALL. LOCATE ANCHORS AS SHOWN IN ELEVATIONS AND INSTALLATION DETAILS.
18. ALL FASTENERS TO BE CORROSION RESISTANT.
19. INSTALLATION ANCHORS SHALL BE INSTALLED IN ACCORDANCE WITH ANCHOR MANUFACTURER'S INSTALLATION INSTRUCTIONS AND ANCHORS SHALL NOT BE USED IN SUBSTRATES WITH STRENGTHS LESS THAN THE MINIMUM STRENGTH SPECIFIED BELOW:
 - A. WOOD: MINIMUM SPECIFIC GRAVITY OF G=0.42
 - B. CONCRETE: MINIMUM COMPRESSIVE STRENGTH OF 2,000 PSI.
 - C. MASONRY: HOLLOW/FILLED BLOCK PER ASTM C90 WITH Fm=2,000PSI MINIMUM.
 - D. METAL STRUCTURE: STEEL 18GA (.048") FY=33KSI/FU=52KSI OR ALUMINUM 6063-T5 FU=30KSI .048" THICK MINIMUM

TABLE OF CONTENTS	
SHEET NO.	DESCRIPTION
1	NOTES
2	ELEVATIONS
3 - 5	INSTALLATION DETAILS
6	COMPONENTS

WINDOW MART 5760 ALBERT PIKE ROYAL, AR 71968		
SERIES 6201 NC/6202 REP VINYL DOUBLE HUNG WINDOW - IMPACT NOTES		
DRAWN: A.R.	DWG NO. 08-03478	REV -
SCALE NTS	DATE 07/25/19	SHEET 1 OF 6
L. ROBERTO LOMAS P.E. 1432 WOODFORD RD LEWISVILLE, NC 27023 434-688-0609 rllomas@lrlomaspe.com		

SIGNED: 07/30/2019



Luis R. Lomas P.E.
TX No.: 101889

REVISIONS			
REV	DESCRIPTION	DATE	APPROVED

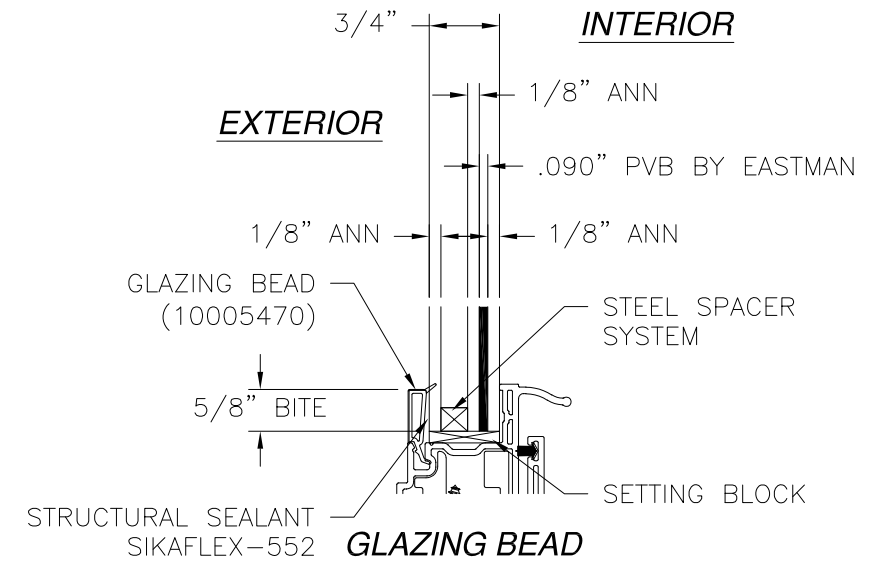
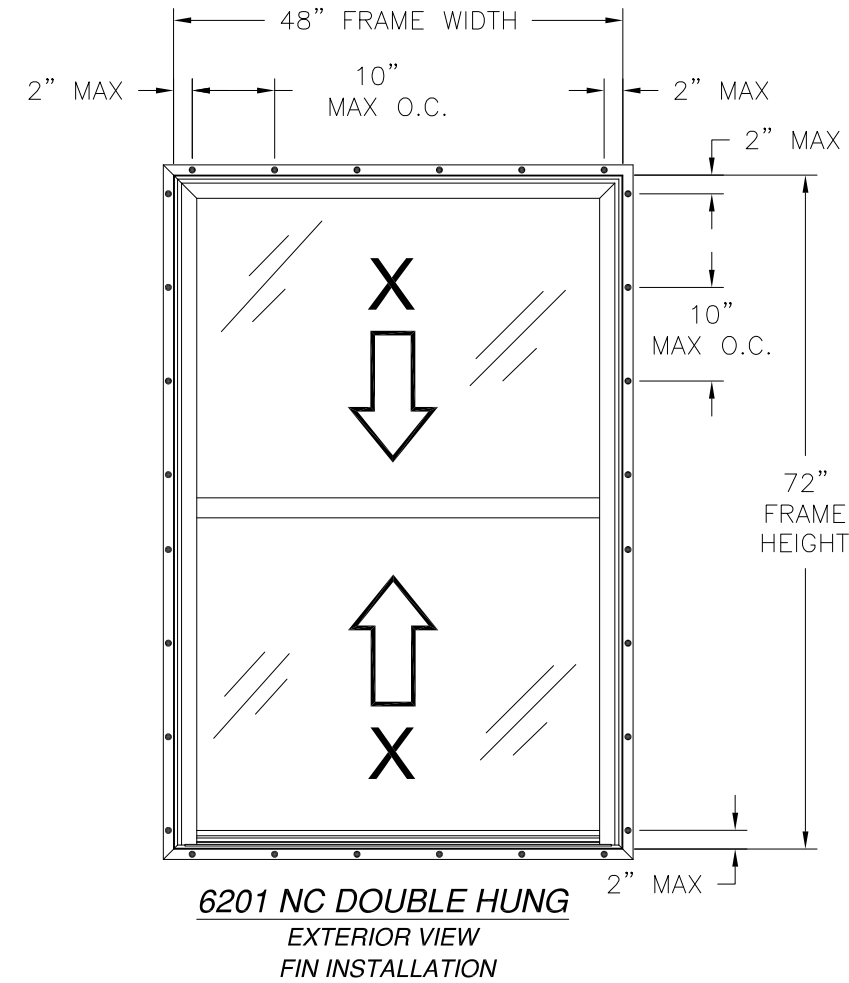
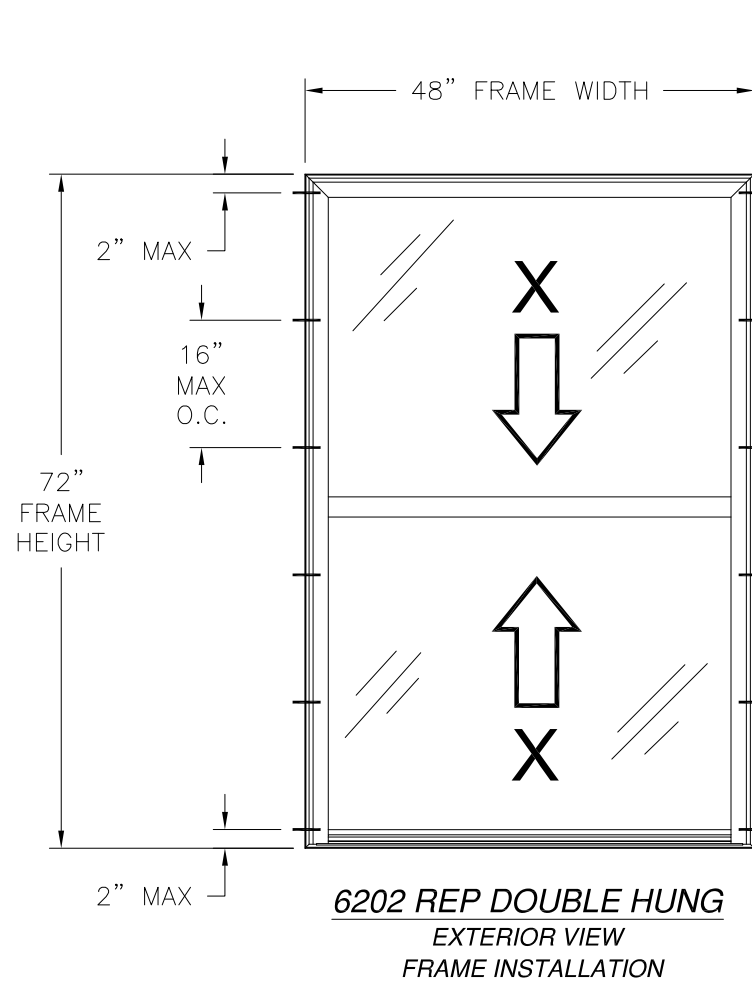

DESIGN PRESSURE RATING	IMPACT RATING
±50.0PSF	LARGE AND SMALL MISSILE IMPACT

MISSILE LEVEL D, WIND ZONE 4
48" X 72" UNIT SHOWN. OTHER SIZES APPROVED AS LONG AS
FRAME AREA DOES NOT EXCEED 24.0 FT²

- NOTES:
- TOP SASH SIZE: 34 5/8" X 43 3/8"
 - BOTTOM SASH SIZE: 35 5/8" X 44 3/8"
 - D.L.O. SIZE: 41 3/8" X 32 3/8"

HARDWARE SCHEDULE

A.	(2) BSI. 1/2 COIL SPRING BALANCE SYSTEM AT EACH JAMB
B.	(4) METALIC SPRING LOADED TILT LATCHES, AT 1 1/2" FROM EACH BOTTOM AND UPPER SASH TOP/BOTTOM RAIL CORNER
C.	(4) FS PIVOT BAR, TWO AT EACH END OF OPERABLE SASH BOTTOM RAIL
D.	(1) ALUMINUM IMPACT CLIP REINFORCEMENT, 1 1/2" FROM EACH SASH BOTTOM LOCK RAIL CORNER
E.	(2) CAST CAM LOCKS, AT 8" FROM EACH JAMB CORNER ON SASH TOP RAIL LOCKING INTO KEEPERS IN KEEPER RAIL
F.	ALUMINUM REINFORCEMENT (10300082) AT SASH STILES AND TOP RAILS
G.	ALUMINUM REINFORCEMENT (10300083) AT LOCK RAIL
H.	ALUMINUM "U" SHAPED REINFORCEMENT (10300096) AT SILL

SIGNED: 07/30/2019

WINDOW MART
5760 ALBERT PIKE
ROYAL, AR 71968

SERIES 6201 NC/6202 REP VINYL
DOUBLE HUNG WINDOW - IMPACT
ELEVATION

DRAWN: A.R.	DWG NO. 08-03478	REV -
SCALE NTS	DATE 07/25/19	SHEET 2 OF 6

L. ROBERTO LOMAS P.E.
1432 WOODFORD RD LEWISVILLE, NC 27023
434-688-0609 rllomas@rlomaspe.com



Luis R. Lomas P.E.
TX No.: 101889

REVISIONS			
REV	DESCRIPTION	DATE	APPROVED

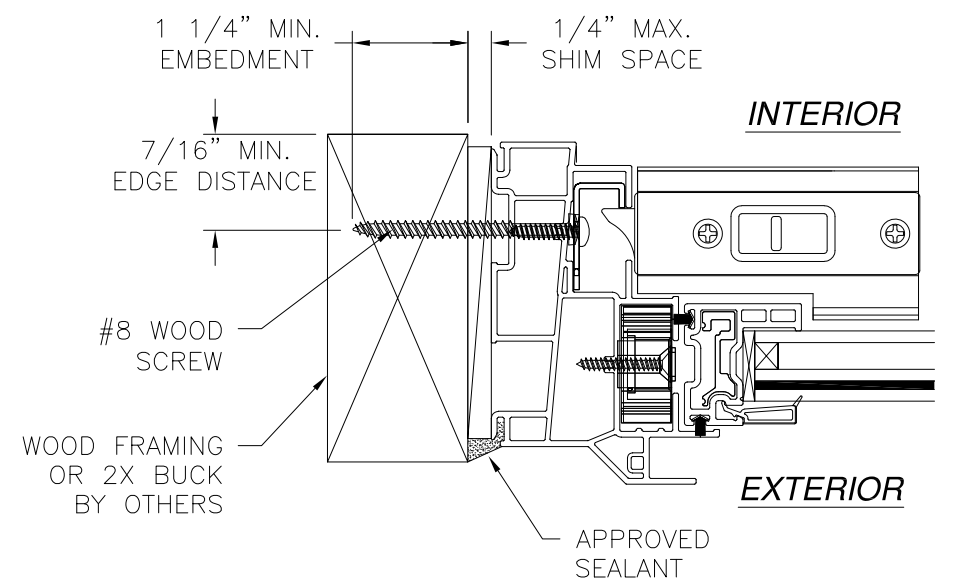
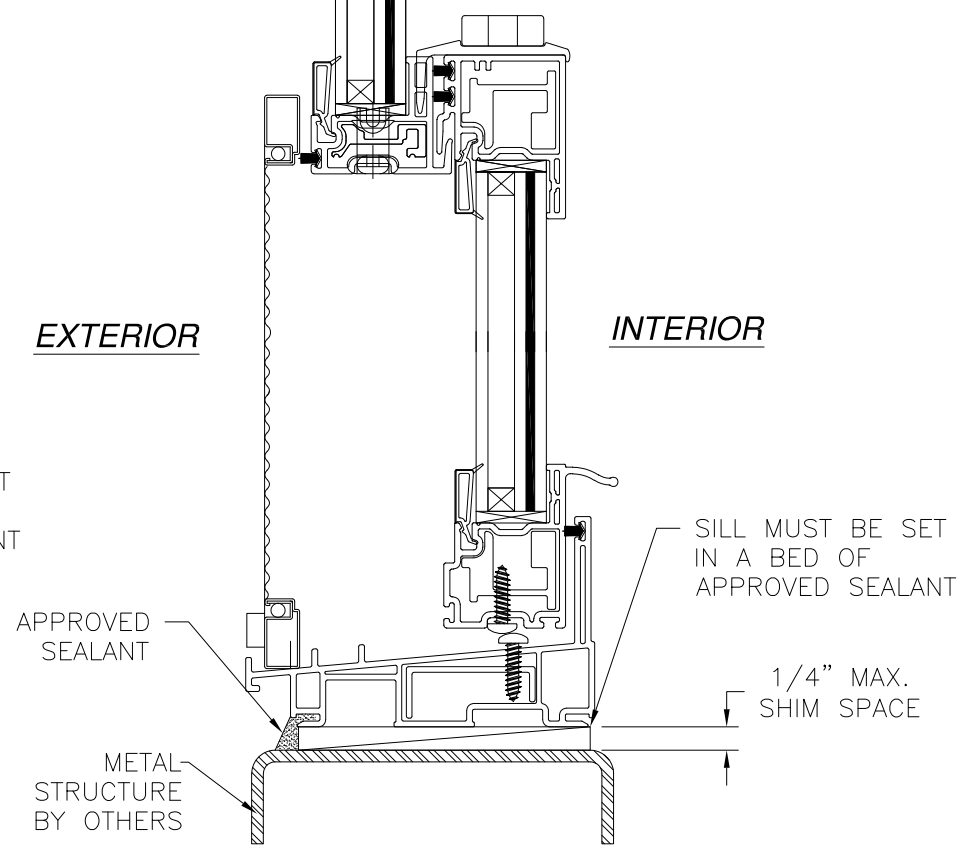
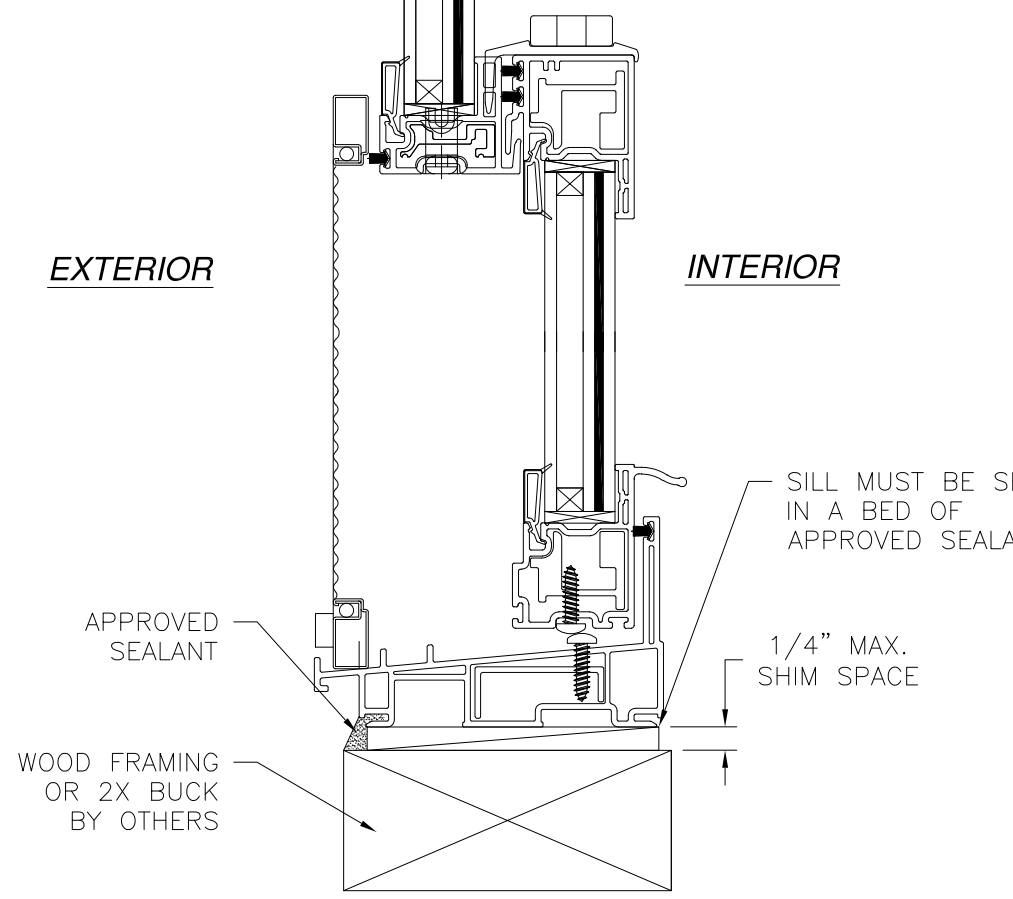
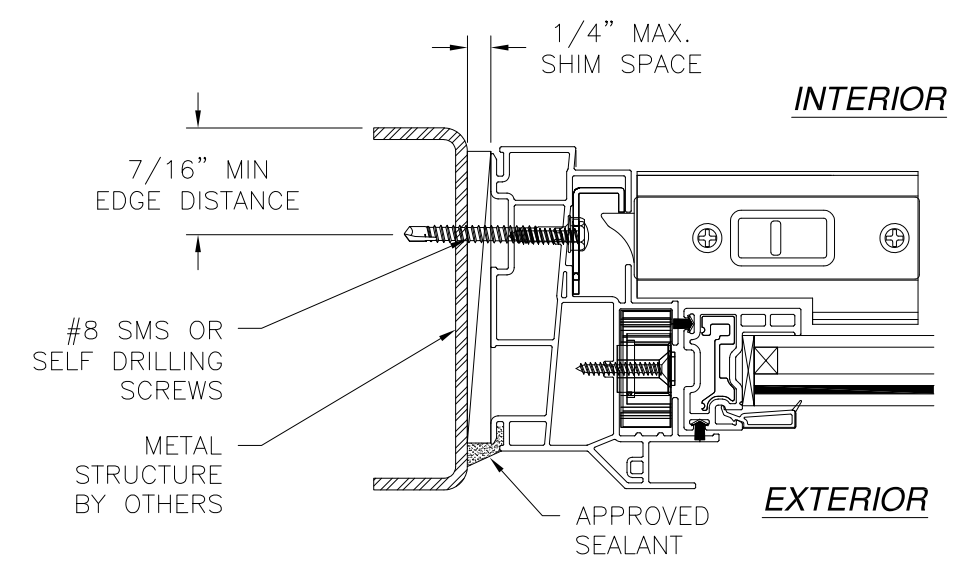
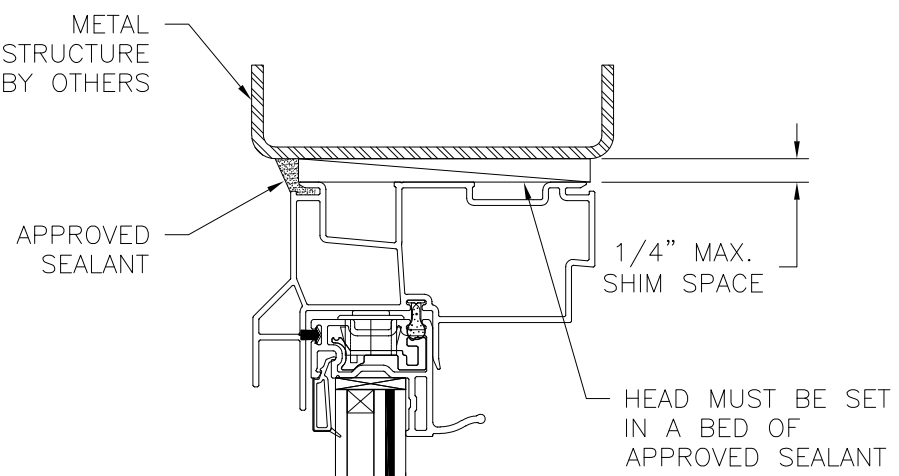
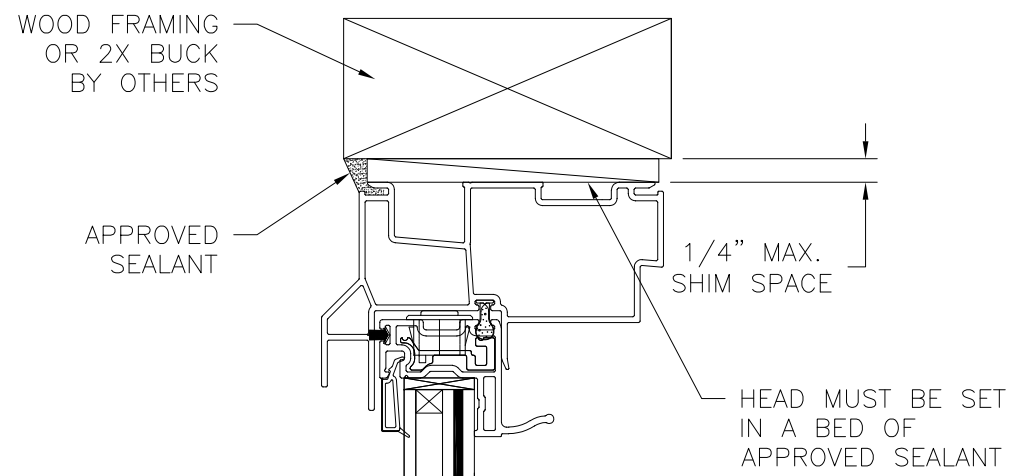

VERTICAL CROSS SECTION
WOOD FRAMING OR 2X BUCK INSTALLATION

VERTICAL CROSS SECTION
METAL STRUCTURE INSTALLATION

JAMB INSTALLATION DETAIL
METAL STRUCTURE INSTALLATION

JAMB INSTALLATION DETAIL
WOOD FRAMING OR 2X BUCK INSTALLATION

NOTES:
 1. INTERIOR AND EXTERIOR FINISHES, BY OTHERS, NOT SHOWN FOR CLARITY.
 2. PERIMETER AND JOINT SEALANT BY OTHERS TO BE DESIGNED IN ACCORDANCE WITH ASTM E2112

WINDOW MART 5760 ALBERT PIKE ROYAL, AR 71968		
SERIES 6201 NC/6202 REP VINYL DOUBLE HUNG WINDOW – IMPACT INSTALLATION DETAILS		
DRAWN: A.R.	DWG NO. 08-03478	REV -
SCALE NTS	DATE 07/25/19	SHEET 3 OF 6
L. ROBERTO LOMAS P.E. 1432 WOODFORD RD LEWISVILLE, NC 27023 434-688-0609 rllomas@rlomaspe.com		

SIGNED: 07/30/2019



Luis R. Lomas P.E.
TX No.: 101889

REVISIONS			
REV	DESCRIPTION	DATE	APPROVED

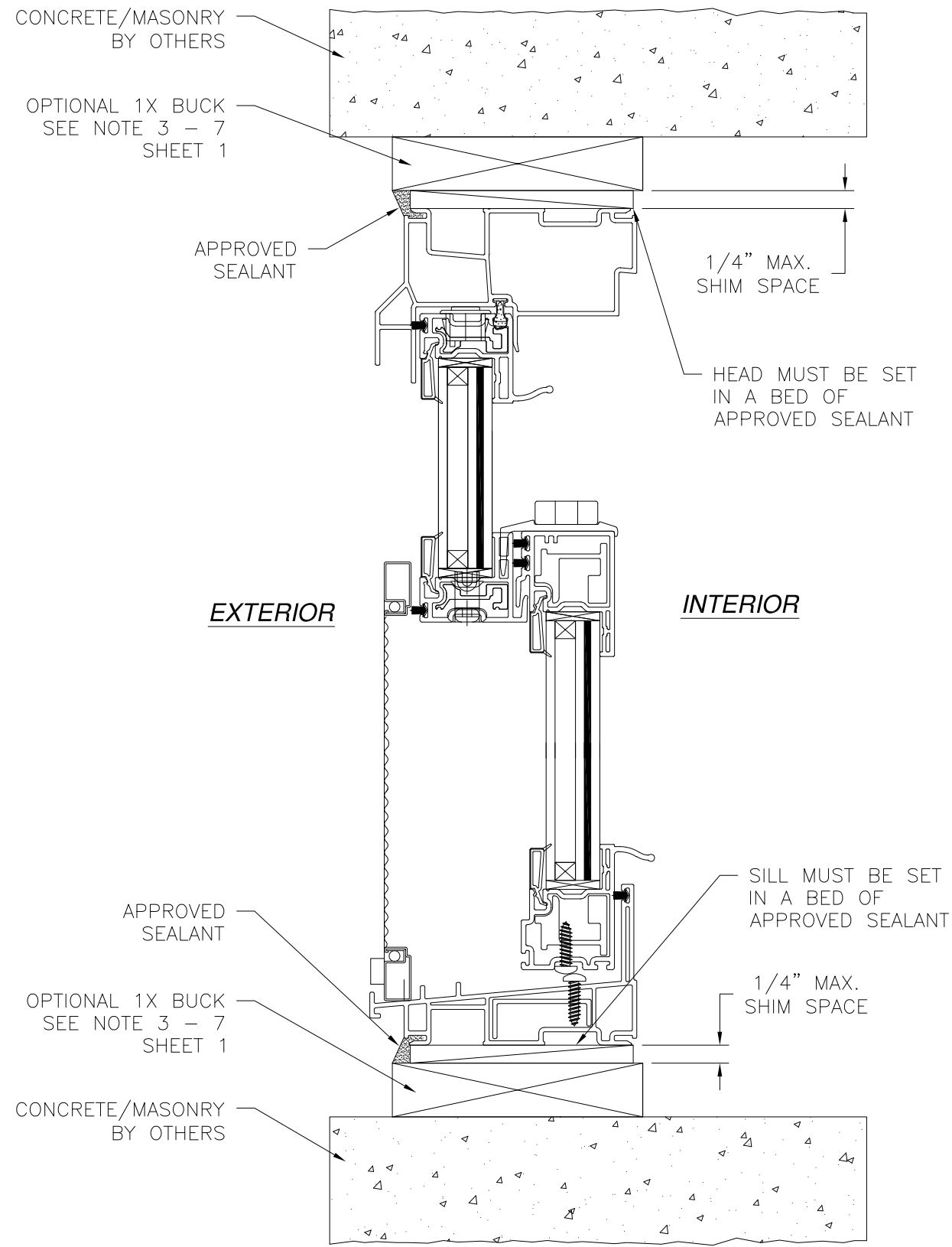

**VERTICAL CROSS SECTION
CONCRETE/MASONRY INSTALLATION**

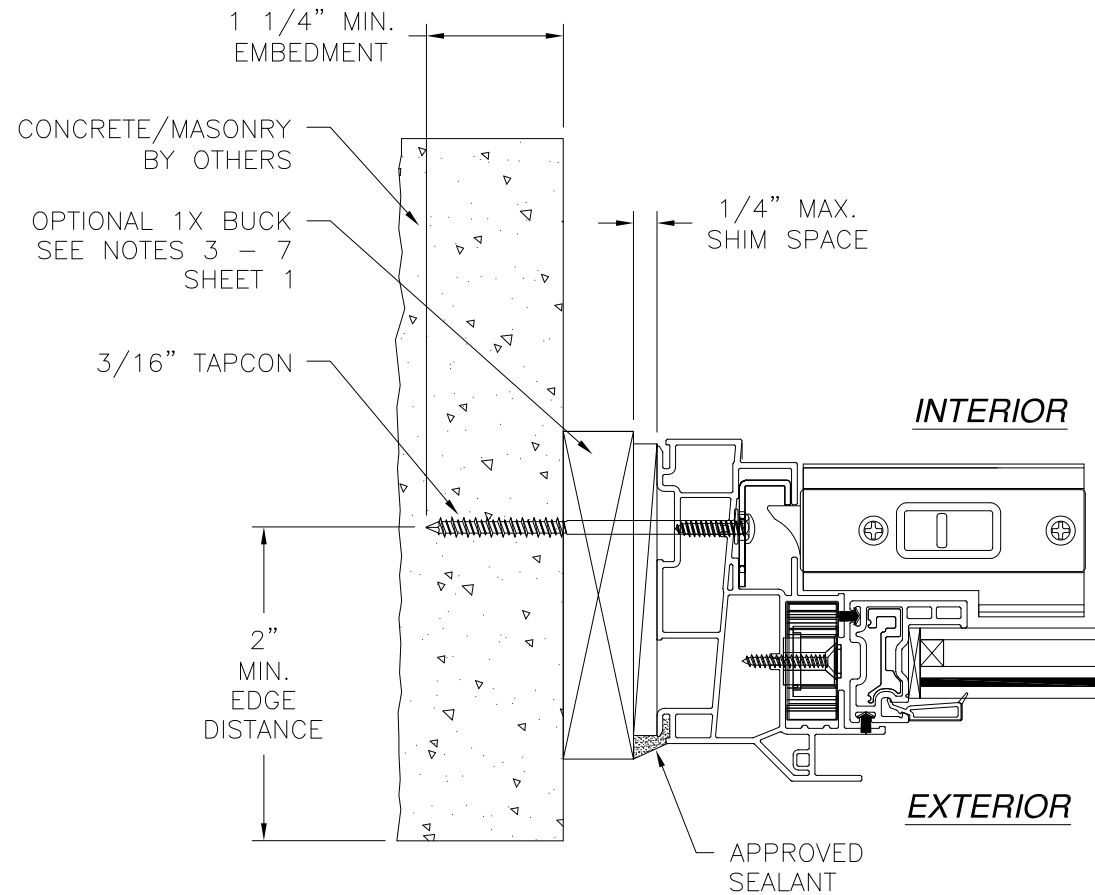

**JAMB INSTALLATION DETAIL
CONCRETE/MASONRY INSTALLATION**

- NOTES:**
1. INTERIOR AND EXTERIOR FINISHES, BY OTHERS, NOT SHOWN FOR CLARITY.
 2. PERIMETER AND JOINT SEALANT BY OTHERS TO BE DESIGNED IN ACCORDANCE WITH ASTM E2112

SIGNED: 07/30/2019

WINDOW MART 5760 ALBERT PIKE ROYAL, AR 71968		
SERIES 6201 NC/6202 REP VINYL DOUBLE HUNG WINDOW - IMPACT INSTALLATION DETAILS		
DRAWN: A.R.	DWG NO. 08-03478	REV -
SCALE NTS	DATE 07/25/19	SHEET 4 OF 6
L. ROBERTO LOMAS P.E. 1432 WOODFORD RD LEWISVILLE, NC 27023 434-688-0609 rllomas@rlomaspe.com		



Luis R. Lomas P.E.
TX No.: 101889

REVISIONS			
REV	DESCRIPTION	DATE	APPROVED

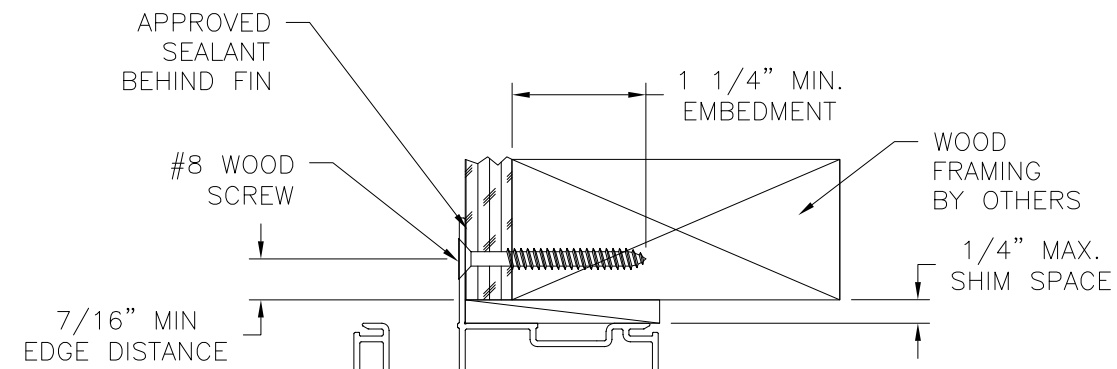

EXTERIOR

INTERIOR

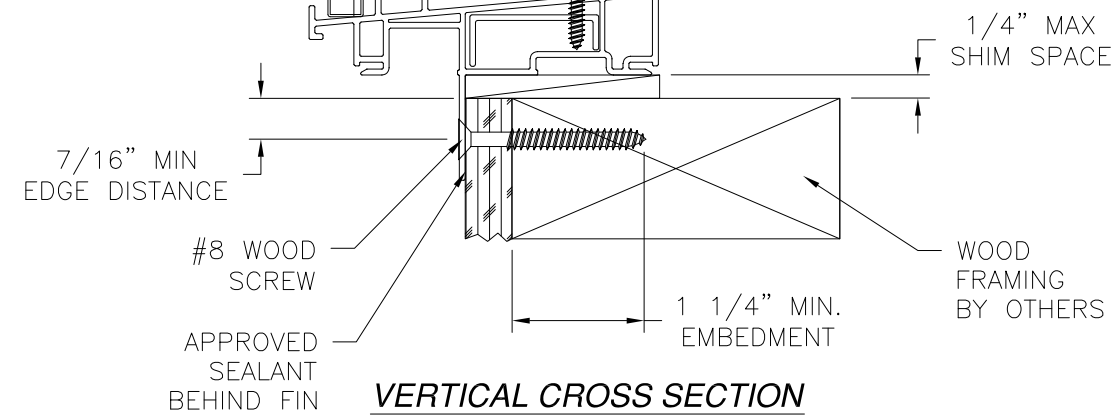

VERTICAL CROSS SECTION
WOOD FRAMING OR 2X BUCK INSTALLATION

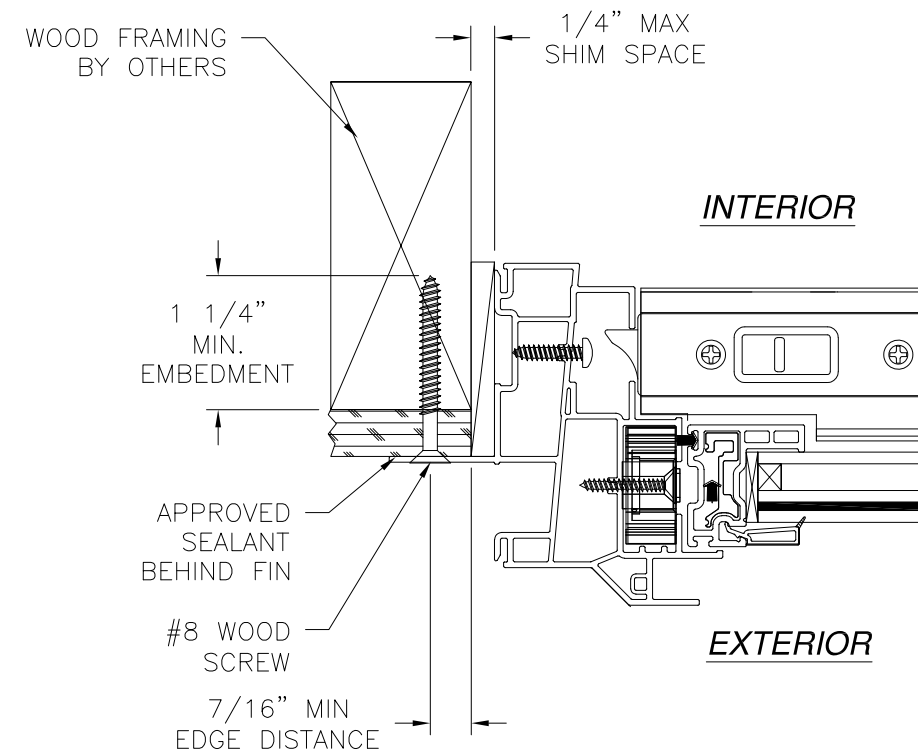

JAMB INSTALLATION DETAIL
WOOD FRAMING OR 2X BUCK INSTALLATION

- NOTES:**
1. INTERIOR AND EXTERIOR FINISHES, BY OTHERS, NOT SHOWN FOR CLARITY.
 2. PERIMETER AND JOINT SEALANT BY OTHERS TO BE DESIGNED IN ACCORDANCE WITH ASTM E2112

SIGNED: 07/30/2019

WINDOW MART 5760 ALBERT PIKE ROYAL, AR 71968		
SERIES 6201 NC/6202 REP VINYL DOUBLE HUNG WINDOW – IMPACT FIN INSTALLATION DETAILS		
DRAWN: A.R.	DWG NO. 08-03478	REV -
SCALE NTS	DATE 07/25/19	SHEET 5 OF 6
L. ROBERTO LOMAS P.E. 1432 WOODFORD RD LEWISVILLE, NC 27023 434-688-0609 rllomas@rlomaspe.com		



Luis R. Lomas P.E.
TX No.: 101889

REVISIONS			
REV	DESCRIPTION	DATE	APPROVED

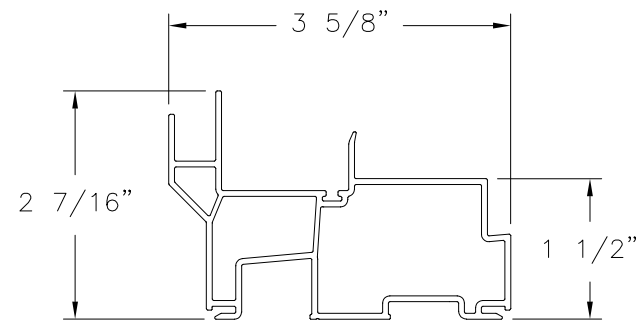

HEAD FRAME
EXTRUDED PVC (10008691)

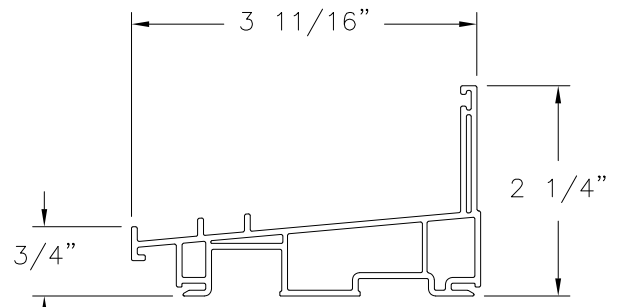

SILL FRAME
EXTRUDED PVC (10008692)

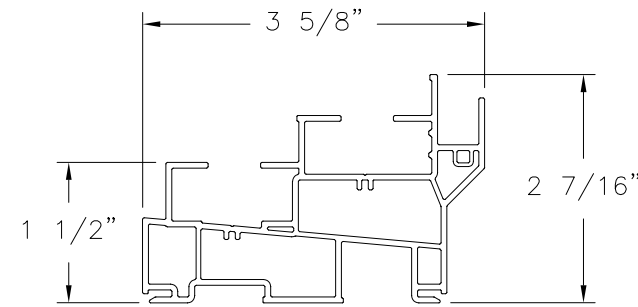

JAMB FRAME
EXTRUDED PVC (10008690)

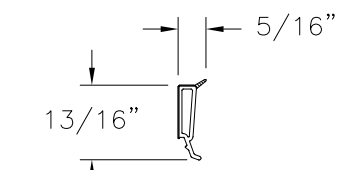

GLAZING BEAD
EXTRUDED PVC (10005470)

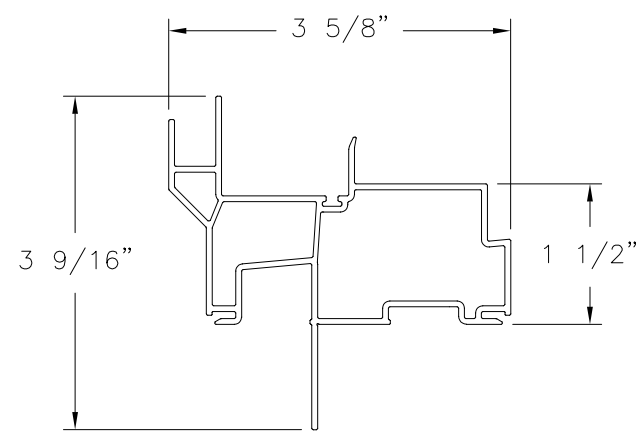

**HEAD FRAME
FIN INSTALLATION**
EXTRUDED PVC (10008671)

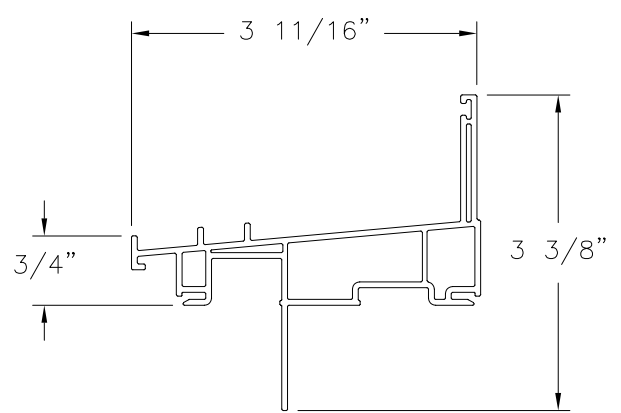

**SILL FRAME
FIN INSTALLATION**
EXTRUDED PVC (10008672)

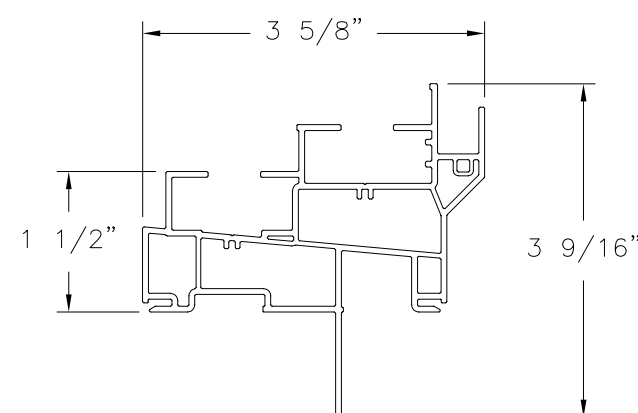

**JAMB FRAME
FIN INSTALLATION**
EXTRUDED PVC (10008670)

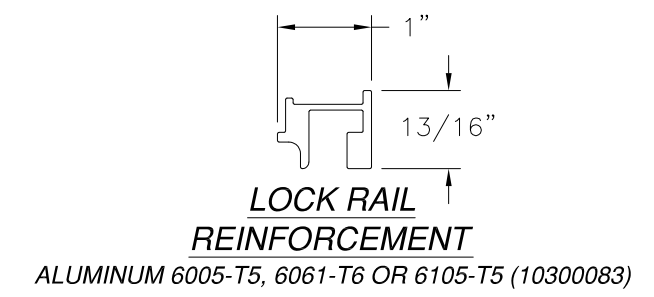

**LOCK RAIL
REINFORCEMENT**
ALUMINUM 6005-T5, 6061-T6 OR 6105-T5 (10300083)

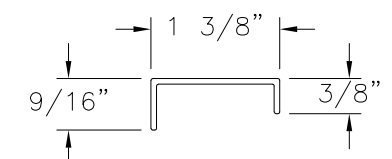

SILL REINFORCEMENT
ALUMINUM 6005-T5 (10300096)

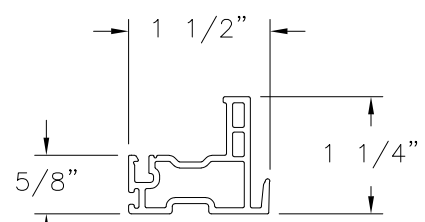

KEEPER RAIL
EXTRUDED PVC (10008890)

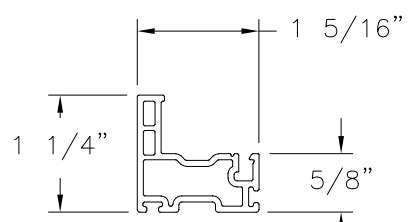

TOP STILE
EXTRUDED PVC (10008842)

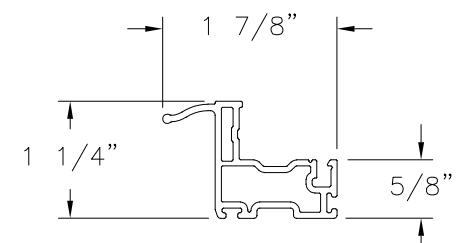

TOP LIFT RAIL
EXTRUDED PVC (10008840)

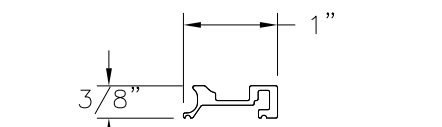

**SASH STILES & TOP RAILS
REINFORCEMENT**
ALUMINUM 6005-T5 (10300082)

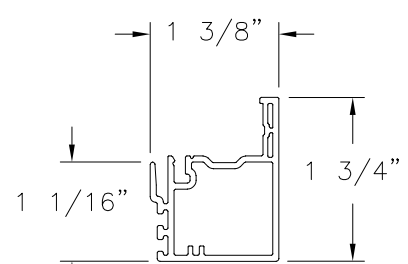

LOCK RAIL
EXTRUDED PVC (10008846)

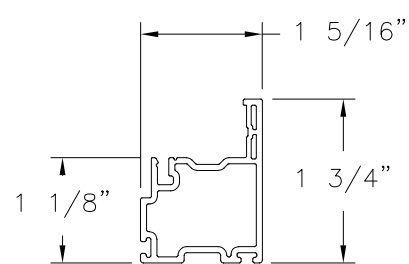

BOTTOM STILE
EXTRUDED PVC (10008843)

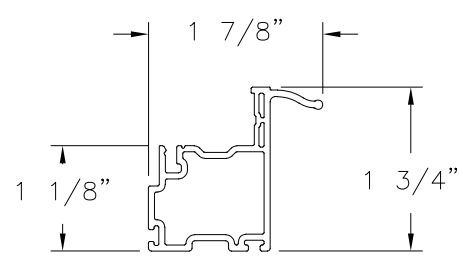

BOTTOM LIFT RAIL
EXTRUDED PVC (10008841)

SIGNED: 07/30/2019

WINDOW MART 5760 ALBERT PIKE ROYAL, AR 71968		
SERIES 6201 NC/6202 REP VINYL DOUBLE HUNG WINDOW - IMPACT COMPONENTS		
DRAWN: A.R.	DWG NO. 08-03478	REV -
SCALE NTS	DATE 07/25/19	SHEET 6 OF 6
L. ROBERTO LOMAS P.E. 1432 WOODFORD RD LEWISVILLE, NC 27023 434-688-0609 rllomas@rlomaspe.com		



Luis R. Lomas P.E.
TX No.: 101889