

# WINCORE™

## WINDOWS & DOORS

250 Staunton Turnpike, Parkersburg, WV 26104

### 8800 Series Vinyl Awning Window "IMPACT"

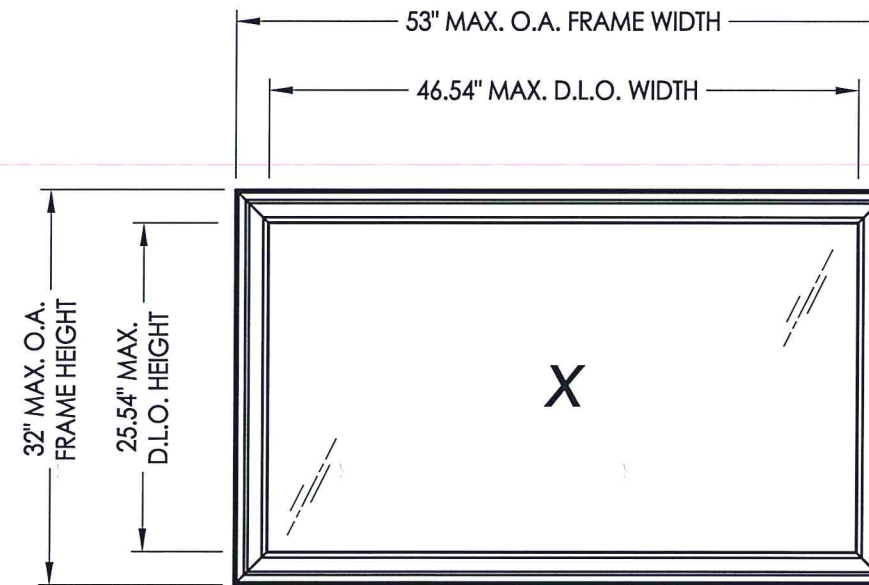

#### EVALUATED FOR USE IN THE STATE OF TEXAS

#### TDI WIN-1761

The Wincore Awning Window described herein complies with the 2006 International Residential Code (IRC), Sections R308.6 and the 2006 International Building Code (IBC), Sections 1405.12, 1609, 1714.5, 2403 and 2404 (including Texas revisions) subject to the following conditions:

1. Anchors shall be as listed and spaced as shown in the details. Anchor embedment to base material shall be beyond roof covering.
2. When used in areas requiring wind-borne debris protection, this product complies with Section R301.2.1.2 of the IRC and Section 1609.1.2 of the IBC and does not require impact protection. This product meets missile level "D" and includes Wind Zone 4 as defined in ASTM E 1996.
3. Allowable design pressure requirements must be equal to or less than the design pressure rating shown in the design pressure chart, sheet 1 of this drawing.
4. Conditions not covered by this drawing are subject to further engineering analysis.

#### TABLE OF CONTENTS

SHEET#	DESCRIPTION
1	Typical elevations, design pressures and general notes
2	Vertical & horizontal cross sections
3	Frame anchoring
4	Bill of materials, components & glazing details

MAX. FRAME DIMENSION	MAX. D.L.O. DIMENSION	GLASS TYPE	DESIGN PRESSURE (PSF)	
			POSITIVE	NEGATIVE
53.0" X 32.0"	46.54" X 25.54"	G1, G2	+65.0	-70.0

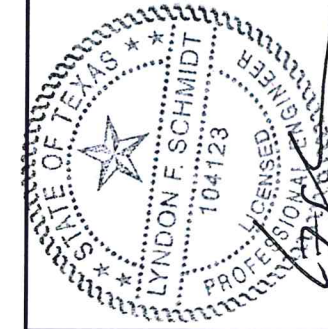

Documents Prepared By: Lyndon F. Schmidt, P.E.  
TEXAS P.E. #104123

**RW** BUILDING CONSULTANTS, INC.  
P.O. Box 230 Valrico FL 33595  
Phone No.: 813.659.9197  
TEXAS BOARD OF PROFESSIONAL ENGINEERS  
CERTIFICATE OF REGISTRATION # F-11852

PRODUCT: 8800 SERIES Vinyl Awning Window  
PART OR ASSEMBLY: TYPICAL ELEVATION, DESIGN PRESSURES & GENERAL NOTES

NO.	DATE	REVISIONS
1	1/16/20	UPDATE TO 2018 IBC/IRC & REVISE D.P. TABLE/ANCHORING

DATE: 9/10/12

SCALE: N.T.S.

DWG. BY: JK

CHK. BY: LFS

DRAWING NO.:

TX-4241

SHEET 1 OF 4

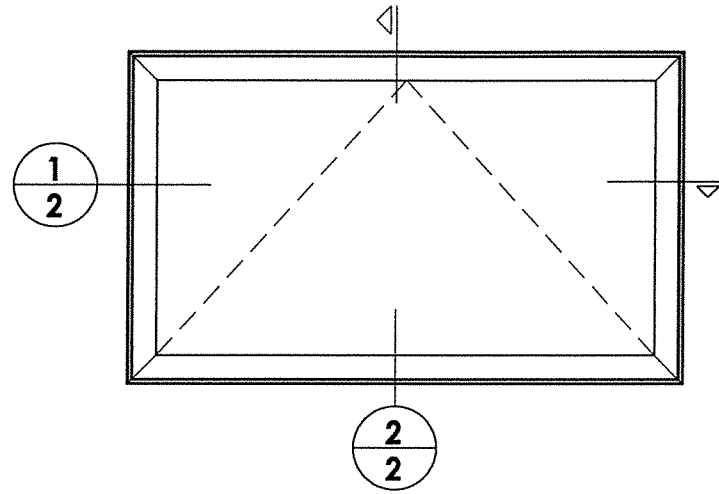

**NOTES:**

1. Locks located 9" up from frame bottom of each stile (2 total).
2. Item L located in one hole of tie bar guide (1 total per guide).
3. Item G located in outside holes of operator base (2 total).
4. Item K located in one hole of snubber (1 total per snubber).

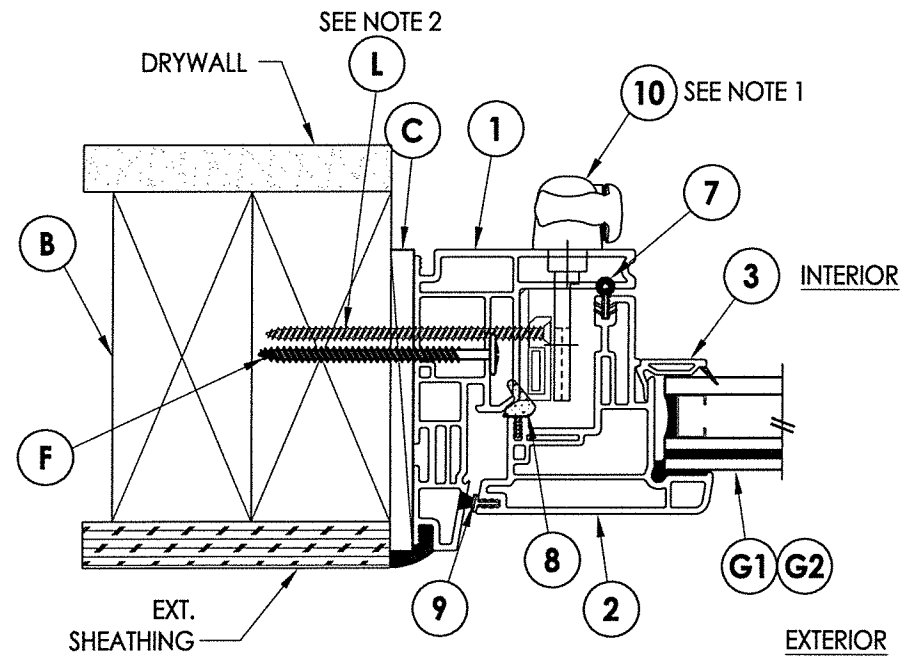

**1 HORIZONTAL CROSS SECTION**  
**2** Shown w/ 2X buck

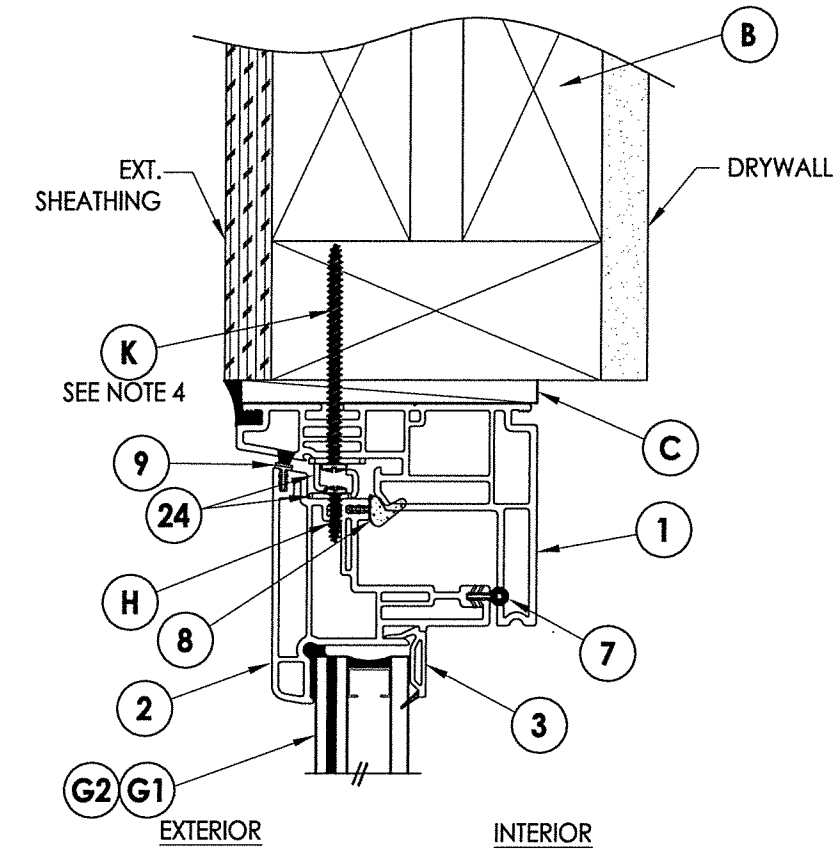

**2 VERTICAL CROSS SECTION**

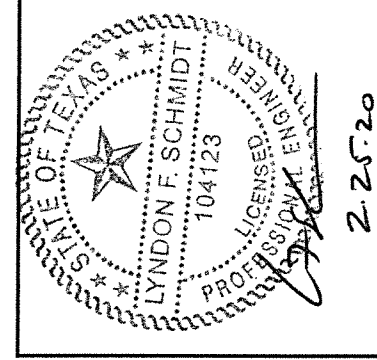
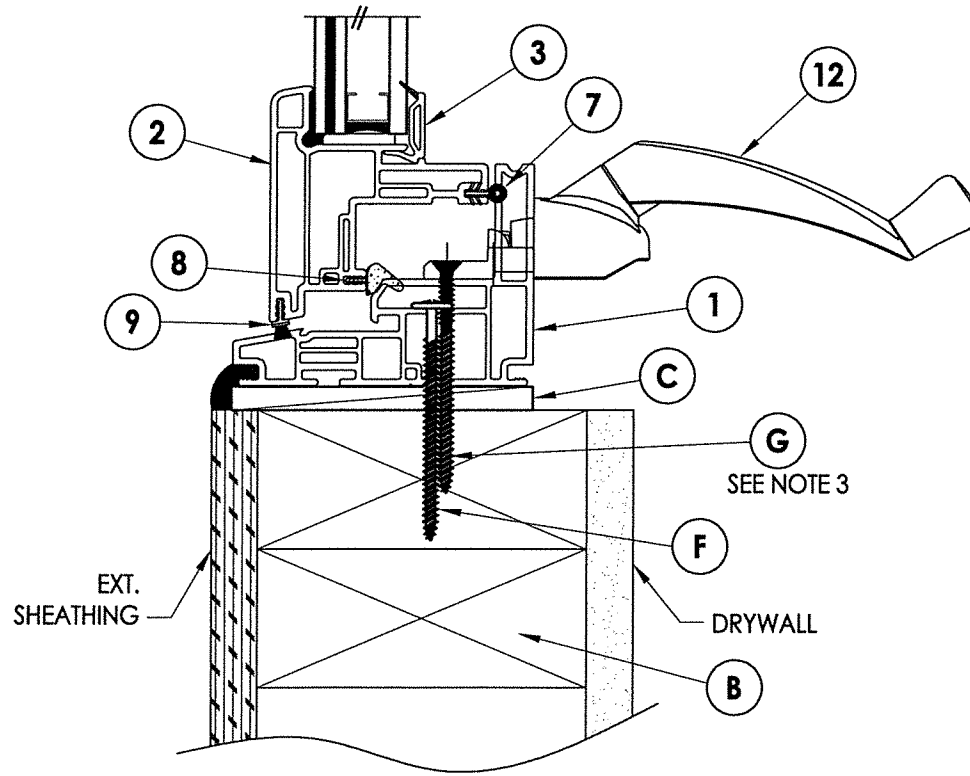

Documents Prepared By: Lyndon F. Schmidt, P.E.  
 TEXAS P.E. #104123

**RW** BUILDING CONSULTANTS, INC.  
 P.O. Box 230 Valrico FL 33595  
 Phone No.: 813.659.9197

TEXAS BOARD OF PROFESSIONAL ENGINEERS  
 CERTIFICATE OF REGISTRATION # F-11852

PRODUCT: 8800 SERIES Vinyl Awning Window  
 PART OR ASSEMBLY: VERTICAL & HORIZONTAL CROSS SECTIONS

NO.	DATE	REVISIONS	BY
1	1/16/20	UPDATE TO 2018 IBC/IRC & REVISE D.P. TABLE/ANCHORING	LFS

DATE: 9/10/12  
 SCALE: N.T.S.  
 DWG. BY: JK  
 CHK. BY: LFS  
 DRAWING NO.: TX-4241  
 SHEET 2 OF 4

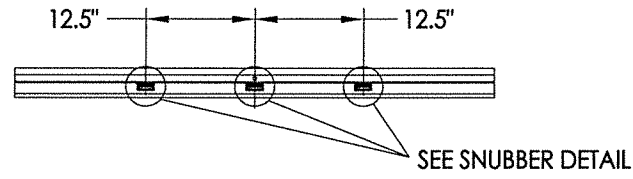

**SNUBBER LOCATIONS**  
3 Req'd

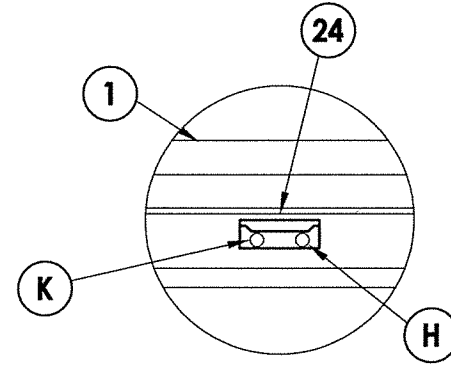

**SNUBBER DETAIL**

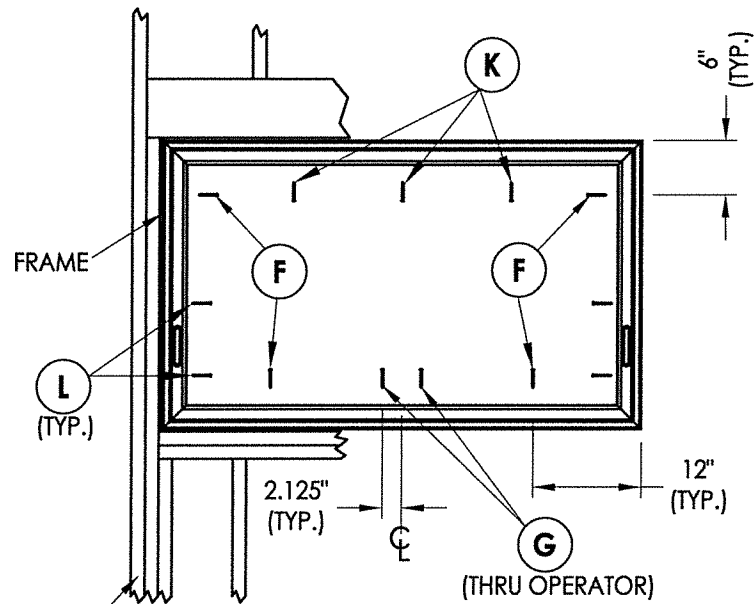

**FRAME ANCHORING**

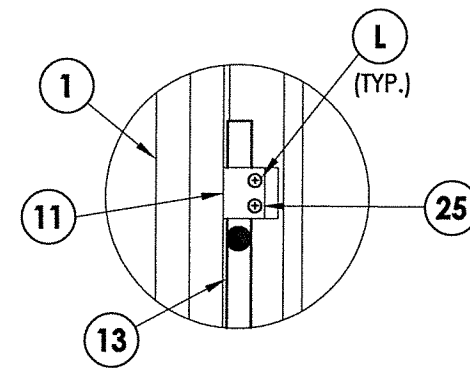

**TIE BAR GUIDE DETAIL**

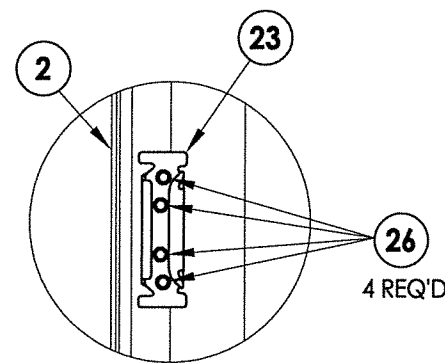

**KEEPER DETAIL**

Located 4" above bottom of each sash

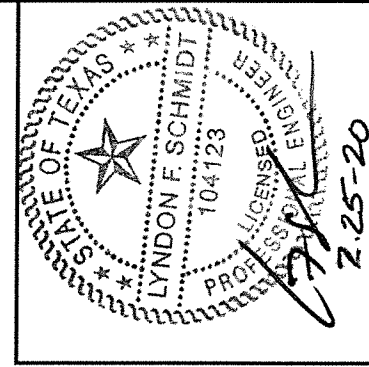

Documents Prepared By: Lyndon F. Schmidt, P.E.  
TEXAS P.E. #104123

**RW** BUILDING CONSULTANTS, INC.  
P.O. Box 230 Valrico FL 33595  
Phone No.: 813.659.9197  
TEXAS BOARD OF PROFESSIONAL ENGINEERS  
CERTIFICATE OF REGISTRATION # F-11852

PRODUCT:	Vinyl Awning Window
PART OR ASSEMBLY:	FRAME ANCHORING

NO.	DATE	BY	REVISIONS
1	1/16/20	LFS	UPDATE TO 2018 IBC/IRC & REVISE D.P. TABLE/ANCHORING

DATE:	9/10/12
SCALE:	N.T.S.
DWG. BY:	JK
CHK. BY:	LFS
DRAWING NO.:	TX-4241
SHEET	3 OF 4

BILL OF MATERIALS		
ITEM #	DESCRIPTION	MATERIAL
B	2X FRAMING (SG >= 0.42)	WOOD
C	1/4" MAX. SHIM SPACE	-
F	#8 X 2-1/2" MODIFIED TRUSS HEAD (7/16" Ø) SMS (1-3/8" MIN. EMBEDMENT)	STEEL
G	#8 X 2-1/2" PFH WOOD SCREW (7/8" MIN. EMB.)	STEEL
H	#8 X 1/2" PPH SMS	STEEL
1	FRAME*	PVC
2	SASH *	PVC
3	GLAZING BEAD*	PVC
7	WEATHERSTRIP AMESBURY (CS 120 33-SEAL)	FOAM
8	WEATHERSTRIP AMESBURY (12300 SEAL)	VINYL
9	WEATHERSTRIP ULTRA FAB .250 (PILE - 250 - KP52)	VINYL
10	MULTI-POINT LOCK (TRUTH) 24.33.32.004	-
11	TIE BAR GUIDE (TRUTH)	-
12	OPERATOR (TRUTH) 50.10.00.011	-
23	KEEPER (TRUTH)	STEEL
24	SNUBBER (TRUTH) (SASH/FRAME) 22999	STEEL
26	#8 X 1/2" TRUSS HEAD SMS	STEEL

\* THE APPROVED WHITE RIGID PVC EXTERIOR EXTRUSIONS FOR WINDOWS ARE TO BE PRODUCED BY EXTRUDERS LICENSEES IN "CERTIFICATION PROGRAMS FOR RIGID PVC EXTRUSIONS".

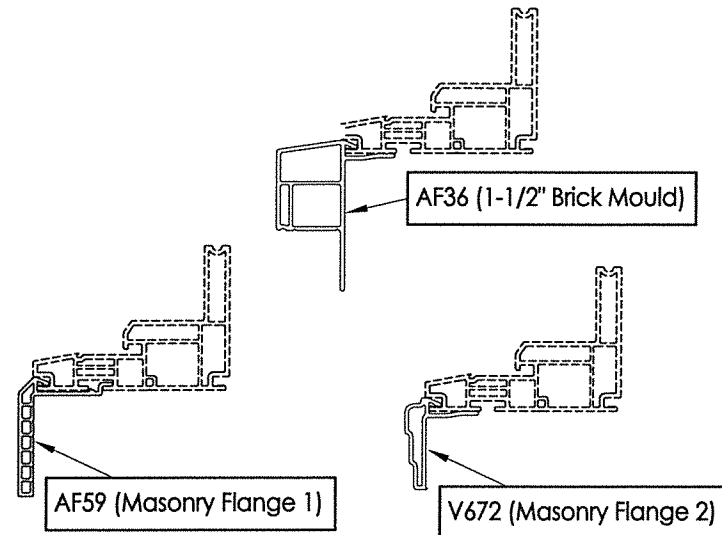
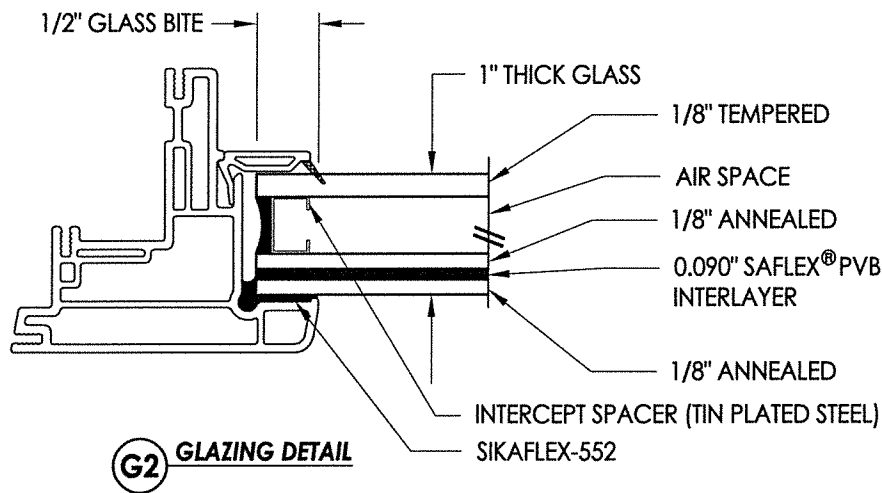
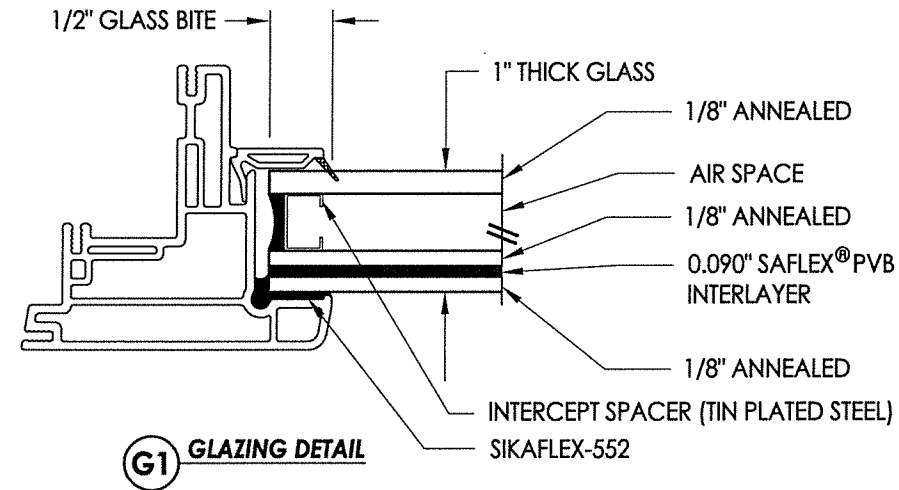

**OPTIONAL COSMETIC FLANGES**

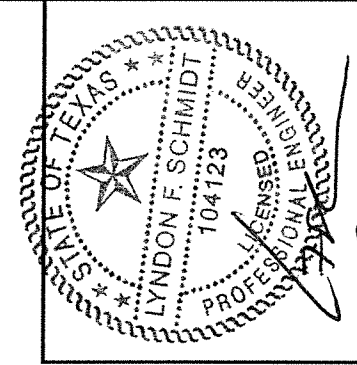
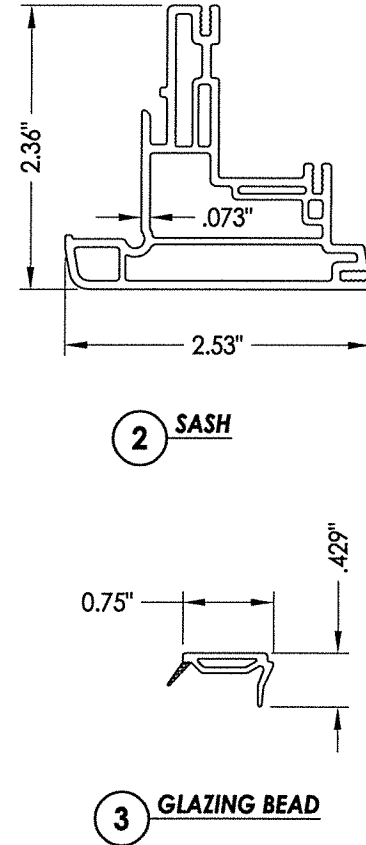
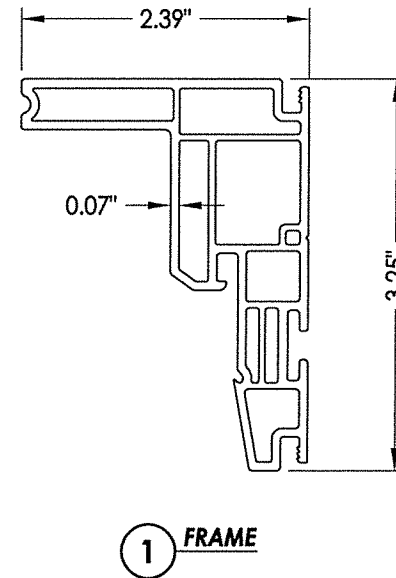

Documents Prepared By: Lyndon F. Schmidt, P.E.  
TEXAS P.E. #104123

**RW** BUILDING CONSULTANTS, INC.  
P.O. Box 230 Valrico FL, 33595  
Phone No.: 813.659.9197

TEXAS BOARD OF PROFESSIONAL ENGINEERS  
CERTIFICATE OF REGISTRATION # F-11852

PRODUCT: 8800 SERIES Vinyl Awning Window  
PART OR ASSEMBLY: BILL OF MATERIALS, COMPONENTS & GLAZING DETAILS

NO.	DATE	REVISIONS
1	1/16/20	UPDATE TO 2018 IBC/IRC & REVISE D.P. TABLE/ANCHORING
2		SASH
3		GLAZING BEAD

DATE: 9/10/12  
SCALE: N.T.S.  
DWG. BY: JK  
CHK. BY: LFS  
DRAWING NO.: TX-4241  
SHEET 4 OF 4