

# WINCORE™

## WINDOWS & DOORS

250 Staunton Turnpike, Parkersburg, WV 26104

### 8400 Series Vinyl Fixed Window "NON-IMPACT"

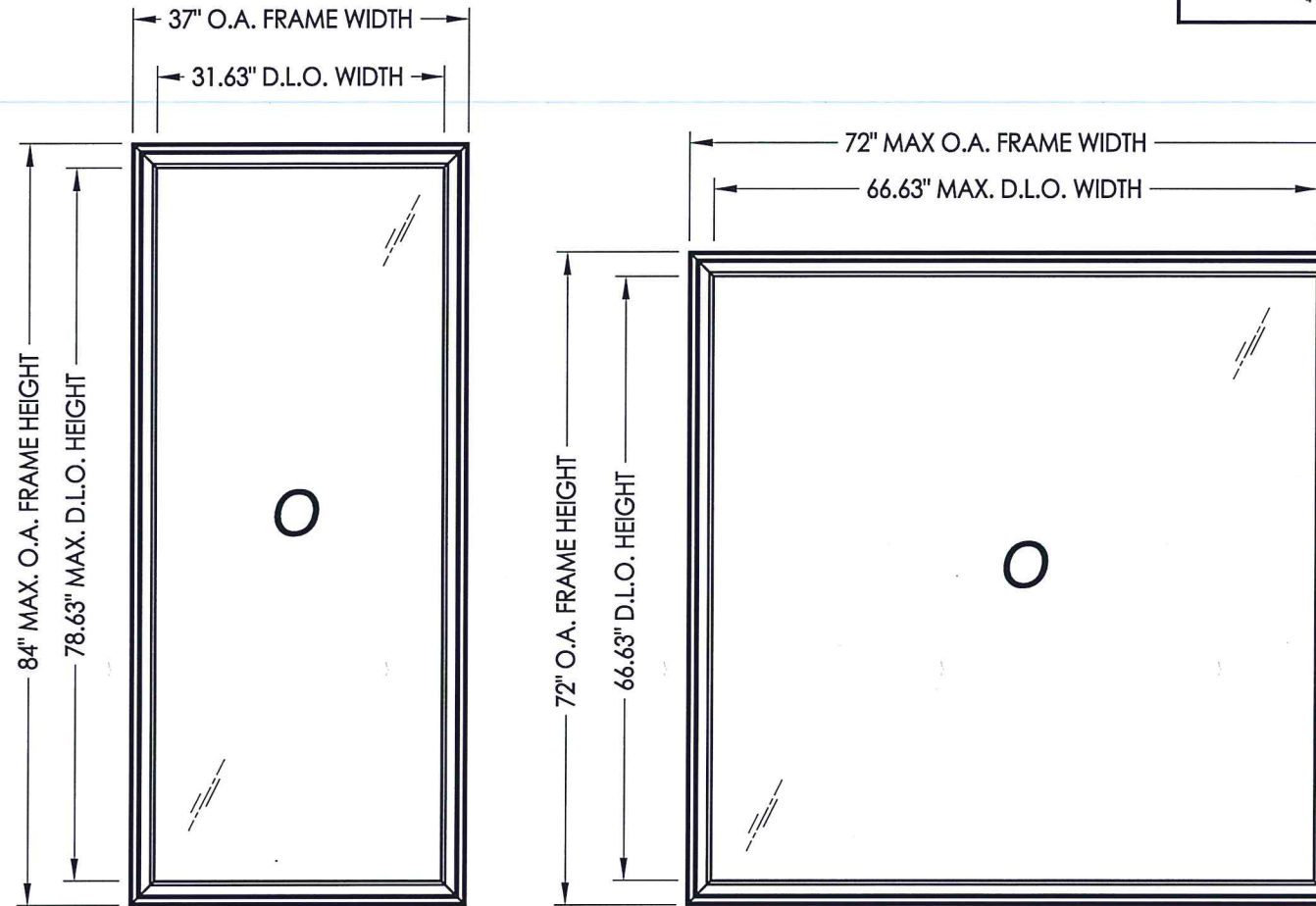

EVALUATED FOR USE IN THE STATE OF TEXAS

**TDI WIN-1749**

The Wincore Fixed Window described herein complies with the 2018 International Residential Code (IRC), Sections R301 & R609 and the 2018 International Building Code (IBC), Sections 1404.13, 1609, 1709.5, 2403 and 2404 subject to the following conditions:

1. Anchors shall be as listed and spaced as shown in the details. Anchor embedment to base material shall be beyond wall dressing or stucco.
2. When used in areas requiring wind-borne debris protection this product is required to be protected with an impact resistant covering that complies with Section R301.2.1.2 of the IRC and Section 1609.1.2 of the IBC.
3. Allowable design pressure requirements must be equal to or less than the design pressure rating shown in the design pressure chart, sheet 1 of this drawing.
4. Conditions not covered by this drawing are subject to further engineering analysis.

TABLE OF CONTENTS	
SHEET#	DESCRIPTION
1	Typical elevations, design pressures and general notes
2	Horizontal cross sections
3	Frame anchoring
4	Frame anchoring
5	Bill of materials, components and glazing details

MAX. FRAME DIMENSION	MAX. D.L.O. DIMENSION	GLASS TYPE	DESIGN PRESSURE (PSF)	
			POSITIVE	NEGATIVE
37.0" X 84.0"	31.63" X 78.63"	G2	+65.0	-65.0
48.0" X 60.0"	42.63" X 54.63"	G1	+50.0	-50.0
64.0" X 64.0"	58.63" X 58.63"	G3	+65.0	-65.0
72.0" X 72.0"	66.63" X 66.63"	G3	+50.0	-50.0
		G2	+55.0	-65.0
76.0" X 63.0"	70.63" X 57.63"	G4	+80.0	-80.0

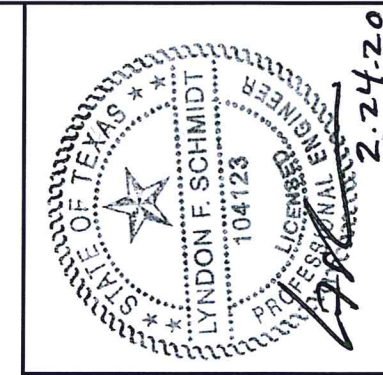

Documents Prepared By: Lyndon F. Schmidt, P.E.  
TEXAS P.E. #104123

**RW** BUILDING CONSULTANTS, INC.  
P.O. Box 230 Vairico FL 33595  
Phone No.: 813.659.9197

TEXAS BOARD OF PROFESSIONAL ENGINEERS  
CERTIFICATE OF REGISTRATION # F-11852

PRODUCT:	8400 SERIES VINYL FIXED WINDOW	
PART OR ASSEMBLY:	TYPICAL ELEVATION, DESIGN PRESSURES & GENERAL NOTES	
NO.	DATE	BY
2	1/21/20	LFS
1	8/27/13	JK
REVISIONS		
DATE:	9/10/12	
SCALE:	N.T.S.	
DWG. BY:	JK	
CHK. BY:	LFS	
DRAWING NO.:	TX-4236	
SHEET	1 OF 5	



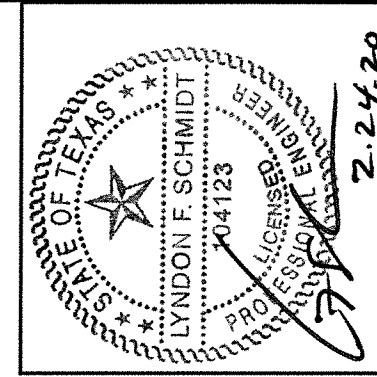

Documents Prepared By: Lyndon F. Schmidt, P.E.  
 TEXAS P.E. #104123

**RW** BUILDING CONSULTANTS, INC.  
 P.O. Box 230 Vairico FL 33595  
 Phone No.: 813.659.9197

TEXAS BOARD OF PROFESSIONAL ENGINEERS  
 CERTIFICATE OF REGISTRATION # F-11852

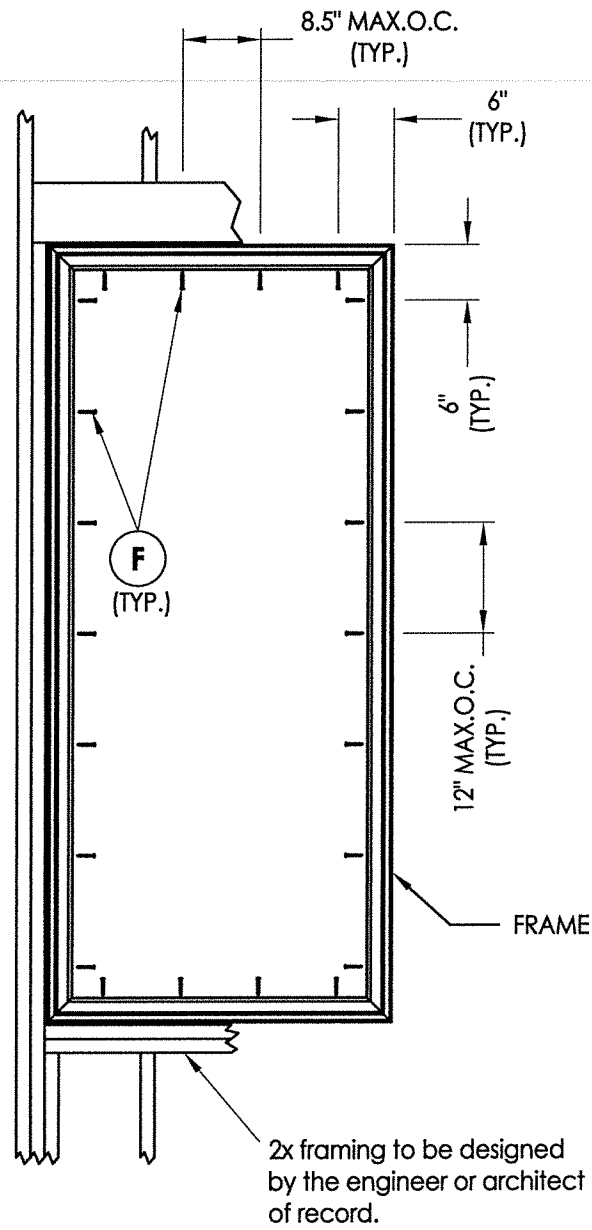

**FRAME ANCHORING**  
 37" X 84" MAX

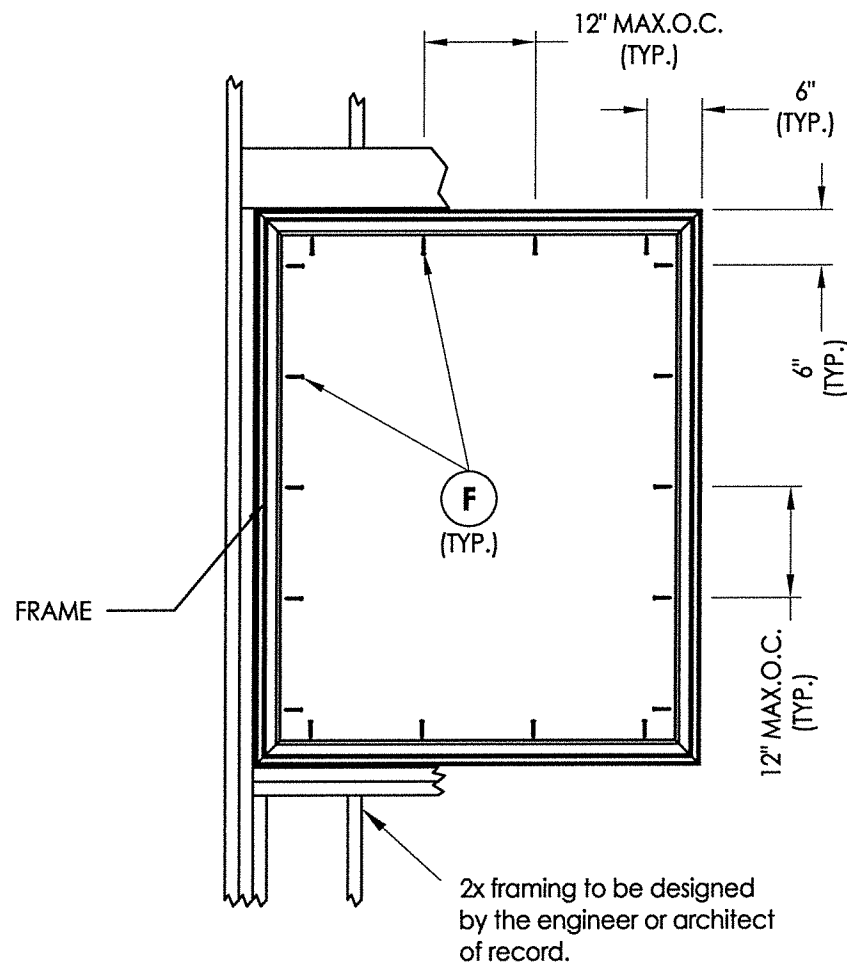

**FRAME ANCHORING**  
 48" X 60" MAX

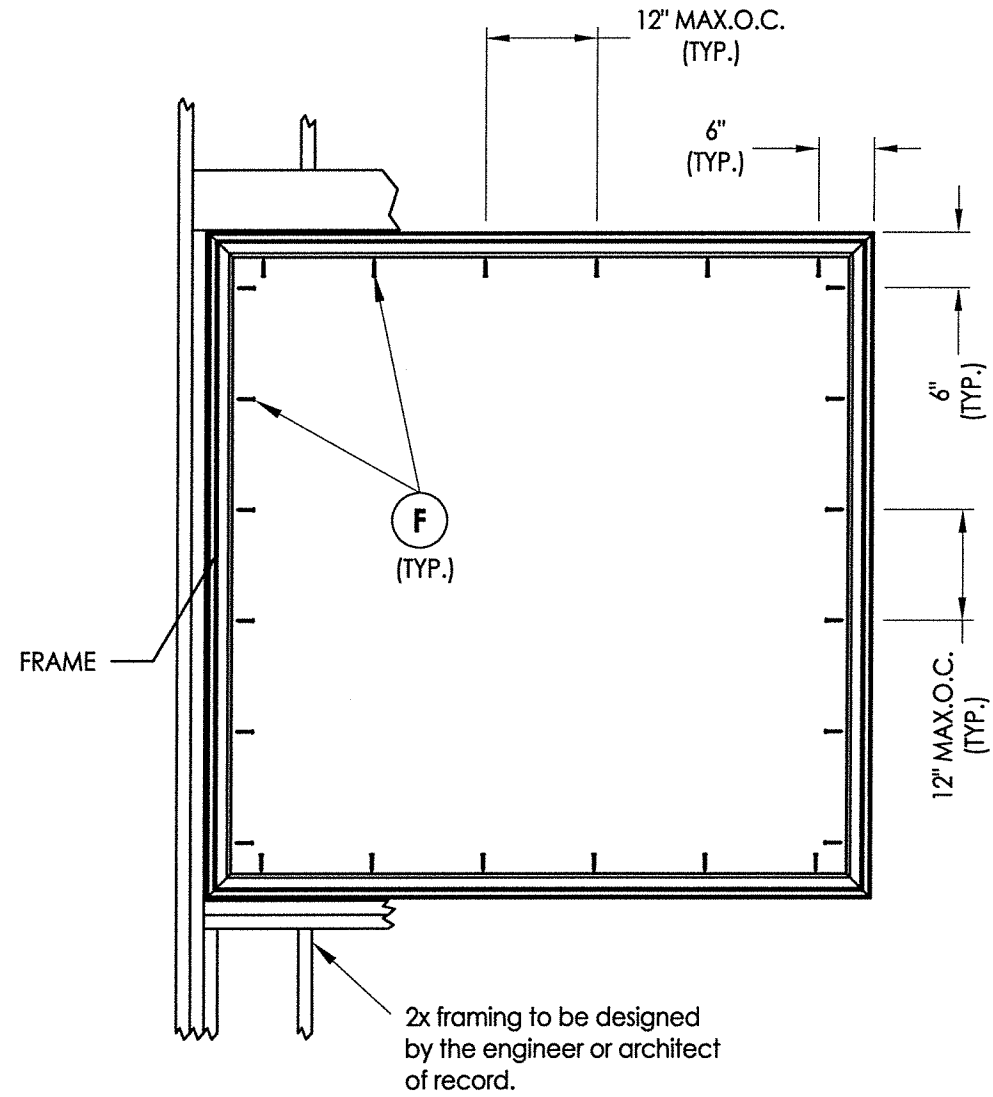

**FRAME ANCHORING**  
 72" X 72" MAX

PRODUCT:		8400 SERIES VINYL FIXED WINDOW	
PART OR ASSEMBLY:		FRAME ANCHORING	
NO.	DATE	BY	REVISIONS
2	1/21/20	LFS	UPDATE TO 2018 IBC/IRC
1	8/27/13	JK	ADDED NEW FRAME SIZE
DATE:		9/10/12	
SCALE:		N.T.S.	
DWG. BY:		JK	
CHK. BY:		LFS	
DRAWING NO.:		TX-4236	
SHEET		3 OF 5	

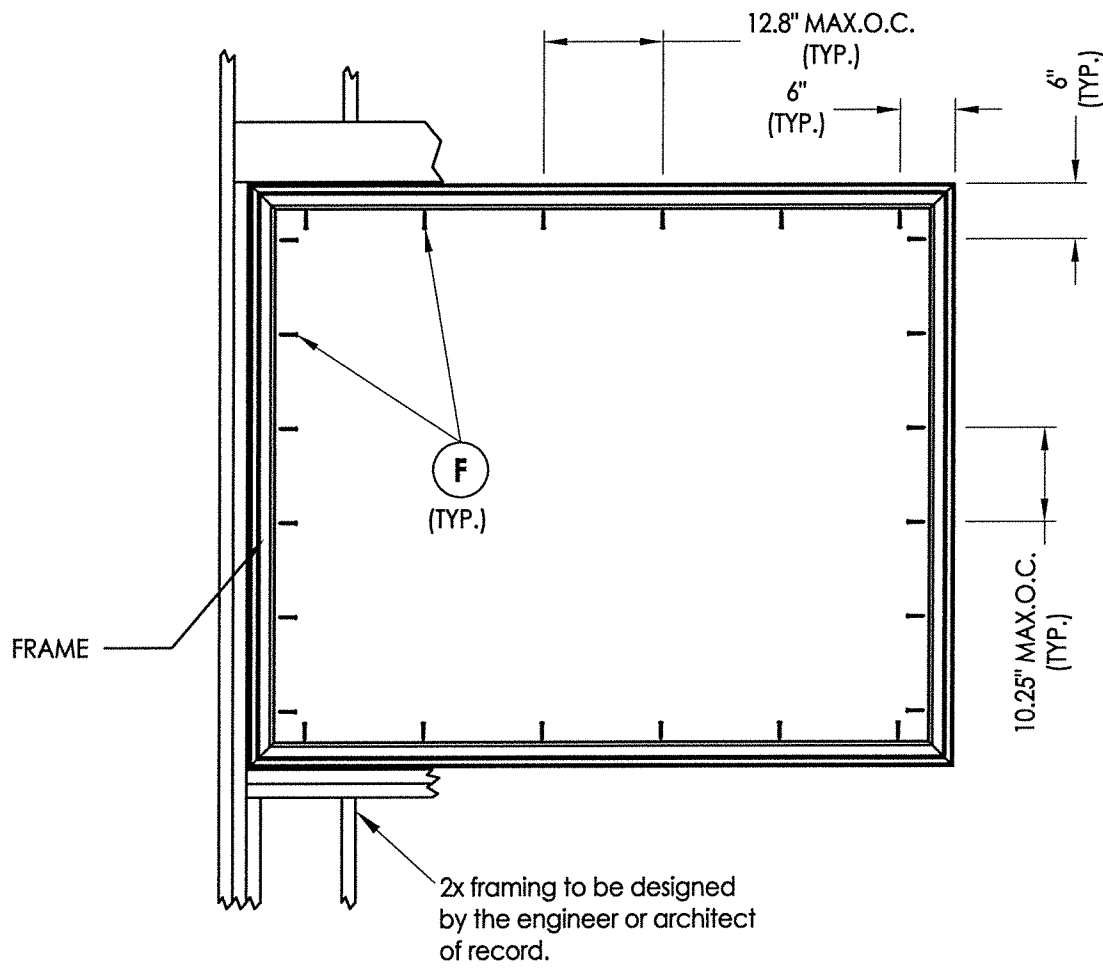

**FRAME ANCHORING**  
76\"/>

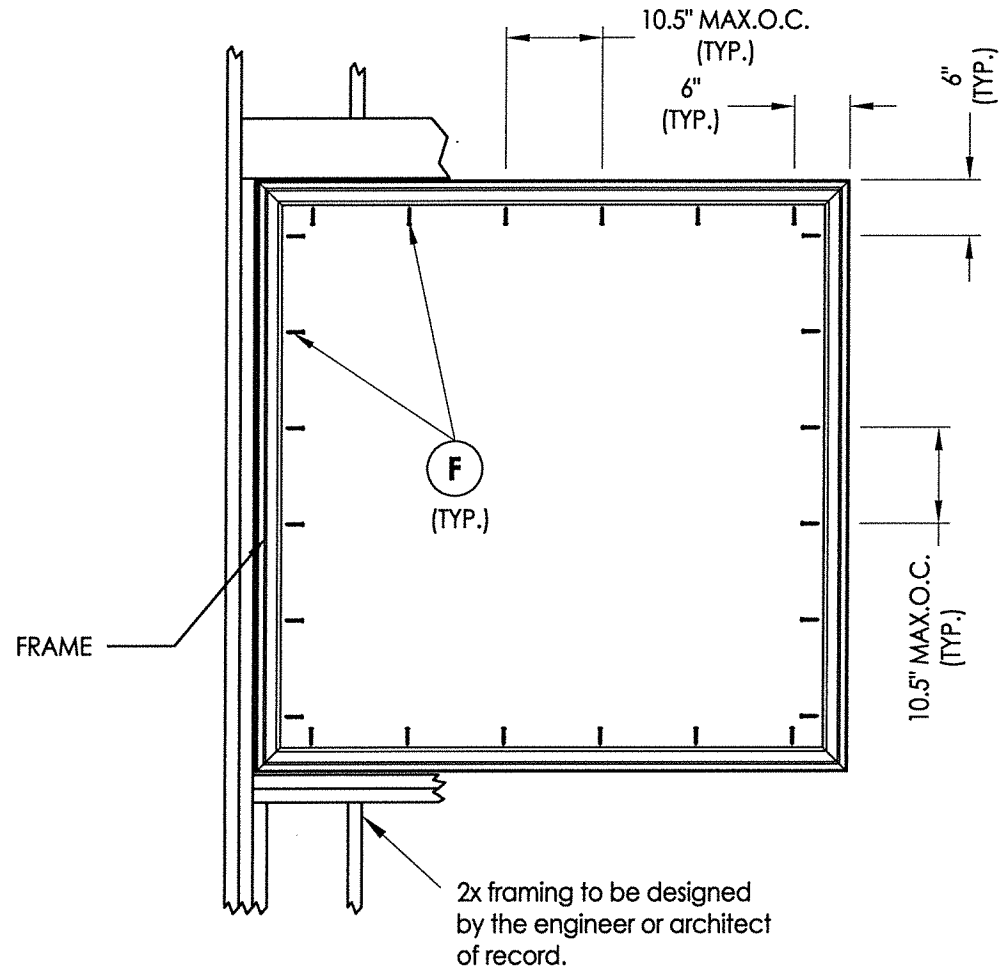

**FRAME ANCHORING**  
64\"/>

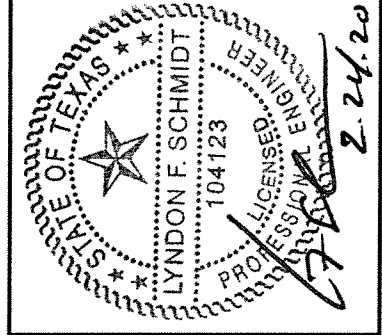

Documents Prepared By: Lyndon F. Schmidt, P.E.  
TEXAS P.E. #104123

**RW** BUILDING CONSULTANTS, INC.  
P.O. Box 230 Valrico FL 33595  
Phone No.: 813.669.9197

TEXAS BOARD OF PROFESSIONAL ENGINEERS  
CERTIFICATE OF REGISTRATION # F-11852

PRODUCT:  
8400 SERIES  
VINYL FIXED WINDOW

PART OR ASSEMBLY:

FRAME ANCHORING

NO.	DATE	REVISIONS
2	1/21/20	UPDATE TO 2018 IBC/IRC
1	8/27/13	ADDED NEW FRAME SIZE
		LFS
		JK
		BY

DATE: 9/10/12

SCALE: N.T.S.

DWG. BY: JK

CHK. BY: LFS

DRAWING NO.:

TX-4236

SHEET 4 OF 5

R:\Clients\Wincore PERMANENT\B - (2018) Texas Dept of Ins\WIN 1749 - Fixed 8400\C - Drawings\2018 IBC UPDATE\TX-4236.dwg, 5.1

BILL OF MATERIALS		
ITEM #	DESCRIPTION	MATERIAL
B	2X BUCK SG >= 0.42	WOOD
C	1/4" MAX. SHIM SPACE	-
F	#10 X 1-3/4" PPH WOOD SCREW (1-3/16" MIN. EMBEDMENT)	STEEL
1	FRAME (PI7701WH)*	PVC
2	1" GLAZING BEAD (BV56WH)*	PVC

\* THE APPROVED WHITE RIGID PVC EXTERIOR EXTRUSIONS FOR WINDOWS ARE TO BE PRODUCED BY EXTRUDERS LICENSEES IN "AAMA CERTIFICATION PROGRAMS FOR RIGID PVC EXTRUSIONS".

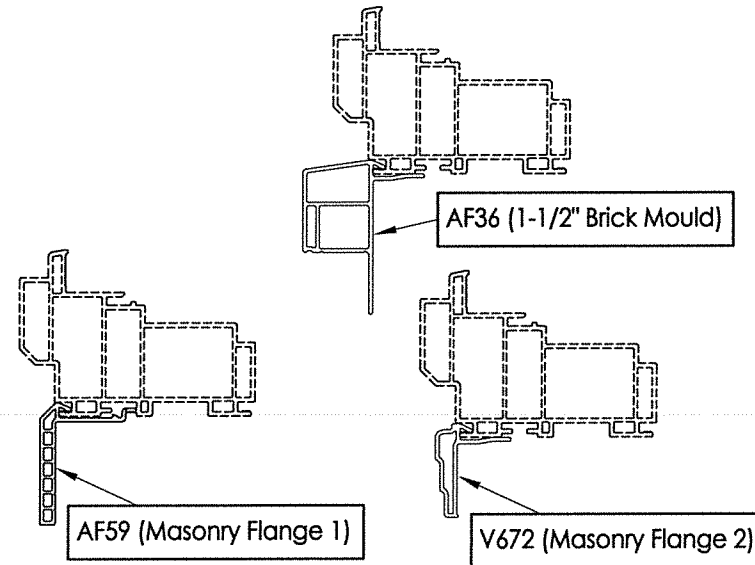

**OPTIONAL COSMETIC FLANGES**

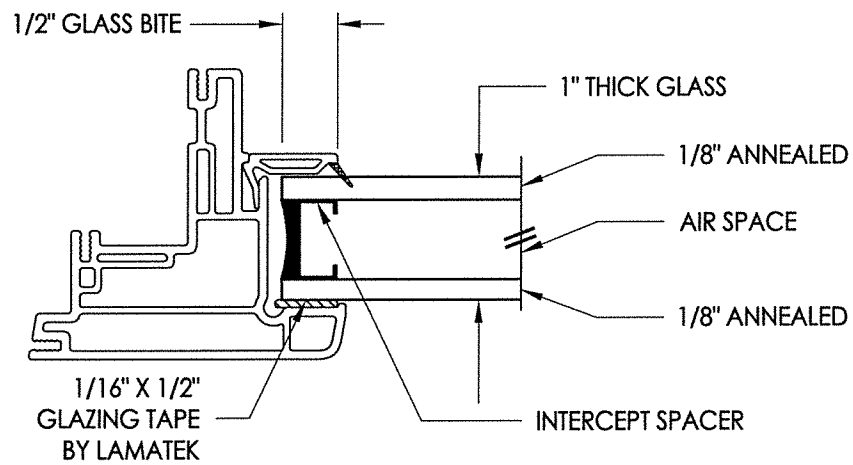

**G1 GLAZING DETAIL**

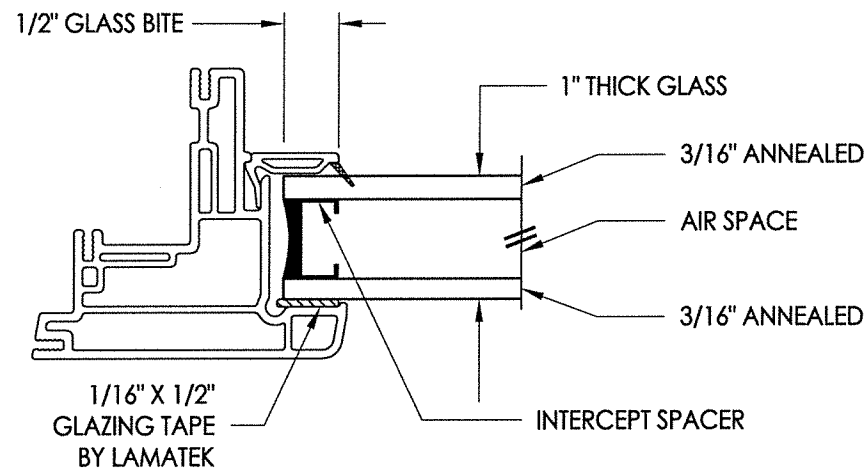

**G3 GLAZING DETAIL**

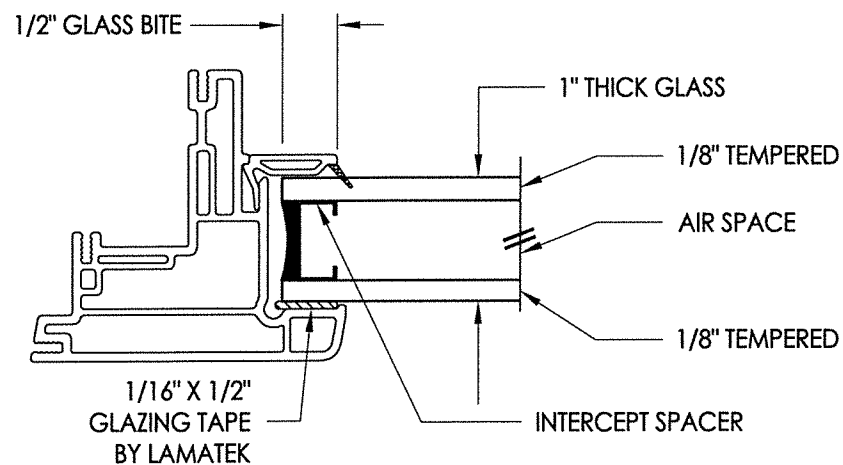

**G2 GLAZING DETAIL**

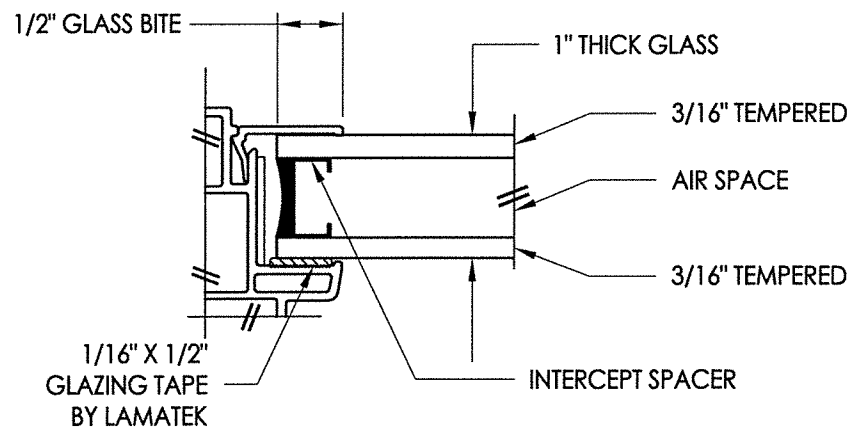

**G4 GLAZING DETAIL**

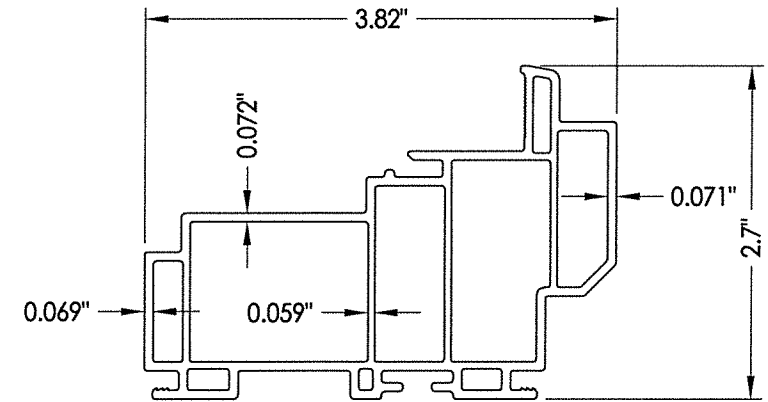

**1 FRAME**

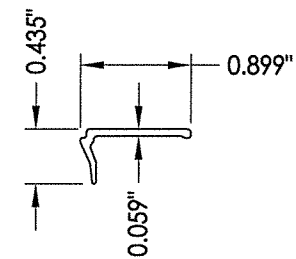

**2 GLAZING BEAD**

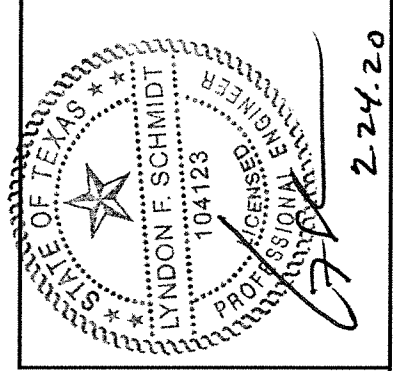

2-24-20

Documents Prepared By: Lyndon F. Schmidt, P.E.  
TEXAS P.E. #104123

**RW** BUILDING CONSULTANTS, INC.  
P.O. Box 230 Valrico FL 33595  
Phone No.: 813.659.9197

TEXAS BOARD OF PROFESSIONAL ENGINEERS  
CERTIFICATE OF REGISTRATION # F-11852

PRODUCT:	8400 SERIES VINYL FIXED WINDOW
PART OR ASSEMBLY:	BILL OF MATERIALS, COMPONENTS AND GLAZING DETAIL

NO.	DATE	BY	REVISIONS
2	1/21/20	LFS	UPDATE TO 2018 IBC/IRC
1	8/27/13	JK	ADDED NEW FRAME SIZE

DATE:	9/10/12
SCALE:	N.T.S.
DWG. BY:	JK
CHK. BY:	LFS
DRAWING NO.:	TX-4236
SHEET	5 OF 5

© 2012 R.W. BUILDING CONSULTANTS INC.