

REVISIONS			
REV	DESCRIPTION	DATE	APPROVED
C	REVISED PER NEW REQUIREMENTS	07/21/2022	R.L.

NOTES:

1. THE PRODUCT SHOWN HEREIN IS DESIGNED AND MANUFACTURED TO COMPLY WITH REQUIREMENTS OF THE 2018 IBC AND 2018 IRC.
2. WOOD FRAMING AND MASONRY OPENING TO BE DESIGNED AND ANCHORED TO PROPERLY TRANSFER ALL LOADS TO STRUCTURE. FRAMING AND MASONRY OPENING IS THE RESPONSIBILITY OF THE ARCHITECT OR ENGINEER OF RECORD.
3. ALLOWABLE STRESS INCREASE OF 1/3 WAS NOT USED IN THE DESIGN OF THE PRODUCT SHOWN HEREIN. WIND LOAD DURATION FACTOR Cd=1.6 WAS USED FOR WOOD ANCHOR CALCULATIONS.
4. BUCKS SHALL EXTEND BEYOND UNIT FRAME INTERIOR FACE SO THAT FULL FRAME SUPPORT IS PROVIDED.
5. FRAME MATERIAL: EXTRUDED RIGID PVC.
6. UNITS MUST BE GLAZED PER ASTM E1300, SEE SHEET 2 FOR GLASS DETAILS.
7. APPROVED IMPACT PROTECTIVE SYSTEM IS NOT REQUIRED FOR THIS PRODUCT IN WIND BORNE DEBRIS REGIONS.
8. SHIM AS REQUIRED AT EACH INSTALLATION ANCHOR WITH LOAD BEARING SHIM. SHIM WHERE SPACE OF 1/16" OR GREATER OCCURS. MAXIMUM ALLOWABLE SHIM STACK TO BE 1/4".
9. FOR ANCHORING INTO WOOD FRAMING OR 2X BUCK USE #10 WOOD SCREWS WITH SUFFICIENT LENGTH TO ACHIEVE A 1 1/4" MINIMUM EMBEDMENT INTO SUBSTRATE. LOCATE ANCHORS AS SHOWN IN ELEVATIONS AND INSTALLATION DETAILS.
10. FOR ANCHORING INTO MASONRY/CONCRETE USE 3/16" TAPCONS WITH SUFFICIENT LENGTH TO ACHIEVE A 1 1/4" MINIMUM EMBEDMENT INTO SUBSTRATE WITH 2" MINIMUM EDGE DISTANCE. LOCATE ANCHORS AS SHOWN IN ELEVATIONS AND INSTALLATION DETAILS.
11. FOR ANCHORING INTO METAL STRUCTURE USE #10 SMS OR SELF DRILLING SCREWS WITH SUFFICIENT LENGTH TO ACHIEVE 3 THREADS MINIMUM BEYOND STRUCTURE INTERIOR WALL. LOCATE ANCHORS AS SHOWN IN ELEVATIONS AND INSTALLATION DETAILS.
12. ALL FASTENERS TO BE CORROSION RESISTANT.
13. INSTALLATION ANCHORS SHALL BE INSTALLED IN ACCORDANCE WITH ANCHOR MANUFACTURER'S INSTALLATION INSTRUCTIONS AND ANCHORS SHALL NOT BE USED IN SUBSTRATES WITH STRENGTHS LESS THAN THE MINIMUM STRENGTH SPECIFIED BELOW:
 - A. WOOD – MINIMUM SPECIFIC GRAVITY OF G=0.42
 - B. CONCRETE – MINIMUM COMPRESSIVE STRENGTH OF 3,192 PSI.
 - C. MASONRY – STRENGTH CONFORMANCE TO ASTM C-90, GRADE N, TYPE 1 (OR GREATER).
 - D. METAL STRUCTURE: STEEL 18GA, 33KSI OR ALUMINUM 6063-T5 1/8" THICK MINIMUM
14. APPROVED CONFIGURATIONS: OX AND XO

SIGNED: 07/21/2022

TABLE OF CONTENTS	
SHEET NO.	DESCRIPTION
1	NOTES
2	ELEVATION AND GLAZING DETAIL
3 – 5	INSTALLATION DETAILS
6	COMPONENTS

REGENCY PLUS, INC. 2000 LOCUST GAP HIGHWAY MT. CARMEL, PA 17851		
SERIES 6412 VINYL HORIZONTAL SLIDING WINDOW 74" X 63" – IMPACT NOTES		
DRAWN: V.L.	DWG NO. 08-01715	REV C
SCALE NTS	DATE 09/17/12	SHEET 1 OF 6
L. ROBERTO LOMAS P.E. 400 S. PALM AVE, INDIALANTIC, FL 32903 434-688-0609 rllomas@rlomaspe.com		



Luis R. Lomas P.E.
 TX No.: 101889
 Firm No: F-23130

REVISIONS			
REV	DESCRIPTION	DATE	APPROVED
C	REVISED PER NEW REQUIREMENTS	07/21/2022	R.L.

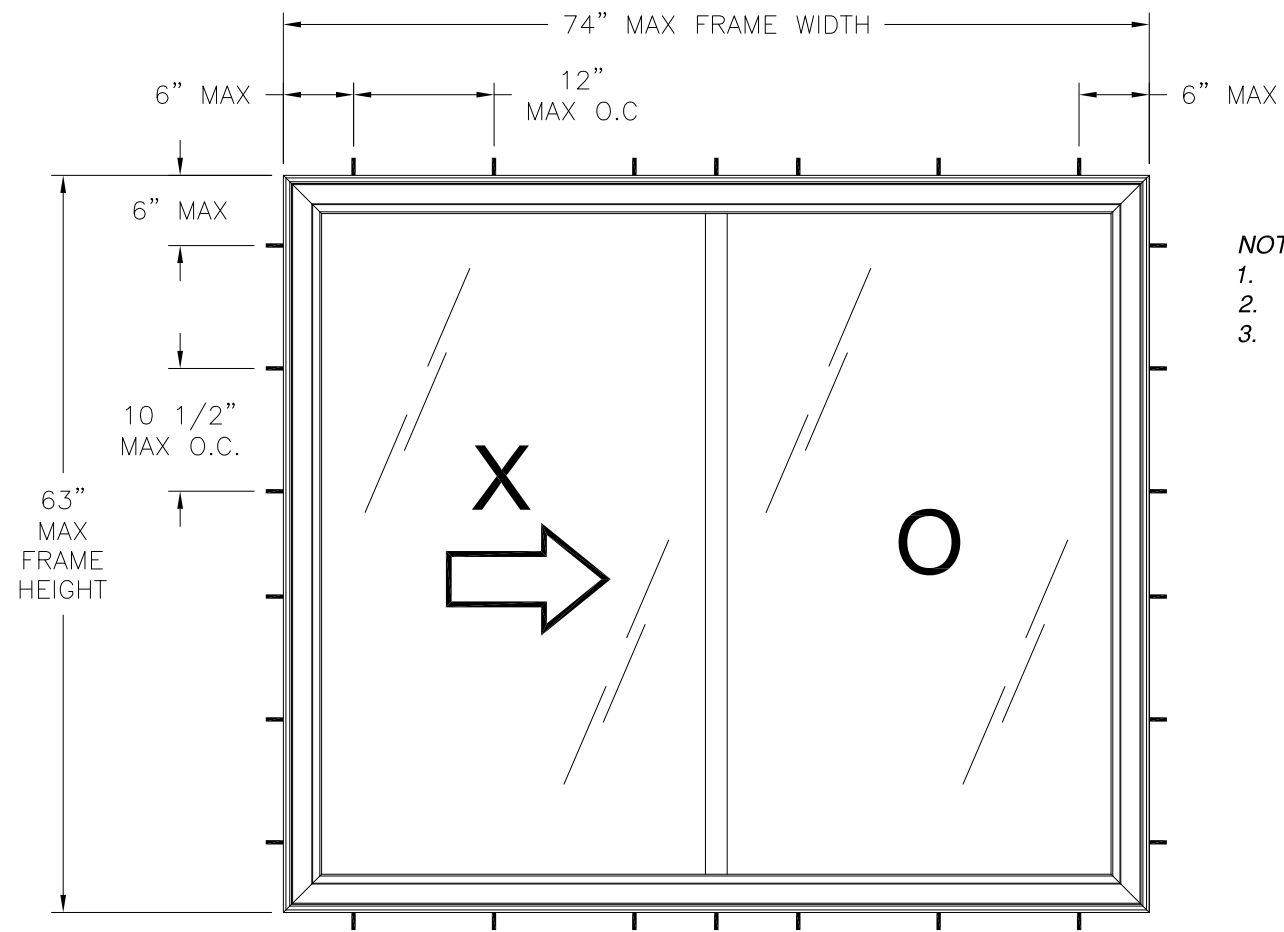

SERIES 6412 VINYL HORIZONTAL SLIDING WINDOW
EXTERIOR VIEW

DESIGN PRESSURE RATING	IMPACT RATING
+45.0/-50.0PSF	LARGE AND SMALL MISSILE IMPACT

MISSILE LEVEL D, WIND ZONE 4

NOTES:

1. MAXIMUM PANEL SIZE: 36 1/4" X 60"
2. MAXIMUM PANEL D.L.O.: 32 1/4" X 56 1/2"
3. MAXIMUM FIXED LITE D.L.O.: 33" X 57 1/2"

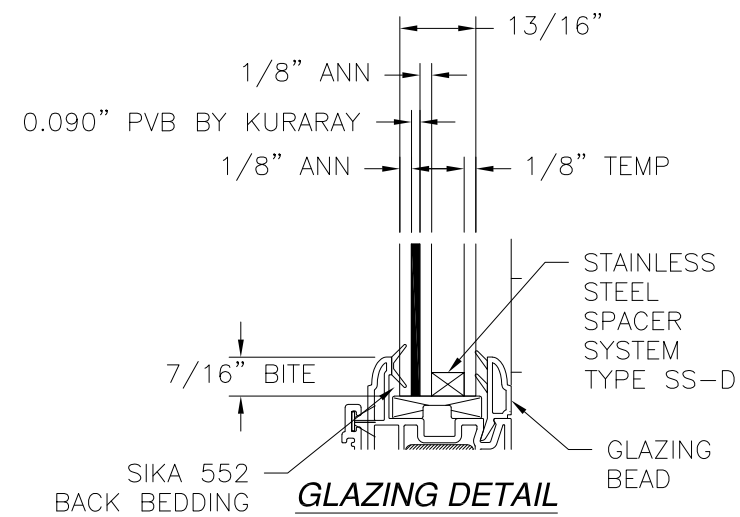

GLAZING DETAIL

SIGNED: 07/21/2022

REGENCY PLUS, INC.

2000 LOCUST GAP HIGHWAY
MT. CARMEL, PA 17851

SERIES 6412 VINYL HORIZONTAL SLIDING WINDOW
74" X 63" - IMPACT
ELEVATION AND GLAZING DETAIL

DRAWN: V.L.	DWG NO. 08-01715	REV C
SCALE NTS	DATE 09/17/12	SHEET 2 OF 6

L. ROBERTO LOMAS P.E.
400 S. PALM AVE, INDIALANTIC, FL 32903
434-688-0609 rllomas@rlomaspe.com



Luis R. Lomas P.E.
TX No.: 101889
Firm No: F-23130

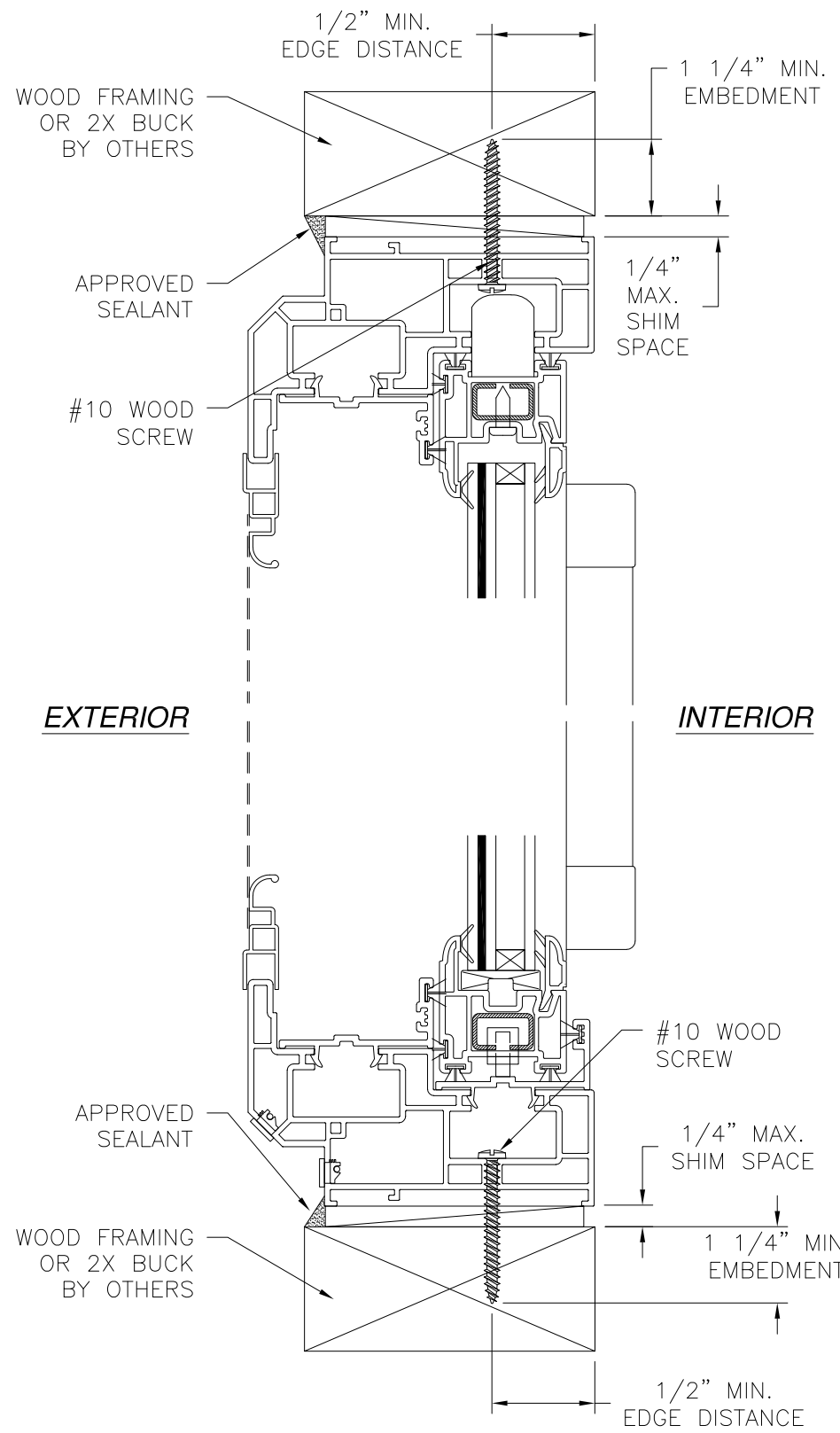

VERTICAL CROSS SECTION
WOOD FRAMING OR 2X BUCK INSTALLATION

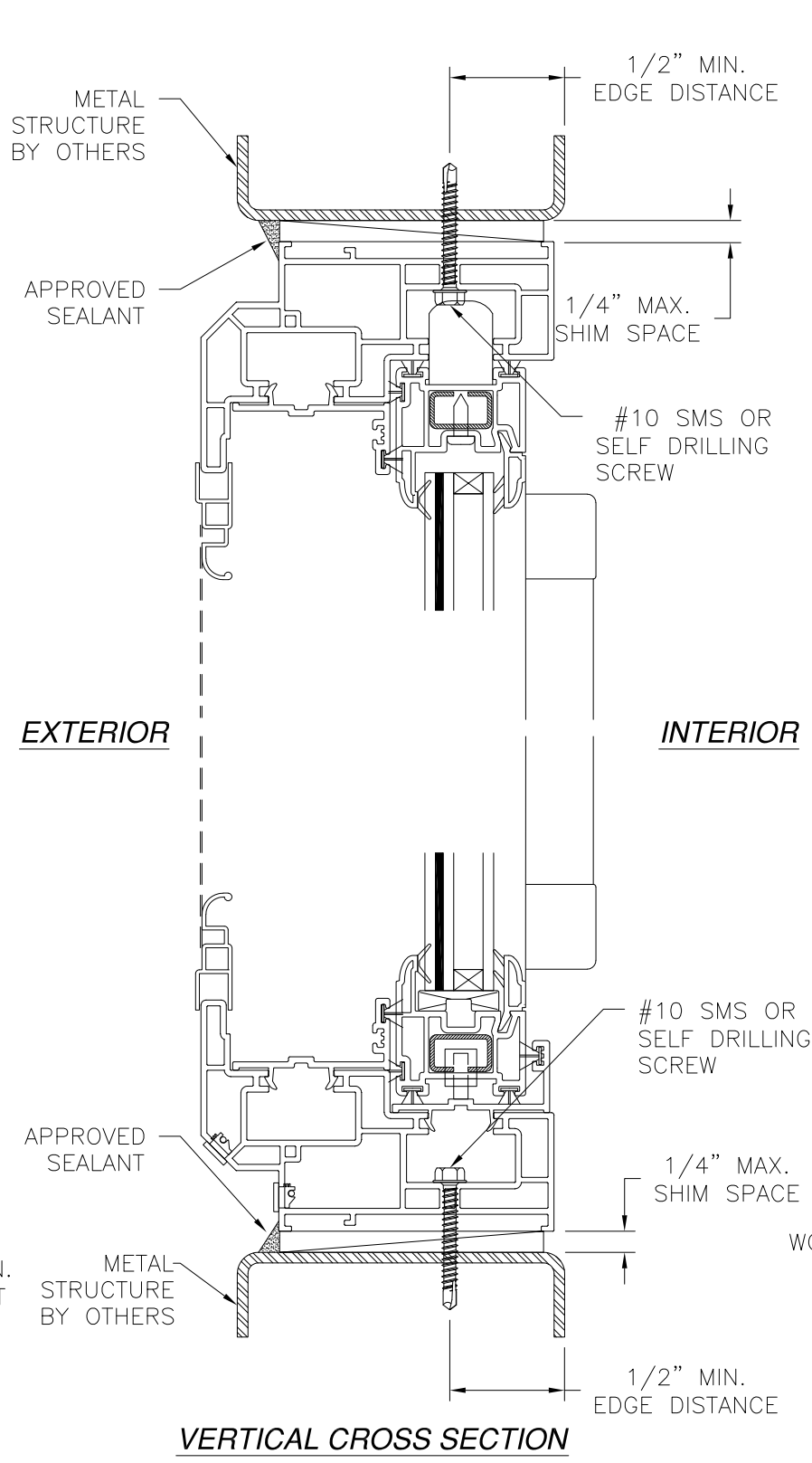

VERTICAL CROSS SECTION
METAL STRUCTURE INSTALLATION

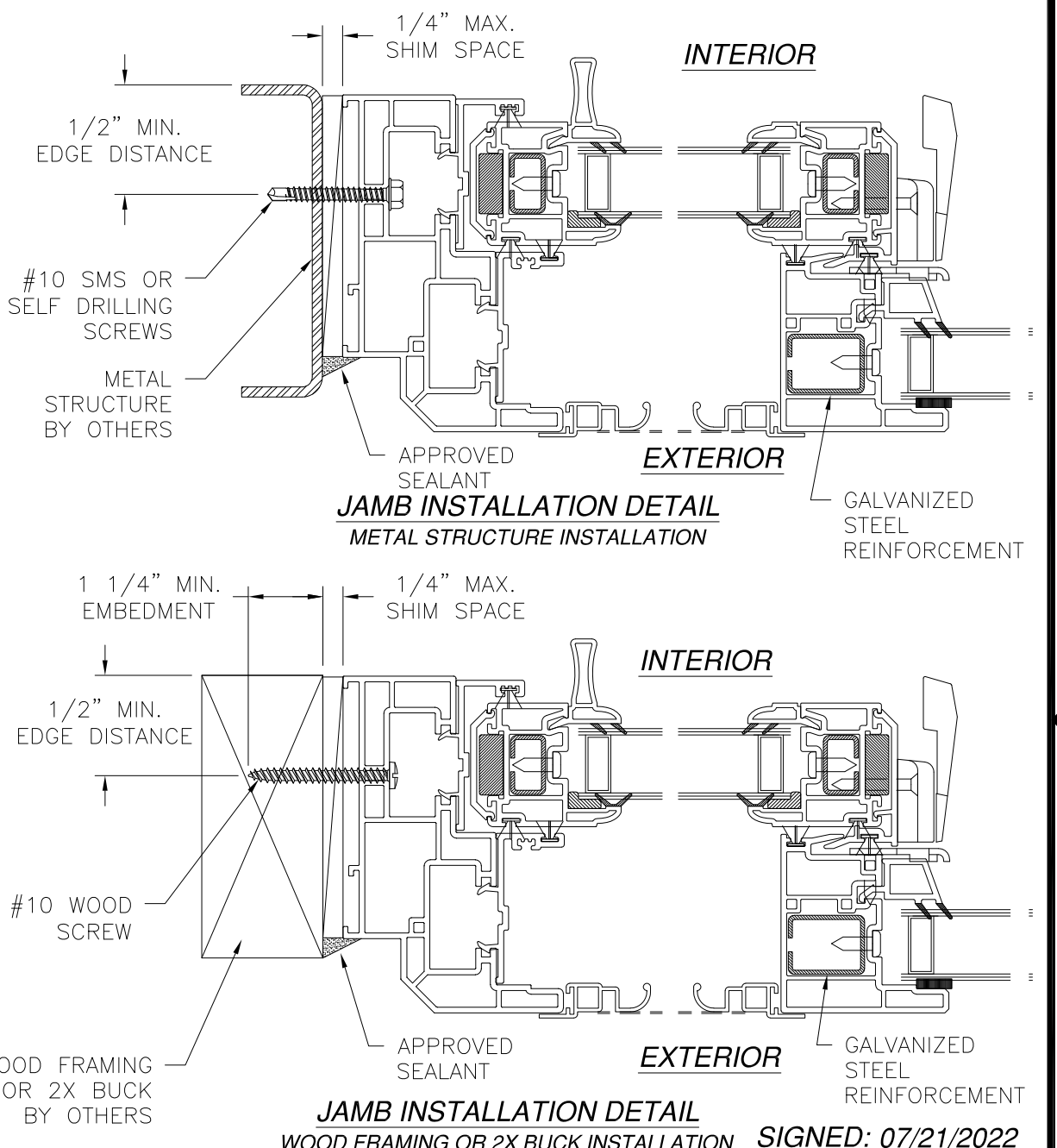

JAMB INSTALLATION DETAIL
WOOD FRAMING OR 2X BUCK INSTALLATION **SIGNED: 07/21/2022**

REVISIONS			
REV	DESCRIPTION	DATE	APPROVED
C	REVISED PER NEW REQUIREMENTS	07/21/2022	R.L.

- NOTES:**
1. INTERIOR AND EXTERIOR FINISHES, BY OTHERS, NOT SHOWN FOR CLARITY.
 2. PERIMETER AND JOINT SEALANT BY OTHERS TO BE DESIGNED IN ACCORDANCE WITH ASTM E2112

REGENCY PLUS, INC.
2000 LOCUST GAP HIGHWAY
MT. CARMEL, PA 17851

SERIES 6412 VINYL HORIZONTAL SLIDING WINDOW
74" X 63" - IMPACT
INSTALLATION DETAILS

DRAWN: V.L.	DWG NO. 08-01715	REV C
SCALE NTS	DATE 09/17/12	SHEET 3 OF 6

L. ROBERTO LOMAS P.E.
400 S. PALM AVE, INDIALANTIC, FL 32903
434-688-0609 rllomas@rlomaspe.com



Luis R. Lomas P.E.
TX No.: 101889
Firm No: F-23130

REVISIONS			
REV	DESCRIPTION	DATE	APPROVED
C	REVISED PER NEW REQUIREMENTS	07/21/2022	R.L.

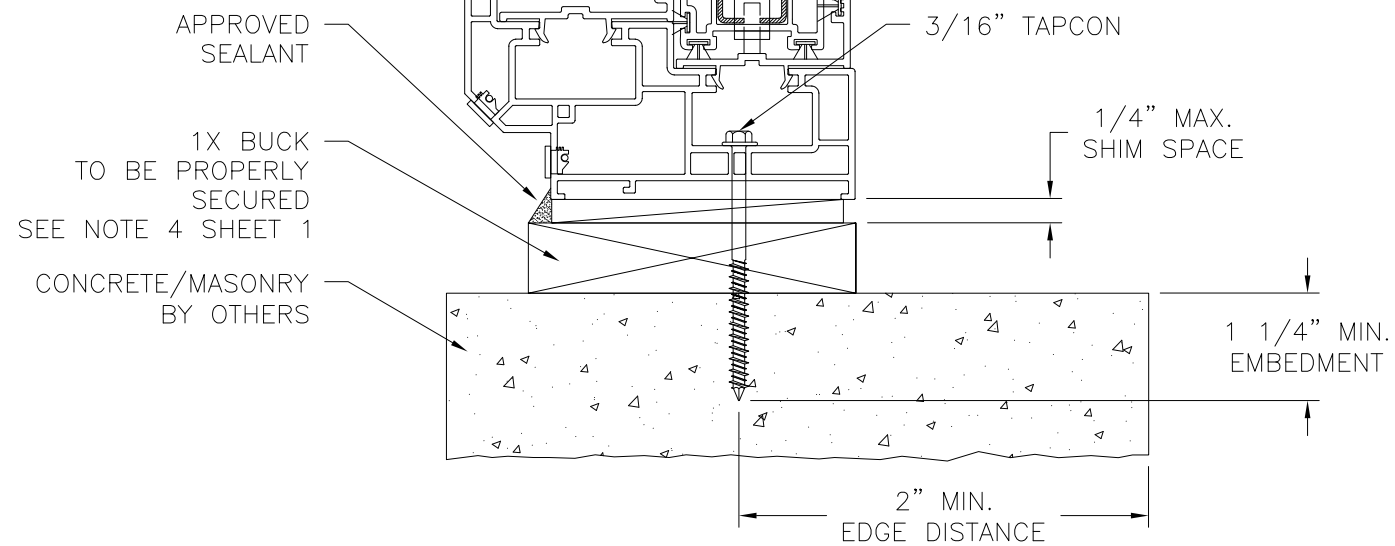
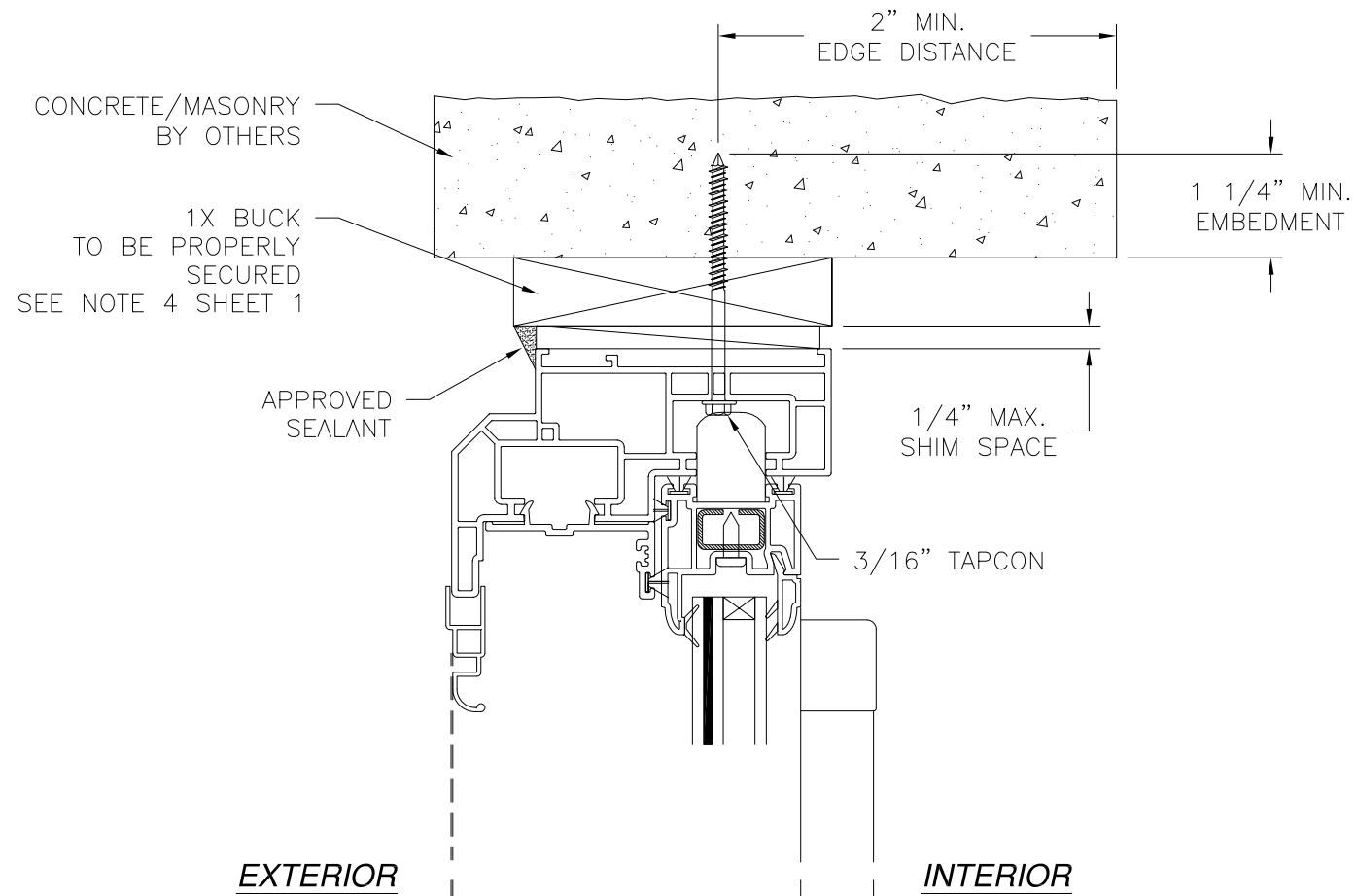

VERTICAL CROSS SECTION
CONCRETE/MASONRY W/1X BUCK INSTALLATION

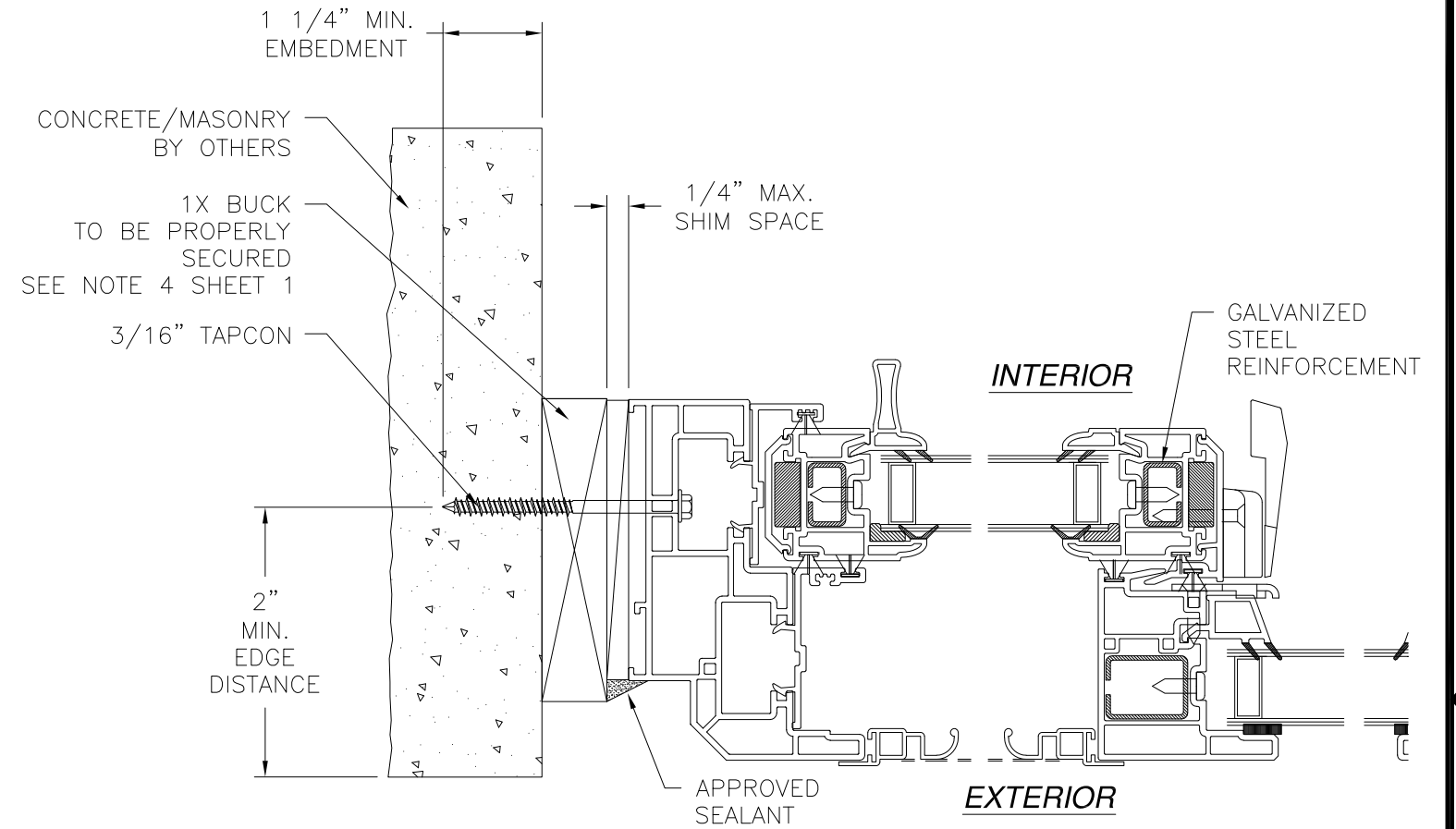

JAMB INSTALLATION DETAIL
CONCRETE/MASONRY W/1X BUCK INSTALLATION

NOTES:

1. INTERIOR AND EXTERIOR FINISHES, BY OTHERS, NOT SHOWN FOR CLARITY.
2. PERIMETER AND JOINT SEALANT BY OTHERS TO BE DESIGNED IN ACCORDANCE WITH ASTM E2112

SIGNED: 07/21/2022

REGENCY PLUS, INC.
2000 LOCUST GAP HIGHWAY
MT. CARMEL, PA 17851

SERIES 6412 VINYL HORIZONTAL SLIDING WINDOW
74" X 63" - IMPACT
INSTALLATION DETAILS

DRAWN: V.L.	DWG NO. 08-01715	REV C
SCALE NTS	DATE 09/17/12	SHEET 4 OF 6

L. ROBERTO LOMAS P.E.
400 S. PALM AVE, INDIAN LANTIC, FL 32903
434-688-0609 rllomas@rlomaspe.com



Luis R. Lomas P.E.
TX No.: 101889
Firm No: F-23130

REVISIONS			
REV	DESCRIPTION	DATE	APPROVED
C	REVISED PER NEW REQUIREMENTS	07/21/2022	R.L.

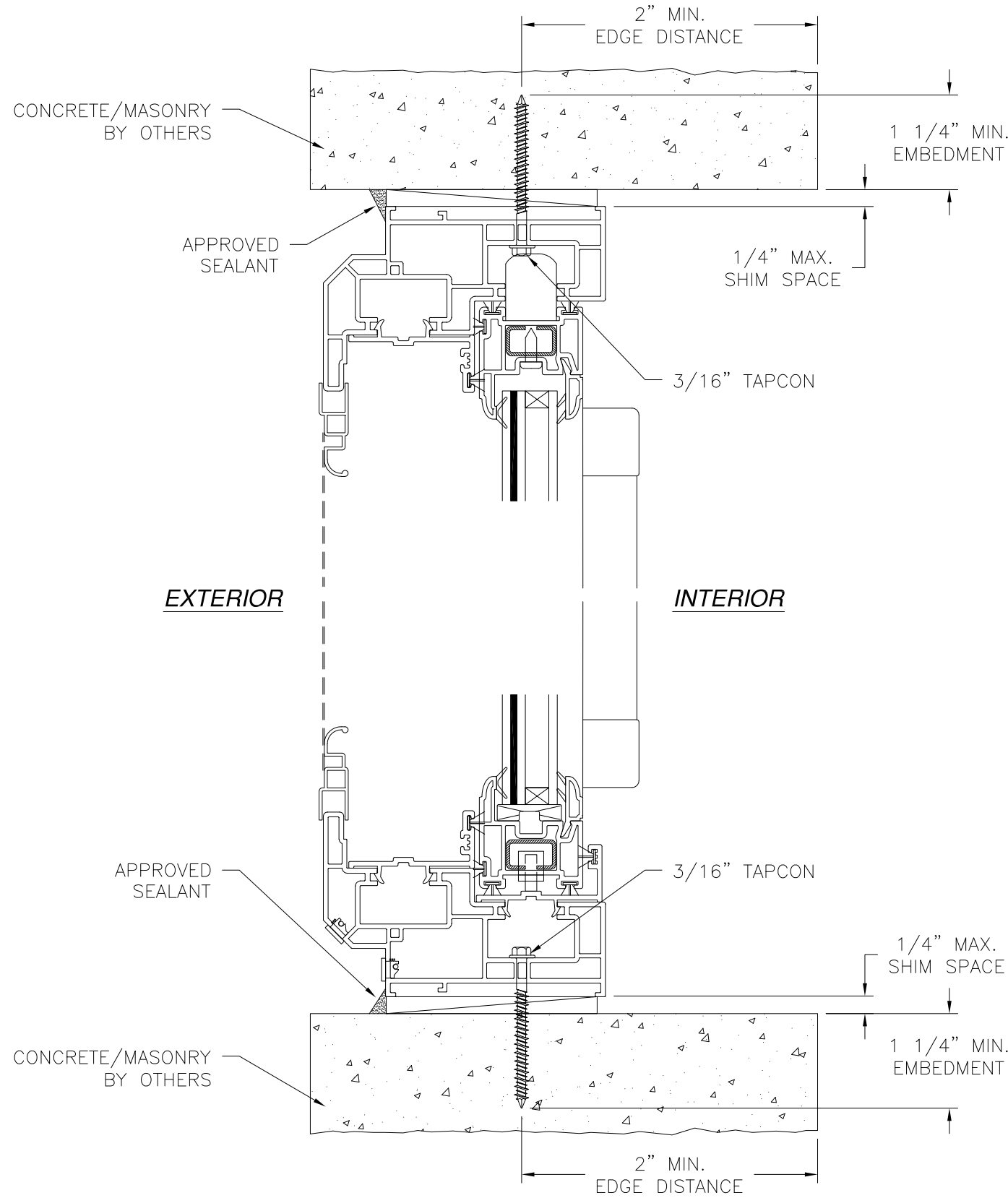

VERTICAL CROSS SECTION
CONCRETE/MASONRY INSTALLATION

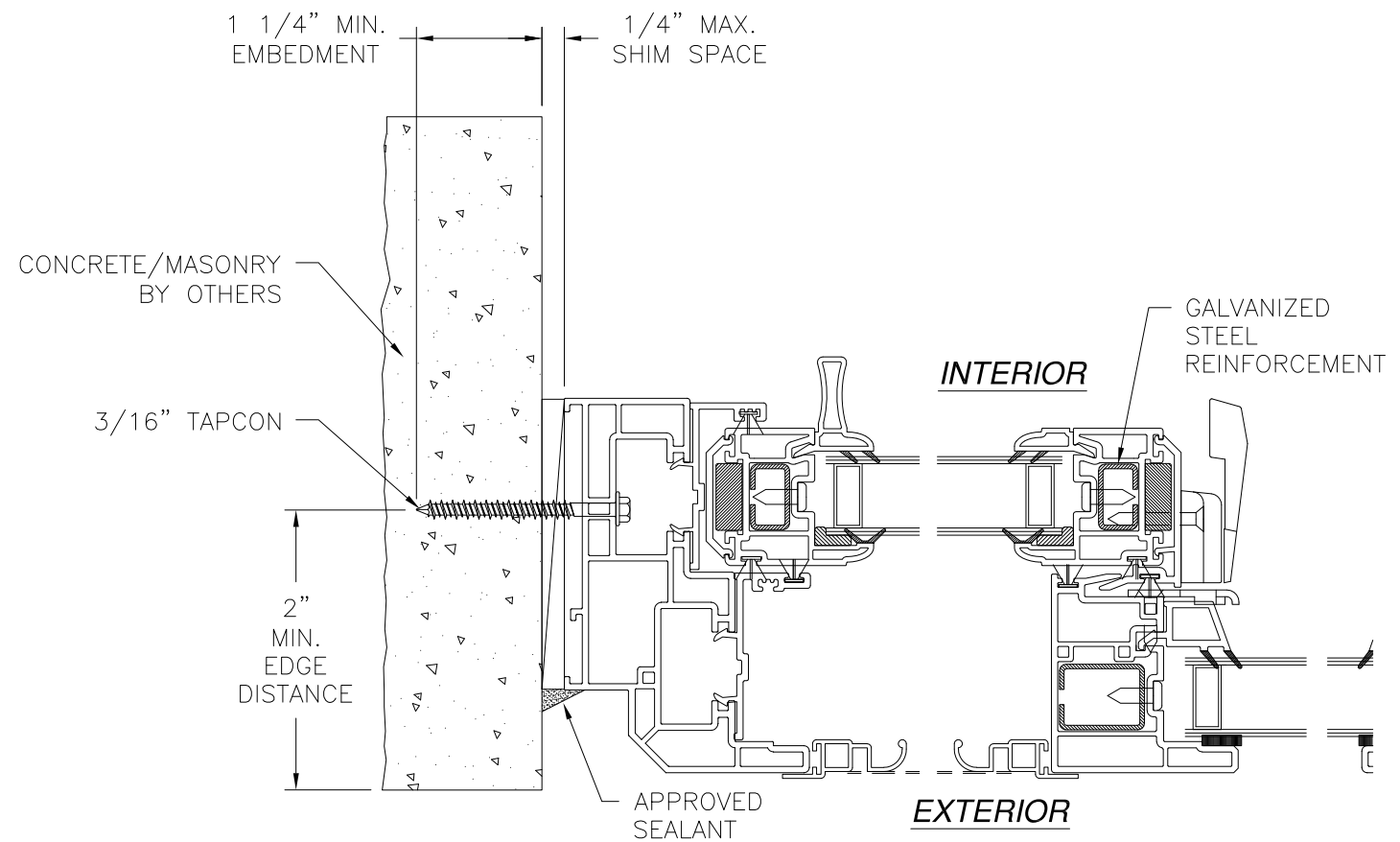

JAMB INSTALLATION DETAIL
CONCRETE/MASONRY INSTALLATION

- NOTES:**
1. INTERIOR AND EXTERIOR FINISHES, BY OTHERS, NOT SHOWN FOR CLARITY.
 2. PERIMETER AND JOINT SEALANT BY OTHERS TO BE DESIGNED IN ACCORDANCE WITH ASTM E2112

SIGNED: 07/21/2022

REGENCY PLUS, INC.
2000 LOCUST GAP HIGHWAY
MT. CARMEL, PA 17851

SERIES 6412 VINYL HORIZONTAL SLIDING WINDOW
74" X 63" - IMPACT
INSTALLATION DETAILS

DRAWN: V.L.	DWG NO. 08-01715	REV C
SCALE NTS	DATE 09/17/12	SHEET 5 OF 6

L. ROBERTO LOMAS P.E.
400 S. PALM AVE, INDIALANTIC, FL 32903
434-688-0609 rllomas@rlomaspe.com



Luis R. Lomas P.E.
TX No.: 101889
Firm No: F-23130

REVISIONS			
REV	DESCRIPTION	DATE	APPROVED
C	REVISED PER NEW REQUIREMENTS	07/21/2022	R.L.

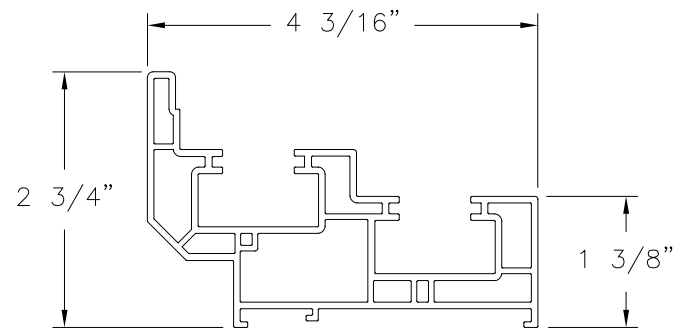

MAIN FRAME (1060)
RIGID PVC

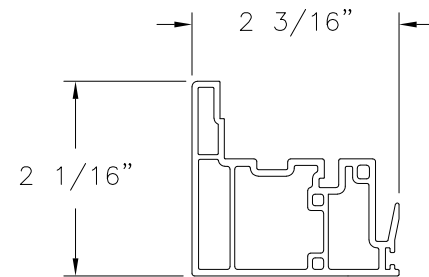

MULLION (1063)
RIGID PVC

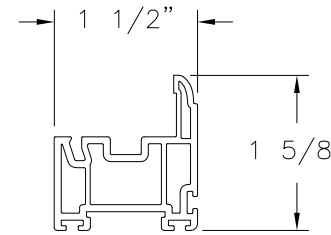

COMMON LOW PROFILE SASH (1282)
RIGID PVC

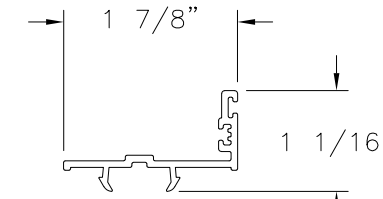

POCKET COVER (1776)
RIGID PVC

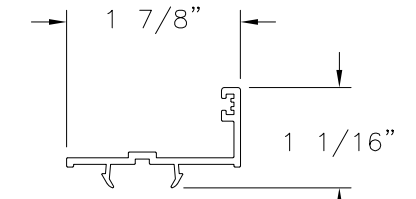

POCKET COVER (1073)
RIGID PVC

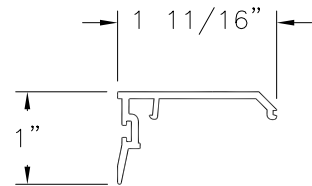

INTERLOCK COVER (1180)
RIGID PVC

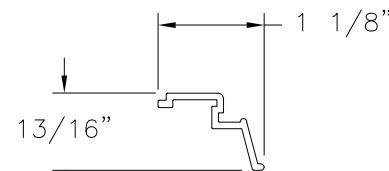

POCKET INSERT (1079)
RIGID PVC

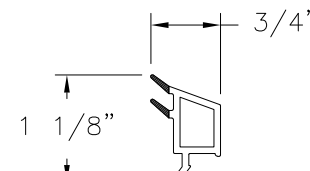

GLAZING STOP (1103)
RIGID PVC

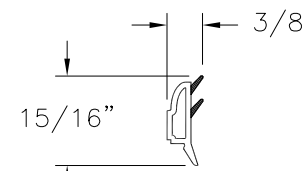

GLAZING STOP (X0035)
RIGID PVC

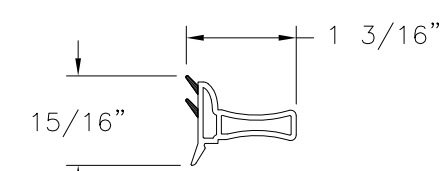

GLAZING STOP (X0033)
RIGID PVC

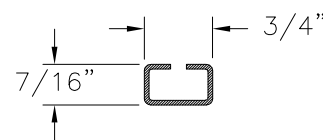

REINFORCEMENT (ST-226)
.060" GALVANIZED STEEL

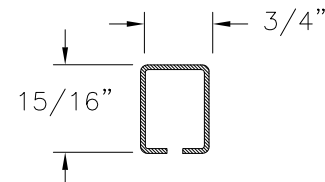

REINFORCEMENT (ST-888)
.050" GALVANIZED STEEL

REGENCY PLUS, INC.

2000 LOCUST GAP HIGHWAY
MT. CARMEL, PA 17851

SERIES 6412 VINYL HORIZONTAL SLIDING WINDOW
74" X 63" - IMPACT
COMPONENTS

DRAWN: V.L.	DWG NO. 08-01715	REV C
----------------	---------------------	----------

SCALE NTS	DATE 09/17/12	SHEET 6 OF 6
--------------	------------------	-----------------

L. ROBERTO LOMAS P.E.
400 S. PALM AVE, INDIALANTIC, FL 32903
434-688-0609 rllomas@rlomaspe.com

SIGNED: 07/21/2022



Luis R. Lomas P.E.
TX No.: 101889
Firm No: F-23130