

PW9020T THERMALLY-BROKEN, LARGE & SMALL MISSILE
IMPACT-RESISTANT PICTURE WINDOW

1. THE PRODUCT SHOWN HEREIN IS DESIGNED AND MANUFACTURED TO COMPLY WITH REQUIREMENTS OF THE 2018 INTERNATIONAL BUILDING CODE AND 2018 INTERNATIONAL RESIDENTIAL CODE.
2. WOOD FRAMING AND MASONRY OPENING TO BE DESIGNED AND ANCHORED TO PROPERLY TRANSFER ALL LOADS TO STRUCTURE. FRAMING AND MASONRY OPENING IS THE RESPONSIBILITY OF THE ARCHITECT OR ENGINEER OF RECORD.
3. 1X BUCK OVER MASONRY/CONCRETE IS OPTIONAL.
4. WHERE SHIM OR BUCK THICKNESS IS LESS THAN 1-1/2" WINDOW UNITS MUST BE ANCHORED THROUGH THE FRAME IN ACCORDANCE WITH MANUFACTURER'S PUBLISHED INSTALLATION INSTRUCTIONS. ANCHORS SHALL BE SECURELY FASTENED DIRECTLY INTO MASONRY, CONCRETE OR OTHER STRUCTURAL SUBSTRATE MATERIAL.
5. WHERE WOOD BUCK THICKNESS IS 1-1/2" OR GREATER, BUCK SHALL BE SECURELY FASTENED TO MASONRY, CONCRETE OR OTHER STRUCTURAL SUBSTRATE. WINDOW UNITS MAY BE ANCHORED THROUGH FRAME TO SECURED WOOD BUCK IN ACCORDANCE WITH MANUFACTURER'S PUBLISHED INSTALLATION INSTRUCTIONS.
6. WHERE 1X BUCK IS NOT USED DISSIMILAR MATERIALS MUST BE SEPARATED WITH APPROVED COATING OR MEMBRANE. SELECTION OF COATING OR MEMBRANE IS THE RESPONSIBILITY OF THE ARCHITECT OR ENGINEER OF RECORD.
7. BUCKS SHALL EXTEND BEYOND WINDOW INTERIOR FACE SO THAT FULL FRAME SUPPORT IS PROVIDED.
8. SHIM AS REQUIRED AT EACH INSTALLATION ANCHOR WITH LOAD BEARING SHIM. SHIM WHERE SPACE OF 1/16" OR GREATER OCCURS. MAXIMUM ALLOWABLE SHIM STACK TO BE 1/4".
9. SHIMS SHALL BE MADE FROM MATERIALS CAPABLE OF SUSTAINING APPLICABLE LOADS, LOCATED AND APPLIED IN A THICKNESS CAPABLE OF SUSTAINING APPLICABLE LOADS.
10. WIND LOAD DURATION FACTOR Cd=1.6 WAS USED FOR WOOD ANCHOR CALCULATIONS.
11. FRAME MATERIAL: ALUMINUM 6063-T6.
12. UNITS MUST BE GLAZED PER ASTM E1300, SEE SHEET 7 FOR GLASS DETAILS.
13. APPROVED IMPACT PROTECTIVE SYSTEM IS NOT REQUIRED FOR THIS PRODUCT IN WIND BORNE DEBRIS REGIONS.
14. LOCATE ANCHORS AS SHOWN IN ELEVATIONS AND INSTALLATION DETAILS.
15. ALL FASTENERS TO BE CORROSION RESISTANT.
16. INSTALLATION ANCHORS SHALL BE INSTALLED IN ACCORDANCE WITH ANCHOR MANUFACTURER'S INSTALLATION INSTRUCTIONS AND ANCHORS SHALL NOT BE USED IN SUBSTRATES WITH STRENGTHS LESS THAN THE MINIMUM STRENGTH SPECIFIED.
17. APPROVED GEOMETRIC SHAPES DIMENSIONS SHALL NOT EXCEED AN AREA OF 72 SQUARE FEET AS TESTED. GEOMETRIC SHAPES ARE NOT LIMITED TO SHAPES SHOWN HEREIN.
18. INSTALLATION ANCHORS MAY BE OF ANY HEAD TYPE.

TABLE 1:

Anchor	Substrate	Minimum Edge Distance	Minimum Embedment
#12 Steel or 410 SS Screw	Southern Pine (SG = .55)	5/8"	1-3/8"
	Aluminum, 6063-T5 min.	5/8"	0.06"
	Steel Stud, Gr. 33 min.	3/8"	0.045" (18 Ga.)
	A36 Steel	3/8"	0.05"
1/4" Steel Ultracon	Concrete (min. 3.0 ksi)	1"	1-3/8"
	UngROUTED CMU, (ASTM C-90)	1-1/2"	1-1/4"
	Southern Pine (SG = .55)	1"	1-3/8"
1/4" Steel Ultracon+	Concrete (min. 3.0 ksi)	1-1/8"	1-3/8"
	UngROUTED CMU, (ASTM C-90)	1-3/8"	1-1/4"
	Southern Pine (SG = .55)	1"	1-3/8"
1/4" Steel Creteflex	Concrete (min. 3.35 ksi)	1-3/4"	1"
	UngROUTED CMU, (ASTM C-90)	1-3/4"	1-1/4"
	Southern Pine (SG = .55)	1"	1-3/8"

1. ANCHOR MUST EXTEND A MINIMUM OF 3 THREADS BEYOND ANY METAL SUBSTRATE.
2. "UNGROUTED CMU" VALUES MAY BE USED FOR GROUTED CMU APPLICATIONS.
3. ALL ANCHOR HEAD TYPES ARE APPLICABLE.

TABLE 2:

Buck Width	Buck Height	Configuration	Glazing (see Sheet 7)	Rating / Design Pressure	Certification #
60	120	Single Lite, O	9/16" HS Lami	AW +/-100	167-504, 167-754
60	120	Single Lite, O	7/16" HS Lami IG	AW +/-90	167-505, 167-755
60	120	Double Lite, O/O	All	AW +100/-120	167-506, 167-756
96	72	Single Lite, O	All	AW +/-110	167-507, 167-757
144	72	Triple Lite, OOO	All	AW +/-85	167-514, 167-764

TABLE 3:

Sheet #	Description
1	General Notes
2	Single Window Elevations
3	Mulled Elevations
4	Flange Installation Details
5	Equal-Leg Installation Details
6	Fin Installation Details
7	Corner and Glazing Details
8	BOM and Extrusions

Revision:

Revision:

PREPARED BY A. LYNN MILLER 1070 TECHNOLOGY DRIVE N. VENICE, FL 34275 (941) 480-1600	COPYRIGHT © 2021 WINDOOR INC. LIMITED LICENSE TO MAKE COPIES FOR PERMITTING.	Date	02/10/21
		Drawn By	J ROSOWSKI
WINDOOR INCORPORATED WINDOOR INCORPORATED 104 TRIPLE DIAMOND BLVD. N VENICE, FL 34275; (833) 554-5432	THERMALLY-BROKEN PICTURE WINDOW (LM)	DWG No.	TDI-9020-LM-1
		Sheet	1 OF 8
GENERAL NOTES		Series	PW9020T

ANTHONY LYNN MILLER
 106954
 LICENSED PROFESSIONAL ENGINEER
 A. Lynn Miller 5/4/21
 A. LYNN MILLER, P.E.
 P.E.# 106954

ALL ARCHITECTURAL WINDOW SHAPES QUALIFIED,
COMMON EXAMPLES SHOWN. INSCRIBE THE SHAPE
IN A BLOCK AND OBTAIN DESIGN PRESSURES FOR
THAT BLOCK SIZE.

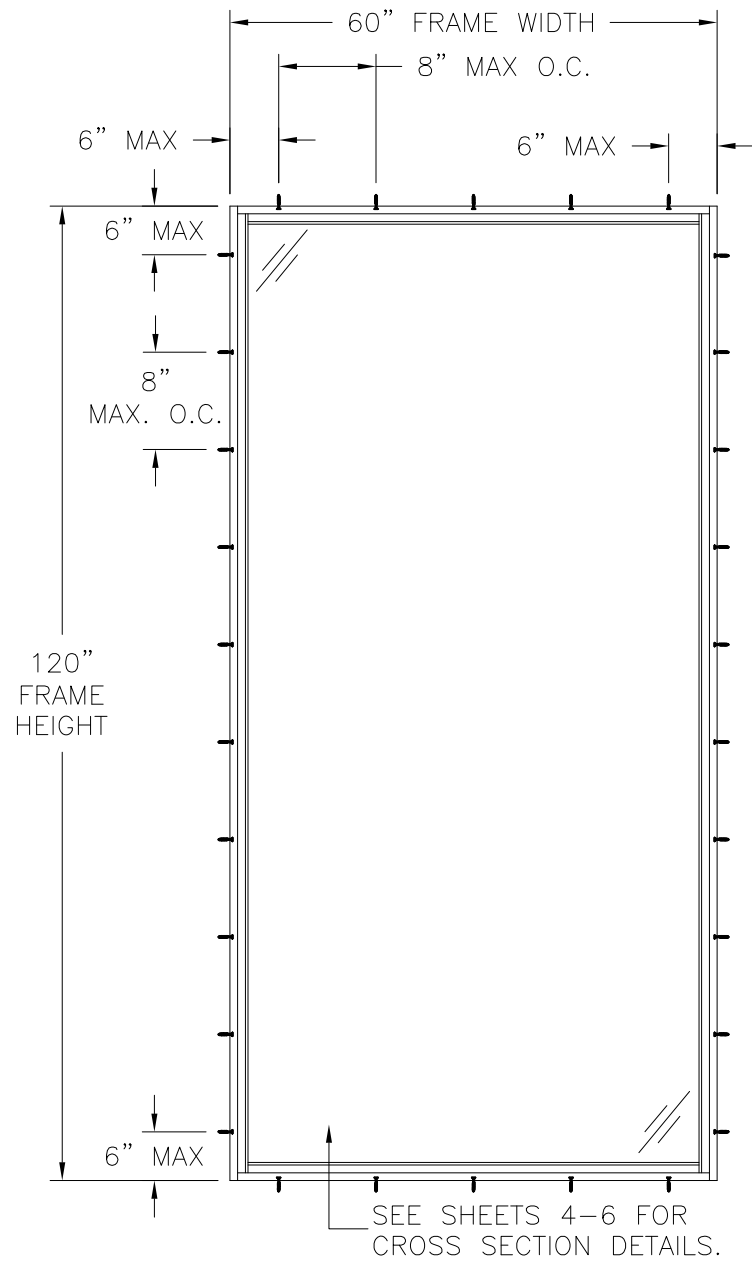
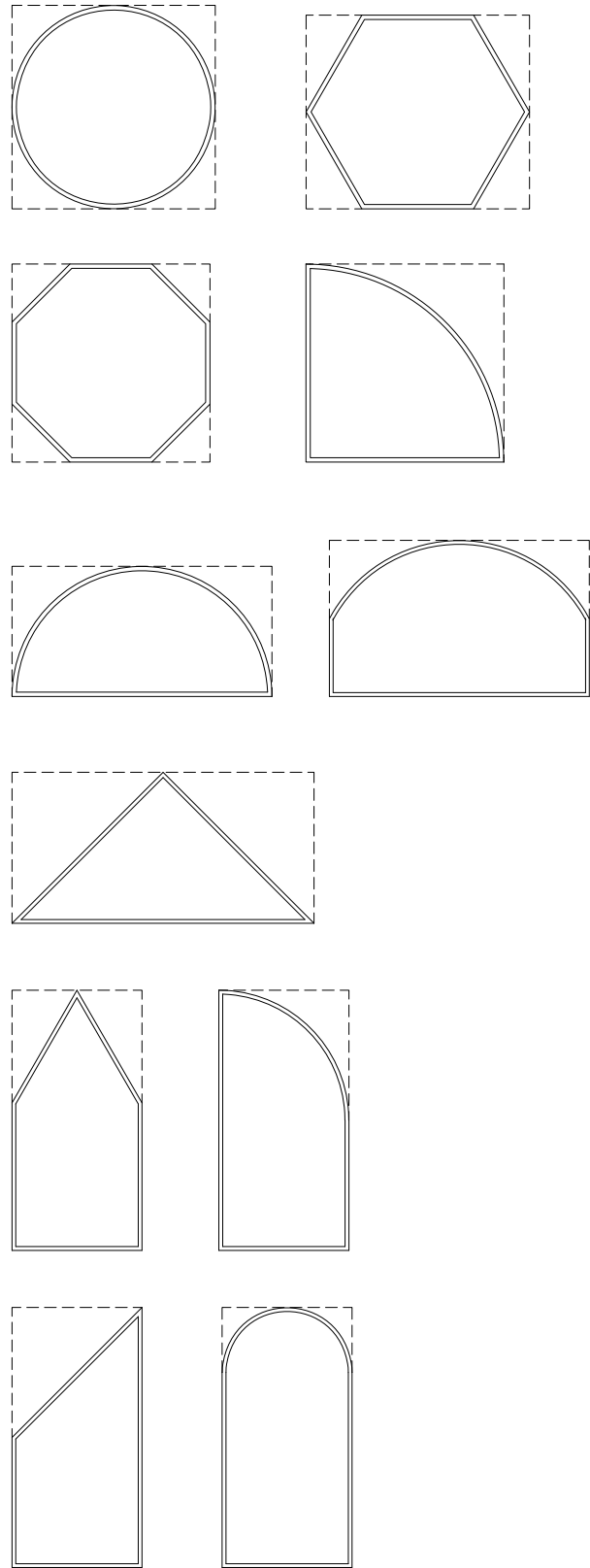

9020 PICTURE WINDOW

DESIGN PRESSURE RATING	IMPACT RATING
±100.0 PSF	LARGE & SMALL MISSILE IMPACT

MISSILE LEVEL D, WIND ZONE 4 AND HVHZ
WITH GLAZING A

DESIGN PRESSURE RATING	IMPACT RATING
±90.0 PSF	LARGE & SMALL MISSILE IMPACT

MISSILE LEVEL D, WIND ZONE 4 AND HVHZ
WITH GLAZING B

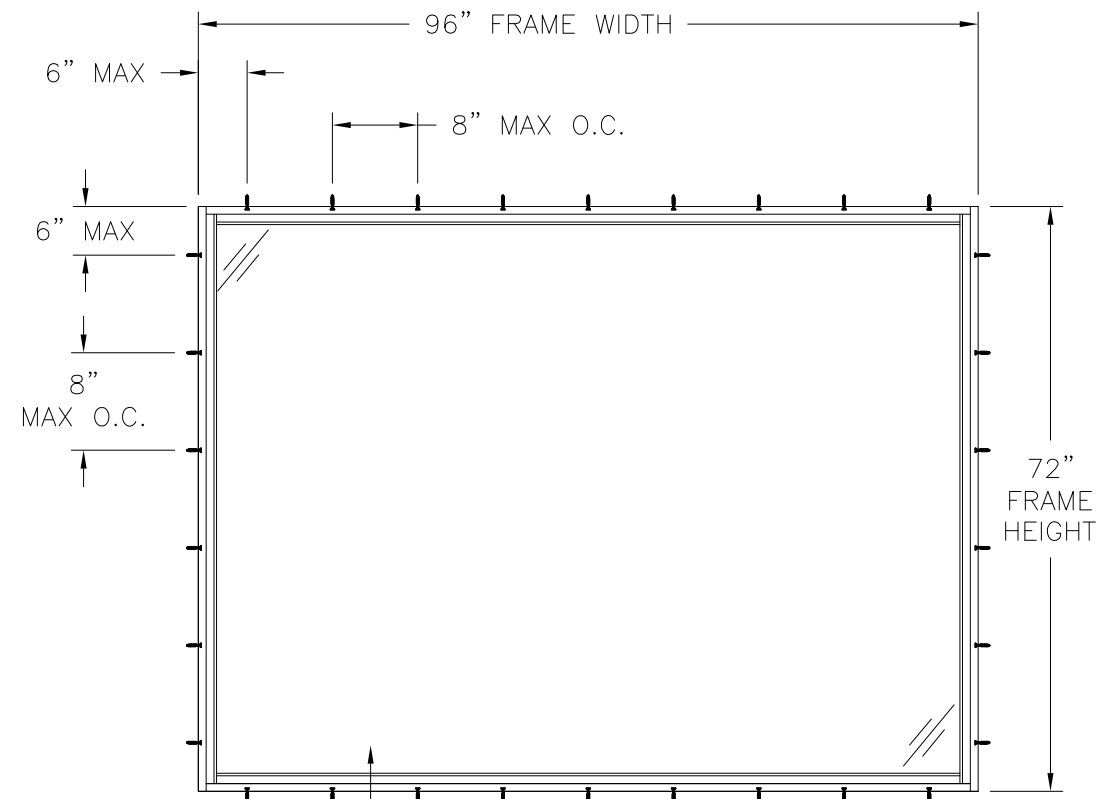

9020 PICTURE WINDOW

DESIGN PRESSURE RATING	IMPACT RATING
±110.0 PSF	LARGE & SMALL MISSILE IMPACT

MISSILE LEVEL D, WIND ZONE 4 AND HVHZ
WITH GLAZING A & B

NOTES:

1. CONFIGURATIONS SHOWN MAY BE ROTATED 90°.
2. WINDOW ENVELOPE SIZE MAY NOT BE EXCEEDED.

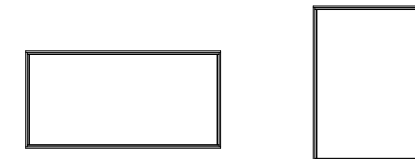

Revision:

PREPARED BY A. LYNN MILLER 1070 TECHNOLOGY DRIVE N. VENICE, FL 34275 (941) 480-1600	COPYRIGHT © 2021 WINDOOR INC. LIMITED LICENSE TO MAKE COPIES FOR PERMITTING.	Date	02/10/21
		Drawn By	J ROSOWSKI
WINDOOR® INCORPORATED WINDOOR INCORPORATED 104 TRIPLE DIAMOND BLVD. N VENICE, FL 34275; (833) 554-5432	THERMALLY-BROKEN PICTURE WINDOW (LM)	DWG No.	TDI-9020-LM-1
		Series	PW9020T
SINGLE WINDOW ELEVATIONS		Sheet	2 OF 8

A. Lynn Miller 5/4/21
A. LYNN MILLER, P.E.
P.E.# 106954

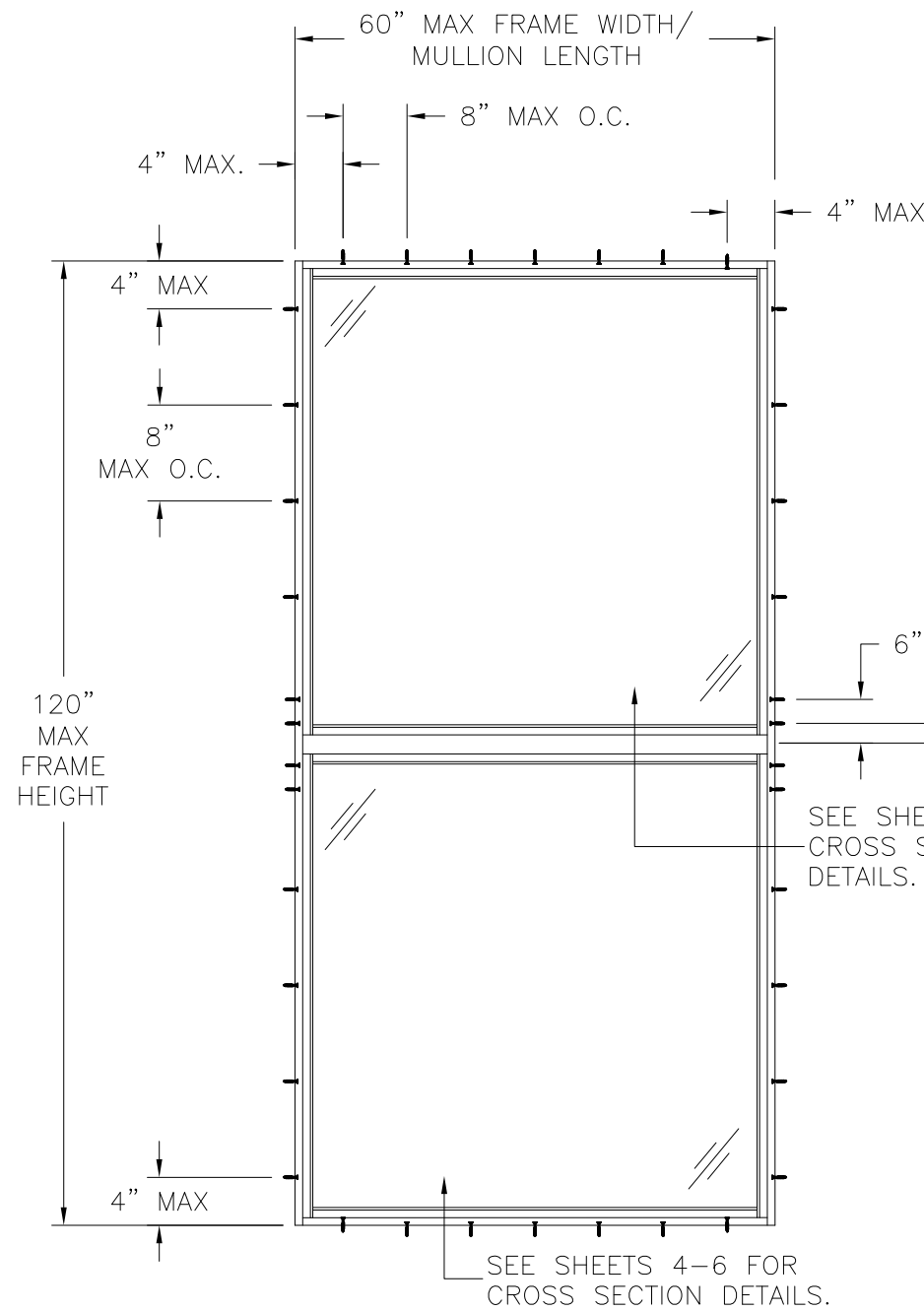

9020 PICTURE WINDOW

DESIGN PRESSURE RATING	IMPACT RATING
+100.0/-120.0 PSF	LARGE & SMALL MISSILE IMPACT

MISSILE LEVEL D, WIND ZONE 4 AND HVHZ WITH GLAZING A & B

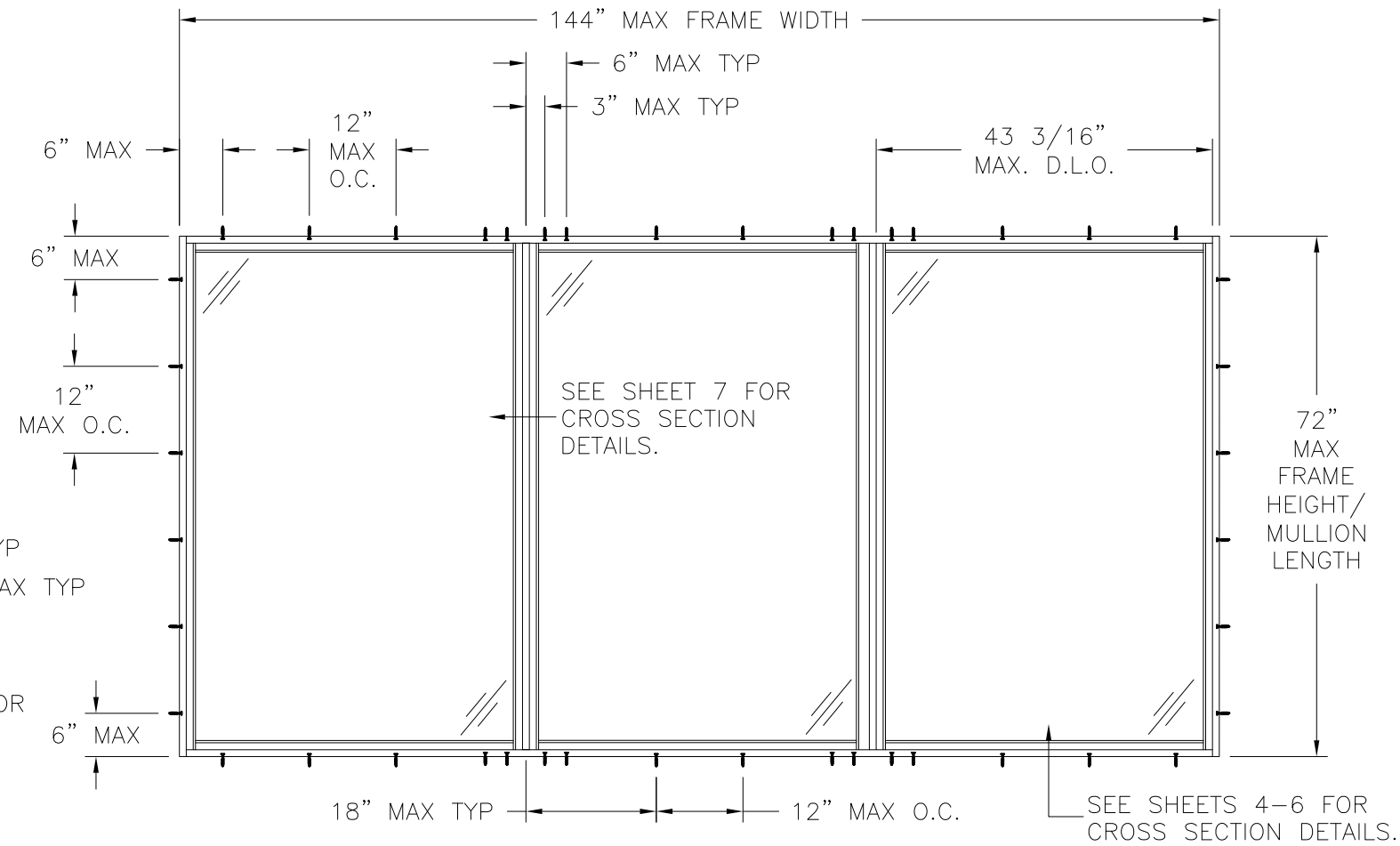

9020 TRIPLE PICTURE WINDOW

DESIGN PRESSURE RATING	IMPACT RATING
±85.0 PSF	LARGE & SMALL MISSILE IMPACT

MISSILE LEVEL D, WIND ZONE 4 AND HVHZ WITH GLAZING A & B

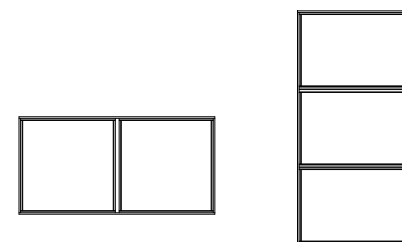

- NOTES:**
 1. CONFIGURATIONS SHOWN MAY BE ROTATED 90°.
 2. WINDOW ENVELOPE SIZE MAY NOT BE EXCEEDED.

Revision:

--	--

PREPARED BY A. LYNN MILLER 1070 TECHNOLOGY DRIVE N. VENICE, FL 34275 (941) 480-1600	COPYRIGHT © 2021 WINDOOR INC. LIMITED LICENSE TO MAKE COPIES FOR PERMITTING.	Date	02/10/21
		Drawn By	J ROSOWSKI
WINDOOR® INCORPORATED WINDOOR INCORPORATED 104 TRIPLE DIAMOND BLVD. N VENICE, FL 34275; (833) 554-5432	THERMALLY-BROKEN PICTURE WINDOW (LM)	DWG No.	TDI-9020-LM-1
		Sheet	3 OF 8
MULLED WINDOWS ELEVATION		Series	PW9020T

ANTHONY LYNN MILLER
 106954
 LICENSED PROFESSIONAL ENGINEER
 A. Lynn Miller 5/4/21
 A. LYNN MILLER, P.E.
 P.E.# 106954

FLANGE INSTALLATION

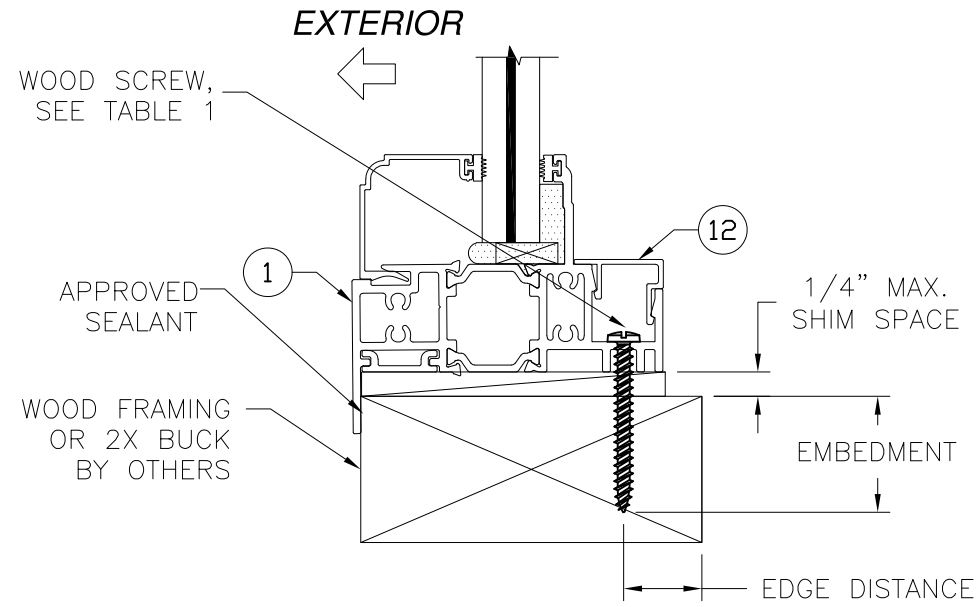

VERTICAL CROSS SECTION
WOOD FRAMING OR 2X BUCK INSTALLATION

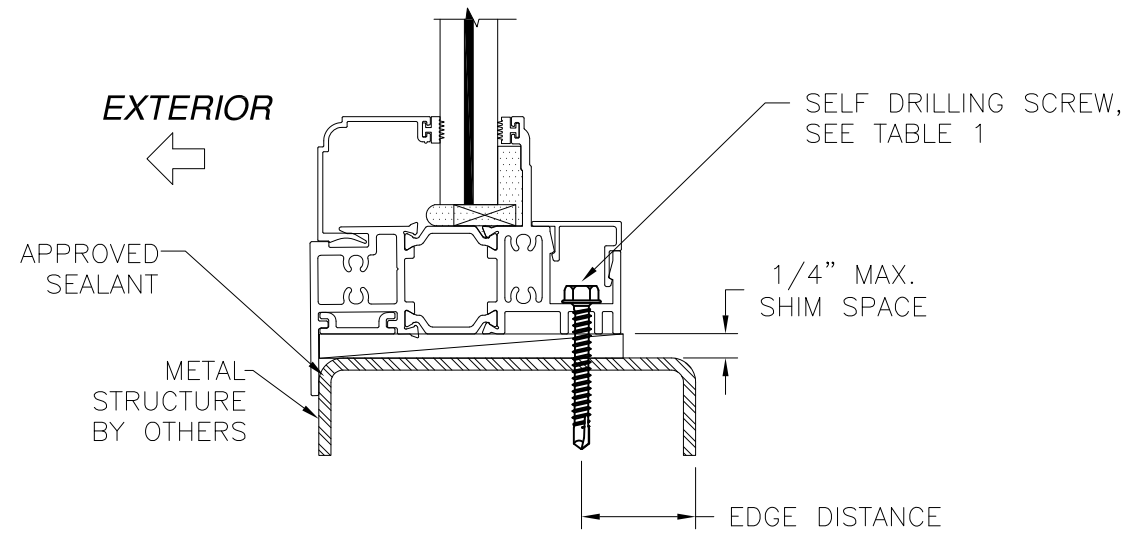

VERTICAL CROSS SECTION
METAL STRUCTURE INSTALLATION

DETAILS SHOWN FOR THE SILL BUT ALSO APPLY TO THE HEAD AND JAMBS.

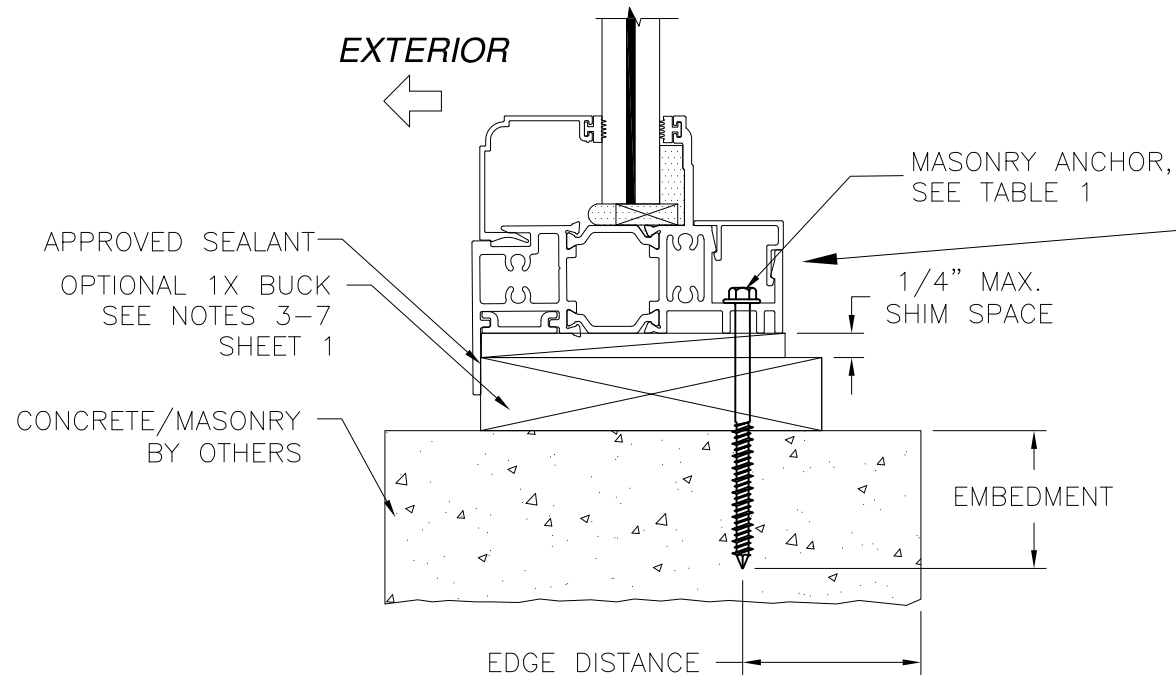

VERTICAL CROSS SECTION
CONCRETE/MASONRY INSTALLATION

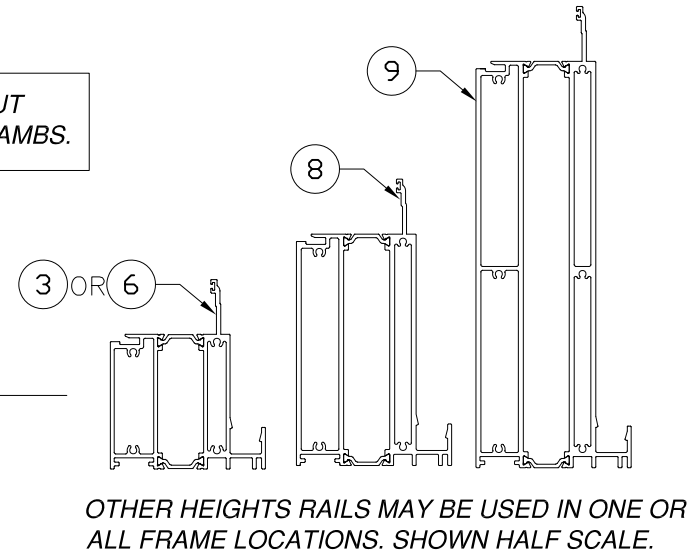

- NOTES:**
1. INTERIOR AND EXTERIOR FINISHES, BY OTHERS, NOT SHOWN FOR CLARITY.
 2. PERIMETER AND JOINT SEALANT BY OTHERS TO BE DESIGNED IN ACCORDANCE WITH ASTM E2112

Revision:

PREPARED BY A. LYNN MILLER 1070 TECHNOLOGY DRIVE N. VENICE, FL 34275 (941) 480-1600	COPYRIGHT © 2021 WINDOOR INC. LIMITED LICENSE TO MAKE COPIES FOR PERMITTING.	Date	02/10/21
		By	J ROSOWSKI
WINDOOR® INCORPORATED WINDOOR INCORPORATED 104 TRIPLE DIAMOND BLVD. N VENICE, FL 34275; (833) 554-5432	THERMALLY-BROKEN PICTURE WINDOW (LM)	DWG No.	TDI-9020-LM-1
		Sheet	4 OF 8
FLANGE INSTALLATION		Series	PW9020T

A. Lynn Miller 5/4/21
 A. LYNN MILLER, P.E.
 P.E.# 106954

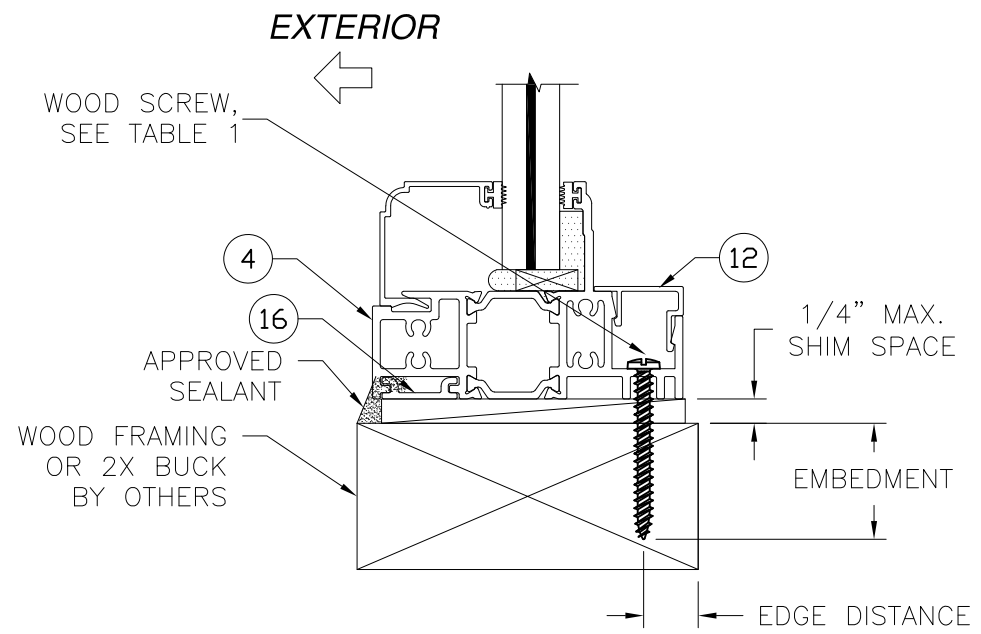

VERTICAL CROSS SECTION
WOOD FRAMING OR 2X BUCK INSTALLATION

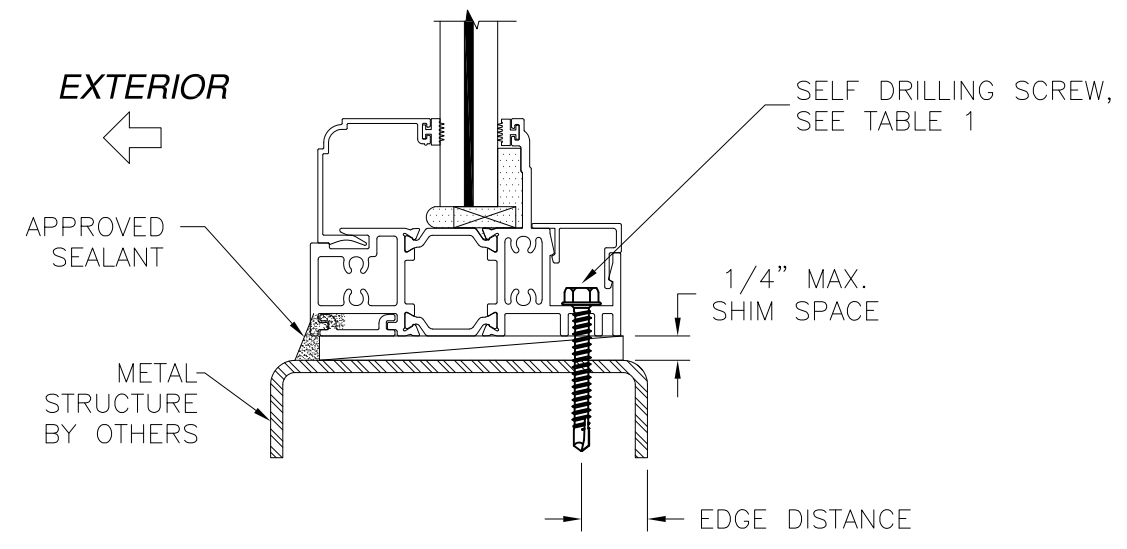

VERTICAL CROSS SECTION
METAL STRUCTURE INSTALLATION

DETAILS SHOWN FOR THE SILL BUT ALSO APPLY TO THE HEAD AND JAMBS.

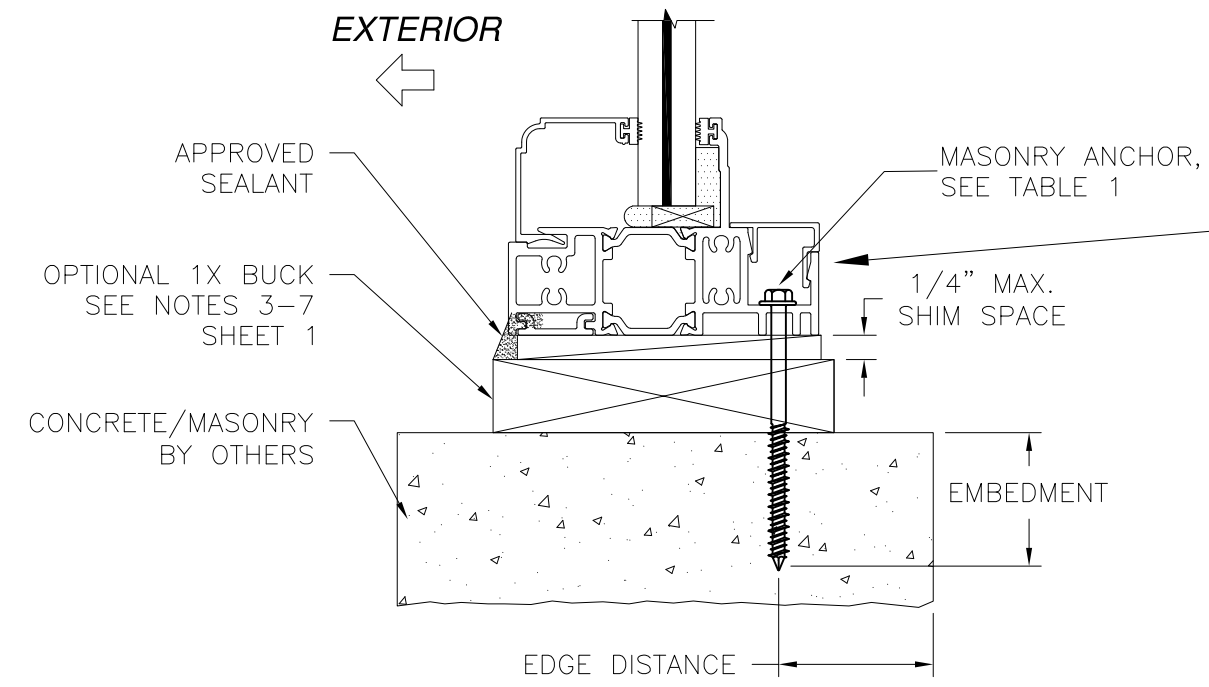

VERTICAL CROSS SECTION
CONCRETE/MASONRY INSTALLATION

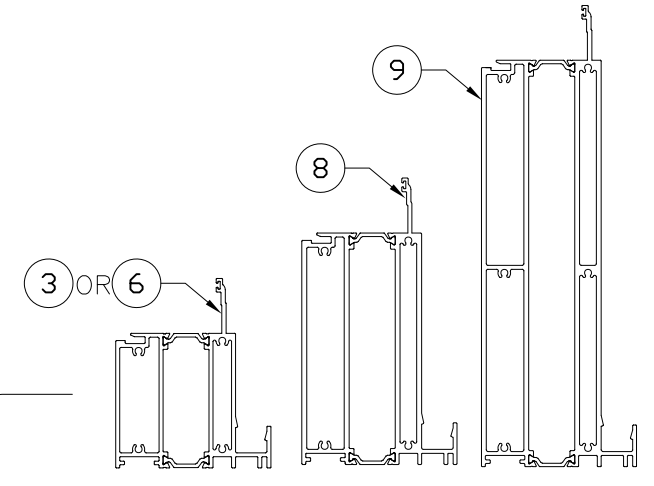

OTHER HEIGHTS RAILS MAY BE USED IN ONE OR ALL FRAME LOCATIONS. SHOWN HALF SCALE.

- NOTES:**
1. INTERIOR AND EXTERIOR FINISHES, BY OTHERS, NOT SHOWN FOR CLARITY.
 2. PERIMETER AND JOINT SEALANT BY OTHERS TO BE DESIGNED IN ACCORDANCE WITH ASTM E2112

Revision:

--	--

PREPARED BY A. LYNN MILLER 1070 TECHNOLOGY DRIVE N. VENICE, FL 34275 (941) 480-1600	COPYRIGHT © 2021 WINDOOR INC. LIMITED LICENSE TO MAKE COPIES FOR PERMITTING.	Date	02/10/21
		Drawn By	J ROSOWSKI
WINDOOR® INCORPORATED WINDOOR INCORPORATED 104 TRIPLE DIAMOND BLVD. N VENICE, FL 34275; (833) 554-5432	THERMALLY-BROKEN PICTURE WINDOW (LM) EQUAL-LEG INSTALLATION	DWG No.	TDI-9020-LM-1
		Sheet	5 OF 8
Series	PW9020T	Desc.	

A. Lynn Miller 5/4/21
A. LYNN MILLER, P.E.
P.E.# 106954

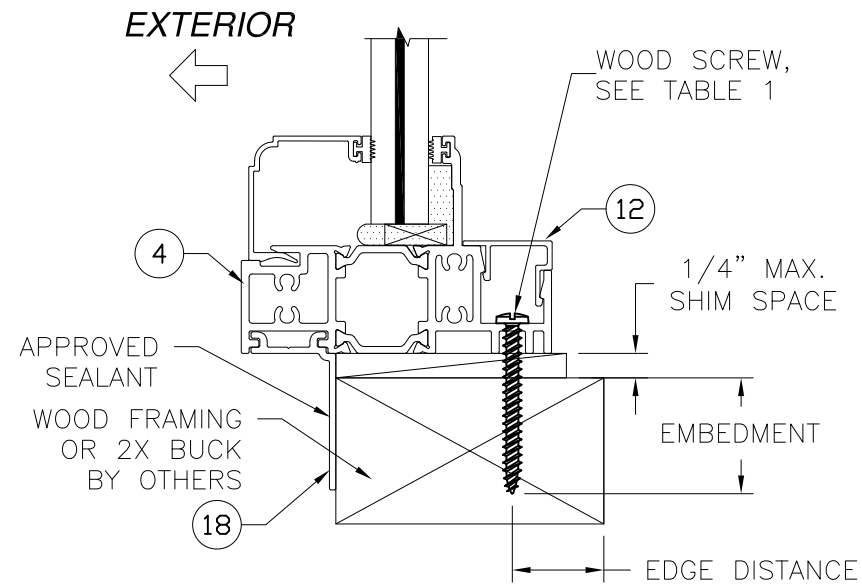

ADD-ON-FIN
WOOD FRAMING OR 2X BUCK INSTALLATION

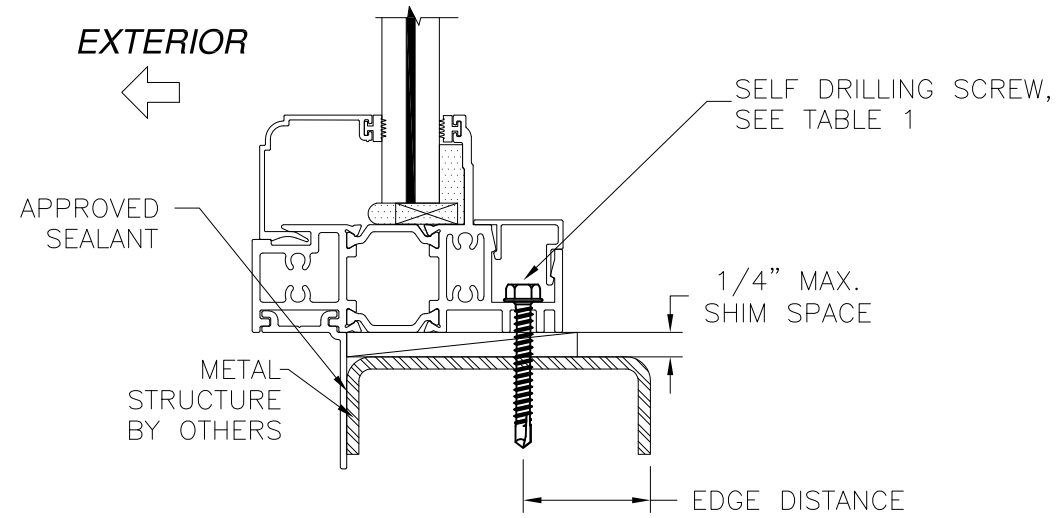

ADD-ON-FIN
METAL STRUCTURE INSTALLATION

DETAILS SHOWN FOR THE SILL BUT ALSO APPLY TO THE HEAD AND JAMBS.

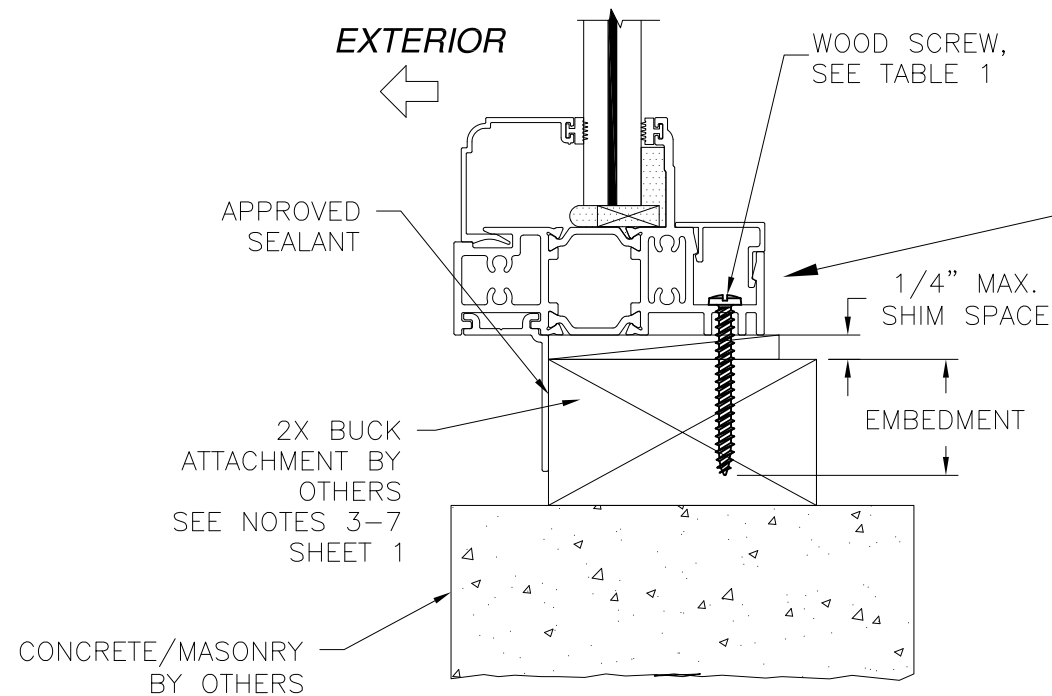

ADD-ON-FIN
CONCRETE/MASONRY INSTALLATION
SILL SHOWN, HEAD AND JAMB SIMILAR

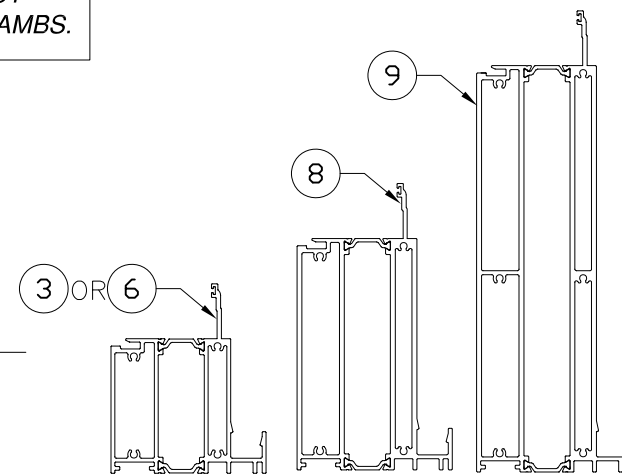

OTHER HEIGHTS RAILS MAY BE USED IN ONE OR ALL FRAME LOCATIONS. SHOWN HALF SCALE.

- NOTES:**
1. INTERIOR AND EXTERIOR FINISHES, BY OTHERS, NOT SHOWN FOR CLARITY.
 2. PERIMETER AND JOINT SEALANT BY OTHERS TO BE DESIGNED IN ACCORDANCE WITH ASTM E2112

Revision:

PREPARED BY A. LYNN MILLER 1070 TECHNOLOGY DRIVE N. VENICE, FL 34275 (941) 480-1600	COPYRIGHT © 2021 WINDOOR INC. LIMITED LICENSE TO MAKE COPIES FOR PERMITTING.	Date	02/10/21
		By	J ROSOWSKI
WINDOOR® INCORPORATED WINDOOR INCORPORATED 104 TRIPLE DIAMOND BLVD. N VENICE, FL 34275; (833) 554-5432	THERMALLY-BROKEN PICTURE WINDOW (LM)	DWG No.	TDI-9020-LM-1
		Sheet	6 OF 8
Series	PW9020T	Desc.	FIN INSTALLATION

A. Lynn Miller 5/4/21
 A. LYNN MILLER, P.E.
 P.E.# 106954

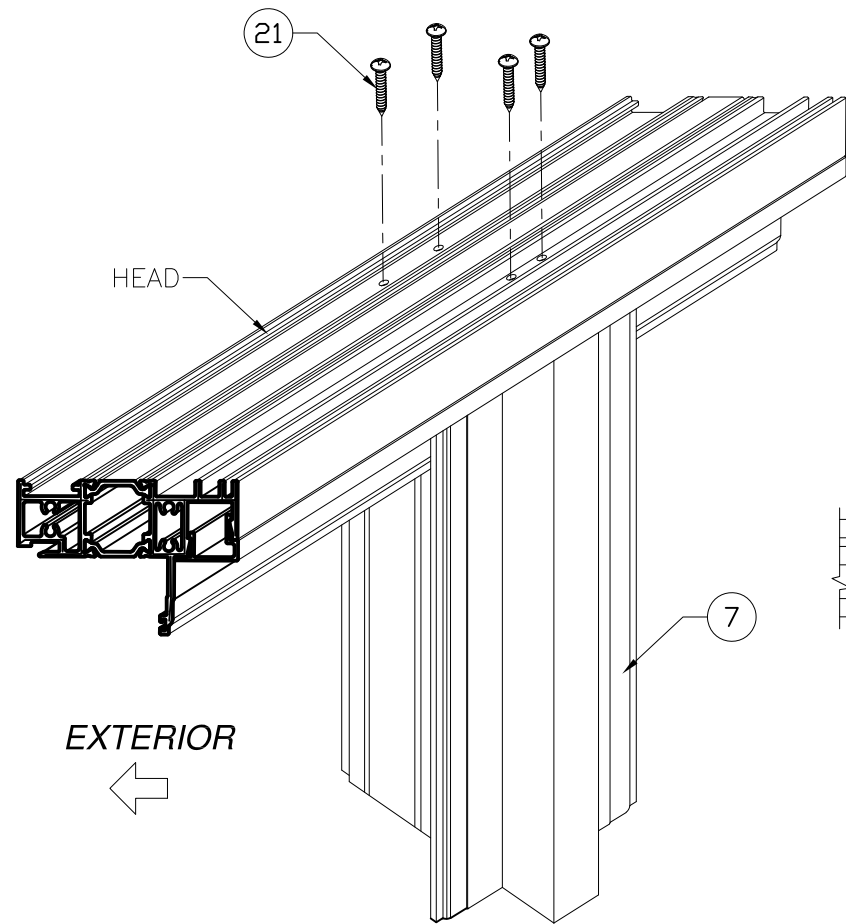

EXTERIOR

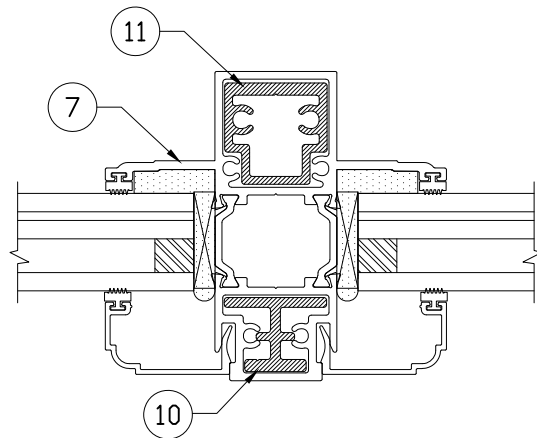

VERTICAL CROSS SECTION
INTEGRAL MULLION

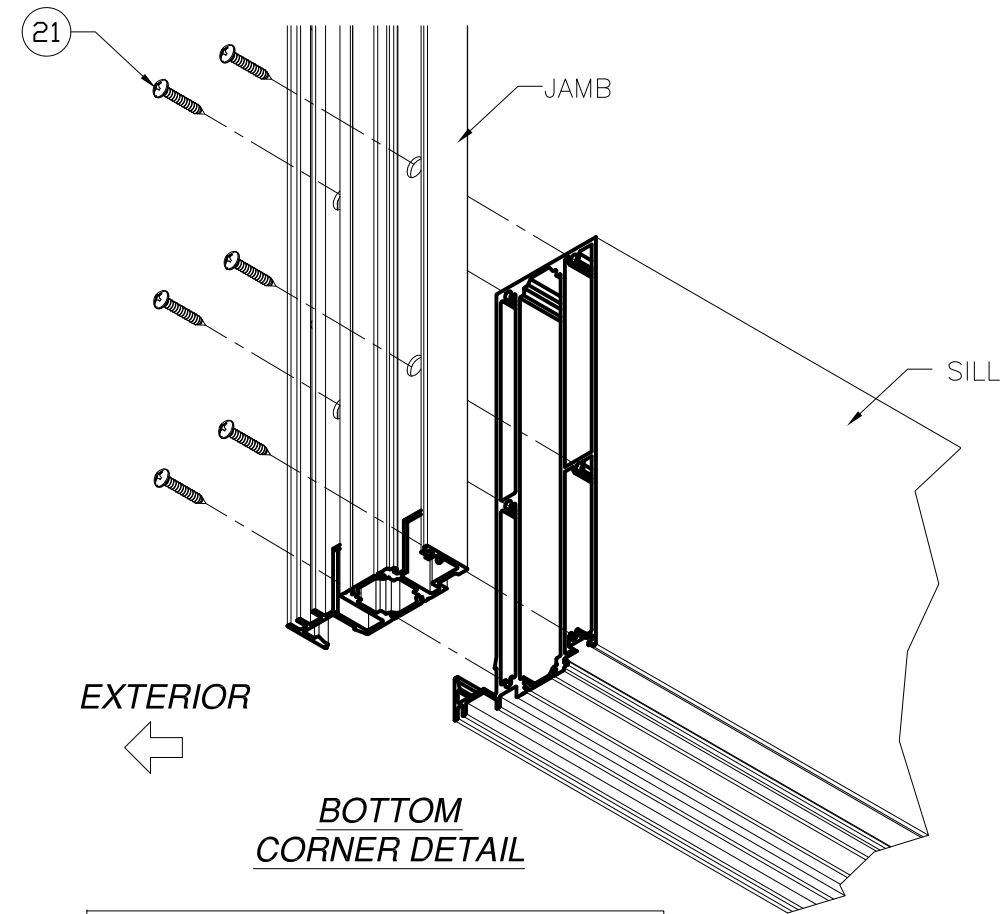

EXTERIOR

BOTTOM CORNER DETAIL

DETAILS SHOWN FOR THE HEAD BUT ALSO APPLY TO THE SILL AND JAMBS.

DETAILS SHOWN FOR THE TALL RAIL AT THE SILL BUT ALSO APPLY TO OTHER FRAME TYPES AND AT OTHER WINDOW CORNERS.

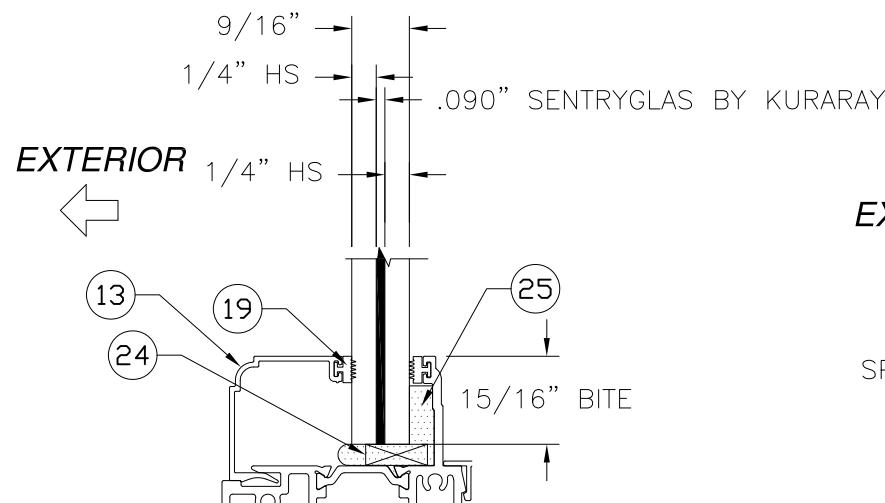

GLAZING DETAIL A

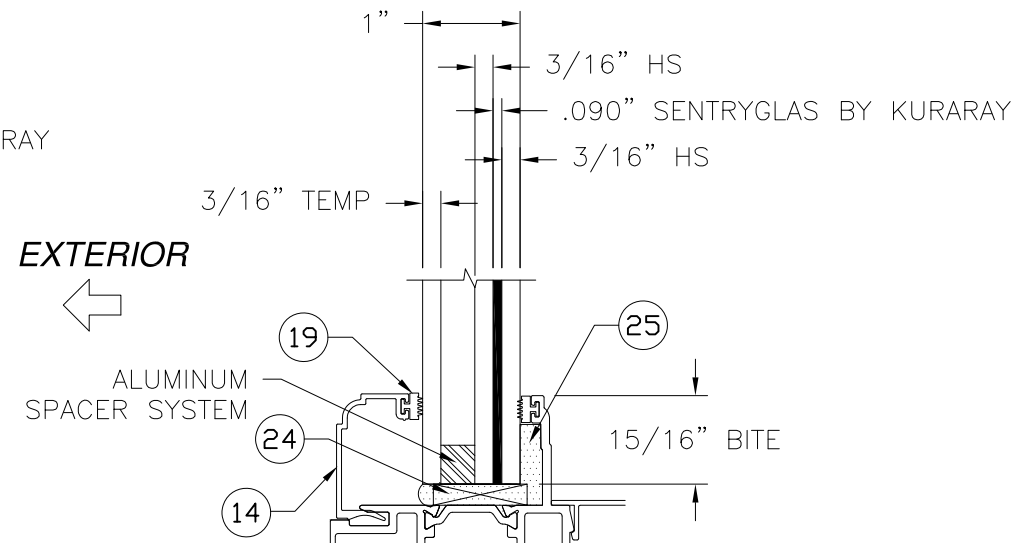

GLAZING DETAIL B

Revision:

PREPARED BY A. LYNN MILLER 1070 TECHNOLOGY DRIVE N. VENICE, FL 34275 (941) 480-1600	COPYRIGHT © 2021 WINDOOR INC. LIMITED LICENSE TO MAKE COPIES FOR PERMITTING.	Date	02/10/21
		Drawn By	J ROSOWSKI
WINDOOR® INCORPORATED WINDOOR INCORPORATED 104 TRIPLE DIAMOND BLVD. N VENICE, FL 34275; (833) 554-5432	THERMALLY-BROKEN PICTURE WINDOW (LM)	DWG No.	TDI-9020-LM-1
		Sheet	7 OF 8
CORNER AND GLAZING DETAILS		Series Desc.	PW9020T

A. Lynn Miller 5/4/21
 A. LYNN MILLER, P.E.
 P.E.# 106954

TABLE 4:

ITEM #	PART NUMBER	DESCRIPTION	MATERIAL
1	902A09-WDI	HEAD AND SILL FLANGE	ALUM. 6063-T6
2	902A11-WDI	JAMB FLANGE	ALUM. 6063-T6
3	902A07-WDI	CAR RAIL FLANGE	ALUM. 6063-T6
4	S-9020A1-WDI	FRAME HEAD & SILL ASSEMBLY	ALUM. 6063-T6
5	S-9020A2-WDI	FRAME JAMB ASSEMBLY	ALUM. 6063-T6
6	S-9020A8-WDI	CA RAIL ASSEMBLY	ALUM. 6063-T6
7	S-9020A3-WDI	MULL ASSEMBLY	ALUM. 6063-T6
8	S-9020A5-WDI	MEDIUM RAIL ASSEMBLY	ALUM. 6063-T6
9	S-9020A6-WDI	TALL RAIL ASSEMBLY	ALUM. 6063-T6
10	FH-06559	MULL INTERIOR REINFORCEMENT	ALUM. 6005-T6
11	FS-06558	MULL EXTERIOR REINFORCEMENT	ALUM. 6005-T6
12	S-49328	SCREW COVER	ALUM. 6063-T6
13	S-49329	9/16" GLASS STOP	ALUM. 6063-T6
14	S-46084	1" GLASS STOP	ALUM. 6063-T6
15	S-46083	1 3/8" GLASS STOP	ALUM. 6063-T6
16	S-49330	FLUSH ADAPTOR	ALUM. 6063-T6
17	2206	INSULBAR	TECATHERM 66GF
18	S-49332	FIN ADAPTOR	ALUM. 6063-T6
19	GSVN-07A	STD. GLAZING VINYL	80 DUROMETER
20		LARGE GLAZING VINYL	80 DUROMETER
21	131014	#8 x 1" SCREW	STAINLESS STEEL
22		#8 x 1-3/4" SCREW	STAINLESS STEEL
23		#12 x 1" SCREW	STAINLESS STEEL
24	121000-12100E	RUBBER SETTING BLOCK	85 DUROMETER
25		GLAZING COMPOUND	SIKAFLEX552, DOW791/983

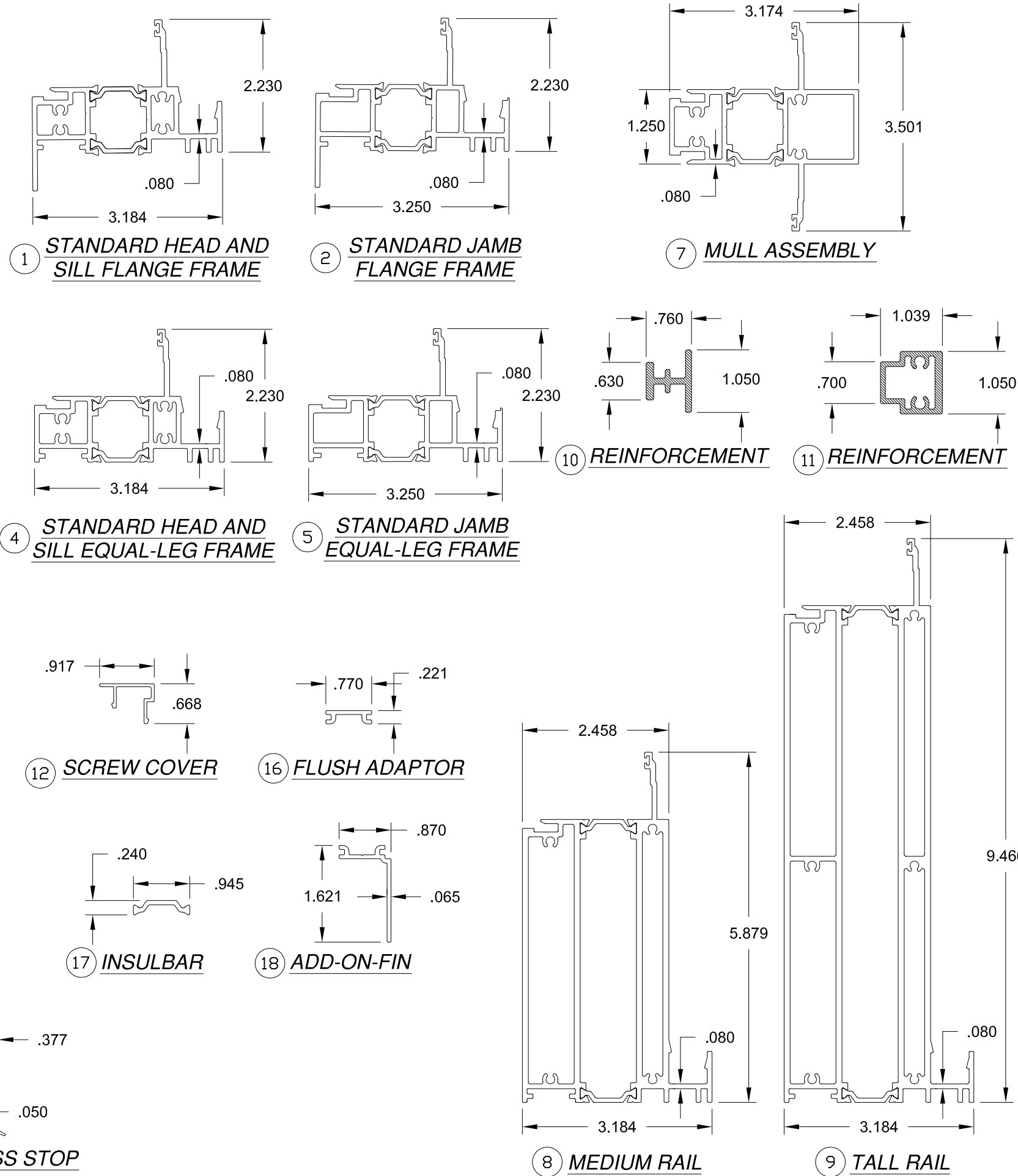

Revision:

PREPARED BY A. LYNN MILLER 1070 TECHNOLOGY DRIVE N. VENICE, FL 34275 (941) 480-1600	COPYRIGHT © 2021 WINDOOR INC. LIMITED LICENSE TO MAKE COPIES FOR PERMITTING.	Date	02/10/21
		By	J ROSOWSKI
WINDOOR® INCORPORATED WINDOOR INCORPORATED 104 TRIPLE DIAMOND BLVD. N VENICE, FL 34275; (833) 554-5432	THERMALLY-BROKEN PICTURE WINDOW (LM)	DWG No.	TDI-9020-LM-1
		Sheet	8 OF 8

Anthony Lynn Miller
 106954
 LICENSED PROFESSIONAL ENGINEER

A. Lynn Miller 5/4/21
 A. LYNN MILLER, P.E.
 P.E.# 106954