

# WINCORE<sup>TM</sup>

## WINDOWS & DOORS

250 Staunton Turnpike, Parkersburg, WV 26104

### 5400/5400S/7700/9900 Series Vinyl Awning Window "NON-IMPACT"

EVALUATED FOR USE IN THE STATE OF TEXAS

**TDI WIN-1134**

The Wincore Awning Window described herein complies with the 2018 International Residential Code (IRC), Sections R301 & R609 and the 2018 International Building Code (IBC), Sections 1404.13, 1609, 1709.5, 2403 and 2404 subject to the following conditions:

1. Anchors shall be as listed and spaced as shown in the details. Anchor embedment to base material shall be beyond wall dressing or stucco.
2. When used in areas requiring wind-borne debris protection this product is required to be protected with an impact resistant covering that complies with Section R301.2.1.2 of the IRC and Section 1609.1.2 of the IBC.
3. Allowable design pressure requirements must be equal to or less than the design pressure rating shown in the design pressure chart, sheet 1 of this drawing.
4. Conditions not covered by this drawing are subject to further engineering analysis.

TABLE OF CONTENTS	
SHEET#	DESCRIPTION
1	Typical elevations, design pressures and general notes
2	Vertical & horizontal cross sections
3	Frame anchoring
4	Bill of materials, components and glazing detail

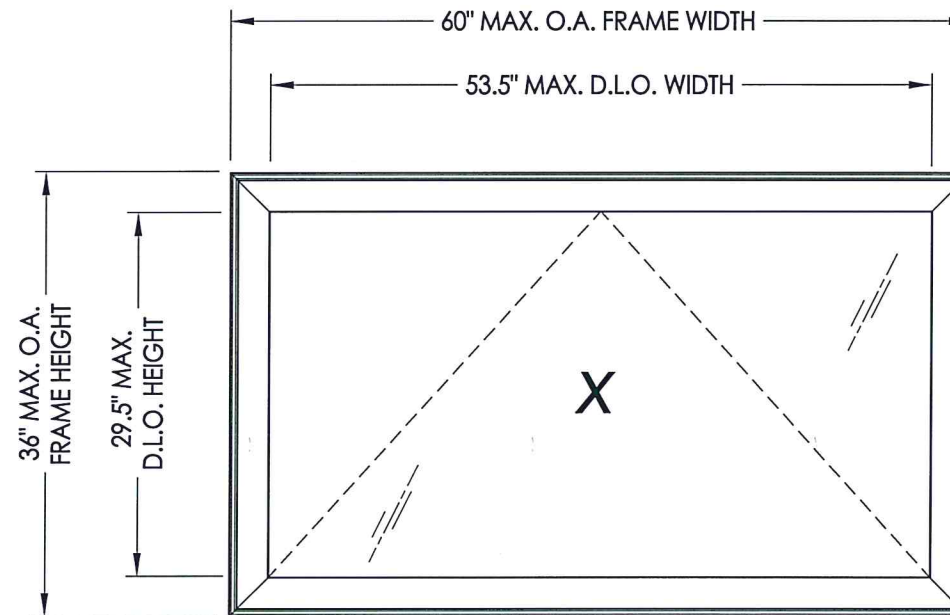

MAX. FRAME DIMENSION	MAX. D.L.O. DIMENSION	GLASS TYPE	DESIGN PRESSURE (PSF)	
			POSITIVE	NEGATIVE
60.0" X 36.0"	53.5" X 29.5"	G1	+50.0	-50.0

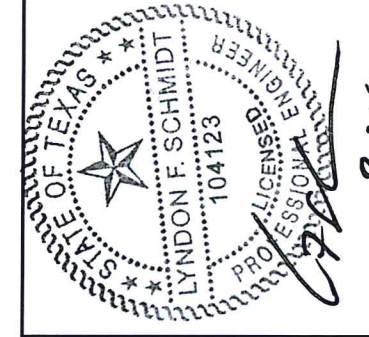

Documents Prepared By: Lyndon F. Schmidt, P.E.  
TEXAS P.E. #104123

**RW** BUILDING CONSULTANTS, INC.  
P.O. Box 230 Valrico FL 33595  
Phone No.: 813.659.9197  
TEXAS BOARD OF PROFESSIONAL ENGINEERS  
CERTIFICATE OF REGISTRATION # F-11852

PRODUCT:	Vinyl Awning Window		
PART OR ASSEMBLY:	TYPICAL ELEVATION, DESIGN PRESSURES & GENERAL NOTES		
NO.	DATE	BY	REVISIONS
1	1/16/20	LFS	UPDATE TO 2018 IRC/IRC & REVISE D.P. TABLE/ANCHORING
DATE: 8/13/14			
SCALE: N.T.S.			
DWG. BY: JK			
CHK. BY: LFS			
DRAWING NO.: TX-4455			
SHEET 1 OF 4			



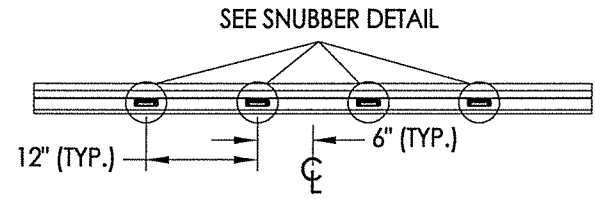

**SNUBBER LOCATIONS**  
 4 Required (Widths > 36")  
 1 Required @ Midspan (Widths <= 36")

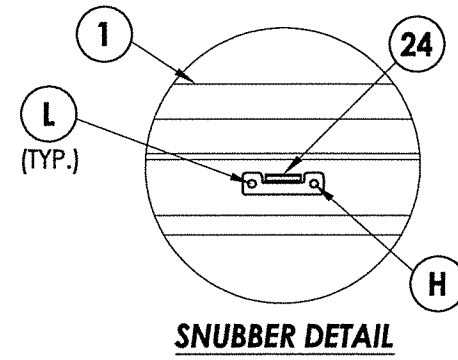

**SNUBBER DETAIL**

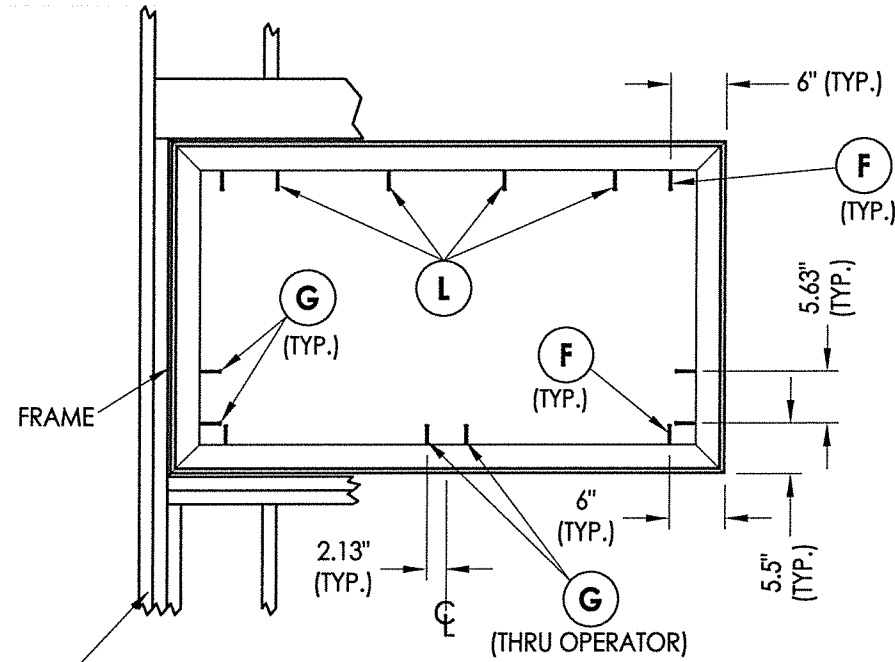

**FRAME ANCHORING**

2X FRAMING TO BE DESIGNED BY THE ENGINEER OR ARCHITECT OF RECORD.

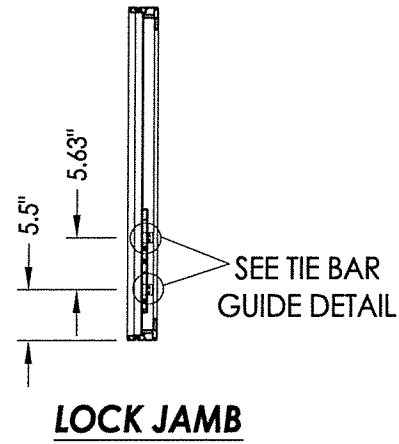

**LOCK JAMB**

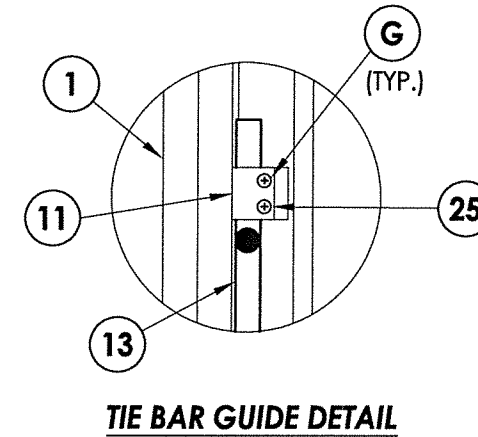

**TIE BAR GUIDE DETAIL**

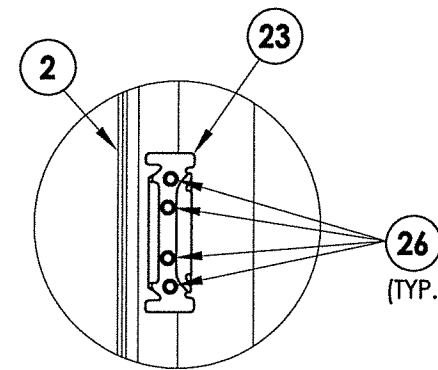

**KEEPER DETAIL**

Located 4" above bottom of each sash

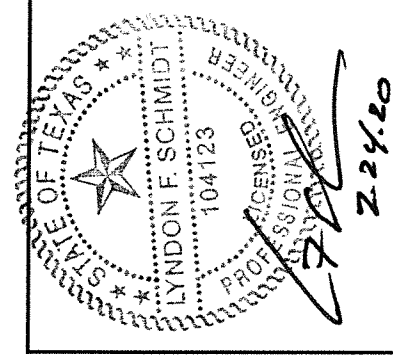

Documents Prepared By: Lyndon F. Schmidt, P.E.  
 TEXAS P.E. #104123  
**RW** BUILDING CONSULTANTS, INC.  
 P.O. Box 230 Valrico FL 33595  
 Phone No.: 813.659.9197  
 TEXAS BOARD OF PROFESSIONAL ENGINEERS  
 CERTIFICATE OF REGISTRATION # F-11852

PRODUCT:		Vinyl Awning Window	
PART OR ASSEMBLY:		FRAME ANCHORING	
NO.	DATE	BY	REVISIONS
1	1/16/20	LFS	UPDATE TO 2018 IBC/IRC & REVISE D.P. TABLE/ANCHORING
DATE: 8/13/14			
SCALE: N.T.S.			
DWG. BY: JK			
CHK. BY: LFS			
DRAWING NO.: TX-4455			
SHEET 3 OF 4			

**BILL OF MATERIALS**

ITEM #	DESCRIPTION	MATERIAL
B	2X FRAMING (SG >= 0.42)	WOOD
C	1/4" MAX. SHIM SPACE	-
F	#8 X 2-1/2" MODIFIED TRUSS HEAD SCREW (1-1/8" MIN. EMBEDMENT)	STEEL
G	#8 X 3" PFH WOOD SCREW (1-3/8" MIN. EMBEDMENT)	STEEL
H	#8 X 3/4" PPH SMS	STEEL
L	#8 X 2-1/2" PPH WOOD SCREW (1-1/2" MIN. EMBEDMENT)	STEEL
1	FRAME*	PVC
2	SASH*	PVC
3	GLAZING BEAD*	PVC
7	WEATHERSTRIP AMESBURY (CS 120 33-SEAL)	FOAM
8	WEATHERSTRIP AMESBURY (12300 SEAL)	VINYL
9	WEATHERSTRIP ULTRA FAB .250 (PILE - 250 - KP52)	VINYL
10	MULTI-POINT LOCK (TRUTH) W1495-20	-
11	TIE BAR GUIDE (TRUTH) 2008741	-
12	OPERATOR (TRUTH) 2006468	-
13	TIE BAR (TRUTH) 2005287	-
23	KEEPER (TRUTH) W1495-01W11	STEEL
24	SNUBBER (TRUTH) (SASH/FRAME) WCS1-1496-85	-
25	#8 X 1" PFH SMS	STEEL
26	#8 X 1/2" PFH SMS	STEEL

\* THE APPROVED WHITE RIGID PVC EXTERIOR EXTRUSIONS FOR WINDOWS ARE TO BE PRODUCED BY EXTRUDERS LICENSEES IN "CERTIFICATION PROGRAMS FOR RIGID PVC EXTRUSIONS".

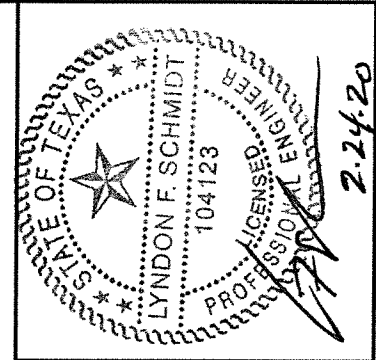

Documents Prepared By: Lyndon F. Schmidt, P.E.  
TEXAS P.E. #104123

**RW** BUILDING CONSULTANTS, INC.  
P.O. Box 230 Valrico FL 33595  
Phone No.: 813.659.9197

TEXAS BOARD OF PROFESSIONAL ENGINEERS  
CERTIFICATE OF REGISTRATION # F-11852

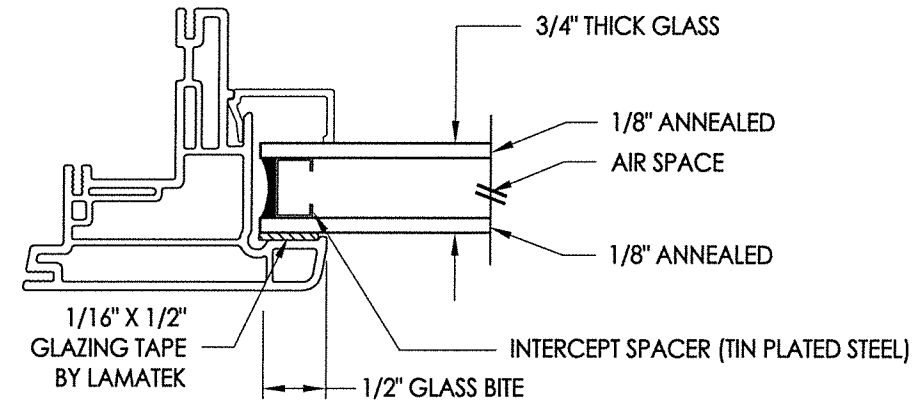

**G1** GLAZING DETAIL

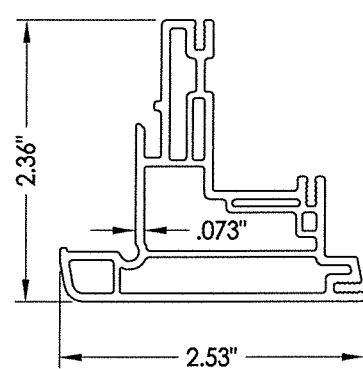

**2** SASH

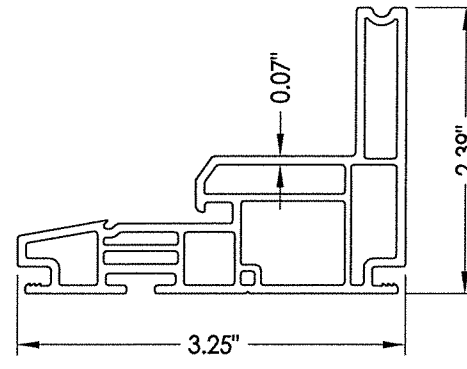

**1** FRAME

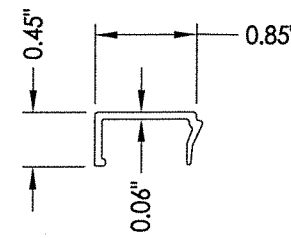

**3** GLAZING BEAD

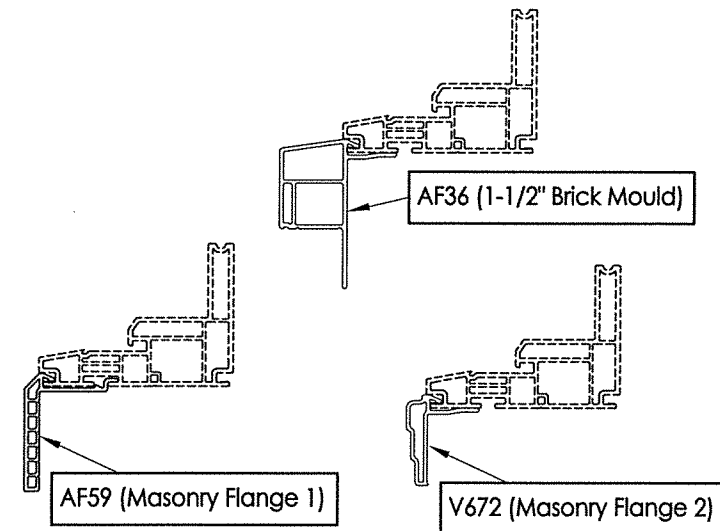

**OPTIONAL COSMETIC FLANGES**

PRODUCT:	Vinyl Awning Window	
PART OR ASSEMBLY:	BILL OF MATERIALS, COMPONENTS AND GLAZING DETAILS	
NO.	DATE	BY
1	1/16/20	LFS
	UPDATE TO 2018 IBC/IRC & REVISE D.P. TABLE/ANCHORING	
REVISIONS		
DATE:	8/13/14	
SCALE:	N.T.S.	
DWG. BY:	JK	
CHK. BY:	LFS	
DRAWING NO.:	TX-4455	
SHEET	4 OF 4	