

Z:\Clients\Associated PERMANENTB - Texas Dept of Ins\Horizontal Slider\WIN 890 3102 Horizontal Slider\C - Drawings\TX-4319-20.dwg

**ASSOCIATED MATERIALS**  
 INCORPORATED  
 3773 STATE ROAD  
 CUYAHOGA FALLS, OH 44223

**MODEL 3102  
 PVC HORIZONTAL SLIDER  
 w/ NAILING FIN  
 "NON-IMPACT"**



Documents Prepared By: Lyndon F. Schmidt, P.E.  
 TEXAS P.E. #104123  
**RW** BUILDING CONSULTANTS, INC.  
 P.O. Box 230 Vairco FL 33595  
 Phone No.: 813.659.9197  
 TEXAS BOARD OF PROFESSIONAL ENGINEERS  
 CERTIFICATE OF REGISTRATION # F-11852

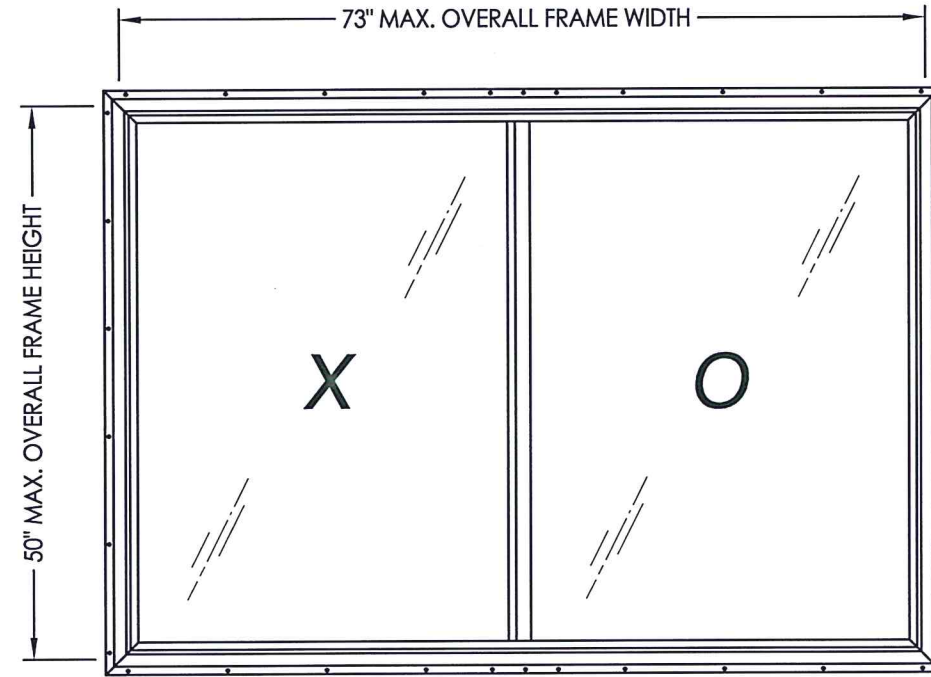

EVALUATED FOR USE IN THE STATE OF TEXAS

**TDI WIN-890**

The Horizontal Slider Window described herein complies with the 2018 International Residential Code (IRC), Sections R301 & R609 and the 2018 International Building Code (IBC), Sections 1404.13, 1609, 1709.5, 2403 and 2404 subject to the following conditions:

1. Anchors shall be as listed and spaced as shown in the details. Anchor embedment to base material shall be beyond wall dressing or stucco.
2. When used in areas requiring wind-borne debris protection this product is required to be protected with an impact resistant covering that complies with Section R301.2.1.2 of the IRC and Section 1609.2 of the IBC.
3. Allowable design pressure requirements must be equal to or less than the design pressure rating shown in the design pressure chart, sheet 1 of this drawing.
4. Conditions not covered by this drawing are subject to further engineering analysis.

TABLE OF CONTENTS	
SHEET#	DESCRIPTION
1	Typical elevations, design pressures & general notes
2	Frame anchoring & cross sections
3	Bill of materials, glazing detail and components

OVERALL FRAME DIMENSION	SASH D.L.O. DIMENSION	FIXED D.L.O. DIMENSION	GLASS TYPE	DESIGN PRESSURE (PSF)	
				POSITIVE	NEGATIVE
73.0" X 50.0"	33.12" X 43.87"	31.62" X 44.0"	G1	+50.0	-50.0

PRODUCT:	HORIZONTAL SLIDER	
PART OR ASSEMBLY:	TYPICAL ELEVATION, DESIGN PRESSURES & GENERAL NOTES	
NO.	DATE	BY
2	8/25/20	LFS
1	6/09/15	LFS
REVISIONS		
DATE:	8/7/13	
SCALE:	N.T.S.	
DWG. BY:	JK	
CHK. BY:	LFS	
DRAWING NO.:	TX-4320	
SHEET	1	OF 3

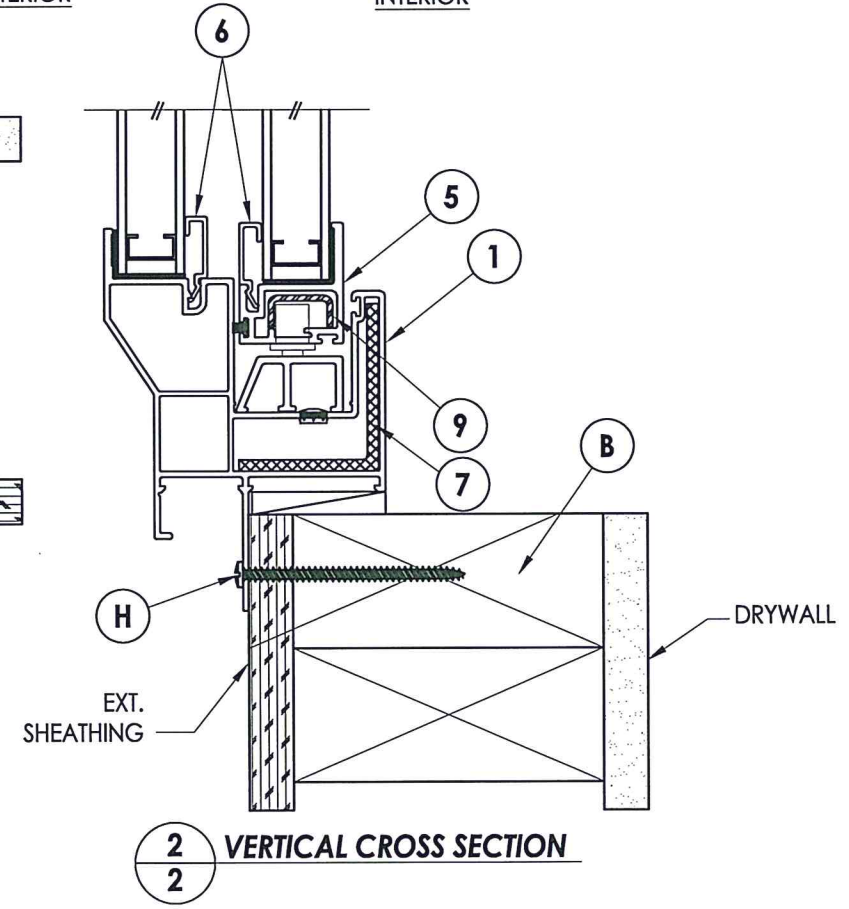
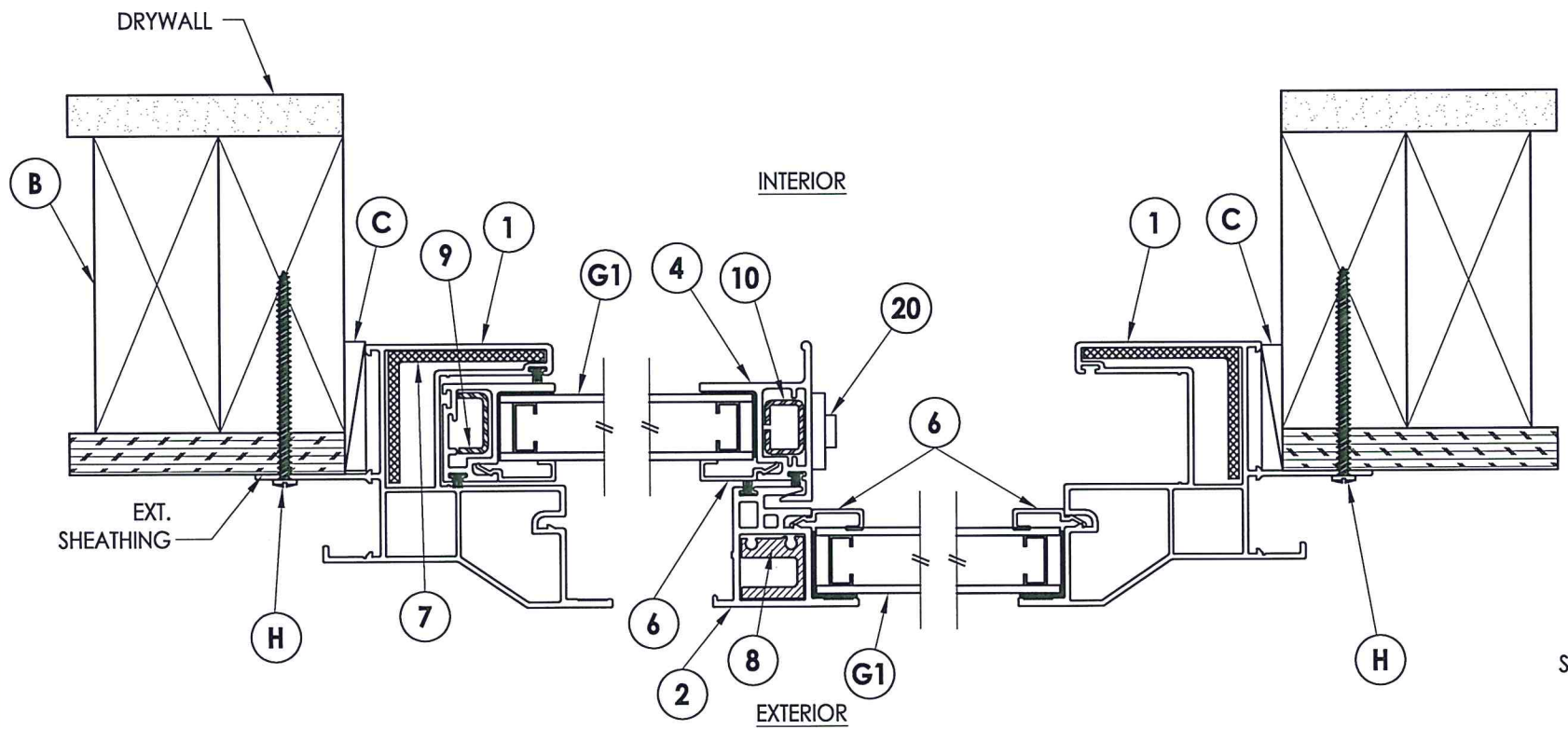
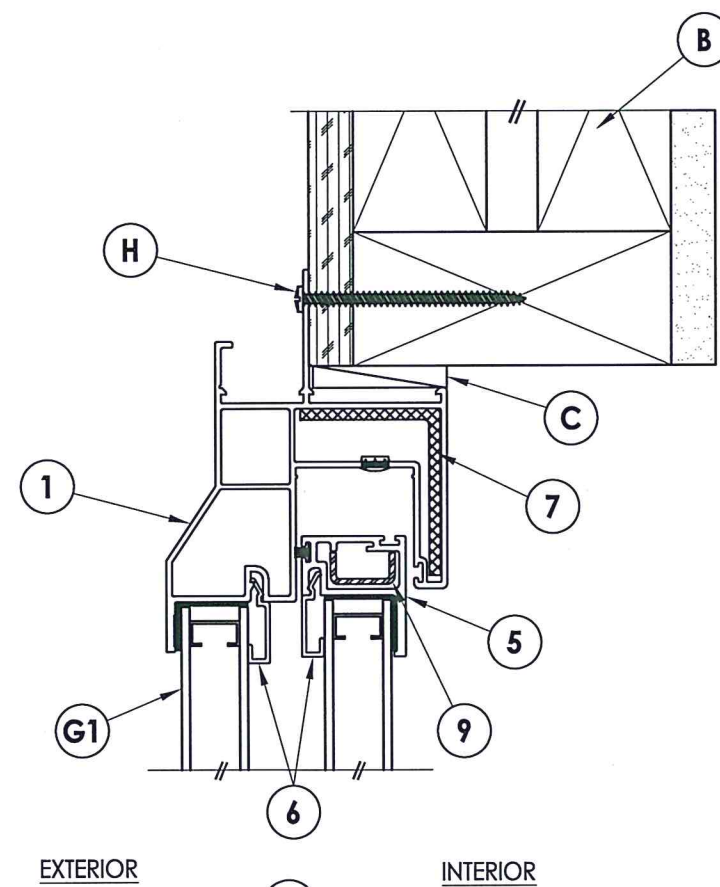
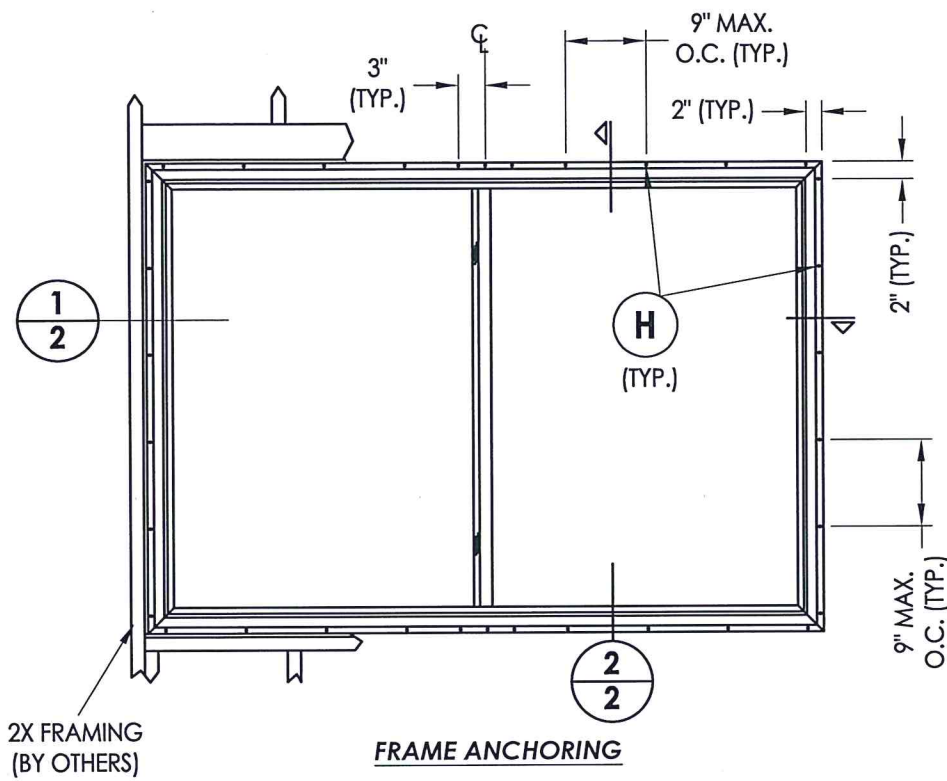

Documents Prepared By: Lyndon F. Schmidt, P.E.  
TEXAS P.E. #104123

**RW** BUILDING CONSULTANTS, INC.  
P.O. Box 230 Valrico FL 33595  
Phone No.: 813.659.9197

TEXAS BOARD OF PROFESSIONAL ENGINEERS  
CERTIFICATE OF REGISTRATION # F-11852

PRODUCT:	HORIZONTAL SLIDER		
PART OR ASSEMBLY:	FRAME ANCHORING & CROSS SECTIONS		
			REVISIONS
		LFS	
2	8/25/20	UPDATE TO 2018 IBC/IRC	
1	6/09/15	REVISED MANUFACTURER/LOGO	
	NO.	DATE	BY
DATE:	8/7/13		
SCALE:	N.T.S.		
DWG. BY:	JK		
CHK. BY:	LFS		
DRAWING NO.:	TX-4320		
SHEET	2	OF	3

BILL OF MATERIALS		
ITEM #	DESCRIPTION	MATERIAL
B	2X FRAMING (SG >= 0.42)	WOOD
C	1/4" MAX. SHIM SPACE	-
H	#8 X 2-1/2" PPH SMS	STEEL
1	EXTRUDED VINYL FRAME *	RIGID PVC
2	EXTRUDED VINYL KEEPER RAIL *	RIGID PVC
4	EXTRUDED VINYL LOCK RAIL *	RIGID PVC
5	EXTRUDED VINYL SASH STILE *	RIGID PVC
6	EXTRUDED VINYL GLAZING BEAD *	RIGID PVC
7	EXTRUDED ALUMINUM FRAME REINFORCEMENT	ALUMINUM
8	EXTRUDED ALUMINUM MULLION REINFORCEMENT	ALUMINUM
9	ROLL FORMED STEEL SASH REINFORCEMENT	STEEL
10	ROLL FORMED STEEL LOCK RAIL REINFORCEMENT	STEEL
17	"U" SHAPED METAL SPACER	STEEL
18	SETTING BLOCK	-
19	STRUCTURAL ADHESIVE SEALANT	SILICONE
20	CAM LOCK & KEEPER (TRUTH)	STEEL

\*THE APPROVED WHITE RIGID PVC EXTERIOR EXTRUSIONS FOR WINDOWS ARE TO BE PRODUCED BY EXTRUDERS LICENSEES IN "AAMA CERTIFICATION PROGRAMS FOR RIGID PVC EXTRUSIONS."

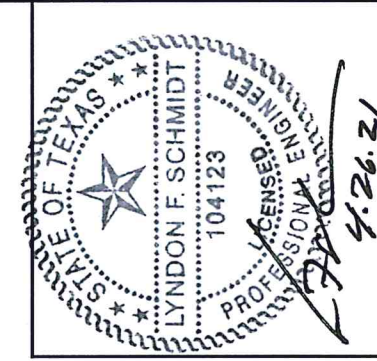

Documents Prepared By: Lyndon F. Schmidt, P.E.  
TEXAS P.E. #104123

**RW** BUILDING CONSULTANTS, INC.  
P.O. Box 230 Vairco FL, 33595  
Phone No.: 813.659.9197

TEXAS BOARD OF PROFESSIONAL ENGINEERS  
CERTIFICATE OF REGISTRATION # F-11852

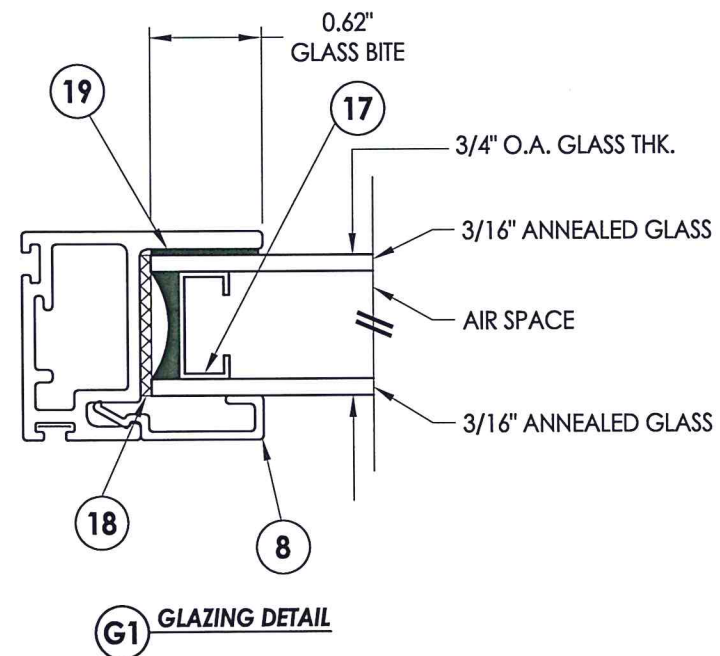
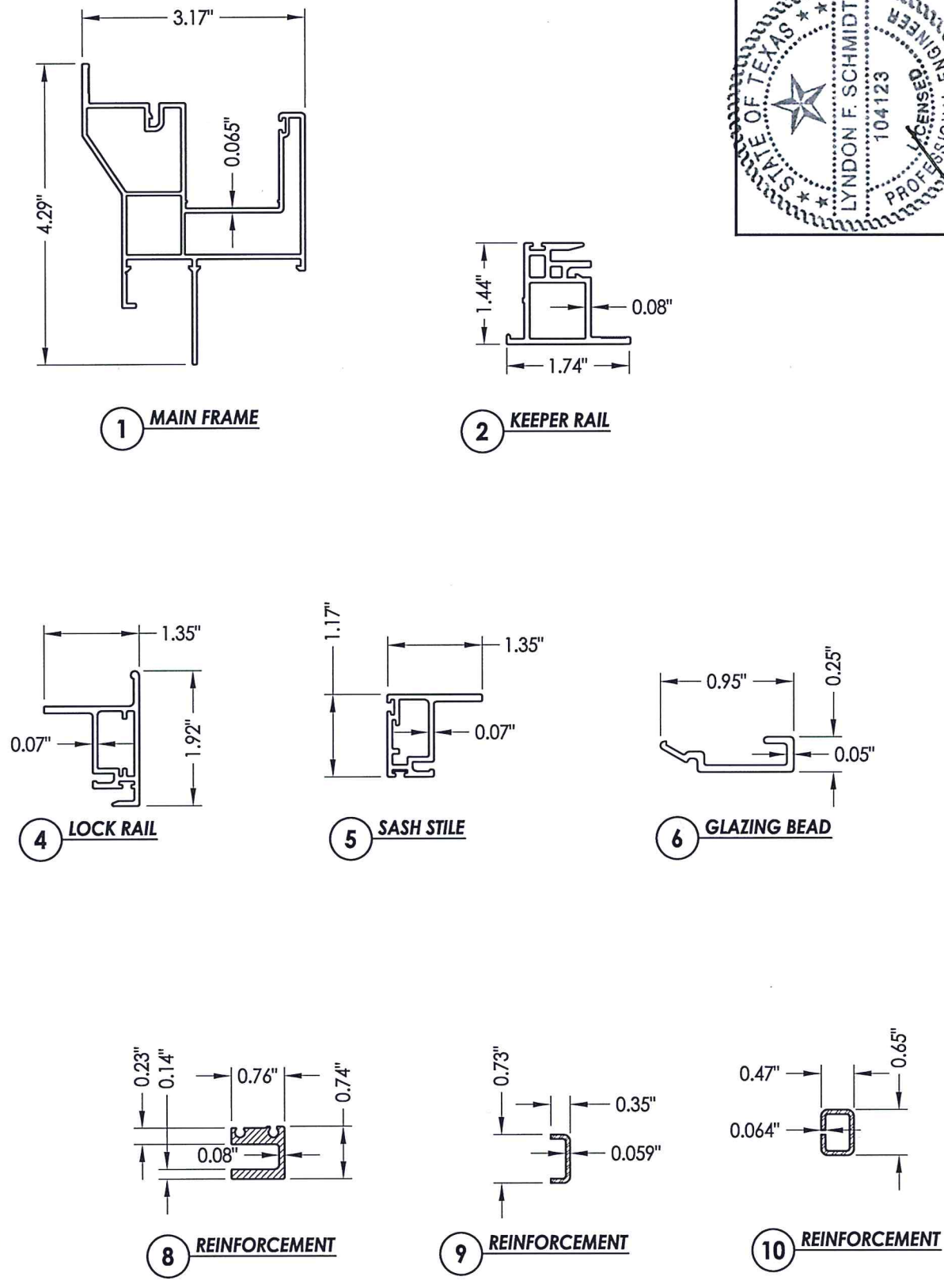

PRODUCT:		HORIZONTAL SLIDER	
PART OR ASSEMBLY:		BILL OF MATERIALS, GLAZING DETAILS & COMPONENTS	
		LFS	BY
		LFS	
REVISIONS			
NO.	DATE		
2	8/25/20	UPDATE TO 2018 IBC/IRC	
1	6/09/15	REVISED MANUFACTURER/LOGO	
DATE			
DATE: 8/7/13			
SCALE: N.T.S.			
DWG. BY: JK			
CHK. BY: LFS			
DRAWING NO.: TX-4320			
SHEET 3 OF 3			