

CASEMENT - LARGE MISSILE IMPACT

GENERAL NOTES:

1. THE PRODUCT SHOWN HEREIN IS DESIGNED AND MANUFACTURED TO COMPLY WITH THE REQUIREMENTS OF THE 2018 INTERNATIONAL BUILDING CODE (IBC) AND 2018 INTERNATIONAL RESIDENTIAL CODE (IRC).
2. GLAZING OPTIONS: (SEE SHEET 2)
3. CONFIGURATIONS: ALL WINDOWS ARE OPEN TO OUTSIDE LEFT OR RIGHT.
4. ANCHORAGE: THE 33 1/3% STRESS INCREASE HAS NOT BEEN USED IN THE DESIGN OF THIS PRODUCT. SEE SHEET 6 FOR INSTALLATION DETAIL. WIND LOAD DURATION FACTOR Cd=1.6 WAS USED FOR WOOD ANCHOR CALCULATIONS.
5. PRODUCTS APPROVED FOR IMPACT RESISTANCE. SHUTTERS ARE NOT REQUIRED.
6. ALL FRAMES AND VENTS FULLY WELDED.
7. SERIES/MODEL DESIGNATION CA-8400.
8. THE DESIGNATION X STANDS FOR THE FOLLOWING:
X = OPERABLE SASH
9. SECTION CALLOUTS APPLY TO ALL ELEVATIONS IN A SIMILAR LOCATION.



1900 SW 44TH AVE.
OCALA, FLORIDA 34474
WWW.CWS.CC

8400 PVC CASEMENT IMPACT

NO.:	DESCRIPTION:	BY:	DATE:
D	REMOVED SYSTEM NUMBERS	MS	01/11/23
C	PROFILES UPDATED	JLD	6/04/21
B	IBC/IRC REF. 2018 UPDATE	JLD	4/09/20
A	REVISED TO TDI REQUEST	JML	3/29/17



2/28/2023

LUCAS A. TURNER, P.E.
TX PE # 115094
TBPE REG. #FL-18075
2428 OLD NATCHEZ TRC TRL
CAMDEN, TN 38320
PH. 941-380-1574

SHEET DESCRIPTION:

GENERAL NOTES AND ELEVATIONS

DRAWN BY:	DATE:
EMK	11/12/15
DWG #:	REV.:
TDI-161	D
SCALE:	SHEET
1:15	1 OF 6

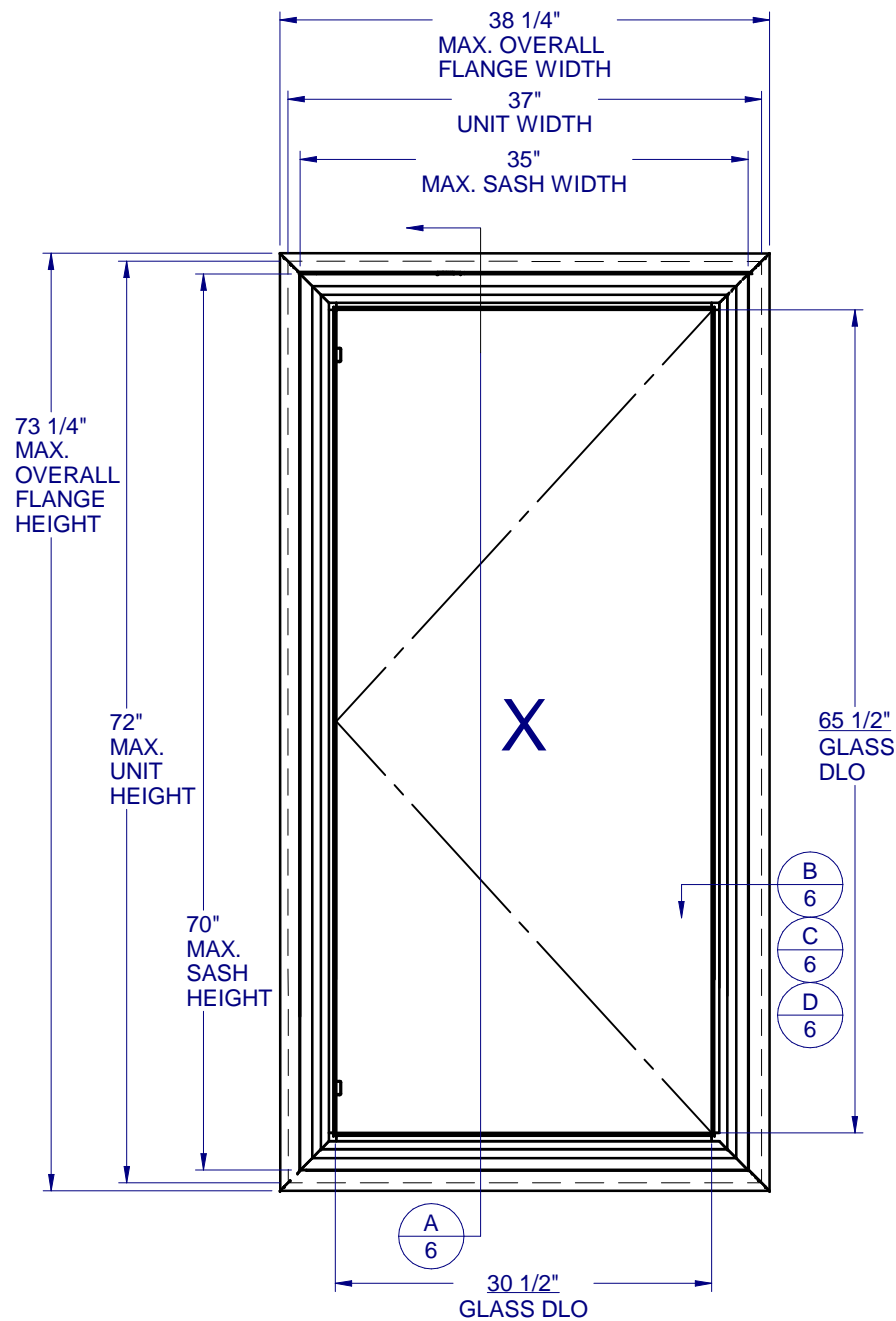

LEFT HINGED - SHOWN ELEVATION A
(CAR 138-276/138-732)

MAXIMUM ALLOWABLE DESIGN PRESSURE: +65/-65 PSF

RIGHT HINGED - OPPOSITE

TABLE OF CONTENTS

GENERAL NOTES & ELEVATIONS.....	1
GLAZING DETAILS.....	2
SECTION VIEWS.....	3
EXTRUSIONS & B.O.M.....	4
ANCHOR SCHEDULE & NOTES.....	5
INSTALLATION DETAILS.....	6

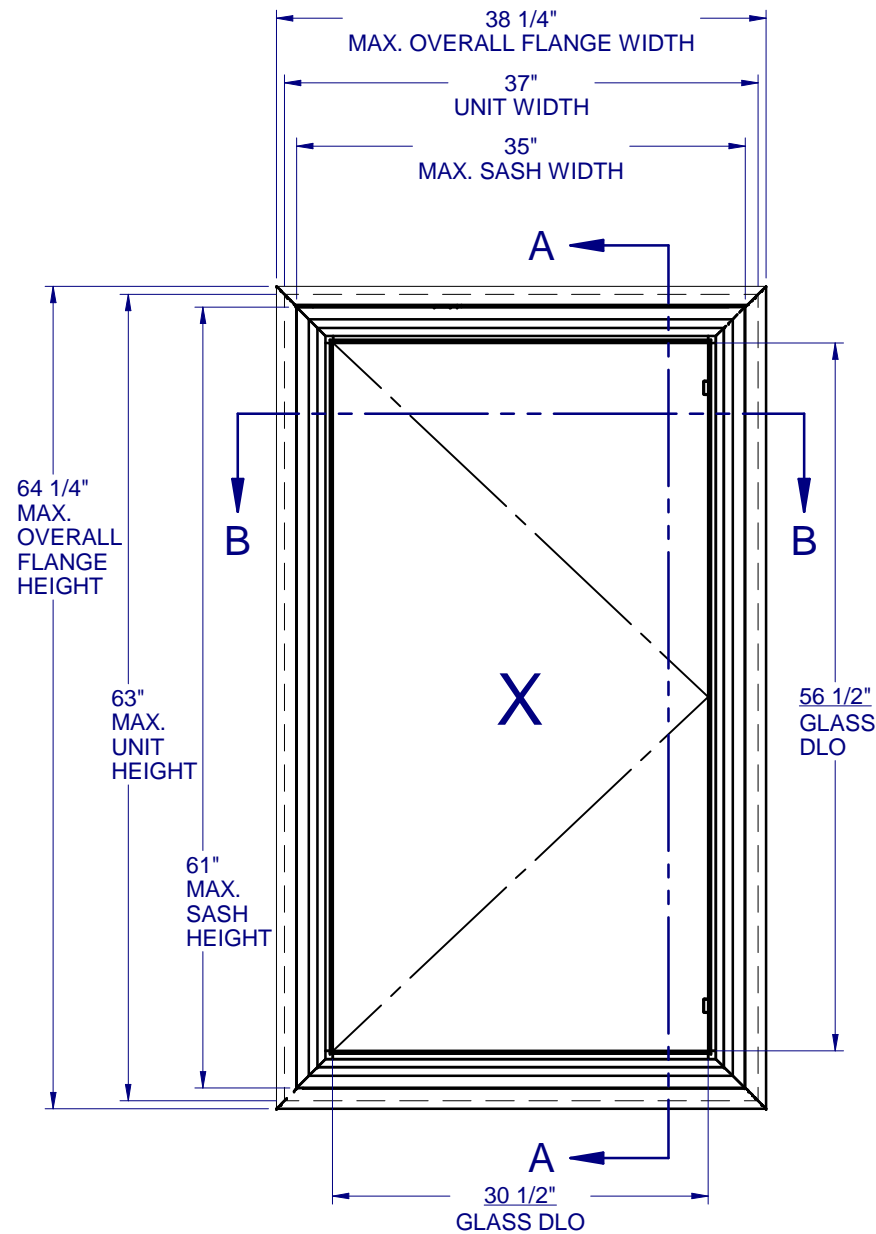

RIGHT HINGED - SHOWN ELEVATION B
(CAR 138-275/138-731)
MAXIMUM ALLOWABLE DESIGN PRESSURE: +65/-65 PSF

LEFT HINGED - OPPOSITE

**8400 PVC
CASEMENT
IMPACT**

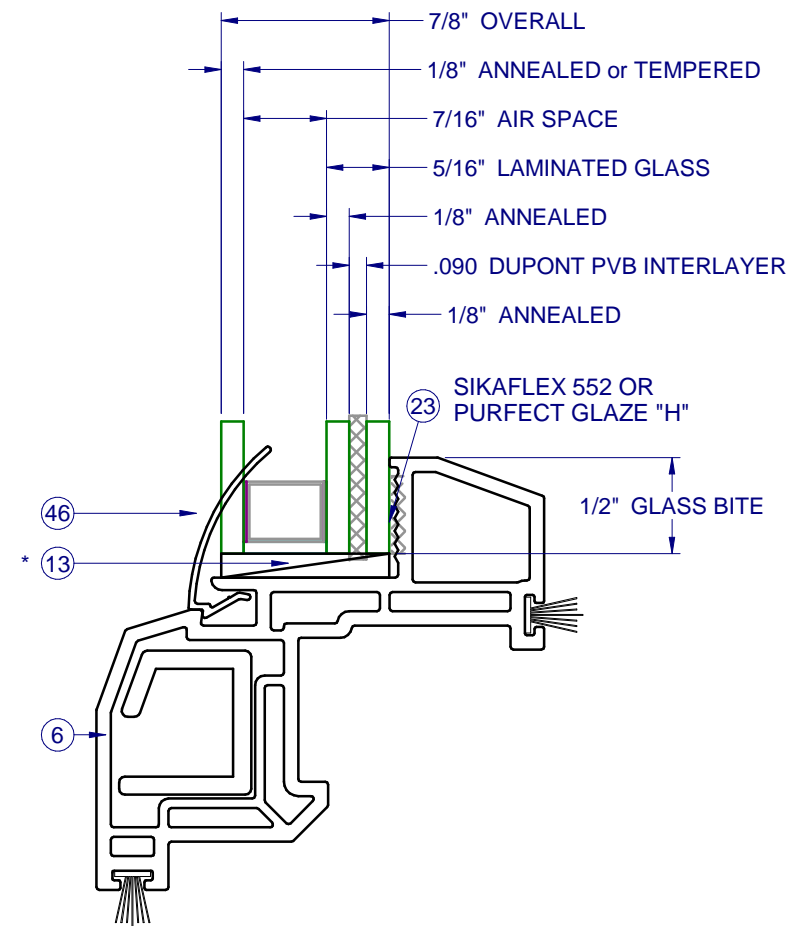

ELEVATION B

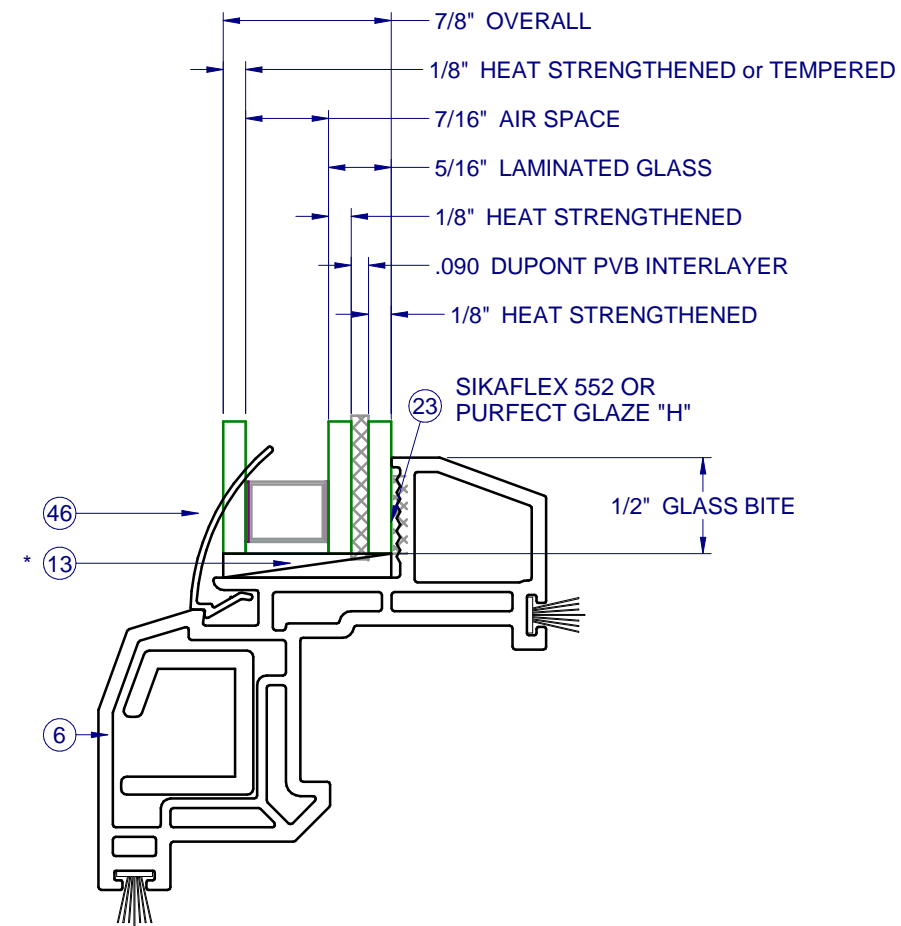

ELEVATION A

NO.:	DESCRIPTION:	BY:	DATE:
D	REMOVED SYSTEM NUMBERS	MS	01/11/23
C	PROFILES UPDATED	JLD	6/04/21
B	IBC/IRC REF. 2018 UPDATE	JLD	4/09/20
A	REVISED TO TDI REQUEST	JML	3/29/17



2/28/2023

LUCAS A. TURNER, P.E.
TX PE # 115094
TBPE REG. #FL-18075
2428 OLD NATCHEZ TRC TRL
CAMDEN, TN 38320
PH. 941-380-1574

SHEET DESCRIPTION:
GLAZING DETAILS

DRAWN BY: EMK	DATE: 11/12/15
DWG #: TDI-161	REV.: D
SCALE: 1:1	SHEET 2 OF 6

**8400 PVC
CASEMENT
IMPACT**

NO.:	DESCRIPTION:	BY:	DATE:
D	REMOVED SYSTEM NUMBERS	MS	01/11/23
C	PROFILES UPDATED	JLD	6/04/21
B	IBC/IRC REF. 2018 UPDATE	JLD	4/09/20
A	REVISED TO TDI REQUEST	JML	3/29/17



2/28/2023

LUCAS A. TURNER, P.E.
TX PE # 115094
TBPE REG. #FL-18075
2428 OLD NATCHEZ TRC TRL
CAMDEN, TN 38320
PH. 941-380-1574

SHEET DESCRIPTION:

SECTION VIEWS

DRAWN BY:	DATE:
EMK	11/12/15
DWG #:	REV.:
TDI-161	D
SCALE:	SHEET
1:2	3 OF 6

INTERIOR

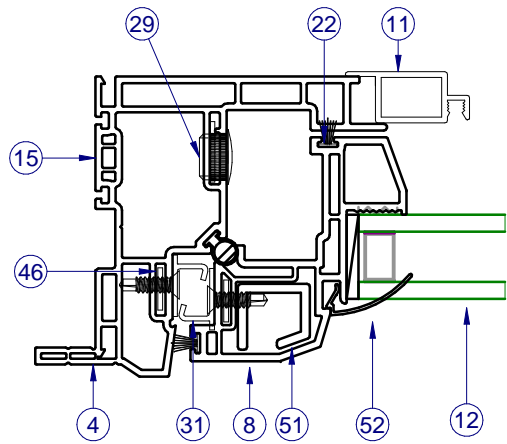

SECTION VIEW B-B

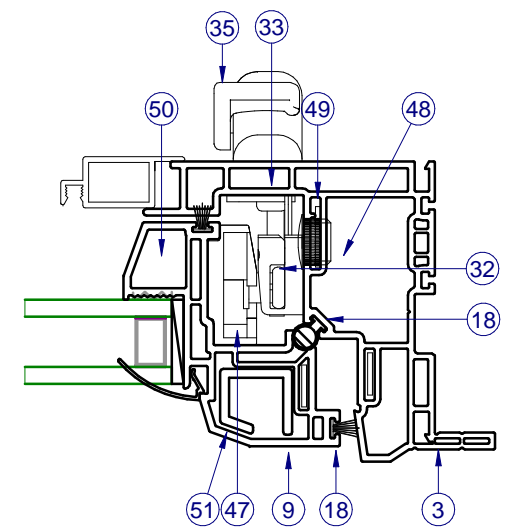

INTERIOR

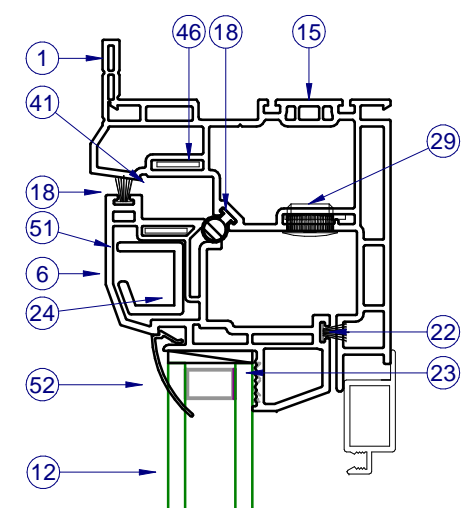

SECTION VIEW A-A

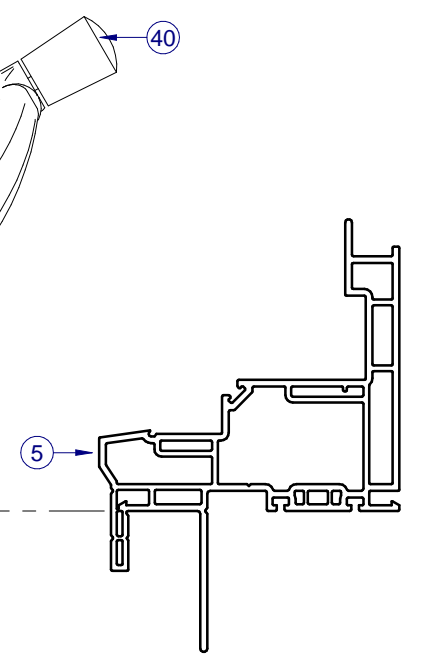

ALTERNATE FIN FRAME

ITEMS NOT SHOWN FOR CLARITY:
14, 16-17, 19-20, 25, 27, 32, 34, 37-38, 42, 44-45, 50

PARTS LIST			
ITEM	PART #	DESCRIPTION	MATERIAL
1	H-6235	FR., CASE., MAIN, HEAD	PVC
2	H-6235	FR., CASE., MAIN, SILL	PVC
3	H-6235	FR., CASE., MAIN, JB., RIGHT	PVC
4	H-6235	FR., CASE., MAIN, JB., LEFT	PVC
5	H-6235	FR., CASE., W/ FIN	PVC
6	H-6234	SASH, CASE., TOP RAIL	PVC
7	H-6234	SASH, CASE., BOT. RAIL	PVC
8	H-6234	SASH, CASE., SIDE RAIL, HINGE	PVC
9	H-6234	SASH, CASE., SIDE RAIL, LOCK	PVC
10	H-1592	SCREEN RAIL, SIDE/BTM	ALUM
11	H-1593	SCREEN RAIL, TOP/SIDE	ALUM
12	GLASS	SEE SHEET 2	
13	P-5615	SET. BLK., 85 DUR., 1/8" X 1" X 2" LG.	RUBBER
14	P-3029	SCREEN LIFT-OUT	
16	P-3195	SCREEN SPRING, NO HOLE TENSION	
17	P-3197	SCREEN CORNER KEY	NYLON
18	P-5573	WSTP., BULB, HOLLOW, T-SLOT, .187 X .358	RUBBER
19	P-3228	SCREEN SPLINE, .155 DIA, BLK	
20		SPACER, SEE SHEET 3	
21	P-3342	SEAM SEALER, SM-5504	SILICONE
22	P-3429	WSTP., .270 X .187 BACK, ULTRA FIN, BLACK, SASH	
23		PURFECT GLAZE "H", SIKAFLEX 552	
24	P-3539	#8 X 3/4" QUAD PH TEK, ZINC, SCREW	
25	P-3581	SCREEN CLOTH, 18 X 16 FIBERGLASS	
26	P-3587	#8 X 1" PH FH TEK 2, SS, SCREW	SS
27	P-3613	CWS LBL. (LOGO)	
28	P-3685	CS-8400 GOLD CERT. LABEL, NFRC TAB	
29	P-5588	CAP PLUG, 1/2" HOLE	NYLON
30	P-3881	TEMPORARY LBL. (NFRC/DP)	
31	P-3940	SNUBBER, SS, PVC	
32	P-4003	TIE BAR GUIDE, ROTO. HDWE.	SS
33	P-4004	#8-32 X 1/2" PH PH, MS, SS (ROTO HDWE. LOCK)	SS
34	P-4005	SUPPORT PLATE, LOCK, SS, ROTO HDWE. (Use w/ P-4006)	SS
35	P-4006	LOCK, MULTI-POINT, ROTO HDWE., WHITE	SS
36	P-4007	ROTO. OPERATORS (FOR LEFT/RIGHT OPEN CASEMENT)	SS
37	P-4009	TRACK & SLIDER ASSM., ROTO OPER., ROTO HDWE., (13")	SS
38	P-4010	STUD BRKT., ROTO OPER., L.H., ROTO HDWE.	SS
39	P-4012	SHIM, ROTO OPERATOR, ROTO HDWE. (4.8mm)	NYLON
40	P-4053	HANDLE, STD, ROTO OPER, ROTO HDWE. (WHITE)	ZINC
41	P-4018	HINGES (LEFT/RIGHT FOR LEFT OR RIGHT OPEN CASEMENT)	SS
42	P-4020	SUPPORT WASHER, ROTO OPER, ROTO HDWE. (SS)	SS
43	P-4021	#8-32 x 3/4" Quad FH W/ 1/16" Lead, MS, SS, ROTO OP., ROTO HDWE.	SS
44	P-4024	GASKET, ROTO OPER., ROTO HDWE., 1/16"	
45	P-4031-P-4040	TIE-BARS, ROTO HDWE. 1-5 LOCKPOINTS, SS (BY OA HGT.)	SS
46	P-4050	REINF. COIL-ALUMINUM, 5052-H32 (.050 X .437), HD	ALUM
47	P-4043	STRIKE, MULTIPPOINT	NYLON
48	P-4146	#8 x 3/4" PH FLAT TEK, SS	SS
49	P-4491	REINF. COIL-ALUMINUM, 5052-H32 (.062 X .656), HD	ALUM
50	P-4641	#8 x 5/8" PH FLAT TEK, #7 HEAD, SS	SS
51	S-1505	REINF. CASE. SASH	ALUM
52	S-6237	GLZ. BD., 7/8"	PVC

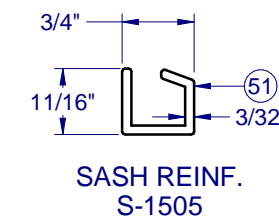
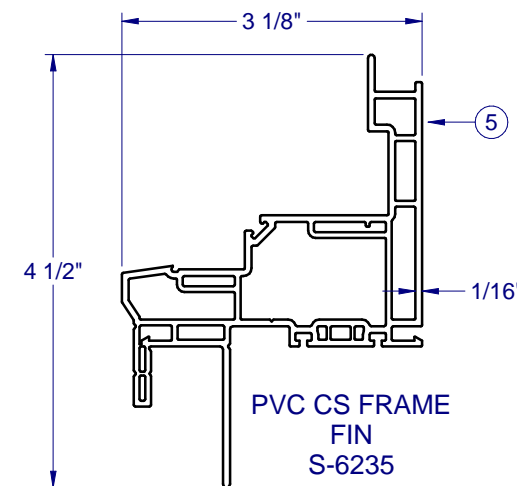
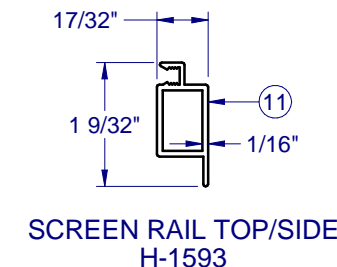
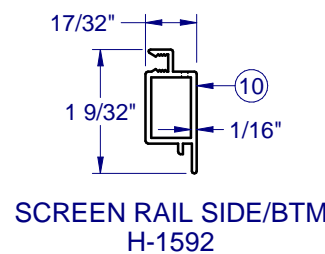
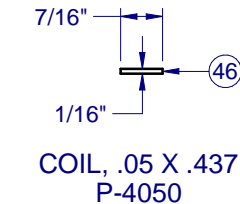
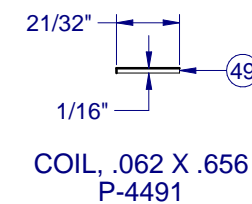
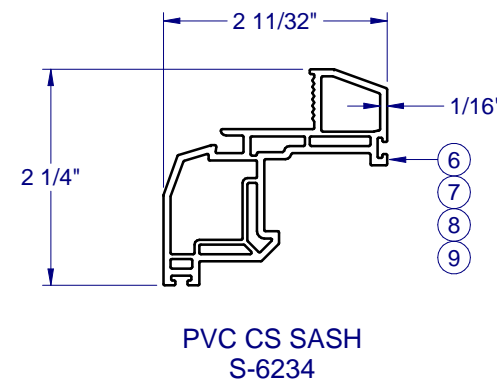
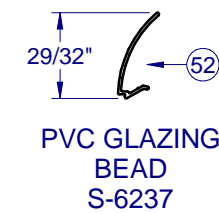
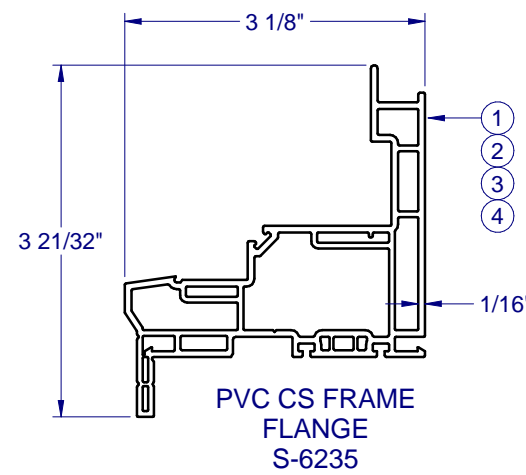

FRAME AND SASH CORNER CONSTRUCTION

CORNER WELD (ALL SIDES) 1:8

Custom WINDOW SYSTEMS

1900 SW 44TH AVE.
OCALA, FLORIDA 34474
WWW.CWS.CC

8400 PVC CASEMENT IMPACT

NO.	DESCRIPTION:	BY:	DATE:
D	REMOVED SYSTEM NUMBERS	MS	01/11/23
C	PROFILES UPDATED	JLD	6/04/21
B	IBC/IRC REF. 2018 UPDATE	JLD	4/09/20
A	REVISED TO TDI REQUEST	JML	3/29/17

2/28/2023

LUCAS A. TURNER, P.E.
TX PE # 115094
TBPE REG. #FL-18075
2428 OLD NATCHEZ TRC TRL
CAMDEN, TN 38320
PH. 941-380-1574

SHEET DESCRIPTION:
BOM AND EXTRUSIONS

DRAWN BY: EMK	DATE: 11/12/15
DWG #: TDI-161	REV.: D
SCALE: 2:1	SHEET 4 OF 6

NOTE: ALL ALUMINUM EXTRUSIONS ARE 6063-T6 UNLESS OTHERWISE NOTED.

**8400 PVC
CASEMENT
IMPACT**

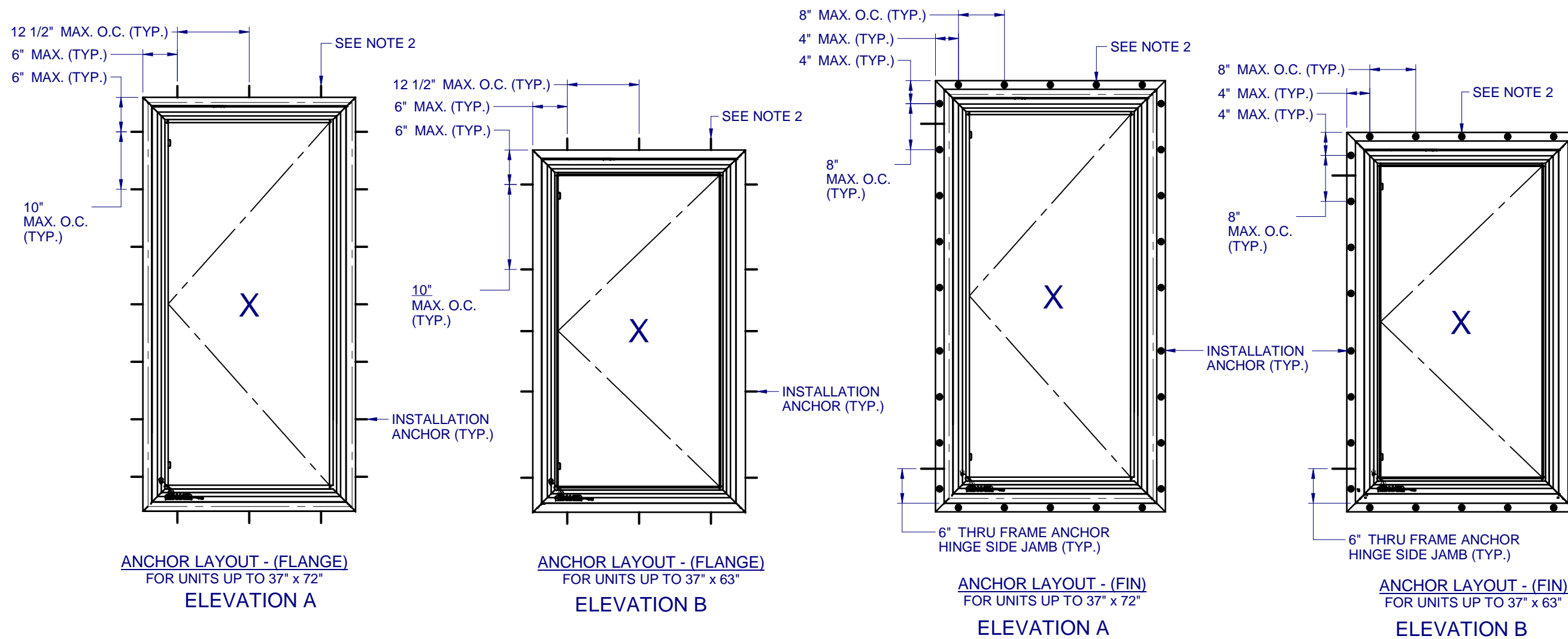

NOTES:

1. INSTALL ONE ANCHOR AT EACH INSTALLATION LOCATION. SILL ANCHOR SPACING SAME AS HEAD. LEFT HINGE SHOWN, RIGHT HINGE SIMILAR.
2. SHIM AS REQ AT EACH INSTALLATION ANCHOR USING LOAD BEARING SHIMS. MAX. ALLOWABLE SHIM STACK TO BE 1/4". USE SHIMS WHERE SPACE GREATER THAN 1/16" IS PRESENT. LOAD BEARING SHIMS SHALL BE CONSTRUCTED OF HIGH DENSITY PLASTIC OR BETTER. WOOD SHIMS ARE NOT ALLOWED.
3. ANCHOR TYPE, SIZE, SPACING AND EMBEDMENT SHALL BE AS SPECIFIED IN THESE DRAWINGS, SEE TABLE 1, SHEET 6.
4. ALL INSTALLATION ANCHORS MUST BE MADE OF OR PROTECTED WITH A CORROSION RESISTANT MATERIAL OR COATING. DISSIMILAR METALS OR MATERIALS IN CONTACT WITH PRESSURE TREATED WOOD MUST BE PROTECTED TO PREVENT REACTION.
5. INSTALLATION ANCHORS SHALL BE IN ACCORDANCE WITH ANCHOR MANUFACTURER'S INSTALLATION INSTRUCTIONS, AND ANCHORS SHALL NOT BE USED IN SUBSTRATES WITH STRENGTHS LESS THAN THE MINIMUM SPECIFIED IN TABLE 1, SHEET 6.
6. ANCHOR EMBEDMENT TO SUBSTRATE SHALL BE BEYOND WALL DRESSING OR STUCCO. FOR CONCRETE/CMU OPENINGS, EMBEDMENT SHALL BE BEYOND WOOD BUCKS, IF USED, INTO SUBSTRATE. INSTALLATIONS TO SOLID CONCRETE OR GROUT-FILLED CMU MAY INCLUDE BUT DO NOT REQUIRE 1X WOOD BUCKS BETWEEN THE PRODUCT AND THE SUBSTRATE. INSTALLATIONS TO HOLLOW CMU REQUIRE THE USE OF 1X BUCKS BETWEEN THE PRODUCT AND SUBSTRATE.
7. A MINIMUM CENTER-TO-CENTER SPACING SHALL BE MAINTAINED BETWEEN ALL FASTENERS: 3" FOR MASONRY, 1" FOR WOOD AND METAL.
8. WOOD OR MASONRY OPENINGS, BUCKS AND BUCK FASTENERS SHALL BE PROPERLY DESIGNED BY THE ARCHITECT OR ENGINEER OF RECORD AND INSTALLED TO TRANSFER WIND LOADS TO THE STRUCTURE. SUBSTRATES SHALL MEET THE MINIMUM STRENGTH REQUIREMENTS AS SHOWN IN TABLE 1, SHEET 6. CONCRETE AND MASONRY SUBSTRATES MAY NOT BE CRACKED.
9. SEALING AND FLASHING STRATEGIES FOR OVERALL WATER RESISTANCE OF INSTALLATION SHALL BE DONE BY OTHERS FOLLOWING THE CURRENT VERSION OF THE REFERENCE DOCUMENTS: FMA/AAMA 100(FIN WINDOWS), FMA/AAMA 200(FLANGE WINDOWS), FMA/WDMA 250(BOX WINDOWS), FMA/AAMA/WDMA 300(EXTERIOR DOORS)

NO.:	DESCRIPTION:	BY:	DATE:
D	REMOVED SYSTEM NUMBERS	MS	01/11/23
C	PROFILES UPDATED	JLD	6/04/21
B	IBC/IRC REF. 2018 UPDATE	JLD	4/09/20
A	REVISED TO TDI REQUEST	JML	3/29/17



2/28/2023

LUCAS A. TURNER, P.E.
TX PE # 115094
TBPE REG. #FL-18075
2428 OLD NATCHEZ TRC TRL
CAMDEN, TN 38320
PH. 941-380-1574

SHEET DESCRIPTION:
ANCHOR SCHEDULE & NOTES

DRAWN BY:	DATE:
EMK	11/12/15
DWG #:	REV.:
TDI-161	D
SCALE:	SHEET
1:20	5 OF 6

**8400 PVC
CASEMENT
IMPACT**

NO.	DESCRIPTION	BY	DATE
D	REMOVED SYSTEM NUMBERS	MS	01/11/23
C	PROFILES UPDATED	JLD	6/04/21
B	IBC/IRC REF. 2018 UPDATE	JLD	4/09/20
A	REVISED TO TDI REQUEST	JML	3/29/17

REVISIONS



2/28/2023

LUCAS A. TURNER, P.E.
TX PE # 115094
TBPE REG. #FL-18075
2428 OLD NATCHEZ TRC TRL
CAMDEN, TN 38320
PH. 941-380-1574

SHEET DESCRIPTION:

INSTALLATION DETAILS

DRAWN BY:	DATE:
EMK	11/12/15
DWG #:	REV.:
TDI-161	D
SCALE:	SHEET
1:2	6 OF 6

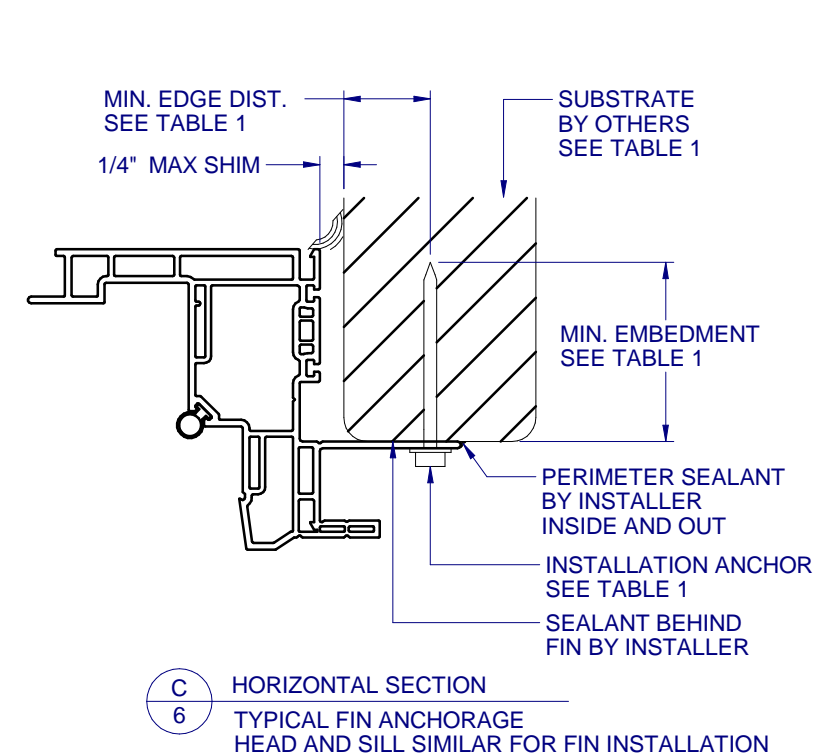
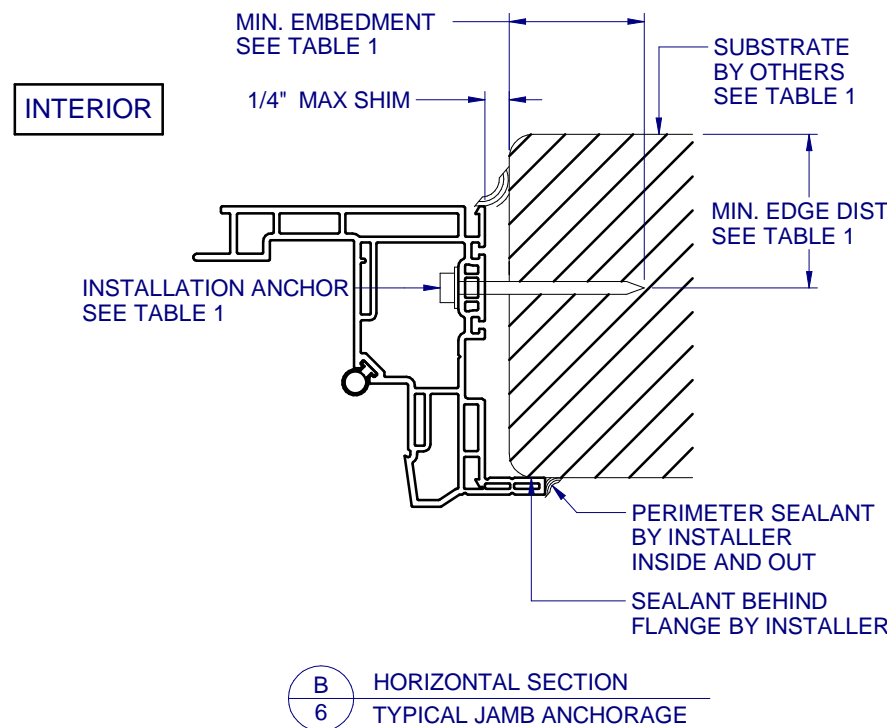
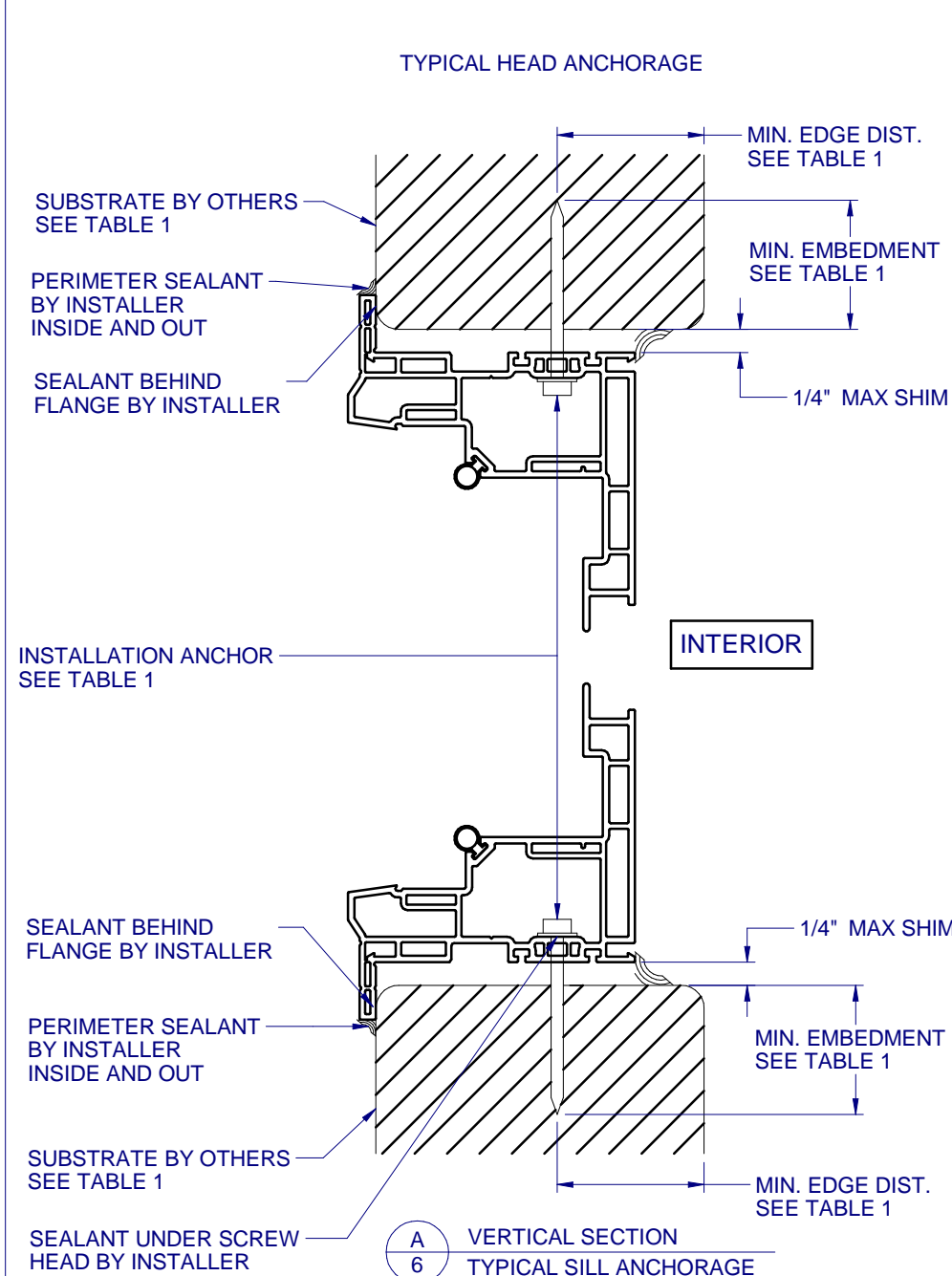

NOTE: ADDITIONAL THRU-FRAME ANCHORS (AS SHOWN IN DET. B/6) REQ'D AT THE HINGE SIDE JAMB, SEE SHEET 5 ANCHOR LAYOUT.

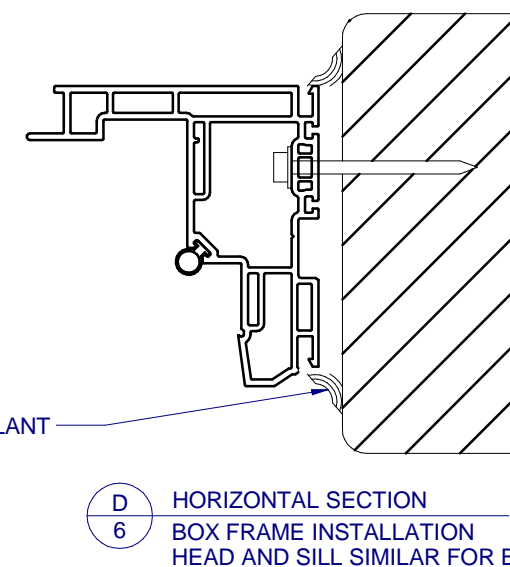

FLANGE REMOVAL NOTE: PARTIALLY OR FULLY REMOVING THE FLANGE, UP TO AND INCLUDING A BOX-FRAME APPLICATION IS ACCEPTABLE PROVIDED:

- MIN. 1/4" FILLET OF CONSTRUCTION-GRADE ADHESIVE CAULK IS APPLIED INSIDE AND OUT, FULL PERIMETER, BY INSTALLER.
- PRODUCT ANCHORAGE IS IN ACCORDANCE WITH REQUIREMENTS AS SHOWN FOR FLANGE WINDOWS.

TABLE 1: APPROVED INSTALLATION FASTENERS

FRAME TYPE	SUBSTRATE TYPE	ANCHOR TYPE	MIN. EMBEDMENT	MIN. EDGE DIST.
FLANGE	CONCRETE (2.0 KSI MIN.)	3/16" ITW TAPCON	1-1/2"	1-1/8"
FLANGE	HOLLOW OR GROUT-FILLED CMU (117 PCF MIN.)	3/16" ITW TAPCON	1"	2"
FLANGE	CONCRETE (2.85 KSI MIN.)	3/16" ELCO ULTRACON	1"	1"
FLANGE	GROUT-FILLED CMU (ASTM C-90)	3/16" ELCO ULTRACON	1-1/4"	2-1/2"
FLANGE	2X MIN. SOUTHERN PINE (G=0.55)	3/16" ITW TAPCON OR ELCO ULTRACON	1-3/8"	7/8"
FLANGE	2X MIN. SOUTHERN PINE (G=0.55)	#10 WOOD SCREW	1-3/8"	7/8"
FLANGE	16 GAUGE (0.060") MIN. STEEL STUD (33 KSI YIELD MIN)	#10-16 HILTI KWIK-FLEX OR ITW TEKS SELF-DRILLING SCREW	FULL THREAD THRU 0.060"	7/16"
FLANGE	1/8" ALUM. (6063-T5 MIN.) OR 1/8" STEEL (33 KSI MIN.)	#10 GRADE 5 SELF-TAPPING / DRILLING SCREW	FULL THREAD THRU 0.125"	7/16"
FIN	2X MIN. SPRUCE-PINE-FIR (G=0.42)	#8 WOOD SCREW	1-1/2"	7/16"