

MolimoTM
Architectural Product Testing

Report #: 1820.05-106-12

Date: 4/12/2019

By: M. Stremmel

			MATERIAL:		 MI WINDOWS AND DOORS, LLC. 650 WEST MARKET STREET ORATZ, PA 17030-0370	DESCRIPTION: 1620 Series Single Hung with Mounting Fin Mainframe	
			FINISH:			PRODUCT: 1620	DATE: 10/26/16
			AREA:			SCALE: 1:2	
			WEIGHT:			PART NUMBER:	
			PERIMETER:		DFTM: BRS		DRAWING NUMBER: CS-000392
A		Added new lift exterior bulb and stile reinf	1/12/17	HAL	The information, design or data shown on this document or electronic media is the exclusive property of MI Windows and Doors, LLC. It is considered confidential and proprietary and is made available for limited use only. Its use or reproduction without the expressed written consent of MI Windows and Doors, LLC., is prohibited.		
LTR	ECH #	REVISIONS	DATE	BY			

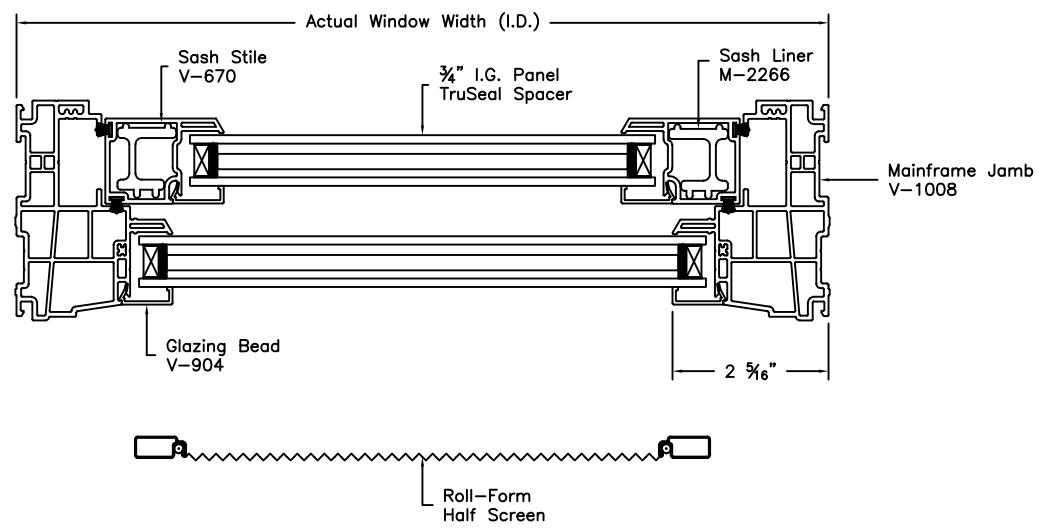
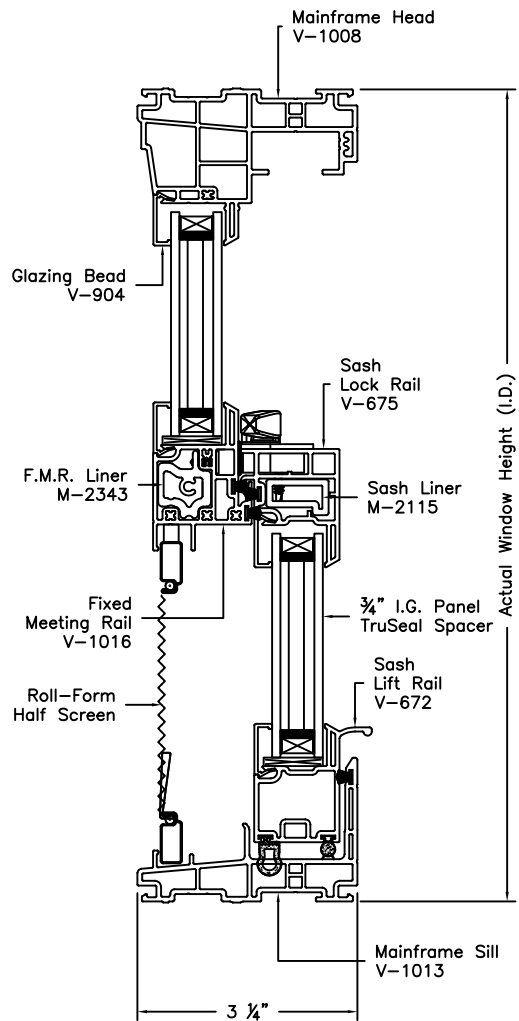

Molimo™
Architectural Product Testing

Report #: 1820.05-106-12

Date: 4/12/2019

By: M. Stremmel

		MATERIAL:		 MI MI WINDOWS AND DOORS, LLC. 650 WEST MARKET STREET GRATZ, PA 17030-0370	DESCRIPTION: 1620 Series Single Hung with Finless Mainframe		
		FINISH:	UNSPECIFIED WALL:		PRODUCT: 1620	DATE: 10/26/16	
		AREA:	BREAK ALL CORNERS R.015, UNLESS OTHERWISE SPECIFIED		SCALE: 1:2	PART NUMBER:	
		WEIGHT:			The information, design or data shown on this document or electronic media is the exclusive property of MI Windows and Doors, LLC. It is considered confidential and proprietary and is made available for limited use only. Its use or reproduction without the expressed written consent of MI Windows and Doors, LLC., is prohibited.	DFTM: BRS	DRAWING NUMBER: CS-000393
		PERIMETER:					
A		Added new lift exterior bulb and stile reinf	1/12/17	HAL			
LTR	ECN #	REVISIONS	DATE	BY			

	B	C	D	E	F
1	1620 Single Hung - Bill of Materials	Last update: 03/20/19			
2					
3	Description	MIWD Part No.	Vendor Part No.	Rev.	CAD
4	Mainframe:				
5	Finless:				
6	Mainframe Head/Jamb, Finless, 240" - Almond	V010080A	V-1008	-	Y
7	Mainframe Head/Jamb, Finless, 240" - White	V010080C	V-1008	-	Y
8	Mainframe Head/Jamb, Finless, 240" - Clay	V010080D	V-1008	-	Y
15	Mainframe Head/Jamb, Finless 240" - Bronze (Ext), White (Int) Open Accessory Groove	V010080B	V-1008	-	Y
16	Mainframe Head/Jamb, Finless 240" - Black (Ext), White (Int) Open Accessory Groove	V010080L	V-1008	-	Y
17					
18	Mainframe Sill, Finless, w/ 187"x240" Weatherstrip, Gray, 240" - Almond	V010130A	V-1013	-	Y
19	Mainframe Sill, Finless, w/ 187"x240" Weatherstrip, White, 240" - White	V010130C	V-1013	-	Y
20	Mainframe Sill, Finless, w/ 187"x240" Weatherstrip, Gray, 240" - Clay	V010130D	V-1013	-	Y
27	Mainframe Sill, Finless, w/ 187"x240" Weatherstrip, White 240" - Bronze (Ext), White (Int) Open Acc Groove	V010130B	V-1013	-	Y
28	Mainframe Sill, Finless, w/ 187"x240" Weatherstrip, White 240" - Black (Ext), White (Int) Open Acc Groove	V010130L	V-1013	-	Y
29					
30	Fin:				
31	Mainframe Head/Jamb, Fin, 240" - Almond	V010070A	V-1007	-	Y
32	Mainframe Head/Jamb, Fin, 240" - White	V010070C	V-1007	-	Y
33	Mainframe Head/Jamb, Fin, 240" - Clay	V010070D	V-1007	-	Y
40	Mainframe Head/Jamb, Fin, 240" - Bronze (Ext), White (Int) Open Accessory Groove	V010070B	V-1007	-	Y
41	Mainframe Head/Jamb, Fin, 240" - Black (Ext), White (Int) Open Accessory Groove	V010070L	V-1008	-	Y
42					
43	Mainframe Sill, Fin, w/ 187"x240" Weatherstrip, Gray, 240" - Almond	V010120A	V-1012	-	Y
44	Mainframe Sill, Fin, w/ 187"x240" Weatherstrip, White, 240" - White	V010120C	V-1012	-	Y
45	Mainframe Sill, Fin, w/ 187"x240" Weatherstrip, Gray, 240" - Clay	V010120D	V-1012	-	Y
52	Mainframe Sill, Fin, w/ 187"x240" Weatherstrip, White 240" - Bronze (Ext), White (Int) Open Acc Groove	V010120B	V-1012	-	Y
53	Mainframe Sill, Fin, w/ 187"x240" Weatherstrip, White 240" - Black (Ext), White (Int) Open Acc Groove	V010120L	V-1012	-	Y
54					
55	Fin w/J: (NOT RELEASED)				
77					
78	Flange:				
79	Mainframe Head/Jamb, Flange, 240" - Almond	V010100A	V-1010	-	Y
80	Mainframe Head/Jamb, Flange, 240" - White	V010100C	V-1010	-	Y
81	Mainframe Head/Jamb, Flange, 240" - Clay	V010100D	V-1010	-	Y
88	Mainframe Head/Jamb, Flange, 240" - Bronze (Ext), White (Int) Veka Filled Accessory Groove	V010100B	V-1010	-	Y
89	Mainframe Head/Jamb, Flange, 240" - Black (Ext), White (Int) Veka Filled Accessory Groove	V010100L	V-1010	-	Y
90					
91	Mainframe Sill, Flange, w/ 187"x240" Weatherstrip, Gray, 240" - Almond	V010150A	V-1015	-	Y
92	Mainframe Sill, Flange, w/ 187"x240" Weatherstrip, White, 240" - White	V010150C	V-1015	-	Y
93	Mainframe Sill, Flange, w/ 187"x240" Weatherstrip, Gray, 240" - Clay	V010150A	V-1015	-	Y
100	Mainframe Sill, Flange, w/ 187"x240" Weatherstrip, White 240" - Bronze (Ext), White (Int) Open Acc Groove	V010150B	V-1015	-	Y
101	Mainframe Sill, Flange, w/ 187"x240" Weatherstrip, White 240" - Black (Ext), White (Int) Open Acc Groove	V010150L	V-1015	-	Y
102					
103	J-Hook, Reinforced, Left	HD006130	14065-999	-	N
104	J-Hook, Reinforced, Right	HD006140	14066-999	-	N
105					
106	J-Hook Screw, #8 x 5/8" PFH, Steel 410 AB Mill	FS001270		-	N
107	J-Hook Screw, Installation, #8 x 2" PPH, SMS, SS (Ship Out with Impact Units)				
108					
109	Accessory Groove Filler, Mull, 240" MI Almond	V649002A	GV6490A240		Y
110	Accessory Groove Filler, Mull, 240" MI White	V649002C	GV6490C240		Y
111	Accessory Groove Filler, Mull, 240" Clay	V649002D	GV6490D240		Y
112	Accessory Groove Filler, Mull, 240" Bronze	V649002B			Y
113	Accessory Groove Filler, Mull, 240" Black	V649002L			Y
114					
115	Balance, 3 LB, Inverted Coil Single, 150/BX	BL500310	24C0009103		N
116	Balance, 4 LB, Inverted Coil Single, 150/BX	BL500311	24C0009104		N
117	Balance, 5 LB, Inverted Coil Single, 150/BX	BL500312	24C0009105		N
118	Balance, 6 LB, Inverted Coil Single, 150/BX	BL500313	24C0009106		N
119	Balance, 7 LB, Inverted Coil Single, 150/BX	BL500314	24C0009107		N
120	Balance, 8 LB, Inverted Coil Single, 150/BX	BL500315	24C0009108		N
121	Balance, 9 LB, Inverted Coil Single, 150/BX	BL500316	24C0009109		N
122	Balance, 10 LB, Inverted Coil Single, 150/BX	BL500317	24C0009110		N
123	Balance, 11 LB, Inverted Coil Double, 100/BX	BL500318	24C0009211		N
124	Balance, 12 LB, Inverted Coil Double, 100/BX	BL500319	24C0009212		N
125	Balance, 13 LB, Inverted Coil Double, 100/BX	BL500320	24C0009213		N
126	Balance, 14 LB, Inverted Coil Double, 100/BX	BL500321	24C0009214		N
127	Balance, 15 LB, Inverted Coil Double, 100/BX	BL500322	24C0009215		N
128	Balance, 16 LB, Inverted Coil Double, 100/BX	BL500323	24C0009216		N
129	Balance, 17 LB, Inverted Coil Double, 100/BX	BL500324	24C0009217		N
130	Balance, 18 LB, Inverted Coil Double, 100/BX	BL500325	24C0009218		N
131	Balance, 19 LB, Inverted Coil Double, 100/BX	BL500326	24C0009219		N
132	Balance, 20 LB, Inverted Coil Double, 100/BX	BL500327	24C0009220		N
133	Balance, 21 LB, Inverted Coil Triple, 50/BX	BL500328	24C0009321		N
134	Balance, 22 LB, Inverted Coil Triple, 50/BX	BL500329	24C0009322		N
135	Balance, 23 LB, Inverted Coil Triple, 50/BX	BL500330	24C0009323		N
136	Balance, 24 LB, Inverted Coil Triple, 50/BX	BL500331	24C0009324		N
137	Balance, 25 LB, Inverted Coil Triple, 50/BX	BL500332	24C0009325		N
138	Balance, 26 LB, Inverted Coil Triple, 50/BX	BL500333	24C0009326		N
139	Balance, 27 LB, Inverted Coil Triple, 50/BX	BL500334	24C0009327		N
140	Balance, 28 LB, Inverted Coil Triple, 50/BX	BL500335	24C0009328		N
141	Balance, 29 LB, Inverted Coil Triple, 50/BX	BL500336	24C0009329		N
142	Balance, 30 LB, Inverted Coil Triple, 50/BX	BL500337	24C0009330		N
143					
144	Balance Clip Screw, #8 x 5/8" PFH, Steel 410 AB Mill	FS001270		-	N
145					
146	Dust Pad, 1" Die Cut 1.7 LB Poly Foam (White)	WS30280C		-	Y
147					
148	Vent Stop, Push Button - Almond	L000091A	1760_109	-	N
149	Vent Stop, Push Button - White	L000091C	1760_005	-	N
150	Vent Stop, Push Button - Clay	L000091D	1760_005	-	N
152					
153	Operable Screen Track No Leg 180" Vertical (Aluminum) Mill Wht WP .187x.210	M2341000	M-2341		Y
154	Operable Screen Track No Leg 180" Vertical (Aluminum) White Wht WP .187x.210	M234100A	M-2341		Y
155	Operable Screen Track No Leg 180" Vertical (Aluminum) Almond Gry WP .187x.210	M234100C	M-2341		Y
156	Operable Screen Track No Leg 180" Vertical (Aluminum) Clay Gry WP .187x.210	M234100D	M-2341		Y
157	Operable Screen Track No Leg 180" Vertical (Aluminum) Black Wht WP .187x.210	M234100L	M-2341		Y
158	Operable Screen Track No Leg 180" Vertical (Aluminum) Bronze Wht WP .187x.210	M234100B	M-2341		Y
159					
160	Fixed Meeting Rail:				
161	Fixed Meeting Rail, w/187"x210" Weatherstrip Gray, 240" - Almond	V101600A	V-1016		Y
162	Fixed Meeting Rail, w/187"x210" Weatherstrip White, 240" - White	V101600C	V-1016		Y
163	Fixed Meeting Rail, w/187"x210" Weatherstrip Gray, 240" - Clay	V101600D	V-1016		Y
170	Fixed Meeting Rail, w/ 187"x210" Weatherstrip White, 240" - Bronze (Ext), White (Int)	V101600B	V-1016		Y
171	Fixed Meeting Rail, w/ 187"x210" Weatherstrip White, 240" - Black (Ext), White (Int)	V101600L	V-1016		Y
172					
173	Attachment Screws #8 x 2 1/2" Vinyl HLD Truss HD 410	FS000270			



Report #: 1820.05-106-12

Date: 4/12/2019

By: M. Stremmel

	B	C	D	E	F
1	1620 Single Hung - Bill of Materials	Last update: 03/20/19			
2					
3	Description	MIWD Part No.	Vendor Part No.	Rev.	CAD
174	Fixed Meeting Rail Aluminum Reinforcement	M2343000	M-2343		Y
176					
177					
178	Adjustable Keeper, Face Mount - Almond	K000200A	8383.104	-	Y
179	Adjustable Keeper, Face Mount - White	K000200C	8383.008	-	Y
180	Adjustable Keeper, Face Mount - Clay	K000200D	8383.304	-	Y
182					
183	KEEPER SCREW,#6,8-18X3/4",PFH,STL,ZINC,PLTD,S-DRL,SCRW,HDS, - Almond	FS00360A	-	-	N
184	KEEPER SCREW,#6,8-18X3/4",PFH,STL,ZINC,PLTD,S-DRL,SCRW,HDS, - White	FS00360C	-	-	N
186	KEEPER SCREW,#6,8-18X3/4",PFH,STL,ZINC,PLTD,S-DRL,SCRW,HDS, - Clay	FS00360D	-	-	N
187					
188	Setting Blocks 1/8" x 7/8" x 7/8" for 7/8" and 3/4" IG's thickness (Standard)	MS100050			no
189	Setting Block, 1/16" x 7/8" x 7/8" (If 1/8" Thick Is too Tight)	MS100030	G062028K780GD	-	N
190	Setting Block, 3/32" x 7/8" x 7/8" (If 1/8" Thick Is Too Loose)	MS100040			N
191					
192	Glazing		Pecora 896		
193					
194	Sealant	?		-	no
195					
196	Top Glass : I.G. Unit, Thickness and Make-Up varies with option selected			-	no
197	Glazing Bead, 7/8" IG, 192" - Almond	V067600A	V-676	D	Y
198	Glazing Bead, 7/8" IG, 192" - White	V067600C	V-676	D	Y
199	Glazing Bead, 7/8" IG, 192" - Clay	V090400D	V-676	-	Y
200	Glazing Bead, 7/8" IG, 192" - Bronze Ext Lami on White	V067601B	V-676	D	Y
201	Glazing Bead, 7/8" IG, 192" - Black Ext Lami on White	V067601L	V-676	-	Y
202					
203					
204	Bottom Sash (Impact Sash):				
205	Bottom Sash, Top Rail, w/ 187"x240" Weatherstrip Gray, 192" - Almond	V067500A	V-675	F	Y
206	Bottom Sash, Top Rail, w/ 187"x240" Weatherstrip White, 192" - White	V067500C	V-675	F	Y
207	Bottom Sash, Top Rail, w/ 187"x240" Weatherstrip Gray, 192" - Clay	V067500D	V-675	F	Y
214	Bottom Sash, Top Rail, w/ 187"x240" Weatherstrip Gray, 192" - Bronze (Ext), White (Int)	V067503B	V-675	F	Y
215	Bottom Sash, Top Rail, w/ 187"x240" Weatherstrip Gray, 192" - Black (Ext), White (Int)	V067503L	V-675	F	Y
216					
217	Lock Rail Liner - (Aluminum) Various lengths and part no. - part no. for 14" (Primary Reinf)	M2115000	M-2115	-	yes
218					
221					
222	Bottom Sash, Bottom Rail, 192" - Almond	V067200A	V-672	D	Y
223	Bottom Sash, Bottom Rail, 192" - White	V067200C	V-672	D	Y
224	Bottom Sash, Bottom Rail, 192" - Clay	V067200D	V-672	D	Y
231	Bottom Sash, Bottom Rail, 192" - Bronze (Ext), White (Int)	V067203B	V-672	D	Y
232	Bottom Sash, Bottom Rail, 192" - Black (Ext), White (Int)	V067203L	V-672	D	Y
233					
234	Bottom Sash, Bottom Rail, Interior Bulb Seal, .187 x .350 - Almond	MS20002A	32087111891500	-	N
235	Bottom Sash, Bottom Rail, Interior Bulb Seal, .187 x .350 - White	MS20002C	32087112191500	-	N
236	Bottom Sash, Bottom Rail, Interior Bulb Seal, .187 x .350 - Clay	MS20002D	G32087D	-	N
237					
238	Bottom Sash, Bottom Rail, Exterior Offset Bulb Seal, .187 x .500 - Almond	MS30000A	32324	-	N
239	Bottom Sash, Bottom Rail, Exterior Offset Bulb Seal, .187 x .500 - White	MS30000C	32324	-	N
240	Bottom Sash, Bottom Rail, Exterior Offset Bulb Seal, .187 x .500 - Black	MS30000L	32324	-	N
241	Bottom Sash, Bottom Rail, Exterior Offset Bulb Seal, .187 x .500 - Clay	MS30000D	32324	-	N
242					
243	Bottom Sash, Stile, w/ 187"x.240" Weatherstrip Gray, 192" - Almond	V067000A	V-670	B	Y
244	Bottom Sash, Stile, w/ 187"x.240" Weatherstrip White, 192" - White	V067000C	V-670	B	Y
245	Bottom Sash, Stile, w/ 187"x.240" Weatherstrip Gray, 192" - Clay	V067000D	V-670	B	Y
252	Bottom Sash, Stile, w/ 187"x.240" Weatherstrip Gray, 192"- Bronze (Ext), White (Int)	V067002B	V-670	B	Y
253	Bottom Sash, Stile, w/ 187"x240" Weatherstrip Gray, 192" - Black (Ext), White (Int)	V067003L	V-670	B	Y
254					
255	Stile Reinforcement - (Aluminum) Various lengths and part no. - part no. for 14" (Primary Reinf)	M2266000	M-2266	-	yes
256	Sash Stile Reinforcement Screw #8 PFH 1"	FS005750			
257					
258	Two Tone Pyle Dust Plug, 5/8", Kiss Cut - White / Gray	WS400000		-	N
259					
260	Lock, IMPACT:				
261	Cam Lock, (Cast Zinc) Left - Almond	LL00074A		-	N
262	Cam Lock, (Cast Zinc) Left - White	LL00074C		-	N
263	Cam Lock, (Cast Zinc) Left - Clay	LL00074D		-	N
264	Cam Lock, (Cast Zinc) Right - Almond	LR00074A		-	N
265	Cam Lock, (Cast Zinc) Right - White	LR00074C		-	N
266	Cam Lock, (Cast Zinc) Right - Clay	LR00074D		-	N
267					
268	CAMLOCK SCREW,#6,8-18X7/8",PFH,STL,ZINC,PLTD,S-DRL,150-PT,HDS, - Almond	FS00350A	-	-	Y
269	CAMLOCK SCREW,#6,8-18X7/8",PFH,STL,ZINC,PLTD,S-DRL,150-PT,HDS, - White	FS00350C	-	-	Y
270	CAMLOCK SCREW,#6,8-18X7/8",PFH,STL,ZINC,PLTD,S-DRL,150-PT,HDS, - Clay	FS00350D	-	-	Y
271					
272	Aluminum Reinforcement, B, Tilt-Latch, 5", Bottom Sash, Top Rail, 150"	M2116000	M-2116	A	Y
273					
274	Tilt-Latch Assembly, High-Performance, Universal - Almond	TL00003A	75005-999-KH4	-	N
275	Tilt-Latch Assembly, High-Performance, Universal - White	TL00003C	75005-999-KH1	-	N
276	Tilt-Latch Assembly, High-Performance, Universal - Clay	TL00003D	75005-999-	-	N
277					
278					
279	Tilt-Latch Screw, #8 x 1" PFH, #6 Head, SMS, A, U48, 410 SS - Almond	FS00419A	-	-	N
280	Tilt-Latch Screw, #8 x 1" PFH, #6 Head, SMS, A, U48, 410 SS - White	FS00419C	-	-	N
281	Tilt-Latch Screw, #8 x 1" PFH, #6 Head, SMS, A, U48, 410 SS - Clay	FS00419D	-	-	N
282					
283	Pivot Bar, Locking Head, Offset, Zinc	HD100046		-	Y
284					
285	Pivot Bar Screw, #6-32 5/16" PPH Washer Head Type F	FS000080		-	N
286					
287	Glazing	-	896 TBS	-	N
288					
289	Setting Blocks 1/8" x 7/8" x 7/8" for 7/8" and 3/4" IG's thickness (Standard)	MS100050			no
290	Setting Block, 1/16" x 7/8" x 7/8" (If 1/8" Thick Is too Tight)	MS100030	G062028K780GD	-	N
291	Setting Block, 3/32" x 7/8" x 7/8" (If 1/8" Thick Is Too Loose)	MS100040			N
292					
293	Glass Panel, 7/8" Overall IG, Make-up Varies with Options	-	-	-	N
294					
295					
296	Glazing Bead, 7/8" IG, 192" - Almond	V067600A	V-676	D	Y
297	Glazing Bead, 7/8" IG, 192" - White	V067600C	V-676	D	Y
298	Glazing Bead, 7/8" IG, 192" - Clay	V090400D	V-676	-	Y
299	Glazing Bead, 7/8" IG, 192" - Bronze Ext Lami on White	V067601B	V-676	D	Y
300	Glazing Bead, 7/8" IG, 192" - Black Ext Lami on White	V067601L	V-676	-	Y
301					



Report #: 1820.05-106-12

Date: 4/12/2019

By: M. Stremmel

	B	C	D	E	F
1	1620 Single Hung - Bill of Materials	Last update: 03/20/19			
2					
3	Description	MIWD Part No.	Vendor Part No.	Rev.	CAD
302	Roll Form Half Screen (Standard):				
303	Screen Frame - White	SC30003C	A-105-6C		Y
304	Screen Frame - Almond	SC30003A	A-105-6A		Y
305	Screen Frame - Bronze	SC30003B	A-105-6B		Y
306	Screen Frame - Clay	SC30003D	A-105-6B		Y
307	Screen Frame - Black	SC30003L	A-105-6B		Y
308					
309	Screen Corner Key Right Dimple - White	IM10011M	AI205MOCMPR_200205066501		Y
310	Screen Corner Key Right Dimple - Almond	IM10007K	AI205KDMPR		Y
311	Screen Corner Key Right Dimple - Dark Bronze	IM10011B	AI205DBDMPL		Y
312	Screen Corner Key Right Dimple - Black	IM10011L			Y
313	Screen Corner Key Right Dimple - Clay	IM10011D	AI205LWBDMPR		Y
314					
315	Screen Corner Key Left Dimple - White	IM10010M	AI205MOCDMPL_200205066501		Y
316	Screen Corner Key Left Dimple - Almond	IM10006K	AI205KDMPL		Y
317	Screen Corner Key Left Dimple - Dark Bronze	IM10010B	AI205DBDMPL		Y
318	Screen Corner Key Left Dimple - Black	IM10010L			Y
319	Screen Corner Key Left Dimple - Clay	IM10010D	AI205LWBDMPL		Y
320					
321	Screen Corner Key - White	IM10009M	AI205PMOC		Y
322	Screen Corner Key - Almond	IM10010K	AI205PK		Y
323	Screen Corner Key - Dark Bronze	IM10009B	AI205P-DB		Y
324	Screen Corner Key - Black	IM10009L			Y
325	Screen Corner Key - Clay	IM10009D	AI205P-LWB		Y
326					
327	Finger Pull - Clear	IM100830	AI34270D00C32		
328					
329	Leaf Spring, Stainless Steel, 3"	HD002380	402A402G402	-	N
330					
331	Screen Mesh	Varies	Varies	-	N
332					
333	Screen Spline, Solid Foam, 0.140" Dia	SC60140L	1406000-1-SP	-	N
334					
335	Screen Warning Label	LB000003	GX7166	-	N
336					
337	Grids:				
338	Grid, 5/8" Flat, 152" - Almond	GD22014A	-	-	N
339	Grid, 5/8" Flat, 152" - White	GD22014C	-	-	N
348	Grid, 5/8" Flat, 152" - Clay	GD22014D	-	-	N
349	Grid, 5/8" Flat, Two-Tone, 152" - Bronze (Ext), White (Int)	GD20423C	31658	-	N
350	Grid, 5/8" Flat, Two-Tone, 152" - Black (Ext), White (Int)	GD20423L			
351					
352	Clip, 5/8" Flat, Grid, Concealed, Cross	IM200000	G1165	-	Y
353					
354	Clip, Grid Lock, End, 3/16" x 5/8" x 1/2"	IM20009G	316-50GL-580	-	N
355	Clip, Grid Lock, End, 3/16" x 5/8" x 1/4" (Triple)	HD00607L	40025GL580	-	N
356	Clip, Grid Lock, End, 3/16" x 5/8" x 3/16" (Triple)	HD00608L	40018GL580	-	N
357	Pin, Grid, End, 3/16" x 5/8" x 11/16" (7/8" I.G.)	HD00170G	316-62GL-580	-	N
358					
359					
360	Clip, Grid Lock, End, 3/16" x 13/16" x 7/16"	HD00265G	330-43GL-340	-	N
361	Clip, Grid Lock, End, 3/16" x 3/4" x 1/4" (Triple)	HD00605L	43025GL340	-	N
362	Pin, Grid, End, 3/16" x 3/4" or 3/16" x 13/16" (7/8" I.G.)	HD00161G	33062GL340	-	N
363					
364	Grid Internal Spacer (GBG) 3/16" x 3/4" .024 Flat 152" - Almond	GD22013A			N
365	Grid Internal Spacer (GBG) 3/16" x 3/4" .024 Flat 152" - White	GD22013C			N
366	Grid Internal Spacer (GBG) 3/16" x 3/4" .024 Flat 152" - Clay	GD22013D			N
367	Grid Internal Spacer (GBG) 3/16" x 3/4" .024 Flat 152" - Bronze	GD22011B			N
368	Grid Internal Spacer (GBG) 3/16" x 3/4" .024 Flat 152" - Black (NOT SET UP YET) Looking to Use Bronze G	GD22011L			N
369					
370	Grid, 5.5mm x 11/16" Contour, 152" - Almond	GD21000A	EDA5.518T-05A	-	N
371	Grid, 5.5mm x 11/16" Contour, 152" - White	GD21000C	EDA5.518AW-05A	-	N
372	Grid, 5.5mm x 11/16" Contour, 152" - Clay	GD21000D		-	N
380	Grid, 5.5mm x 11/16" Contour, Laminate, 152" - Bronze (Ext), White (Int)	GD21000Q	EDA5.518TT	-	N
381	Grid, 5.5mm x 11/16" Contour, Laminate, 152" - Black (Ext), White (Int)	GDP210CL	EDA5.518TT	-	N
382					
383	Muntin, Joiner, Fish Mouth, Part A, 5.5mm x 11/16"	HD402060	DDE5.5AFMA-1	-	N
384	Muntin, Joiner, Fish Mouth, Part B, 5.5mm x 11/16"	HD402061	DDE5.5AFMB-1	-	N
385					
386	Clip, Grid Lock, End, 5.5mm x 18mm x 1/2"	HD001962	380-50GL-180	-	N
387					
388	"OG" Sculptured Grid 1/8" x 1 1/8" - Almond	GD22070A			N
389	"OG" Sculptured Grid 1/8" x 1 1/8" - White	GD22070C			N
390	"OG" Sculptured Grid 1/8" x 1 1/8" - Clay	GD22070D			N
391	"OG" Sculptured Grid 1/8" x 1 1/8" - Bronze	GD22070B			N
392	"OG" Sculptured Grid 1/8" x 1 1/8" - Black	GD22070L			N
393					
394	Miscellaneous Accessories:				
395					
396	Snap-In J-Channel, 192" - Almond	V070400A	V-704	A	Y
397	Snap-In J-Channel, 192" - White	V070400C	V-704	A	Y
398	Snap-In J-Channel, 192" - Clay	V070400D	V-704	A	Y
399					
400	Head Expander, 1", 192" - Almond	V000100A	V-001	-	Y
401	Head Expander, 1", 192" - White	V000100C	V-001	-	Y
402	Head Expander, 1", 192" - Clay	V000100D	V-001	-	Y
409	Head Expander, 1", 192" - Bronze (Ext), White (Int)	V000105B	V-001	-	Y
410	Head Expander, 1", 192" - Black (Ext), White (Int)	V000100L	V-001	-	Y
411					
412	Sill Angle, 192" - Almond	V727602A	V-7276	-	Y
413	Sill Angle, 192" - White	V727602C	V-7276	-	Y
414	Sill Angle, 192" - Bronze (Ext), White (Int)	V027600B	V-7276	-	Y
415	Sill Angle, 192" - Clay	V727602D	V-7276	-	Y
416	Sill Angle, 192" - Black (Ext), White (Int)	V027600L	V-7276	-	Y
417					
418	Mullions:				
419	Structural 1-1/8" Mullion:				
420	M2285 1-1/8" Structural Mullion 188" - Almond	M228503A			Y
421	M2285 1-1/8" Structural Mullion 188" - White	M228503C			Y
422	M2285 1-1/8" Structural Mullion 188" - Clay	M228503D			Y
423	M2285 1-1/8" Structural Mullion 188" - Bronze (Painted)	M228503B			Y
424	M2285 1-1/8" Structural Mullion 188" - Black (Painted)	M228503L			Y
425					
426	M-2304 Interior Mullion (Mill)	M2286000		-	
427	#10 x 3/4" PPH Self Taping Screw	FS001700			
428	Interior Mullion Cover White	V093000C	V-930	-	



Report #: 1820.05-106-12

Date: 4/12/2019

By: M. Stremmel

	B	C	D	E	F
1	1620 Single Hung - Bill of Materials	Last update: 03/20/19			
2					
3	Description	MIWD Part No.	Vendor Part No.	Rev.	CAD
429	Interior Mullion Cover Almond	V093000A	V-930	-	
430	Interior Mullion Cover Clay	V093000D	V-930	-	
431					
432	Vertical Mullion Clip (Aluminum)	HD004060		-	
433	Vertical Mullion Clip For Masonry (Aluminum)	HD004070		-	
434	Horizontal Mullion Clip (Stamped Steel)	MT000022		-	
435					
436	End Cap Block Off	HD402040		-	
437	End Cap For Mull Clip	HD402030		-	
438	#8 x 3/8" PFH Sheet Metal Screw	FS000660		-	
439					
440	3" x 3" Butal sealing pad	MS001530			
441	End Cap Fin w J Channel (White)	IM20023C			
442	End Cap Fin w J Channel (Almond)	IM20023A			
443	End Cap Fin w J Channel (Clay)	IM20023D			
444					
445	Flange Mullion:				
446	Mull, HP, Aluminum, Vertical / Horizontal, 180" - Almond	M230000A	M-2300	-	Y
447	Mull, HP, Aluminum, Vertical / Horizontal, 180" - White	M230000C	M-2300	-	Y
448	Mull, HP, Aluminum, Vertical / Horizontal, 180" - Clay	M230000D	M-2300	-	Y
449	Mull, HP, Aluminum, Vertical / Horizontal, 180" - Bronze Ext Lami / White Int	M230000B	M-2300	-	Y
450	Mull, HP, Aluminum, Vertical / Horizontal, 180" - Black Ext Lami / White Int	M230000L	M-2300	-	Y
451					
452	Mull, HP, Aluminum, Horizontal, Twin / Triple, 180" - Almond	M230100A	M-2301	-	Y
453	Mull, HP, Aluminum, Horizontal, Twin / Triple, 180" - White	M230100C	M-2301	-	Y
454	Mull, HP, Aluminum, Horizontal, Twin / Triple, 180" - Clay	M230100C	M-2301	-	Y
455	Mull, HP, Aluminum, Horizontal, Twin / Triple, 180" - Bronze Ext Lami / White Int	M230100B	M-2301	-	Y
456	Mull, HP, Aluminum, Horizontal, Twin / Triple, 180" - Black Ext Lami / White Int	M230100L	M-2301	-	Y
457					
458	Drip Cap, Fin, 192" - Almond	M228105A	M-2281	A	Y
459	Drip Cap, Fin, 192" - White	M228105C	M-2281	A	Y
460	Drip Cap, Fin, 192" - Clay	M228105D	M-2281	A	Y
461	Drip Cap, Fin, 192" - Dark Bronze	M228105B	M-2281	A	Y
462	Drip Cap, Fin, 192" - Black	M228105L	M-2281	A	Y
463					
464	Drip Cap, Finless, 183" - Almond	M164300A	M1643A183	A	Y
465	Drip Cap, Finless, 183" - White	M164300C	M1643C183	A	Y
466	Drip Cap, Finless, 183" - Clay	M164300D	M1643C183	A	Y
467	Drip Cap, Finless, 183" - Dark Bronze	M164301B	M1643A183	A	Y
468	Drip Cap, Finless, 183" - Black	M164301L	M1643C183	A	Y
469					
470					
471	Optional Window Opening Control Device (W.O.C.D.):				
472	Window Opening Control Device, Snap-In - Almond	HD40130A	1761VBG	-	N
473	Window Opening Control Device, Snap-In - White	HD40130C	1761JEW	-	N
474	Window Opening Control Device, Snap-In - Clay	HD40130D	1761	-	N
475					
476	Packaging:				
477	Label, Window Warning	LB000003	GX7166	-	N
478					
479	Label, NFRC, 4" x 8", Thermal Transfer	LB000006	9916502G10317	-	N
480					
481					
482	Label, Product (Misc.), 3" x 6", Shipping	LB000119	9916360	-	N
483					
484	Label, MIWD, 8 1/2" x 11", DH/NC, Backer	LB000700	29169	-	N
485	Label, Window World, 8 1/2" x 11", Care and Cleaning on Back	LB000740	31559	-	N
486					
487					
488	Package Material, Honeycomb Strip, Small, 48" x 3" x 1", 1/2" Cell, Cookie Cut, 6"	PK000606	-	-	N
489	Package Material, Honeycomb Strip, Large, 4" x 40" x 3-1/2", PSA, 1-Side	PK000008	BCB1894	-	N
490					
491					

	Molimo™
	Architectural Product Testing
	Report #: 1820.05-106-12
	Date: 4/12/2019
By: M. Stremmel	

VINYL EXTRUSION CRITICAL DIMENSION SHEET

1	2	3	4	5	6	7	8	9	10	11	12
.119	.197	.638	90 DEG	1.804	.566	90 DEG	90 DEG	.122	.806	.685	.298
+0.010 -0.010	+0.010 -0.010	+0.015 -0.015	+5 DEG -5 DEG	+0.015 -0.015	+0.010 -0.010	+5 DEG -5 DEG	+5 DEG -5 DEG	+0.015 -0.010	+0.025 -0.020	+0.025 -0.015	+0.015 -0.025
13	14	15	16	17	18	19	20	21	22	23	24
.385											
+0.020 -0.010											

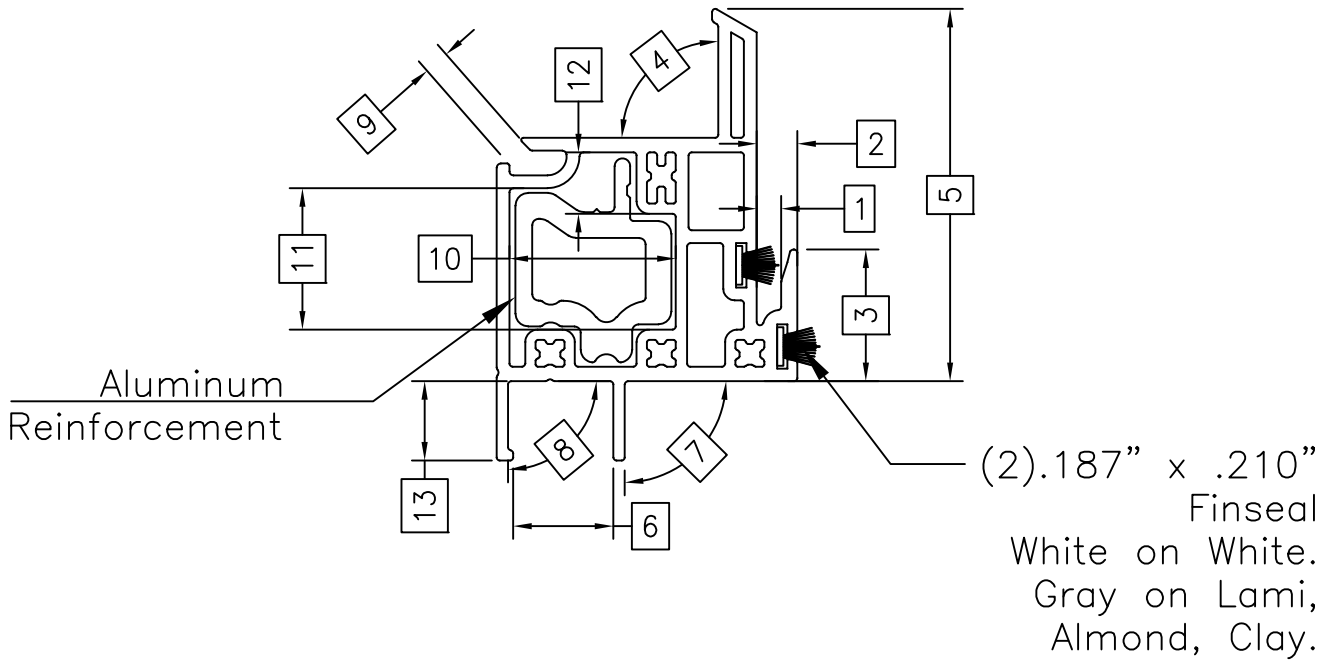

Fixed Meeting Rail=V-1016

NOTES: TYPICAL WALL THICKNESS: .062-.070+.005/-0.005
 SQUARENESS CRITICAL - USE GAUGE.
 BOW TOLERANCE - 1/2" ON 2 - 16' PIECES.

Molimo[™]
 Architectural Product Testing
 Report #: 1820.05-106-12
 Date: 4/12/2019
 By: M. Stremmel

MiND MI WINDOWS AND DOORS
 650 WEST MARKET STREET GRATZ, PA 17030-0370

DESCRIPTION: 1620 Single Hung Fixed Meeting Rail
 1630 Single Slide Fixed Meeting Rail

DFTM: HAL DATE: 6/9/15 SCALE: 1 : 1

LTR	REVISIONS	DATE	BY	PART #: V-1016	DRAWING #: CD-000025
-----	-----------	------	----	----------------	----------------------

VINYL EXTRUSION CRITICAL DIMENSION SHEET

1	2	3	4	5	6	7	8	9	10	11	12
1.260	1.750	0.067	0.625	0.216	0.340	0.120	1.001	0.210	0.125	1.460	0.225
+0.010 -0.010	+0.015 -0.015	+0.005 -0.005	+0.010 -0.010	+0.010 -0.010	+0.010 -0.010	+0.010 -0.010	+0.010 -0.010	+0.010 -0.010	+0.010 -0.010	+0.010 -0.010	+0.010 -0.010
13	14	15	16	17	18	19	20	21	22	23	24
0.308	0.246	0.030	.946								
+0.015 -0.015	+0.010 -0.010	+0.005 -0.005	+0.010 -0.010								

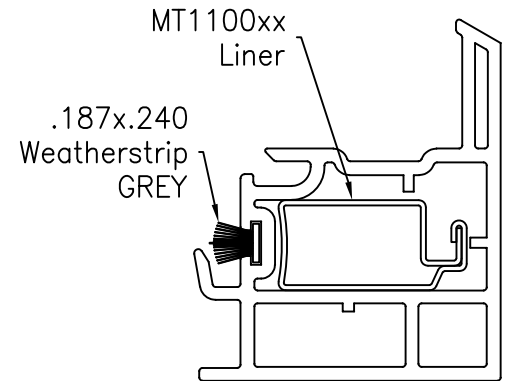
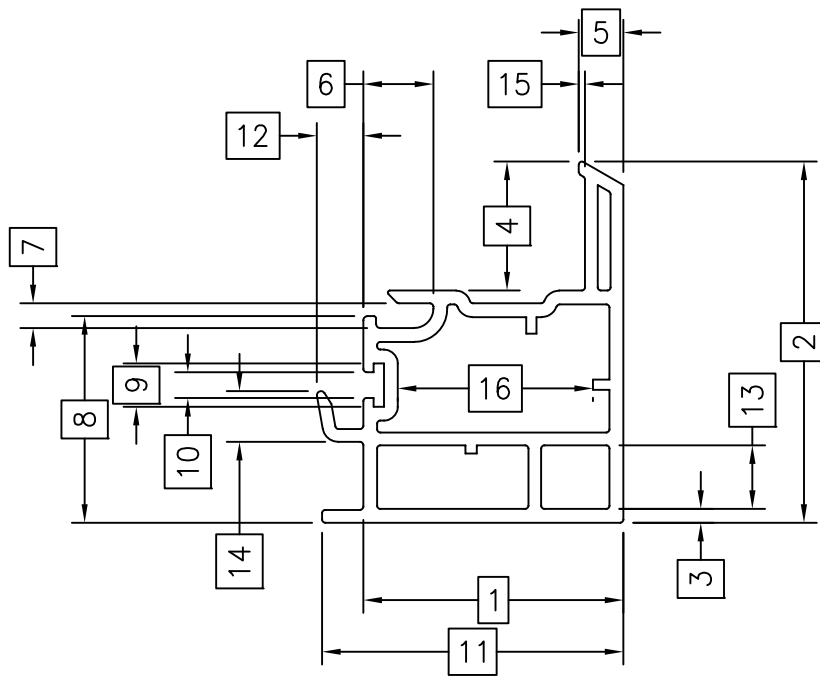

Molimo
Architectural Product Testing

Report #: 1820.05-106-12

Date: 4/12/2019

By: M. Stremmel

NOTES: Squareness 90° ±1° from glazing leg to latch cover side.
Bow tolerance - 2" on center of (2) 16' pieces.

TYPICAL WALL THICKNESS: 0.067 ±0.005

B	Added Dim 16			10-17-18	VMR	DESCRIPTION: 1650 Double Hung Bottom Sash Lock Rail					
A	Changed all colors to use Grey pile.			2/6/17	VR	DESCRIPTION: 1650 Double Hung Bottom Sash Lock Rail					
	Updated title block and uploaded to Vault.			08/26/16	BRS	DFTM: VMR	DATE: 04/23/01	SCALE: 1:1			
LTR	REVISIONS			DATE	BY	PART #: V-675			DRAWING #: CD-000080		

MI MI WINDOWS AND DOORS, LLC.
650 WEST MARKET STREET GRATZ, PA 17030-0370

VINYL EXTRUSION CRITICAL DIMENSION SHEET

1	2	3	4	5	6	7	8	9	10	11	12
1.260	1.750	0.444	0.625	0.216	0.340	0.120	1.001	0.210	0.125	0.320	90°
+0.010 -0.010	+0.015 -0.015	+0.010 -0.010	+0.010 -0.010	+0.010 -0.010	+0.010 -0.010	+0.010 -0.010	+0.010 -0.010	+0.010 -0.010	+0.010 -0.010	+0.015 -0.015	+1° -1°
13	14	15	16	17	18	19	20	21	22	23	24
0.067	0.030										
+0.005 -0.005	+0.005 -0.005										

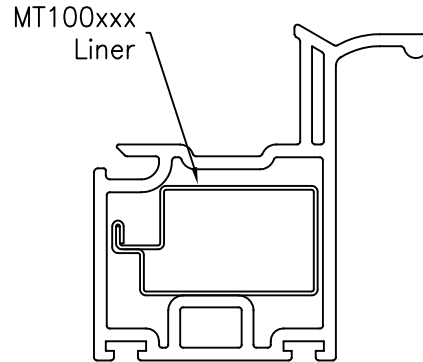
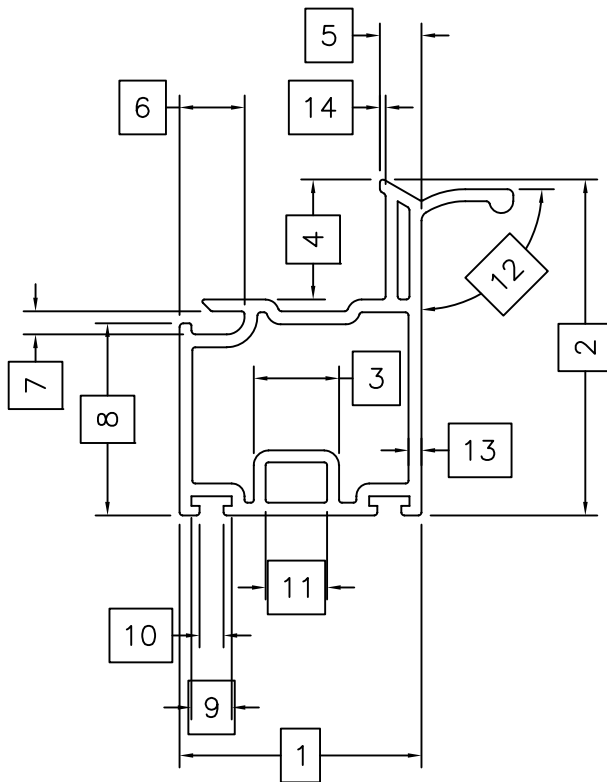

	Molimo [™] Architectural Product Testing
Report #:	1820.05-106-12
Date:	4/12/2019
By:	M. Stremmel

NOTES: Squareness 90° ±1° from glazing leg to latch cover side.
Bow tolerance - 2" on center of (2) 16' pieces.

TYPICAL WALL THICKNESS: 0.067 ±0.005



MI WINDOWS AND DOORS, LLC.
650 WEST MARKET STREET GRATZ, PA 17030-0370

DESCRIPTION: 1650 Double Hung
Bottom Sash Lift Rail

DFTM: VMR

DATE: 04/23/01

SCALE: 1:1

Updated title block and uploaded to Vault.

08/26/16

BRS

PART #: V-672

DRAWING #: CD-000077

LTR

REVISIONS

DATE

BY

VINYL EXTRUSION CRITICAL DIMENSION SHEET

1	2	3	4	5	6	7	8	9	10	11	12
1.260	1.750	0.067	0.625	0.216	0.340	0.120	1.001	0.210	0.125	0.030	
+0.010 -0.010	+0.015 -0.015	+0.005 -0.005	+0.010 -0.010	+0.010 -0.010	+0.010 -0.010	+0.010 -0.010	+0.010 -0.010	+0.010 -0.010	+0.010 -0.010	+0.005 -0.005	
13	14	15	16	17	18	19	20	21	22	23	24

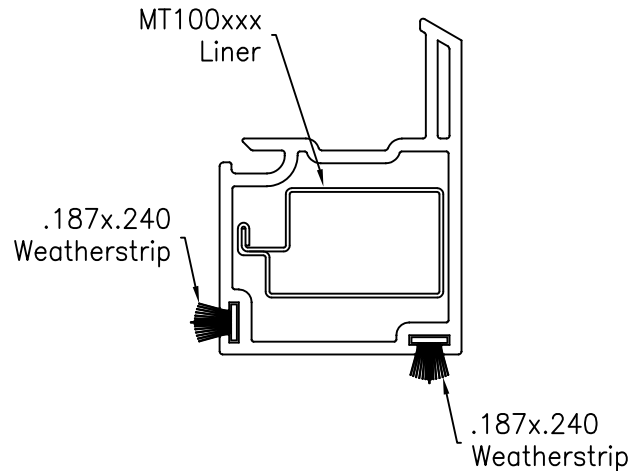
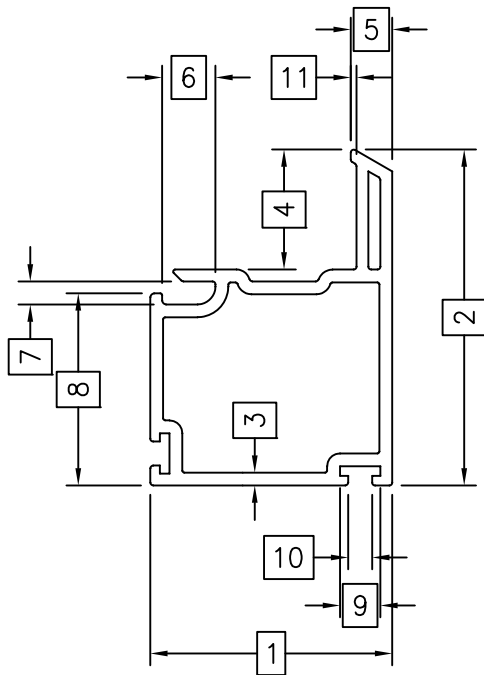

Molimo
Architectural Product Testing

Report #: 1820.05-106-12

Date: 4/12/2019

By: M. Stremmel

NOTES: Squareness 90° ±1° from glazing leg to latch cover side.
Bow tolerance - 2" on center of (2) 16' pieces.

TYPICAL WALL THICKNESS: 0.067 ±0.005

MI MI WINDOWS AND DOORS, LLC.
650 WEST MARKET STREET GRATZ, PA 17030-0370

DESCRIPTION: 1650 Double Hung
Bottom Sash Stile

DFTM: VMR DATE: 04/23/01 SCALE: 1:1

PART #: V-670 DRAWING #: CD-000075

Updated title block and uploaded to Vault.	08/26/16	BRS
LTR	REVISIONS	DATE BY

VINYL EXTRUSION CRITICAL DIMENSION SHEET

1	2	3	4	5	6	7	8	9	10	11	12
0.135	0.750	0.316	0.580	0.040							
+0.005 -0.005	+0.005 -0.005	+0.005 -0.005	-0.000 +0.010	+0.005 -0.005							
13	14	15	16	17	18	19	20	21	22	23	24

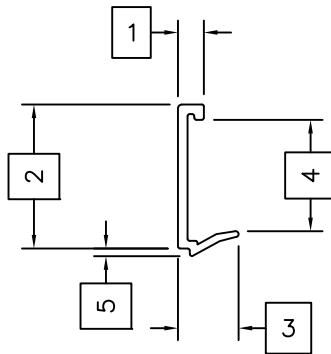

Molimo™
Architectural Product Testing

Report #: 1820.05-106-12

Date: 4/12/2019

By: M. Stremmel

NOTES:

TYPICAL WALL THICKNESS: 0.050 ±0.003

					<b style="font-size: 1.2em; vertical-align: middle;">MI	MI WINDOWS AND DOORS, LLC. <small>650 WEST MARKET STREET GRATZ, PA 17030-0370</small>
					DESCRIPTION: Glazing Bead 7/8" I.G.	
					DFTM: VMR	DATE: 04/23/01
					SCALE: 1:1	
	Updated title block and uploaded to Vault.		09/08/16	BRS		
LTR	REVISIONS		DATE	BY	PART #: V-676	DRAWING #: CD-000129

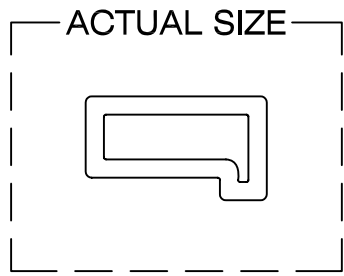
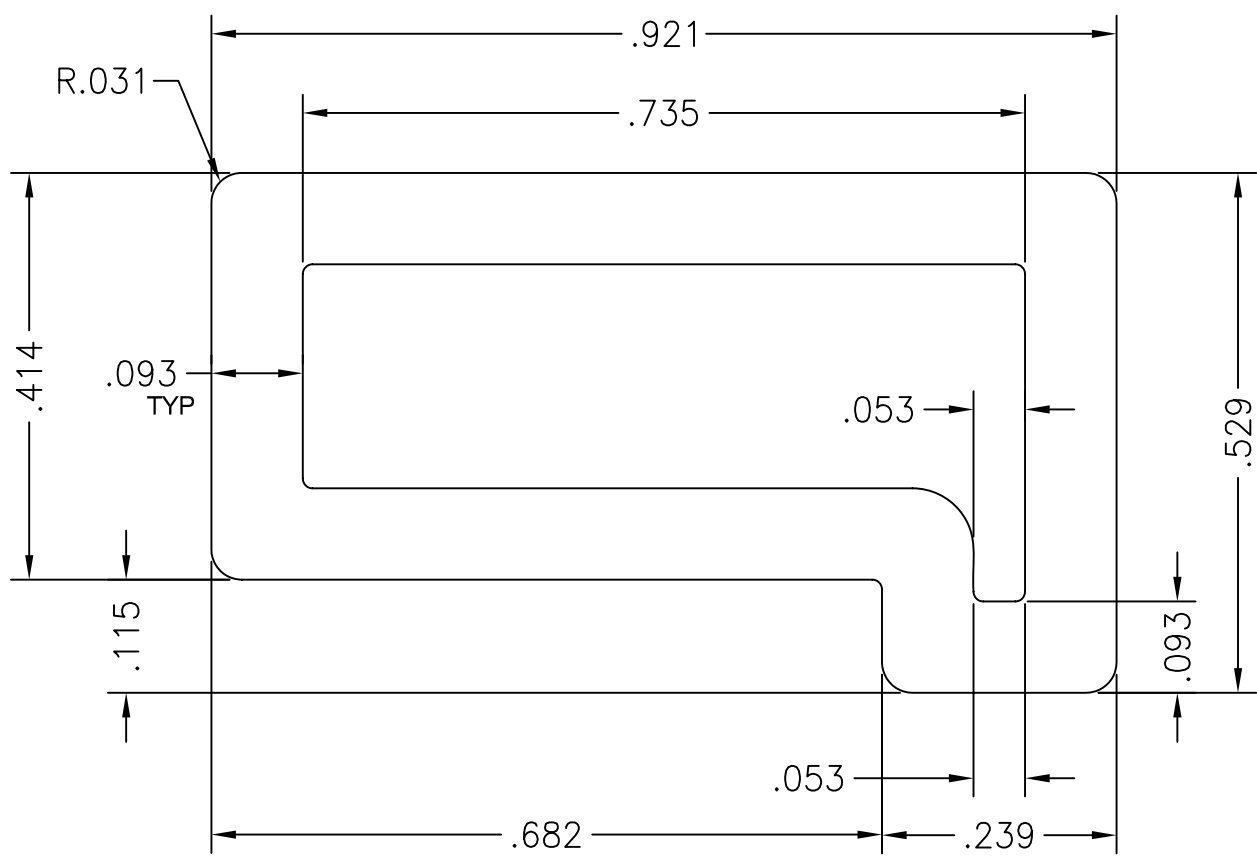

Molimo™
Architectural Product Testing

Report #: 1820.05-106-12

Date: 4/12/2019

By: M. Stremmel

BREAK UNSPECIFIED SHARP CORNERS: R.010



MI WINDOWS AND DOORS
650 WEST MARKET STREET • GRATZ, PA • 17030-0370

The information, design or data shown on this document or electronic media is the exclusive property of MI WINDOWS AND DOORS, INC. It is considered confidential and proprietary and is made available for limited use only. Its use or reproduction without the expressed written consent of MI WINDOWS AND DOORS, INC., is prohibited.

TITLE Series 3540 'Impact' Single Hung Lock Rail Reinforcement-A

DFTM. BRS		DATE	SCALE	CUSTOMER NAME		
-		6/19/06	5:1	-		
AREA		PERIM.	EXT. PERIM.	WT./FT.	FACTOR	
0.234		2.829	4.937	0.281	-	
CIRCLE SIZE		CLASS	ALLOY/TEMPOR		FINISH	
1-2		HOLLOW	6063-T5		-	
LTR	DESCRIPTION	BY	DATE	PLANT LOC.	THERMAL CAVITY	DWG/PART NO.
	REVISIONS			MILLERSBURG	-	M-2115
						REV. -

