

Product Evaluation

RC682 | 1221

Engineering Services Program

The following product has been evaluated for compliance with the wind loads specified in the International Residential Code (IRC) and the International Building Code (IBC).

This product evaluation is not an endorsement of this product or a recommendation that this product be used. The Texas Department of Insurance has not authorized the use of any information contained in the product evaluation for advertising, or other commercial or promotional purpose.

This product evaluation is intended for use by those individuals who are following the design wind load criteria in Chapter 3 of the IRC and Section 1609 of the IBC. The design loads determined for the building or structure shall not exceed the design load rating specified for the products shown in the limitations section of this product evaluation. This product evaluation does not relieve a Texas licensed engineer of his responsibilities as outlined in the Texas Insurance Code, the Texas Administrative Code, and the Texas Engineering Practice Act.

For more information, contact TDI Engineering Services Program at (800) 248-6032.

Evaluation ID: RC-682

Effective Date: December 1, 2021

Re-evaluation Date: December 2025

Product Name: Extruded Interlocking Concrete Roof Tiles

Manufacturer: Presajet SAPI de CV / Crown Roof Tiles
Carretera a Villa de Garcia Km 11.8
Garcia, Nuevo Leon, MX CP 66001
(817) 225-6112

General Description:

This evaluation report covers extruded concrete Iberia, Mediterranean, Tuscany, and Windsor roof tile that are interlocking. The interlocking tiles have interlocking ribs on the longitudinal edges of the tiles. The interlocking ribs restrict lateral movement and provide a water stop. The tiles are available in a variety of colors.

Installation: Install the roof tiles in compliance with this product evaluation report and the manufacturer's installation instructions as referenced in the "*Florida High Wind Concrete and Clay Tile Installation Manual*," 6th Edition (FRSA-TRI Manual).

Mechanical Attachment: Install the roof tiles specified in this evaluation report mechanically with fasteners using one of the following attachment systems.

1. Installation using a 1 x 2 wood batten with one (1) corrosion resistant No. 8 x 2-1/2" wood screw in the center nail hole on the tile. The No. 8 wood screw must be long enough to penetrate completely through the batten and completely through the roof sheathing.
2. Installation using a 1 x 2 wood batten with two (2) corrosion resistant No. 8 x 2-1/2" wood screws in the left two nail holes on the tile. The No. 8 wood screw must be long enough to penetrate completely through the batten and completely through the roof sheathing.
3. Installation using a 1 x 2 wood batten with two (2) 10d ring shank nails in the left two nail holes on the tile. The 10d ring shank nail must be long enough to penetrate completely through the batten and completely through the roof sheathing.

Adhesive Attachment: Roof tiles installed with adhesive is outside the scope of this evaluation report. Adhesive fastening systems must comply with ICC-ES AC152, **Acceptance Criteria for Adhesive Fastening of Concrete or Clay Roof Tiles**. Refer to the adhesive fastening system manufacturer product evaluation for the allowable aerodynamic uplift moment and the installation method to develop a resistance equal to or greater than the code required aerodynamic uplift moment. Installation of roof tiles using an adhesive fastening system must be done by technicians trained and having a current certification by the adhesive fastening system manufacturer.

Roof Tile Profile Classifications: Classify roof tile profiles as one of the following:

- **Flat/Low Profile:** Flat/Low profile tiles are tiles with a rise equal to or less than 1/2".
- **Medium Profile:** Medium profile tiles are tiles with a rise greater than 1/2" and a rise to width ratio of less than or equal to 1.5.
- **High/Barrel Profile:** High profile tiles are tiles having a rise to width ratio greater than 1-1/2.

Tile Weight: This evaluation report covers standard weight tiles. Lightweight tiles are outside of the scope of this evaluation report.

Roof Tile Designations, Profile Classifications, and Dimensions: Table 1 specifies the roof tile designations, profile classifications, and dimensions for the roof tiles that apply to this product evaluation report. A picture of each roof tile is shown in Figures 1, 2, 3, 4, 5 and 6.

Table 1: Roof Tile Designations, Profile Classifications, and Dimensions

Tile Designation	Profile Classification	Tile		
		Length (in.)	Width (in.)	Exposed (in.)
Iberia	Medium	17.25	13	12.125
Mediterranean	High	17.25	11.75	10.875
Tuscany	Flat/Low	17.25	13	11.75
Windsor Slate	Flat/Low	17.25	13	12.125
Windsor Shake				
Windsor Split Shake				

Installation and Limitations:

Roof Framing and Roof Deck: Roof framing members must comply with either the IRC or the IBC. Do not space the roof-framing members greater than 24" on center. A minimum 15/32" plywood or 5/8" OSB solidly sheathed roof deck is required. Fasten the roof deck to the roof framing members in compliance with either the IRC or the IBC to resist the required wind loads.

If the existing roof deck is a spaced board roof deck, then either remove the spaced boards or cover with minimum 15/32" plywood or 5/8 OSB. Install the plywood or OSB sheathing over the spaced boards in compliance with either the IRC or the IBC to resist the required wind loads.

Metal Drip Edge: Install a metal drip edge as specified in the manufacturer's installation instructions as referenced in the FRSA-TRI Manual.

Roof Underlayment:

- **2.5:12 Roof Slope to Under 4:12 Roof Slope:** Single-ply or multi-ply sealed underlayment system with sealed head laps and side laps. Install the underlayment as specified in either the IRC or the IBC and in the manufacturer's installation instructions as referenced in the FRSA-TRI Manual.
- **4:12 Roof Slope and Greater:** Minimum one layer of underlayment complying with ASTM D 226, Type II (No. 30 asphalt felt) or equivalent. Lap the underlayment a minimum of 2" at the head laps and a minimum of 6" at the side laps. Install the underlayment as specified in either the IRC or the IBC and in the manufacturer's installation instructions as referenced in the FRSA-TRI Manual.

Battens: Install the roof tiles over battens. Solidly sheath the roof deck with either minimum 15/32" plywood or 5/8" OSB. As a minimum, use a nominal 1x2 wood member for the battens. Space the battens to allow for a 3" or 4" headlap for the Iberia and Mediterranean depending on the installation and a 3" headlap for the Tuscany and Windsor. Fasten the battens to the roof deck with minimum 8d corrosion resistant common wire or box nails or equivalent size nail. Space the nails a maximum of 24" on center. As an alternative, fasten battens to the roof deck with No. 16-gauge by 7/16" crown by 1.5" long staples. Space the staples a maximum of 12" on center. Batten fasteners must be long enough to penetrate a minimum of 3/4" into or through the roof deck whichever is less. Separate batten ends a minimum of 1/2" every 4' to allow for drainage.

Roof Tile Installation: Install the roof tiles in accordance with the following guidelines:

- **Roof Slope Limitations:** Only install the roof tiles on buildings with a roof slope of 2-1/2:12 or greater. Table 3 specifies roof slope limitations. Note: Battens are required when the roof slope exceeds 7:12. At a roof slope greater than 24:12 from the horizontal, fasten the nose end of all tiles to the roof deck with a nose clip.
- **Moment of Resistance:** The overturning resistance (moment of resistance) due to wind of the roof tiles based on the installation method for the roof tiles is shown in Table 3.

- **Aerodynamic Uplift Moment:** The aerodynamic uplift moment for the roof tile is calculated using Equation 16-34 from the 2018 IBC. The aerodynamic uplift moment is calculated based on the mean roof height for the installation and the required wind speed and Exposure condition for the installation location using ASCE 7-16.
- **Permissible Tile Installation:** The roof tiles may be installed if the Moment of Resistance for the roof tile specified in this evaluation report is greater than the Aerodynamic Uplift Moment for the roof tile calculated for the structure location.
- **General:** The roof tiles and the underlayment system must be clean and dry at the time of their application.
- **Installation:** Install the roof tiles in compliance with this product evaluation report and the manufacturer's installation instructions as referenced in the FRSA-TRI Manual.

Lay out the roof tiles from the right to the left, starting at the right rake. Install the roof tiles with a 3" or 4" headlap for the Iberia and Mediterranean depending on the installation and a 3" headlap for the Tuscany and Windsor.

Roof Tile Fasteners: Mechanically fasten the roof tiles to the roof deck. The following fasteners are acceptable:

1. No. 8 course-threaded screw(s). Use a minimum 2-1/2" long, bugle head screws conforming to ANSI/ASME 8.18.6.1, having a nominal diameter of 0.335", a shank diameter of 0.131", and a screw thread diameter of 0.175". The screws must be long enough to penetrate completely through the roof sheathing.
2. 10d ring shank nails: The 10d ring shank nails had a shaft diameter of 0.139", a head diameter of 0.311", and a length of 3". The nails must be long enough to penetrate completely through the roof sheathing.

Roof Tile Fastener Locations: Figures 1, 2, 3, 4, 5 and 6 show the fastener hole locations for each roof tile.

Rake Tiles: Secure rake tiles to Southern Pine, Douglas Fir or Spruce-Pine-Fir lumber framing with either two minimum No. 8 screws or two minimum 10d ring shank nails. Use corrosion resistant fasteners long enough to penetrate the wood framing a minimum 3/4".

Hip and Ridge Tiles: Fasten the hip and ridge tiles to hip and ridge boards (Dimension lumber of sufficient height to support the hip and ridge tiles) in accordance with one of the following options:

1. Drill a 3/16" hole in the lower 1/3 of the starter tile. Use a fastener as specified in Table 2 and secure the starter tile at both the drilled hole in the lower 1/3 and at the head of the tile. Seal the head of the fastener with a UV resistant sealant.
2. Prior to installing the starter tile, apply a roof tile adhesive along the entire length of the starter tile. Secure the head of the starter tile with a fastener as specified in Table 2.

Install the remaining hip and ridge tiles with a minimum 3" headlap. Place the nose of the tile into a 4" to 5" bead of roof tile adhesive along the head of the lower tile to insure proper contact with the two tiles. Secure the head of the hip or ridge tile using a fastener as specified in Table 2.

Note: Keep the manufacturer's installation instructions as referenced in the FRSA-TRI Manual at the job site. Use corrosion resistant fasteners as specified in the IRC and the IBC.

Table 2: Hip and Ridge Tile Fastener Requirements

Dimension lumber	Fasteners per Tile
Spruce-Pine-Fir	One (1) No. 8 wood screw
Southern Yellow Pine	One (1) No. 8 screw or One (1) 10d box nail

Table 3 – Iberia

Iberia Moment of Resistance Based on Attachment Method (ft-lbf)				
Attachment System	Roof Slope			
	25°	27°	30°	45°
1-#8	30.50	30.39	30.21	29.04
2-#8	43.77	43.66	43.48	42.31
2-10d ring shank	29.08	28.97	28.79	27.62

Table 3 – Mediterranean

Mediterranean Moment of Resistance Based on Attachment Method (ft-lbf)				
Attachment System	Roof Slope			
	25°	27°	30°	45°
1-#8	42.67	42.56	42.37	41.11
2-#8	67.21	67.10	66.91	65.65
2-10d ring shank	36.80	36.69	36.50	35.24

Table 3 – Tuscany

Tuscany Moment of Resistance Based on Attachment Method (ft-lbf)				
Attachment System	Roof Slope			
	25°	27°	30°	45°
1-#8	32.40	32.28	32.10	30.88
2-#8	45.20	45.08	44.90	43.68
2-10d ring shank	18.82	18.70	18.52	17.30

Table 3 – Windsor

Windsor Moment of Resistance Based on Attachment Method (ft-lbf)				
Attachment System	Roof Slope			
	25°	27°	30°	45°
1-#8	28.27	28.14	27.92	26.51
2-#8	36.18	36.05	35.83	34.42
2-10d ring shank	16.00	15.87	15.65	14.24

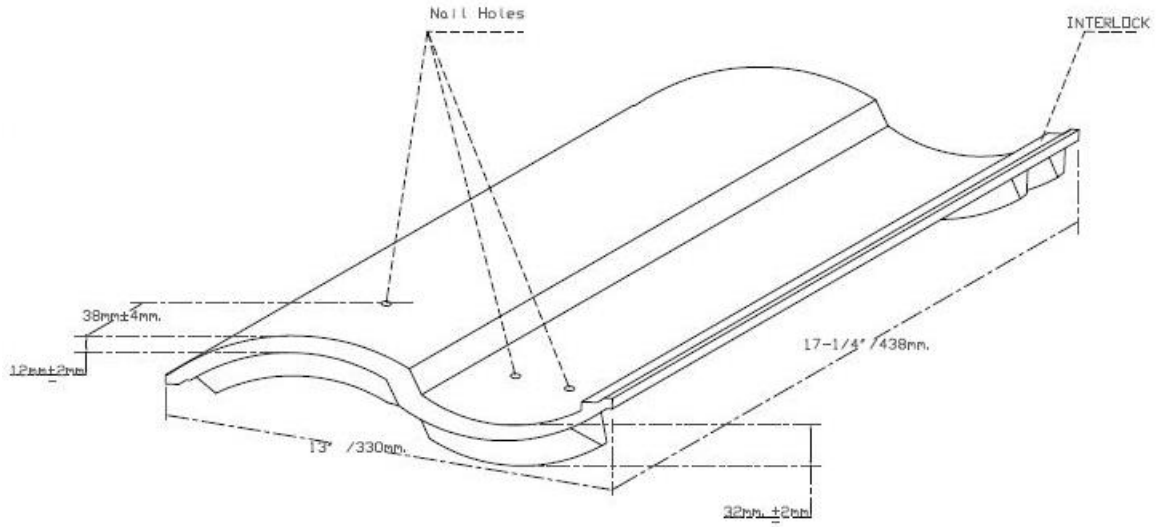

Figure 1
Iberia

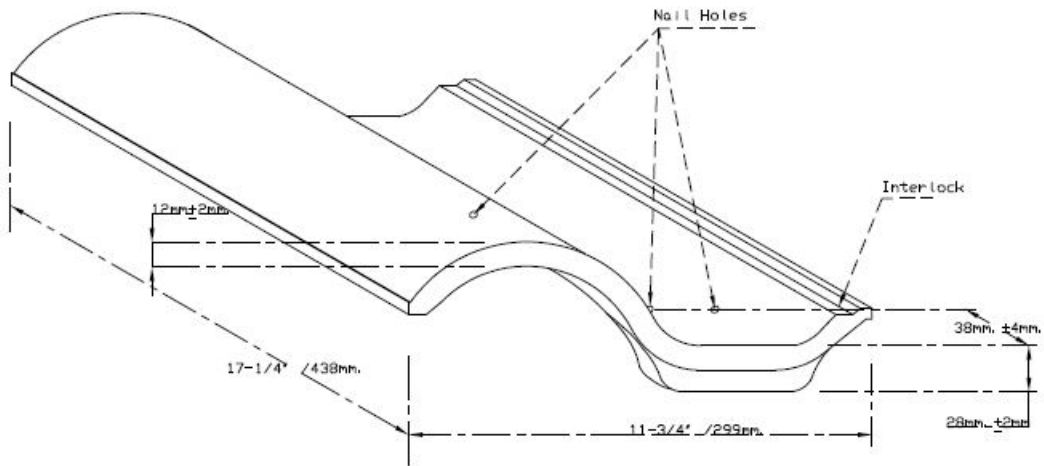

Figure 2
Mediterranean

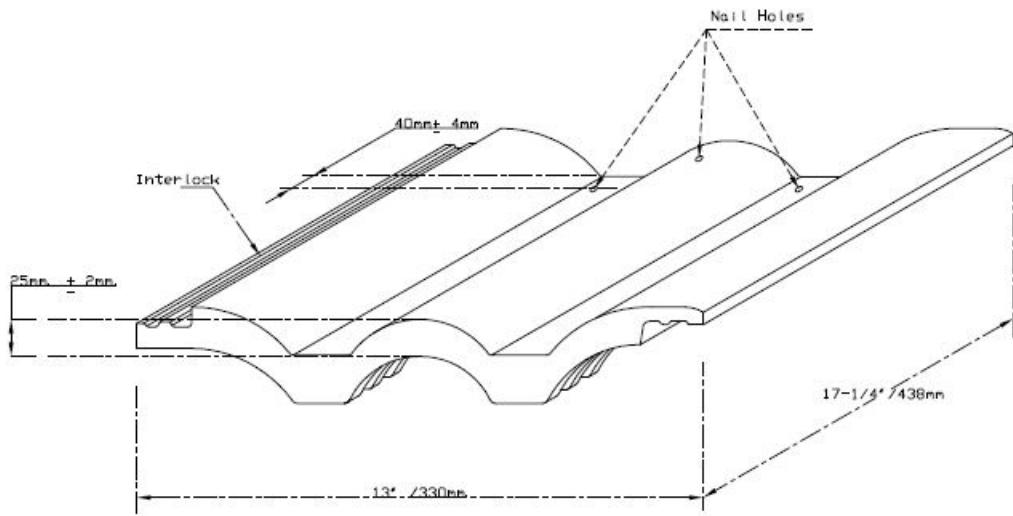

Figure 3
Tuscany

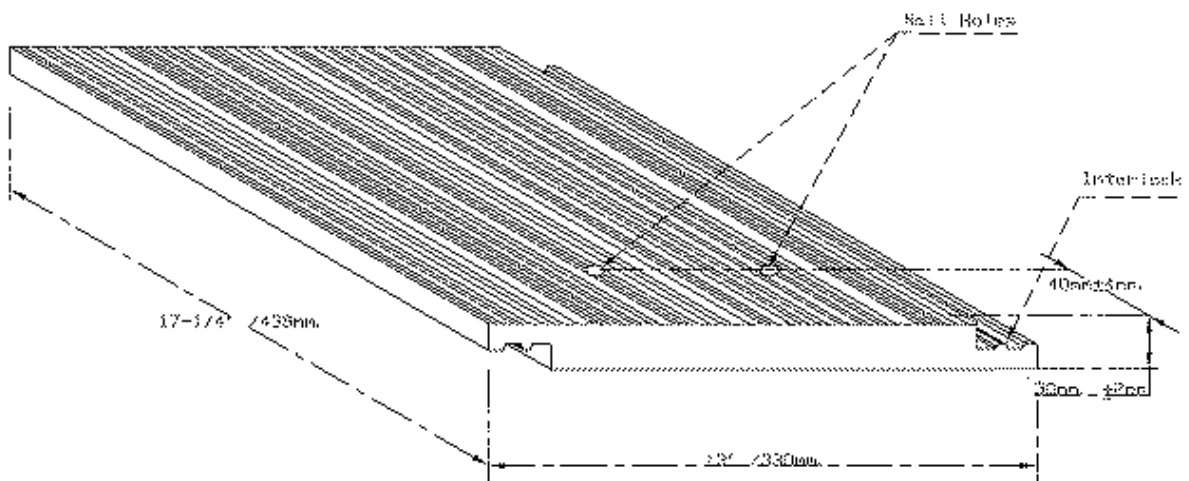

Figure 4
Windsor Shake

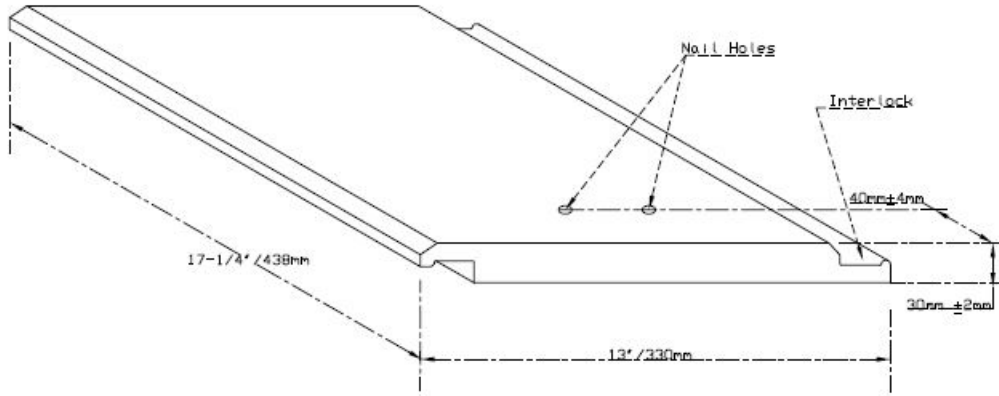

Figure 5
Windsor Slate

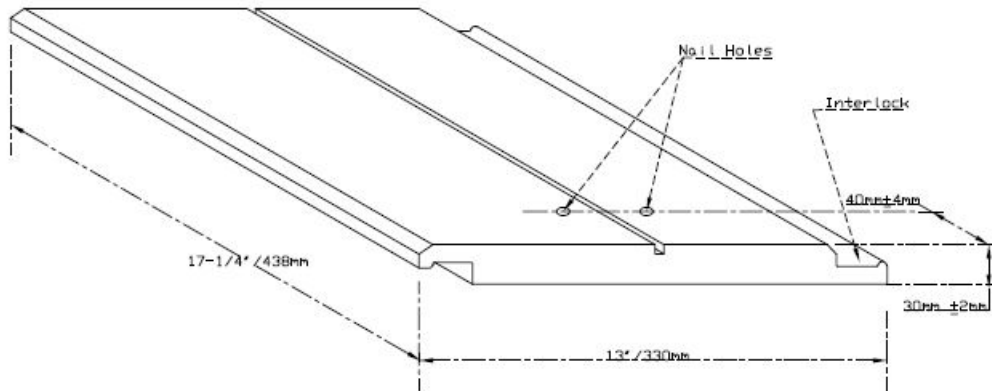

Figure 6
Windsor Split Shake