

## Product Evaluation

RC133 | 1120

Engineering Services Program

The following product has been evaluated for compliance with the wind loads specified in the International Residential Code (IRC) and the International Building Code (IBC).

This product evaluation is not an endorsement of this product or a recommendation that this product be used. The Texas Department of Insurance has not authorized the use of any information contained in the product evaluation for advertising, or other commercial or promotional purpose.

This product evaluation is intended for use by those individuals who are following the design wind load criteria in Chapter 3 of the IRC and Section 1609 of the IBC. The design loads determined for the building or structure shall not exceed the design load rating specified for the products shown in the limitations section of this product evaluation. This product evaluation does not relieve a Texas licensed engineer of his responsibilities as outlined in the Texas Insurance Code, the Texas Administrative Code, and the Texas Engineering Practice Act.

For more information, contact TDI Engineering Services Program at (800) 248-6032.

**Evaluation ID:** RC-133

**Effective Date:** November 1, 2020

**Re-evaluation Date:** November 2024

**Product name:** 5-VEE Steel Roofing Panels Installed Over a Plywood Deck

**Manufacturer:** Central Texas Metal Roofing Supply Co., Inc.  
830 Sagebrush Drive  
Austin, TX 78758  
(512) 452-1515

### General Description:

The 5-VEE metal roofing panels are manufactured from 26-gauge coated steel conforming to ASTM A792, Grade E, with a minimum yield strength of 80,000 psi and 24-gauge coated steel conforming to ASTM A792, Grade 40, with a minimum yield strength of 50,000 psi. The panels have an AZ 55 hot-dip aluminum zinc alloy coating conforming to ASTM A792.

The panels are 24" in width and have a nominal rib height of 1/2".

### Limitations:

**Design Wind Pressure:** For installation of the 5-VEE roof panels to nominal 19/32" plywood panel decks, design wind pressure limitations are specified in Table 1.

**Roof Deck:** The roof deck must be minimum nominal 19/32" plywood. All plywood butt joints must be sealed with caulk or with one-part urethane sealant.

**Roof Deck Attachment:** The roof deck must be secured to the roof framing to resist the required design pressures.

**Installation Over an Existing Roof Covering:** Installation over an existing roof covering is limited to a maximum of one existing layer of composition shingles, wood shingles or shakes, built-up roofing, or roll roofing. The thickness of the plywood deck must comply with the requirements of this evaluation report. Note: Inspection of the existing roof deck must be made before installing the roof panels. The condition of the existing roof deck must be acceptable to receive the roof panels before the roof panel installation can proceed.

**Roof Slope:** The 5-VEE roof panels may be installed on roofs with a roof slope as low as 1/2:12 if sealant is used in the panel side laps. If sealant is not used in the panel side laps, then the minimum roof slope is 3:12.

#### **Installation:**

##### **General Installation Requirements:**

The installation of the panels must be limited to extending 2" beyond the plane of the fascia board.

##### **Panel Installation Requirements:**

**Panels:** Panels must be attached to the roof deck in accordance with Table 1. Refer to Figures 1-11 in this evaluation report for illustrations of the attachment details.

**Table 1** Attachment of 5-VEE Steel Roof Panel to Nominal 19/32" Plywood Deck:

| Wind Pressure (psf) | Attachment of Roof Panel to 19/32" Thick Plywood Deck |                       |
|---------------------|---|-----------------------|
|                     | Fastener Into Roof Deck                               | Fastener Line Spacing |
| -52.5               | One (1) No. 10-14 x 1-1/2" @ 2"-9"-2"-9"              | 36" on center         |

**Underlayment:** Minimum one layer of No. 30 (Type II) asphalt felt must be used. The underlayment used must comply with ASTM D 226, ASTM D 4869, or ASTM D 1970. The felt must be installed with minimum 6" side laps and 3" head laps. The underlayment must be applied with corrosion resistant fasteners in accordance with manufacturer's installation instructions. Fasteners must be applied along the overlaps not farther apart than 36" on center. **Note:** An optional radiant barrier may be installed beneath the panels in conjunction with the underlayment.

#### **Anchorage:**

**Panels:** The 5-VEE roof panels must be secured to the plywood deck in accordance with Table 1 with minimum #10-14 x 1-1/2" Kwikseal Woodbinder screws, manufactured by Sealtite. If the panels are laid directly over an existing roof covering, then minimum #10-14 x 2" Kwikseal Woodbinder screws, manufactured by Sealtite, are required. Refer to Figure 1 for an illustration of the fastening pattern. The fasteners must be long enough to penetrate completely through the wood structural panels with a minimum exposure of 1/4" below the underside of the wood structural panels.

**Ridge Flashing:** The ridge flashing must be installed as shown in Figure 2.

**Valley Trim:** The valley trim must be installed as shown in Figure 3.

**Eave Trim:** The eave trim must be installed as shown in Figure 10.

**Rake Trim:** The rake trim must be installed as shown in Figure 11.

**Alternative Fasteners:** Substitution of equivalent fasteners must meet the following requirements:

#10-14 Kwikseal Woodbinder screws, manufactured by Sealtite.

- Ultimate withdrawal (pullout)  $\geq$  592 lbs. in 19/32" plywood.

**Note:** Keep the manufacturer's installation instructions available on the job site during the installation. Use corrosion resistant fasteners as specified in the IRC and the IBC.

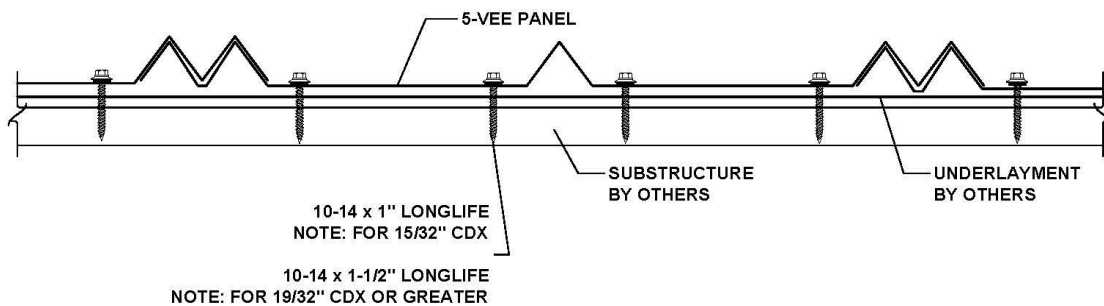

Figure 1: Fastening Pattern

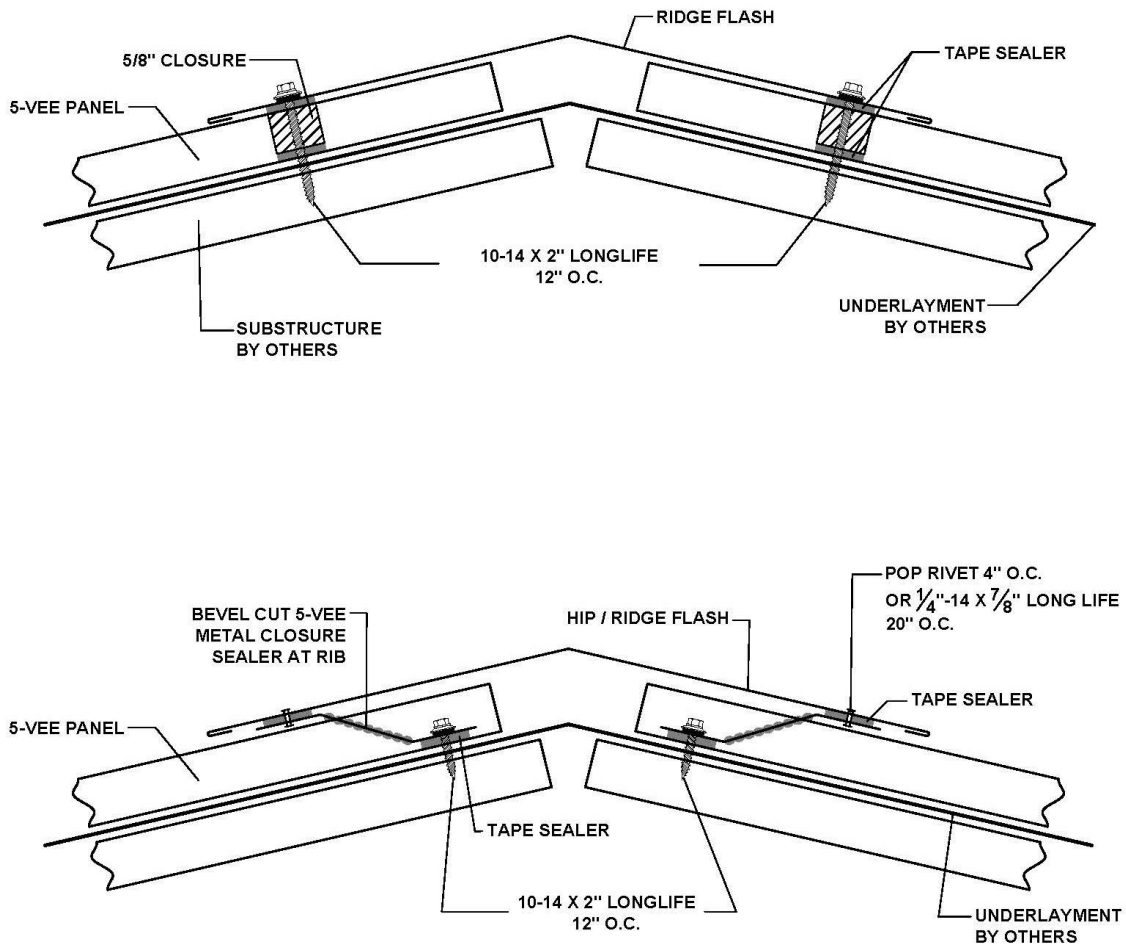

Figure 2: Ridge/Hip Details

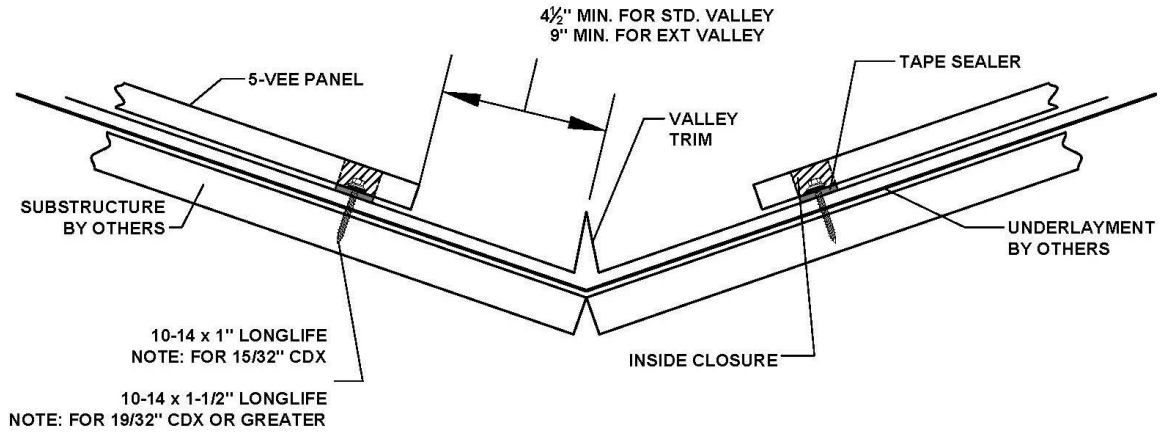

Figure 3: Valley Detail

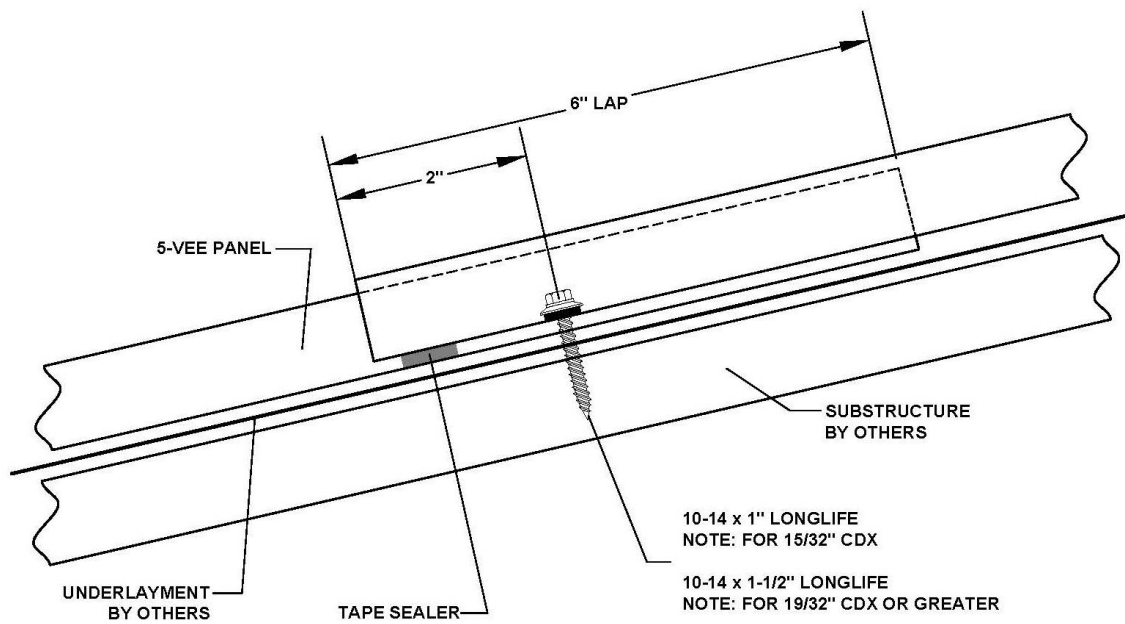

Figure 4: Panel End Lap Detail

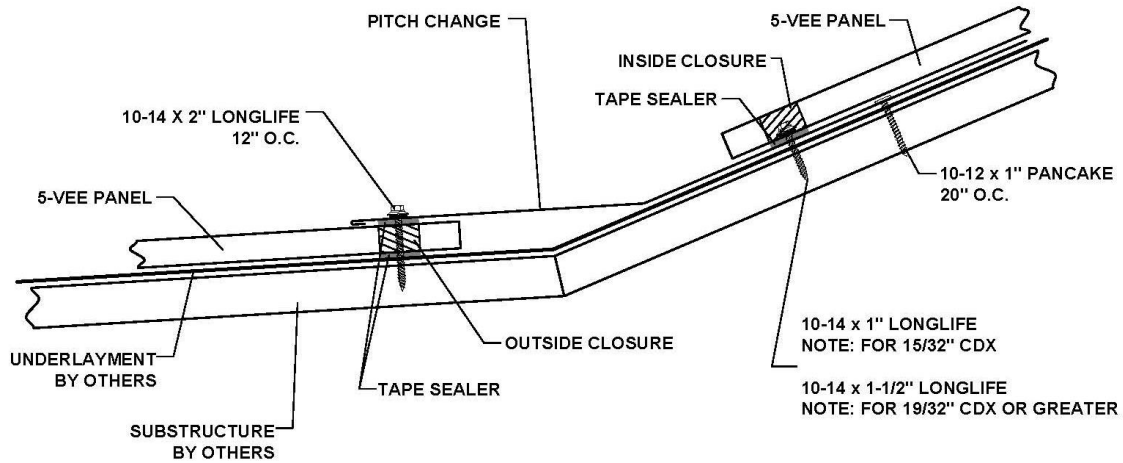

Figure 5: Pitch Change Detail

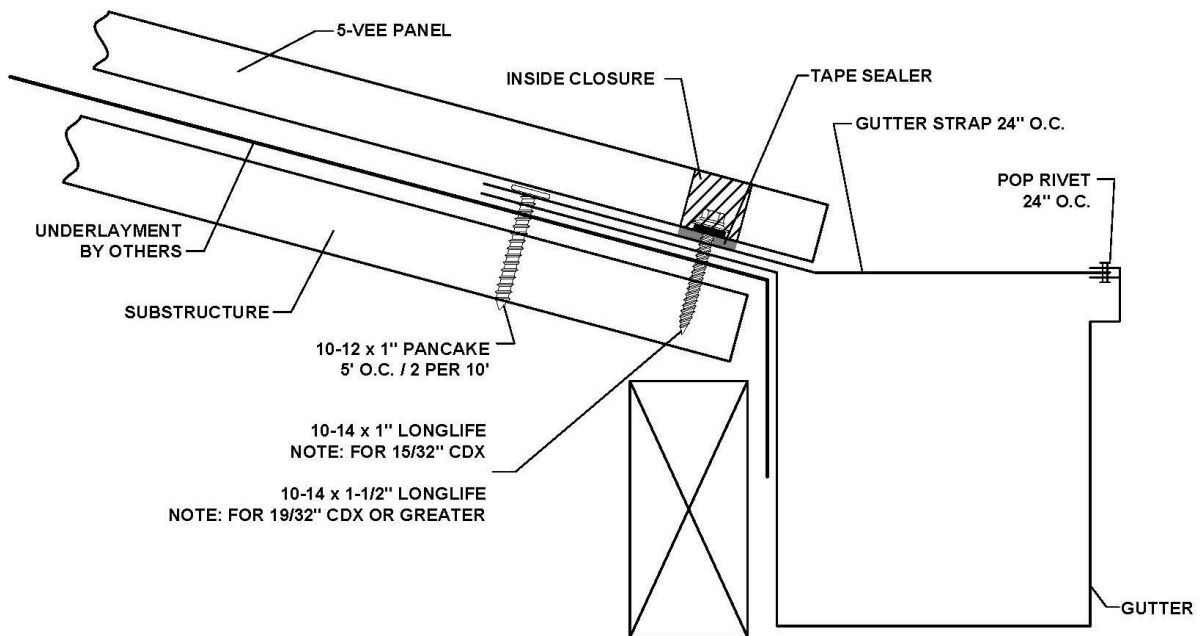

Figure 6: Gutter Detail

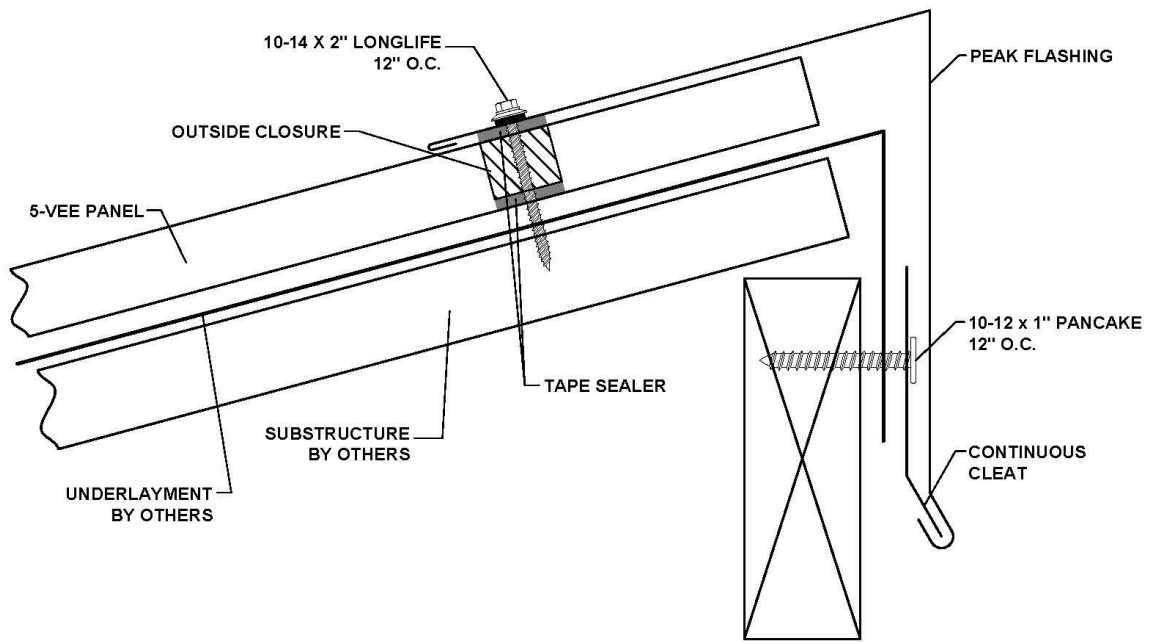

Figure 7: Peak Detail

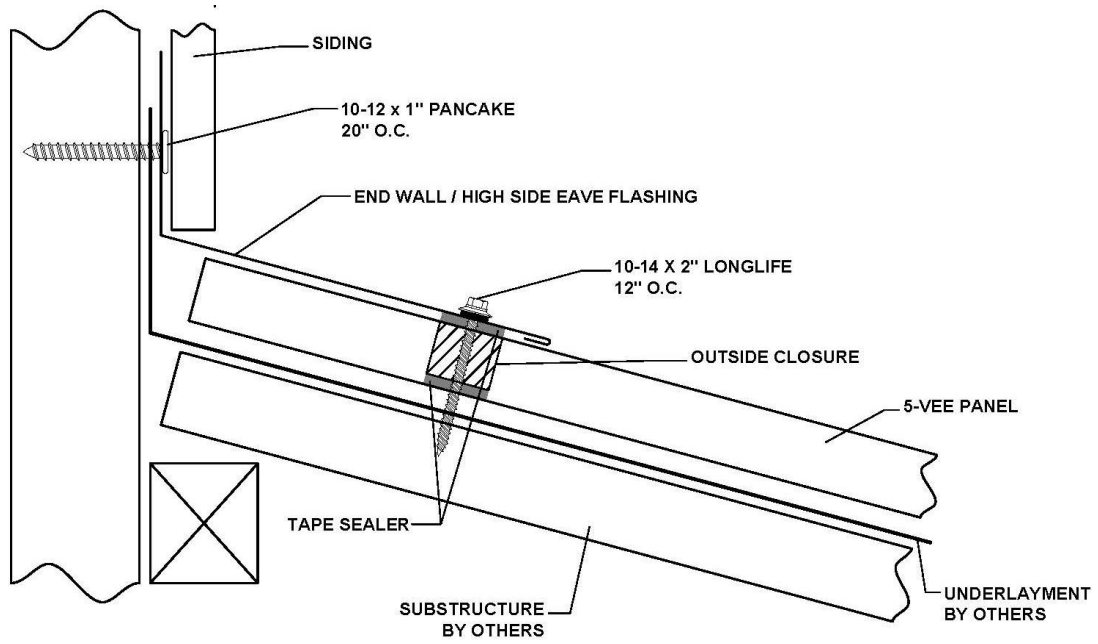

Figure 8: Endwall / Headwall Detail

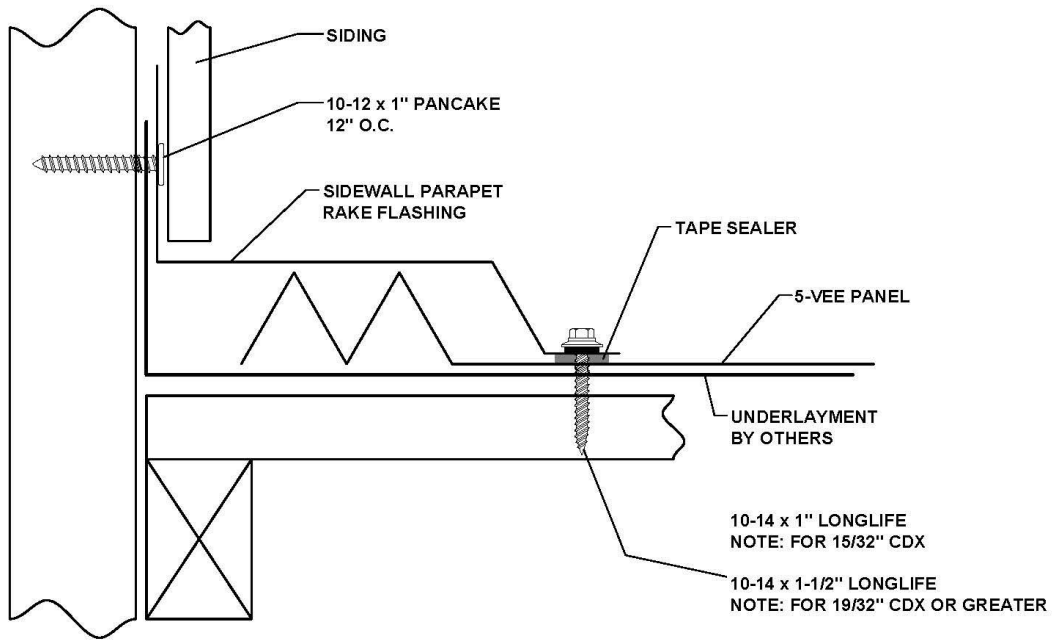

Figure 9: Sidewall Detail

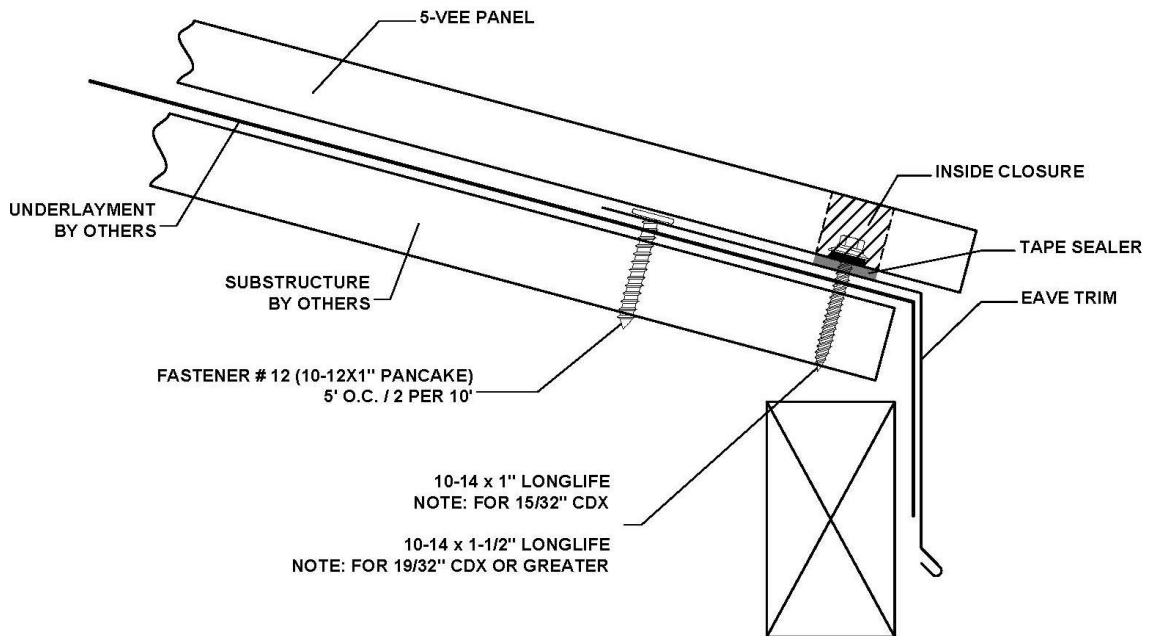

Figure 10: Eave Detail



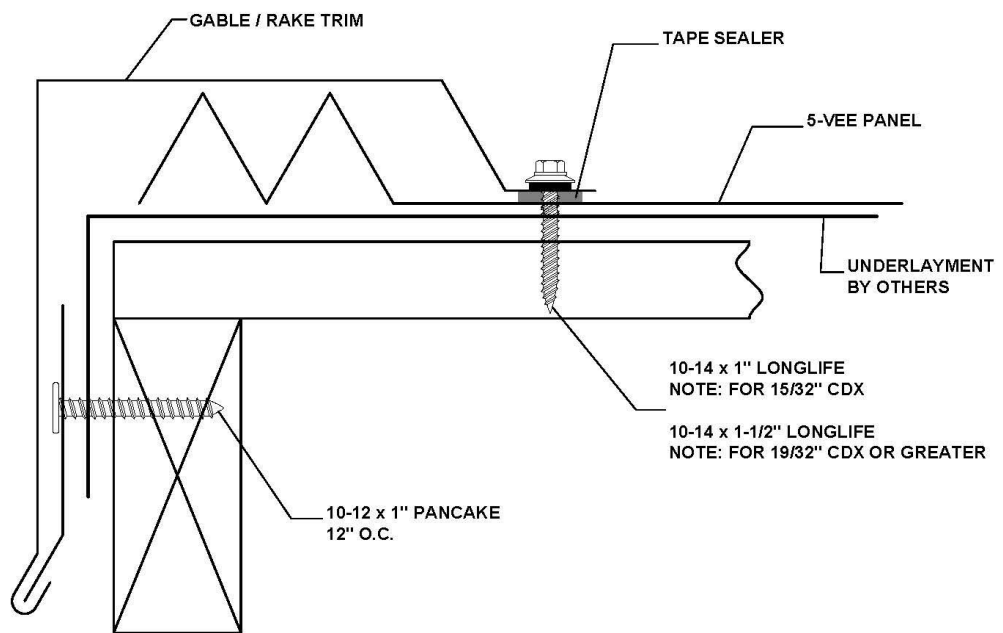

Figure 11: Rake Detail