

**NOTES:**

1. IMPACT RESISTANT GLAZING OPTION - IMPACT RESISTANT GLAZING SYSTEM MAY BE INSTALLED IN ANY OR ALL SECTIONS. GLAZING SHALL BE 1/4" GROOVED POLYCARBONATE. ALUMINUM FRAMES ASSEMBLED WITH (16) SCREWS. MAXIMUM CLEAR OPENING OF 40" X 12-3/4", FASTENED WITH A MINIMUM #8 X 1" SMS. 5X ALONG THE HORIZONTAL AND 3X ALONG THE VERTICAL. SEE DETAIL E ON SHEET 2 FOR ASSEMBLY DETAILS.
2. MINIMUM 1" OVERLAP ON BOTH JAMBS REQUIRED TO MEET NEGATIVE DESIGN PRESSURES.
3. KEY LOCK, SLIDE LOCK, OR OPERATOR REQUIRED.
4. FACER STEEL TO HAVE A MINIMUM 27 GA THICKNESS AND BACKER STEEL TO HAVE A MINIMUM 29 GA THICKNESS.
5. THE DESIGN OF THE SUPPORTING STRUCTURAL ELEMENTS SHALL BE THE RESPONSIBILITY OF THE PROFESSIONAL OF RECORD FOR THE BUILDING OR STRUCTURE AND IN ACCORDANCE WITH CURRENT BUILDING CODES FOR THE LOADS LISTED ON THIS DRAWING.
6. DOOR JAMB TO BE MINIMUM 2x6 SOUTHERN PINE LUMBER. REFER TO JAMB CONNECTION SUPPLEMENT FOR ATTACHMENT TO SUPPORTING STRUCTURE.
7. FOR LOW HEAD ROOM LIFT CONDITIONS, TOP BRACKET SHALL BE A 13 GA LHR 7/4 TOP BRACKET WITHOUT PUSHNUTS AND WITH A MINIMUM OF (3) 1/4-14x7/8" SELF DRILLING CRIMPITE SCREWS IN LIEU OF THE BRACKET SHOWN ON THIS DRAWING. U-BAR ON TOP SECTION SHALL BE INSTALLED ON TOP OF LHR TOP BRACKETS.
8. COMPLIES WITH THE REQUIREMENTS OF IBC/IRC 2018.

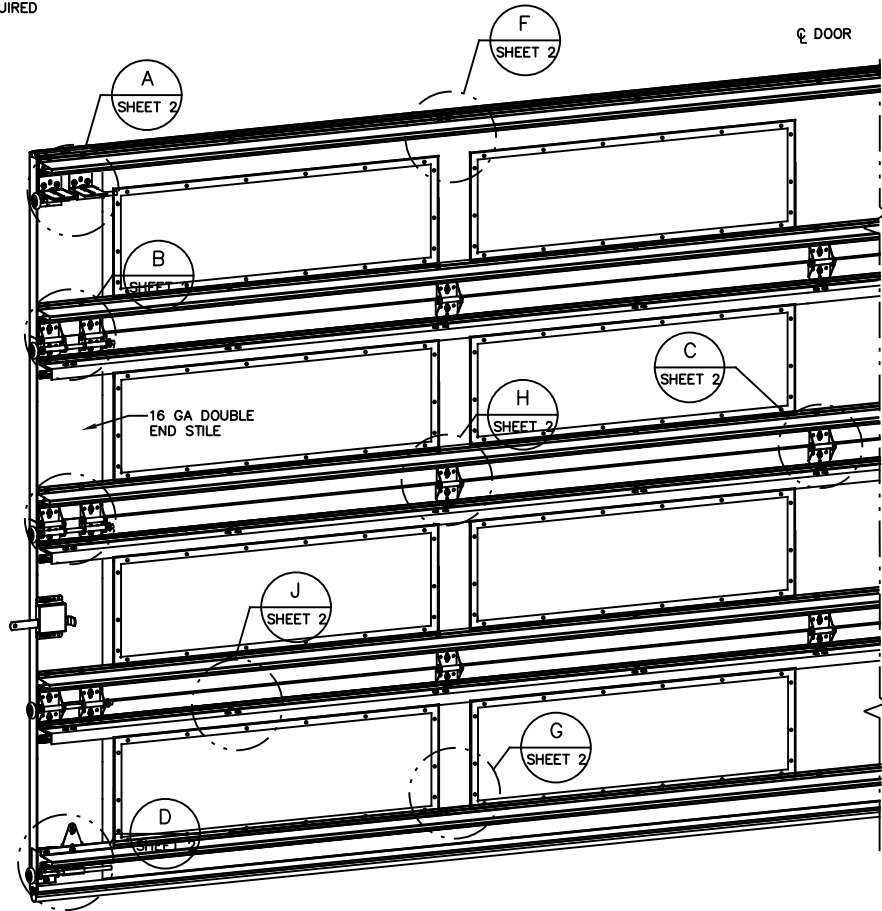
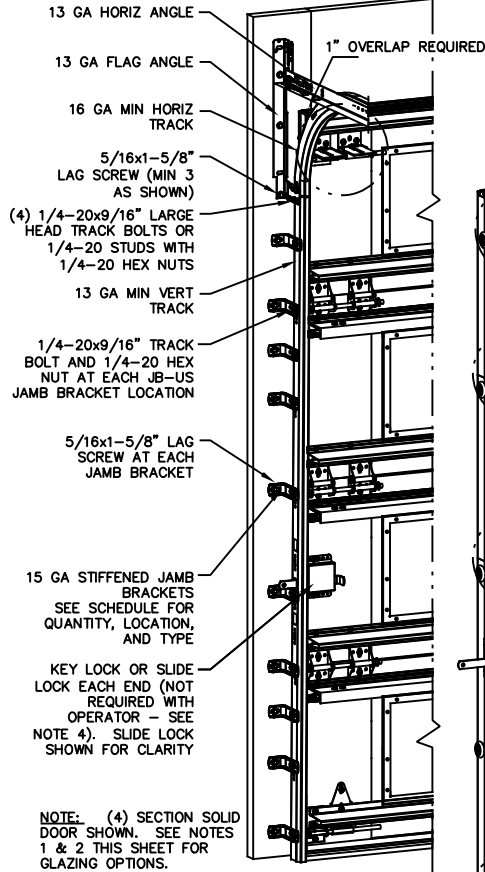

REVISIONS
REV - INITIAL DRAWING JQ 3/23/21

**SUPERIMPOSED DESIGN PRESSURE LOADS ON SUPPORTING STRUCTURE**

DOOR WIDTH	DOOR HEIGHT	UNIFORM LOAD EACH JAMB (PLF)
10'-2"	ALL	+209.9/-237.3
12'-2"	ALL	+251.2/-284.0
14'-2"	ALL	+292.2/-330.7
15'-2"	ALL	+313.1/-354.1
16'-2"	ALL	+333.8/-377.4

**JAMB BRACKET SCHEDULE**

DOOR HEIGHT	NO. OF SECTIONS	NO. OF JAMB BRACKETS (EACH JAMB)	LOCATION OF CENTERLINE OF JAMB BRACKETS MEASURED FROM BOTTOM OF TRACK (ALL DIMENSIONS ± 2")
6'-6"	4	9	2", 10", 16", 21-3/4", 29-3/4", 42", 48", 55", 63-1/4"
7'-0"	4	9	2", 10", 16", 21-3/4", 29-3/4", 42", 48", 55", 63-1/4"
7'-6"	4 OR 5	11	2", 10", 16", 21-3/4", 29-3/4", 40", 48", 57-1/4", 66", 71", 75-1/2"
8'-0"	4 OR 5	11	2", 10", 16", 21-3/4", 29-3/4", 40", 48", 57-1/4", 66", 71", 75-1/2"
> 8'-0"			SEE NOTE BELOW

NOTE: (JB-US) FOLLOWING DIMENSION DENOTES SLOTTED JAMB BRACKET ATTACHED TO TRACK WITH 1/4-20x9/16" TRACK BOLT AND NUT AS SHOWN ABOVE. ALL DOORS GREATER THAN 8' IN HEIGHT REQUIRE USE OF CONTINUOUS WALL ANGLE. SEE SUPPLEMENT TRACK CHART FOR DETAILS.

PSF VALUES NEED TO BE VERIFIED



STATIC PRESSURE RATINGS	APPROVED SIZES	SCALE: N.T.S.	SIZE: A
DESIGN (PSF): +41.30/-46.70	MAX WIDTH: 16'-2"	DATE	NAME
TEST (PSF): +61.95/-70.05	MAX HEIGHT: 24'-1"	DRAWN 03/09/21	JQ
IMPACT/CYCLIC RATED (YES/NO): YES	MAX SECTION HEIGHT: 24'	CHECKED 03/31/21	DK
MODELS 5745/5765/7565/7655/515/525		SHEET 1 OF 2	
WINDLOAD SPECIFICATION OPTION CODE 2612		DRAWING PART NO. 411902	REV. -

JOHN E. SCATES, PE  
2560 KING ARTHUR #124-54  
LEWISVILLE, TX 75056  
FL PE 51737  
TX PE 56308/F2203

PROFESSIONAL ENGINEER'S SEAL PROVIDED ONLY FOR VERIFICATION OF WINDLOAD CONSTRUCTION DETAILS.

(2) 12 GA COMMERCIAL 'L' FRAME TOP BRACKETS ATTACHED WITH (4) 1/4-20x7/8" SELF DRILLING SCREWS (2 THROUGH STRUT AND TOP BRACKET)

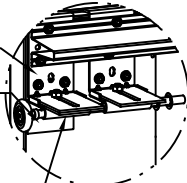

'L' FRAME REINFORCING ANGLE BRACKET ATTACHED WITH (1) 1/4-20x7/8" SELF DRILLING SCREWS

13 GA ROLLER SLIDE ATTACHED TO BRACKET WITH 5/16-18 BOLT & NUT IN THE CENTER SLOT

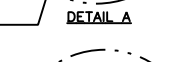

2" STEEL ROLLER WITH 9" GRADE 1144 OR EQUIVALENT STEM, 1/4" MAX BETWEEN PUSH NUT AND OUTER HINGE. OPTIONAL - 11 BALL BEARING NYLON ROLLER WITH 1144 OR EQUIVALENT STEM.

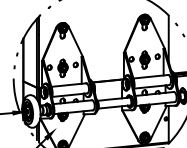

(2) WIDE BODY END HINGES EACH ATTACHED WITH (4) 1/4-14x7/8" SELF DRILLING CRIMPITITE SCREWS



DOUBLE END HINGE #1 HINGE 14GA #2 HINGE 13GA #3 HINGE 13GA



14 GA WIDE BODY INTERMEDIATE HINGE ATTACHED WITH (4) 1/4-14x7/8" SELF DRILLING CRIMPITITE SCREWS

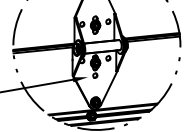

12 GA EXTENSION BRACKET ATTACHED WITH (4) 1/4-14x7/8" SELF DRILLING CRIMPITITE SCREWS

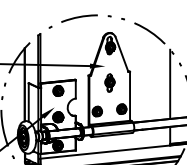

14 GA BOTTOM BRACKET ATTACHED WITH (2) 1/4-14x7/8" SELF DRILLING CRIMPITITE SCREWS THROUGH STRUT AND BOTTOM BRACKET AND (1) 1/4-14x5/8" SELF DRILLING TAMPER RESISTANT SCREW



TOP U-BAR SHALL BE ATTACHED WITH (4) 1/4-14x7/8" SELF DRILLING CRIMPITITE SCREWS AT EACH HINGE LOCATION AND (2) 1/4-14x7/8" SELF DRILLING CRIMPITITE SCREWS BETWEEN ALL END HINGES AND INTERMEDIATE HINGES.

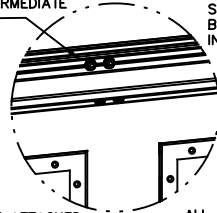

U-BARS WITH 2X2X12GA ANGLES SHALL BE ATTACHED WITH (3) 1/4-14x7/8" SELF DRILLING CRIMPITITE SCREWS AT EACH HINGE LOCATION AND (2) 1/4-14x7/8" SELF DRILLING CRIMPITITE SCREWS BETWEEN ALL END HINGES AND INTERMEDIATE HINGES.

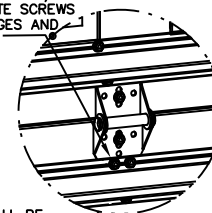

BOTTOM U-BAR SHALL BE ATTACHED WITH (4) 1/4-14x7/8" SELF DRILLING CRIMPITITE SCREWS AT EACH HINGE LOCATION AND (2) 1/4-14x7/8" SELF DRILLING CRIMPITITE SCREWS BETWEEN ALL END HINGES AND INTERMEDIATE HINGES

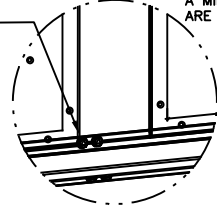

ALL 2X2X12GA ANGLE SHALL BE ATTACHED WITH (2) 1/4-14x7/8" SELF DRILLING CRIMPITITE SCREWS SIDE BY SIDE AT EACH HINGE LOCATION AND BETWEEN ALL END HINGES AND INTERMEDIATE HINGES. A MINIMUM OF (18) FASTENERS ARE TO BE USED.

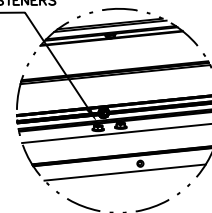

DETAIL G

IMPACT FRAME SIZE	DAYLIGHT OPENING (DLO)	SCREW QTY
19.2 X 15.3	15 X 11	10
19.8 X 16.8	15.75 X 12.75	10
40 X 12.8	35.8 X 8.6	14
42 X 16.8	37.8 X 12.75	14
41.2 X 7.1	37 X 3	12
44.1 X 15.5	40.13 X 11.25	16

ALL 2X2X12GA ANGLE SHALL BE ATTACHED WITH (2) 1/4-14x7/8" SELF DRILLING CRIMPITITE SCREWS AT EACH HINGE LOCATION AND BETWEEN ALL END HINGES AND INTERMEDIATE HINGES. A MINIMUM OF (18) FASTENERS ARE TO BE USED.

(4) SECTION DOORS WITH (8) 3" 18 GA 80 KSI U-BARS (3) 2X2X12GA ANGLES LOCATED AS SHOWN

(5) SECTION DOORS WITH (10) 3" 18 GA 80 KSI U-BARS (4) 2X2X12GA ANGLES LOCATED AS SHOWN

(6) SECTION DOORS WITH (12) 3" 18 GA 80 KSI U-BARS (5) 2X2X12GA ANGLES LOCATED AS SHOWN

(7) SECTION DOORS WITH (14) 3" 18 GA 80 KSI U-BARS (6) 2X2X12GA ANGLES LOCATED AS SHOWN

(8) SECTION DOORS WITH (16) 3" 18 GA 80 KSI U-BARS (7) 2X2X12GA ANGLES LOCATED AS SHOWN

(9) SECTION DOORS WITH (18) 3" 18 GA 80 KSI U-BARS (8) 2X2X12GA ANGLES LOCATED AS SHOWN

(10) SECTION DOORS WITH (20) 3" 18 GA 80 KSI U-BARS (9) 2X2X12GA ANGLES LOCATED AS SHOWN

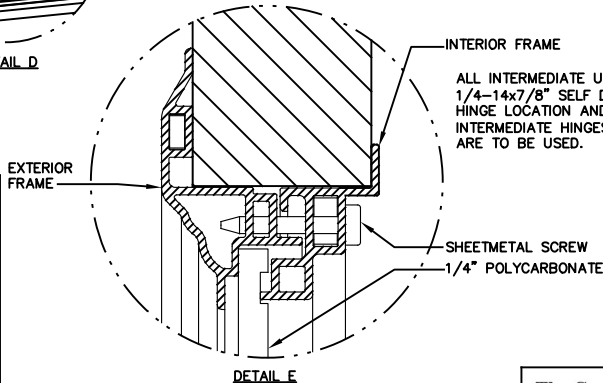

INTERIOR FRAME

ALL INTERMEDIATE U-BARS SHALL BE ATTACHED WITH (2) 1/4-14x7/8" SELF DRILLING CRIMPITITE SCREWS AT EACH HINGE LOCATION AND BETWEEN ALL END HINGES AND INTERMEDIATE HINGES. A MINIMUM OF (22) FASTENERS ARE TO BE USED.

EXTERIOR FRAME

SHEETMETAL SCREW  
1/4" POLYCARBONATE

PSF VALUES NEED TO BE VERIFIED

The Genuine. The Original.



A DIVISION OF OVERHEAD DOOR CORP  
3395 ADDISON DRIVE  
PENSACOLA, FLORIDA 32514  
(850) 474-9890

STATIC PRESSURE RATINGS		APPROVED SIZES		SCALE: N.T.S.		SIZE: A	
DESIGN (PSF):	+41.30/-46.70	MAX WIDTH:	16'-2"	DATE	NAME		
TEST (PSF):	+61.95/-70.05	MAX HEIGHT:	24'-1"	DRAWN	03/09/21	JQ	
IMPACT/CYCLIC RATED (YES/NO):	YES	MAX SECTION HEIGHT:	24"	CHECKED	03/31/21	DK	
MODELS 5745/5765/7565/7655/515/525				SHEET 2 OF 2			
WINDLOAD SPECIFICATION OPTION CODE 2612				DRAWING PART NO.		REV.	
				411902		-	

JOHN E. SCATES, PE  
2560 KING ARTHUR #124-54  
LEWISVILLE, TX 75056  
FL PE 51737  
TX PE 56308/F2203

PROFESSIONAL ENGINEER'S SEAL PROVIDED ONLY FOR VERIFICATION OF WINDLOAD CONSTRUCTION DETAILS.