

NOTES:

1. IMPACT RESISTANT GLAZING OPTION - IMPACT RESISTANT GLAZING SYSTEM MAY BE INSTALLED IN ANY OR ALL SECTIONS. GLAZING SHALL BE 1/4" GROOVED POLYCARBONATE. ALUMINUM FRAMES ASSEMBLED WITH (16) SCREWS. MAXIMUM CLEAR OPENING OF 40" X 12-3/4", FASTENED WITH A MINIMUM #8 X 1" SMS: 5X ALONG THE HORIZONTAL AND 3X ALONG THE VERTICAL. SEE DETAIL E ON SHEET 2 FOR ASSEMBLY DETAILS.

2. NON-IMPACT RESISTANT GLAZING OPTION - 3/32" MINIMUM SSB ANNEALED GLAZING IN MOLDED FRAMES SCREWED TOGETHER WITH A MINIMUM OF (14) #8x1" SCREWS WITH WASHERS (2X ALONG THE VERTICAL AND 5X ALONG THE HORIZONTAL) INSTALLED IN ANY OR ALL SECTIONS MEETS UNIFORM STATIC WIND PRESSURES SHOWN ON THIS DRAWING. MAXIMUM GLAZING DIMENSIONS SHALL BE 38.5" X 13" CLEAR OPENING. GLASS IS NOT IMPACT RESISTANT AND DOES NOT MEET THE REQUIREMENTS FOR WIND-BORNE DEBRIS REGIONS. SEE DETAIL F ON SHEET 2 FOR ASSEMBLY DETAILS.

ALTERNATE OPTION- 1/2" INSULATED DSB ANNEALED GLAZING IN ALUMINUM EXTERIOR FRAME/PLASTIC MOLDED INTERIOR FRAME SCREWED TOGETHER WITH A MINIMUM OF (14) #8x1" SCREWS (2X ALONG THE HORIZONTAL AND 5X ALONG THE HORIZONTAL) INSTALLED IN ANY OR ALL SECTIONS MEETS UNIFORM STATIC WIND PRESSURES SHOWN ON THIS DRAWING. MAXIMUM GLAZING DIMENSIONS SHALL BE 39" X 5-1/6" CLEAR OPENING. GLASS IS NOT IMPACT RESISTANT AND DOES NOT MEET THE REQUIREMENTS FOR WIND-BORNE DEBRIS REGIONS. SEE DETAIL G ON SHEET 2 FOR ASSEMBLY DETAILS.

3. MINIMUM 1" OVERLAP ON BOTH JAMBS REQUIRED TO MEET NEGATIVE DESIGN PRESSURES.

4. KEY LOCK, SLIDE LOCK, OR OPERATOR REQUIRED.

5. FACER STEEL TO HAVE A MINIMUM 27 GA THICKNESS AND BACKER STEEL TO HAVE A MINIMUM 29 GA THICKNESS.

6. THE DESIGN OF THE SUPPORTING STRUCTURAL ELEMENTS SHALL BE THE RESPONSIBILITY OF THE PROFESSIONAL OF RECORD FOR THE BUILDING OR STRUCTURE AND IN ACCORDANCE WITH CURRENT BUILDING CODES FOR THE LOADS LISTED ON THIS DRAWING.

7. DOOR JAMB TO BE MINIMUM 2x6 SOUTHERN PINE LUMBER. REFER TO JAMB CONNECTION SUPPLEMENT FOR ATTACHMENT TO SUPPORTING STRUCTURE.

8. FOR LOW HEAD ROOM LIFT CONDITIONS, TOP BRACKET SHALL BE A 13 GA LHR 7/4 TOP BRACKET WITHOUT PUSHNUTS AND WITH A MINIMUM OF (3) 1/4-14x7/8" SELF DRILLING CRIMPITE SCREWS IN LIEU OF THE BRACKET SHOWN ON THIS DRAWING. U-BAR ON TOP SECTION SHALL BE INSTALLED ON TOP OF LHR TOP BRACKETS.

9. COMPLIES WITH THE REQUIREMENTS OF IBC/IRC 2018.

SUPERIMPOSED DESIGN PRESSURE LOADS ON SUPPORTING STRUCTURE

DOOR WIDTH	DOOR HEIGHT	UNIFORM LOAD EACH JAMB (PLF)
10'-2"	ALL	+181.4/-208.4
12'-2"	ALL	+217.1/-249.4
14'-2"	ALL	+252.8/-290.4
15'-2"	ALL	+270.7/-310.9
16'-2"	ALL	+288.5/-331.4

NOTE: (JB-US) FOLLOWING DIMENSION DENOTES SLOTTED JAMB BRACKET ATTACHED TO TRACK WITH 1/4-20x9/16" TRACK BOLT AND NUT AS SHOWN ABOVE.

ALL DOORS GREATER THAN 8' IN HEIGHT REQUIRE USE OF CONTINUOUS WALL ANGLE. SEE SUPPLEMENT TRACK CHART FOR DETAILS.

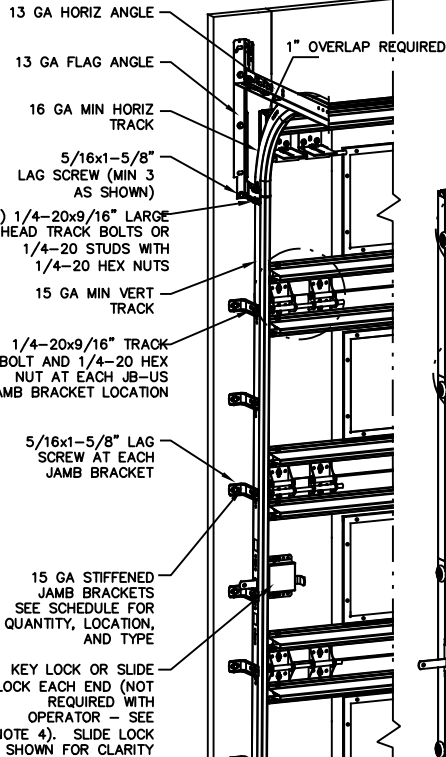

NOTE: (4) SECTION SOLID DOOR SHOWN. SEE NOTES 1 & 2 THIS SHEET FOR GLAZING OPTIONS.

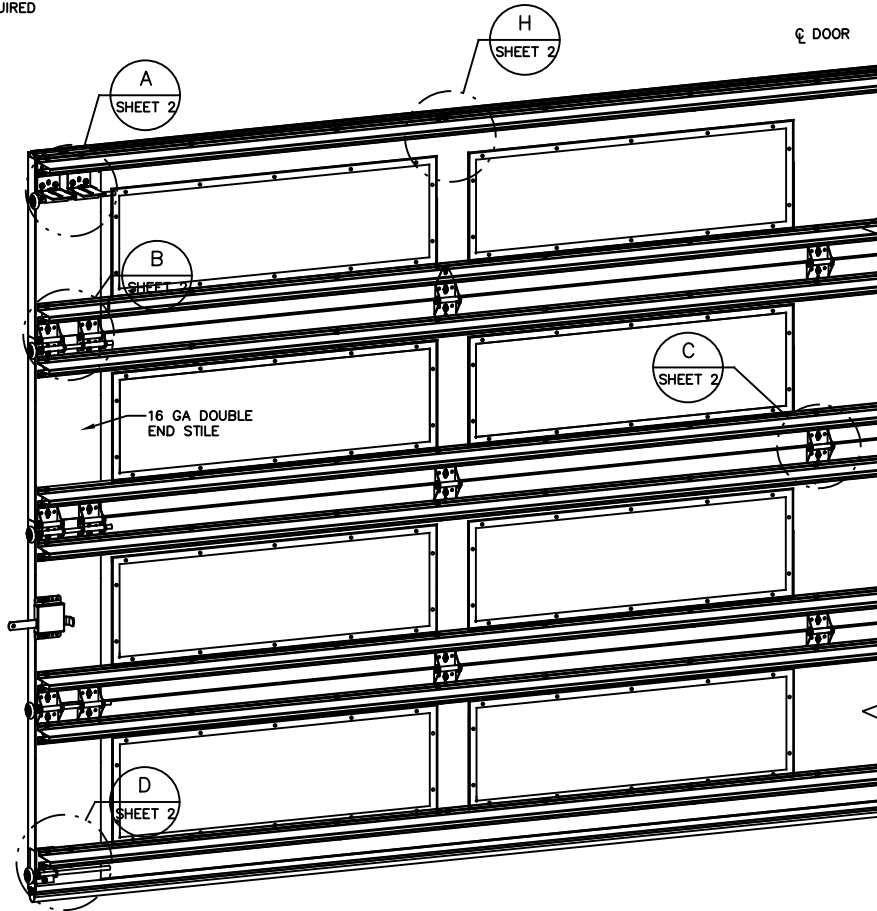

JAMB BRACKET SCHEDULE

DOOR HEIGHT	NO. OF SECTIONS	NO. OF JAMB BRACKETS (EACH JAMB)	LOCATION OF CENTERLINE OF JAMB BRACKETS MEASURED FROM BOTTOM OF TRACK (ALL DIMENSIONS ± 2")
6'-6"	4	7	2" (JB-US), 10" (JB-US), 21-3/4" (JB-US), 29-3/4" (JB-US), 39" (JB-US), 48" (JB-US), 57-1/4" (JB-US)
7'-0"	4	7	2" (JB-US), 10" (JB-US), 21-3/4" (JB-US), 29-3/4" (JB-US), 42" (JB-US), 52-1/2" (JB-US), 63-1/4" (JB-US)
7'-6"	4 OR 5	8	2" (JB-US), 10" (JB-US), 18-3/4" (JB-US), 26-3/4" (JB-US), 36" (JB-US), 45" (JB-US), 54-1/4" (JB-US), 74-1/2" (JB-US)
8'-0"	4 OR 5	8	2" (JB-US), 10" (JB-US), 21-3/4" (JB-US), 29-3/4" (JB-US), 39" (JB-US), 48" (JB-US), 57-1/2" (JB-US), 75-1/2" (JB-US)
> 8'-0"			SEE NOTE BELOW

The Genuine. The Original.



A DIVISION OF OVERHEAD DOOR CORP
3395 ADDISON DRIVE
PENSACOLA, FLORIDA 32514
(850) 474-9890

STATIC PRESSURE RATINGS		APPROVED SIZES		SCALE: N.T.S.		SIZE: A	
DESIGN (PSF):	+36.80/-41.60	MAX WIDTH:	16'-2"	DATE	NAME		
TEST (PSF):	+55.20/-62.40	MAX HEIGHT:	24'-0"	DRAWN	03/09/21 JQ		
IMPACT/CYCLIC RATED (YES/NO): YES		MAX SECTION HEIGHT:	24"	CHECKED	03/31/21 DK		
MODELS 5745/5765/7565/7655/515/525				SHEET 1 OF 2			
WINDLOAD SPECIFICATION OPTION CODE 2611				DRAWING PART NO.	REV.		
				411901	-		

REVISIONS
REV - INITIAL DRAWING
JQ 3/09/21

JOHN E. SCATES, PE
2560 KING ARTHUR #124-54
LEWISVILLE, TX 75056
FL PE 51737
TX PE 56308/P2203

PROFESSIONAL ENGINEER'S SEAL PROVIDED ONLY FOR VERIFICATION OF WINDLOAD CONSTRUCTION DETAILS.

(2) 12 GA COMMERCIAL 'L' FRAME TOP BRACKETS ATTACHED WITH (4) 1/4-20x7/8" SELF DRILLING SCREWS (2 THROUGH STRUT AND TOP BRACKET)

'L' FRAME REINFORCING ANGLE BRACKET ATTACHED WITH (1) 1/4-20x7/8" SELF DRILLING SCREWS

13 GA ROLLER SLIDE ATTACHED TO BRACKET WITH 5/16-18 BOLT & NUT IN THE CENTER SLOT

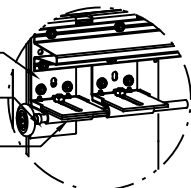

DETAIL A

1/8" BEAD OF BOSTICK 1100 OR EQUIVALENT

2" STEEL ROLLER WITH 9" GRADE 1144 OR EQUIVALENT STEM. OPTIONAL - 1" BALL BEARING NYLON ROLLER WITH 1144 OR EQUIVALENT STEM.

(2) WIDE BODY END HINGES EACH ATTACHED WITH (4) 1/4-14x7/8" SELF DRILLING CRIMPITITE SCREWS

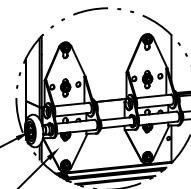

DETAIL B

DOUBLE END HINGE #1 HINGE 14GA #2 HINGE 13GA #3 HINGE 13GA

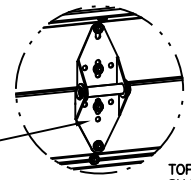

DETAIL C

14 GA WIDE BODY INTERMEDIATE HINGE ATTACHED WITH (4) 1/4-14x7/8" SELF DRILLING CRIMPITITE SCREWS

TOP AND BOTTOM U-BARS SHALL BE ATTACHED WITH (4) 1/4-14x7/8" SELF DRILLING CRIMPITITE SCREWS AT EACH HINGE LOCATION.

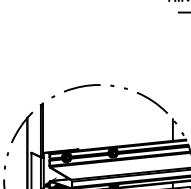

DETAIL D

14 GA BOTTOM BRACKET ATTACHED WITH (2) 1/4-14x7/8" SELF DRILLING CRIMPITITE SCREWS THROUGH STRUT AND BOTTOM BRACKET AND (1) 1/4-14x5/8" SELF DRILLING TAMPER RESISTANT SCREW

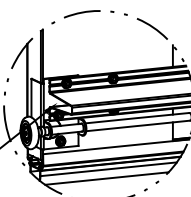

DETAIL E

JOHN E. SCATES, PE
2560 KING ARTHUR #124-54
LITTLEVILLE, TX 75056
FL PE 51737
TX PE 56308/F2203

PROFESSIONAL ENGINEER'S SEAL PROVIDED ONLY FOR VERIFICATION OF WINDLOAD CONSTRUCTION DETAILS.

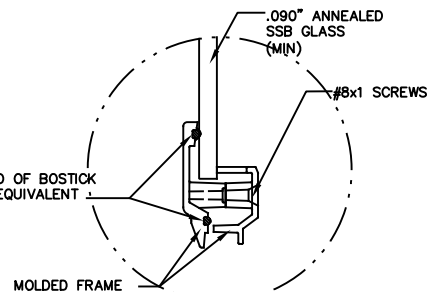

PLASTIC FRAME (STATIC RATED) DETAIL F

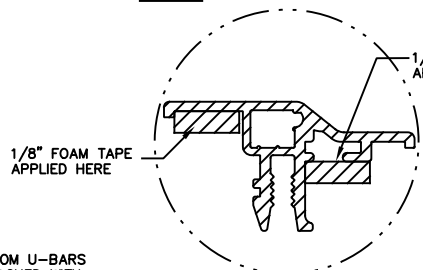

ALUMINUM FRAME (STATIC RATED ALTERNATE FRAME OPTION) DETAIL G

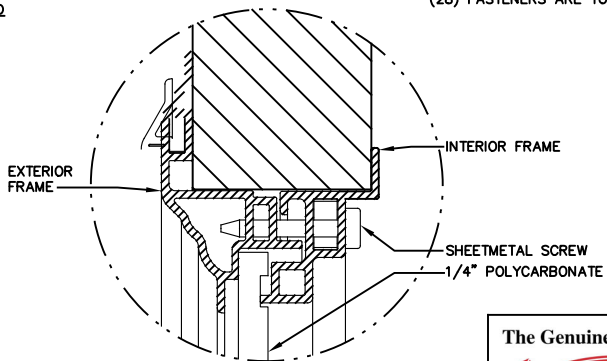

DETAIL H

ALL INTERMEDIATE U-BARS SHALL BE ATTACHED WITH (2) 1/4-14x7/8" SELF DRILLING CRIMPITITE SCREWS AND ALL TOP AND BOTTOM U-BARS SHALL BE ATTACHED WITH (4) 1/4-14x7/8" SELF DRILLING CRIMPITITE SCREWS AT EACH HINGE LOCATION. ALL U-BARS SHALL BE ATTACHED WITH (4) 1/4-14x7/8" SELF DRILLING CRIMPITITE SCREWS BETWEEN ALL END HINGES AND INTERMEDIATE HINGES. A MINIMUM OF (28) FASTENERS ARE TO BE USED.

STATIC FRAME SIZE	DAYLIGHT OPENING (DLO)	SCREW QTY
18.74 X 13.76	15 X 11	10
18.25 X 15.25	15.75 X 12.75	6
39.88 X 12.69	35.8 X 8.6	14
40.50 X 15.25	37.8 X 12.75	14
40.75 X 7	37.75 X 4	14
43.96 X 15.09	40.13 X 11.25	22

IMPACT FRAME SIZE	DAYLIGHT OPENING (DLO)	SCREW QTY
19.2 X 15.3	15 X 11	10
19.8 X 16.8	15.75 X 12.75	10
40 X 12.8	35.8 X 8.6	14
42 X 16.8	37.8 X 12.75	14
41.2 X 7.1	37 X 3	12
44.1 X 15.5	40.13 X 11.25	16

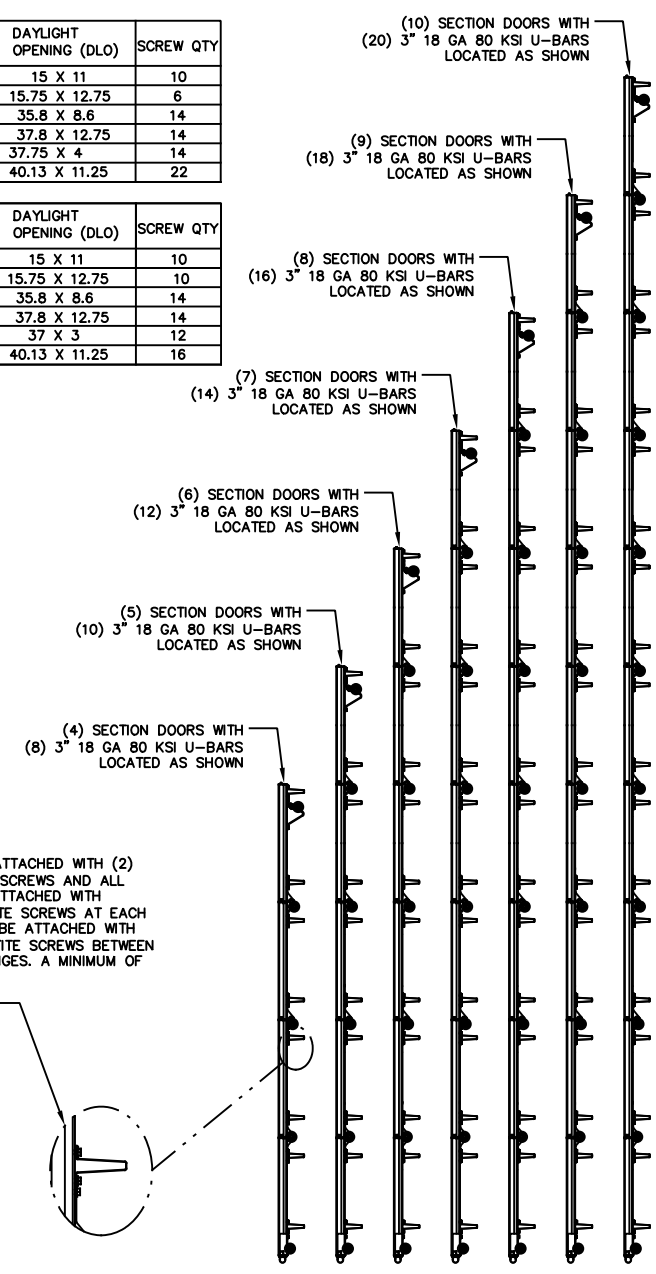

The Genuine. The Original.



A DIVISION OF OVERHEAD DOOR CORP
3395 ADDISON DRIVE
PENSACOLA, FLORIDA 32514
(850) 474-9890

STATIC PRESSURE RATINGS		APPROVED SIZES		SCALE: N.T.S.		SIZE: A	
DESIGN (PSF):	+36.80/-41.60	MAX WIDTH:	16'-2"	DATE	03/09/21	NAME	JQ
TEST (PSF):	+55.20/-62.40	MAX HEIGHT:	24'-0"	DRAWN	03/31/21	CHECKED	DK
IMPACT/CYCLIC RATED (YES/NO): YES		MAX SECTION HEIGHT: 24"		SHEET 2 OF 2			
MODELS 5745/5765/7565/7655/515/525				DRAWING PART NO.			
WINDLOAD SPECIFICATION OPTION CODE 2611				411901			
				REV.			
				-			