

NOTES: (UNLESS OTHERWISE SPECIFIED)

1. RATED DESIGN LOAD +46/-52 PSF.
2. SECTION HEIGHTS MAY VARY TO CREATE VARIOUS DOOR HEIGHTS, 24" MAXIMUM SECTION HEIGHT.
3. MINIMUM 1" OVERLAP ON BOTH JAMBS REQUIRED TO MEET NEGATIVE DESIGN PRESSURES.
4. TESTED IN ACCORDANCE WITH DADE COUNTY PROTOCOLS TAS 201-94, TAS 202-94, & TAS 203-94.
5. DOOR SKIN MUST BE 50,000 PSI MIN. YIELD STRENGTH.
6. JAMB LOAD CALCULATIONS:
 $(1/2 \text{ DOOR WIDTH}) \times (1 \text{ FT OF HEIGHT}) \times (\text{DESIGN PRESSURE})$
 $(9.067) \times (1 \text{ FOOT}) \times (46.00 \text{ AND } -52.00) = (417.08 / -471.48) \text{ LB}$
7. JAMB FASTENER REQUIREMENTS:
 $F_y = (1/2 \text{ DOOR WIDTH}) \times (1 \text{ FT OF HEIGHT}) \times (\text{DESIGN PRESSURE})$
 $F_y = 417 \text{ LBS.}$
8. DOOR SKIN MATERIAL SHALL BE GALVANIZED ACCORDING TO ASTM A-525 TO G40 MIN, WITH BAKED-ON PRIMER, AND BAKED-ON POLYESTER PAINT TOP COAT.
9. FOR ANCHORING INTO WOOD, USE ONE 5/16" LAG SCREW PER TRACK BRACKET WITH 1-1/2" EMBEDMENT INTO SOUTHERN PINE (G=0.55) OR BETTER.
10. WELD SLOT ON ANGLE 3/32" X 1" LONG ON 12" CENTERS. "IF WELDING MOUNTING OPTION IS CHOSEN."
11. LIFT UP MECHANISM-MANUAL, CHAIN LIFT, OR OPERATOR IS NOT PART OF THIS APPROVAL.
12. STANDARD LIFT, HIGH LIFT, VERTICAL LIFT, AND LOW HEADROOM LIFT CONDITIONS TOP BRACKET SHALL BE 13 GA LHR 7/4 TOP BRACKET WITH A MIN OF
13. ATTACH STRUTS WITH (2) 1/4-14x7/8" SELF DRILLING CRIMP TITE SCREWS AT ALL HINGE LOCATIONS AND (2) BETWEEN EACH INTERMEDIATE HINGE. TYP. STRUT LOCATED AT TOP AND/ OR AT BOTTOM OF SECTION.
14. KEY LOCK, OR SIDE LOCK REQUIRED.
15. EXHAUST PORTS- OPTIONAL UP TO 3 PER BOTTOM SECTION.
16. IMPACT RESISTANT GLAZING OPTION- IMPACT RESISTANT GLAZING SYSTEM MAY AND BE INSTALLED IN TOP OR INTERMEDIATE SECTIONS. GLAZING SHALL BE 1/4" POLYCARBONATE. 14" X 46" MAXIMUM SIZE, FASTENED WITH # 8 X 1" SMS; 5X MAX ALONG THE HORIZONTAL AND 3X MAX ALONG THE VERTICAL. SEE DETAIL F-F ON SHEET 2 FOR ASSEMBLY DETAILS.
17. THE DESIGN OF THE SUPPORTING STRUCTURAL ELEMENTS SHALL BE THE RESPONSIBILITY OF THE PROFESSIONAL OF RECORD FOR THE BUILDING OR STRUCTURE AND IN ACCORDANCE WITH CURRENT BUILDING CODES FOR THE LOADS LISTED ON THIS DRAWING.
18. LOUVER OPTION - LOUVERS MAY BE INSTALLED IN DOOR IF THE AREA OF EACH LOUVER DOES NOT EXCEED 60 IN. DOOR VENTS LARGER THAN 60 IN MUST BE TESTED FOR IMPACT.
19. A 4-1/2" X 6" X 22 GA BACKER PLATE IS TO BE LOCATED AT EVERY INTERMEDIATE AND OUTER END HINGE LOCATIONS.

THE DOORS ARE DESIGNED AND MANUFACTURED TO COMPLY WITH THE 2018 IRC AND THE 2018 IBC.

REVISIONS				
ER	REV	DESCRIPTION	DATE	APVL
ER	P00	NEW DRAWING	8/28/18	ESC
32442	A	ADDED IRC/IBC NOTE	8/28/20	TLC

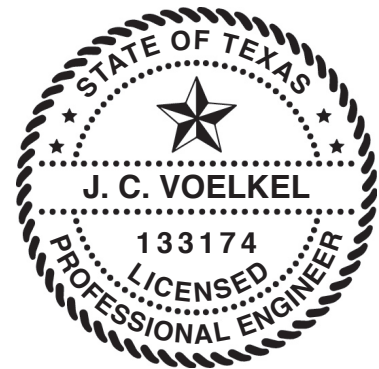
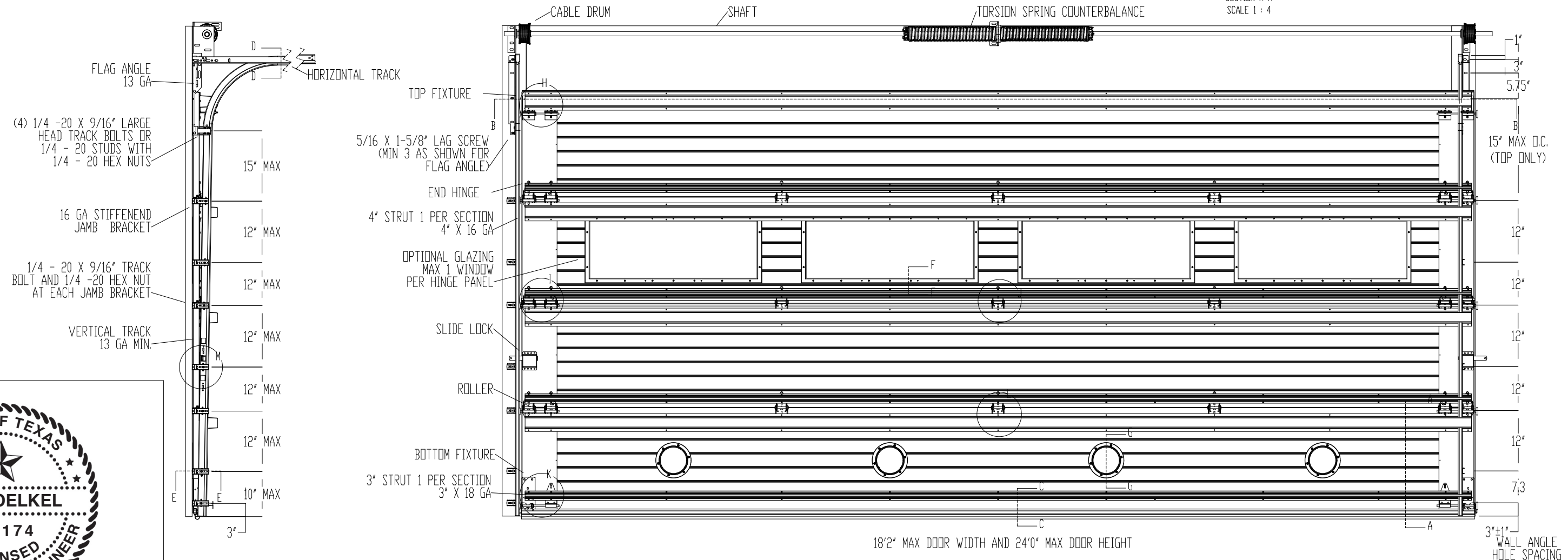
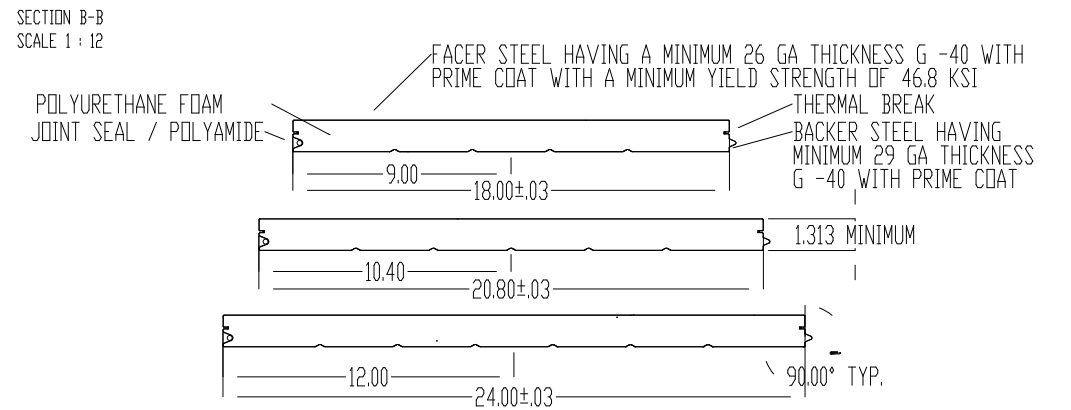
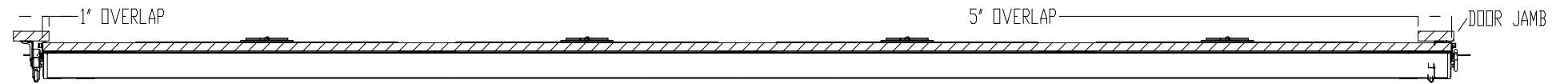

J. CHRISTIAN VOELKEL, PE
 312 N. NEW WARRINGTON ROAD, UNIT 1A
 PENSACOLA, FL
 FL PE 82229 TX PE 133174
 PROFESSIONAL ENGINEER'S SEAL PROVIDED ONLY FOR VERIFICATION OF WINDLOAD CONSTRUCTION DETAILS.

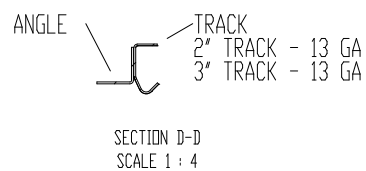
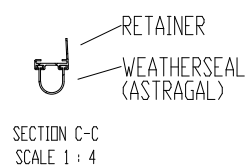

THIRD ANGLE PROJECTION 	UNLESS OTHERWISE SPECIFIED INTERPRET DIMS & TOLS PER ASME Y14.5M ALL DIMS ARE IN INCHES DO NOT SCALE DIMS CIRCLED WITH SYMBOL 'Ø' ARE CRITICAL TO QUALITY DESIGN FEATURES & MUST MEET APPLICABLE IN-PROCESS INSPECTION STANDARDS.	TOLERANCES: .X = ±.1 .XX = ±.03 .XXX = ±.010 ANGULAR = ±.5° HOLES: < Ø.251 = +.004/-0.03 Ø.251-Ø.500 = +.006/-0.03 > Ø.500 = +.008/-0.03 ALL GEOMETRY GOVERNED BY 3D CAD DATABASE: 8300 WL FLUSH COMPLETE DOOR	APPROVALS DATE DRAWN E. CONRAD 8/28/18 CHECKED D. KORNISH - APPROVED - - MATERIAL - - FINISH - -	LEWISVILLE, TEXAS DESCRIPTION WINDLOAD MODELS 4600/4650/5745/5765/7565/515/525/850, +46/-52PSF DADE COUNTY, 18'2" MAX WIDTH
			SIZE DWG NO. D D-411531	REV A

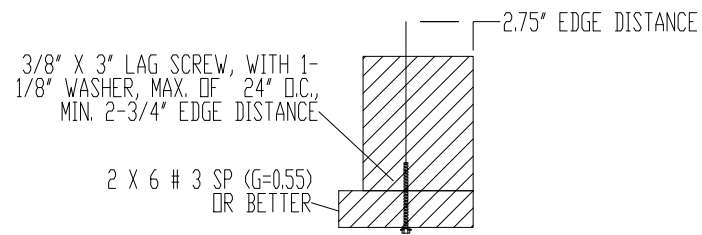

WOOD MOUNTED TO # 3 SOUTHERN PINE SUBSTRATE

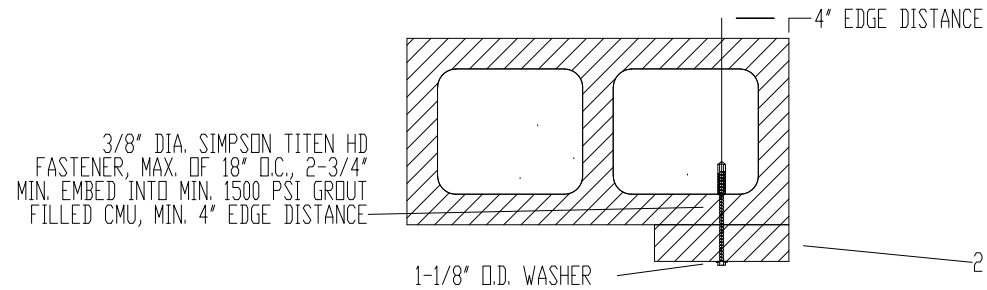

WOOD MOUNTED TO GROUT FILLED MASONRY BLOCK DETAIL

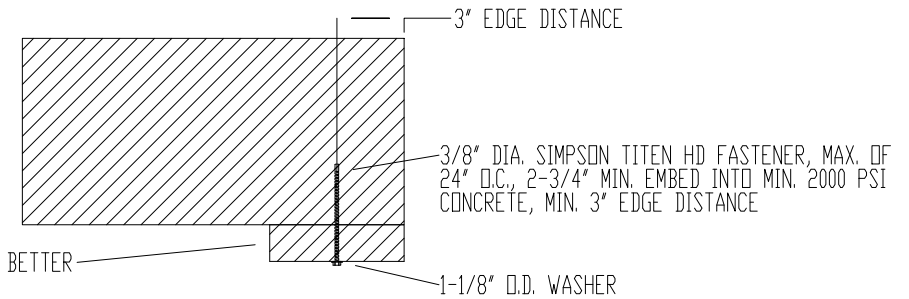

WOOD MOUNTED TO 2000 PSI CONCRETE DETAIL

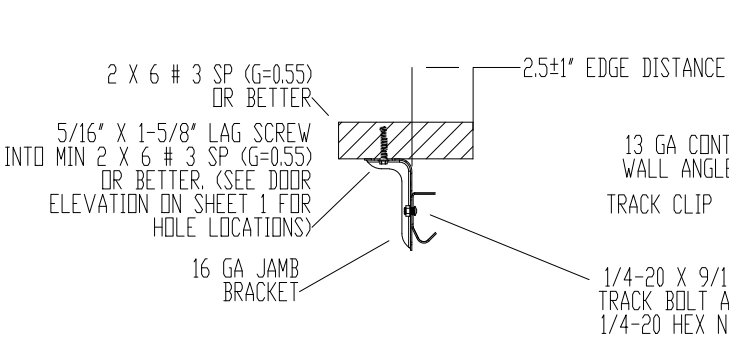

MOUNTING TO WOOD JAMB DETAIL

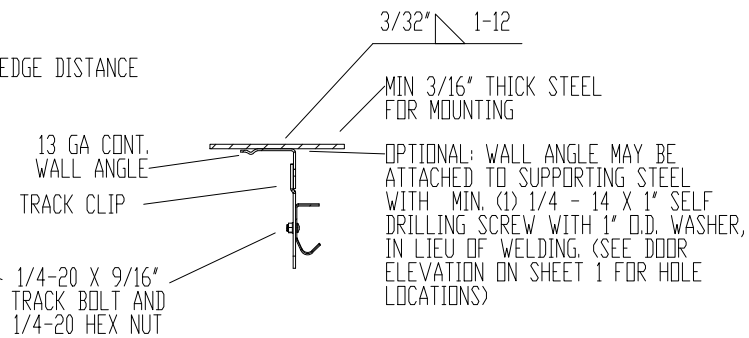

MOUNTING TO STEEL JAMB DETAIL

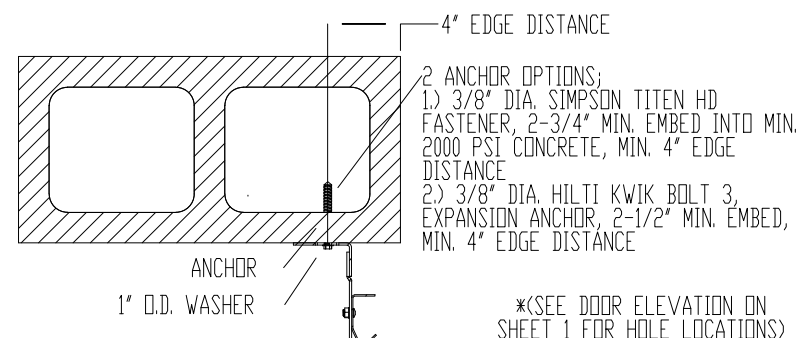

MOUNTING TO GROUT FILLED MASONRY BLOCK DETAIL

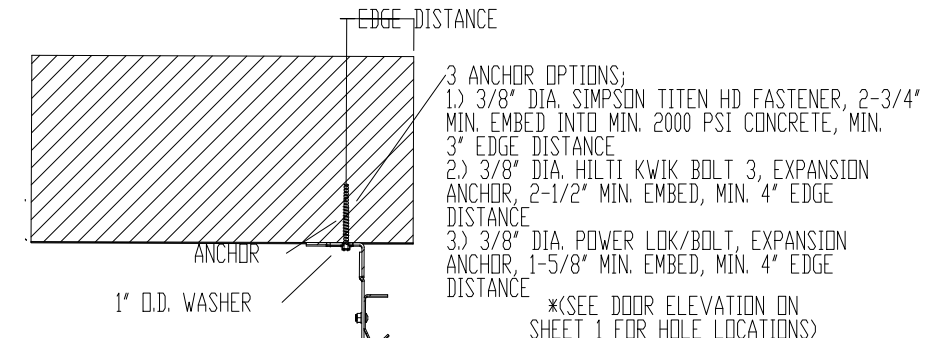

MOUNTING TO 2000 PSI CONCRETE DETAIL

SECTION E-E
SCALE 1:4

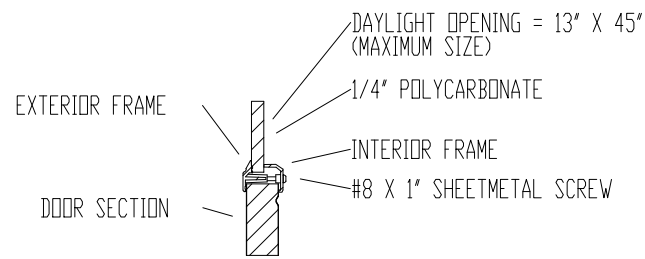

WINDOW DETAIL

SECTION F-F
SCALE 1:4

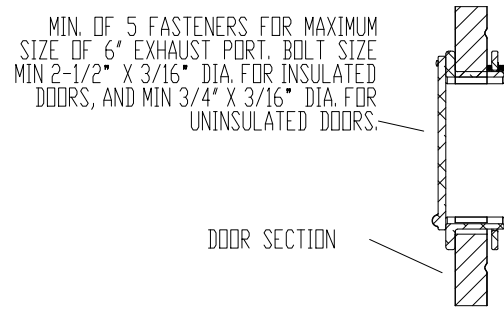

EXHAUST PORT DETAIL

SECTION G-G
SCALE 1:4

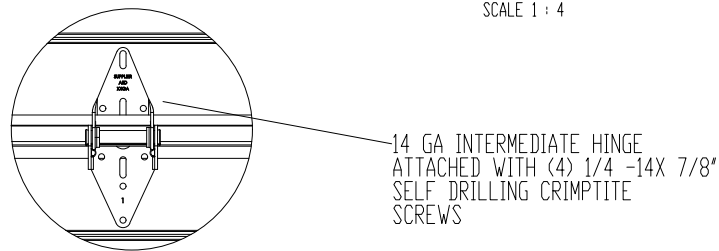

DETAIL J
SCALE 1:4

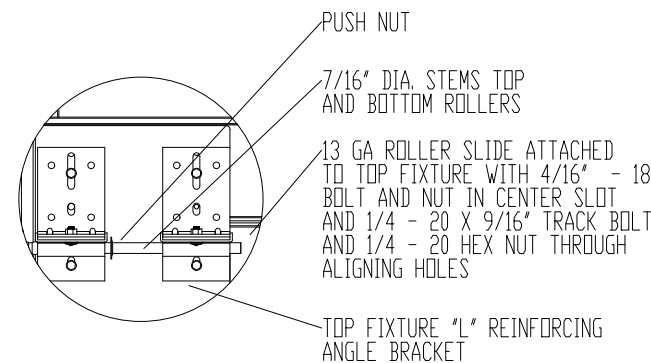

DETAIL H
SCALE 1:4

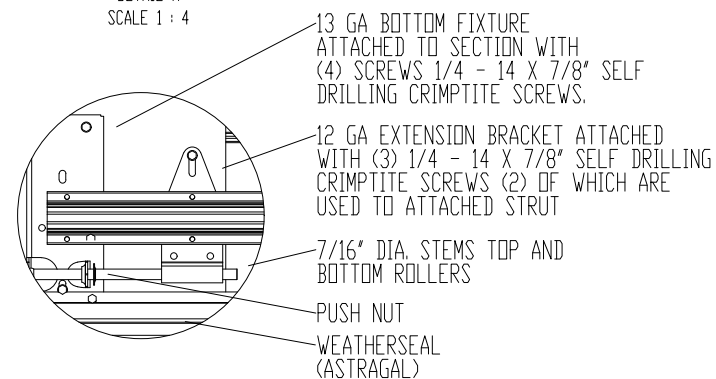

DETAIL K
SCALE 1:4

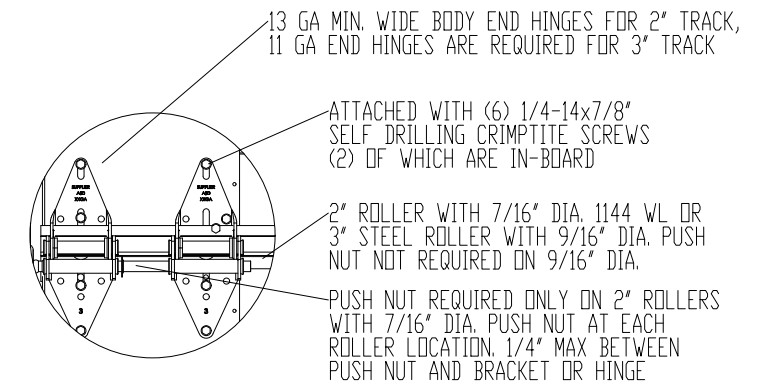

DETAIL I
SCALE 1:4

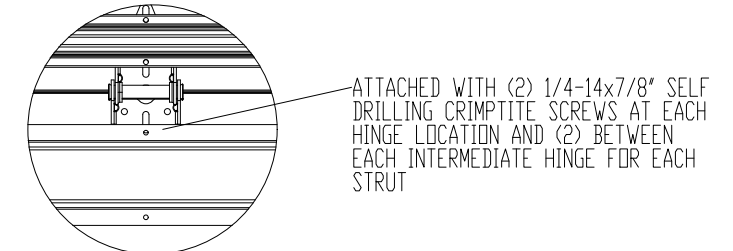

DETAIL L
SCALE 1:4

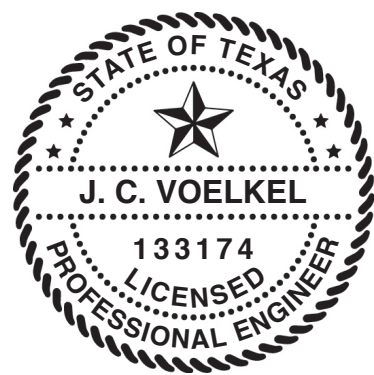

J. CHRISTIAN VOELKEL, PE
312 N. NEW WARRINGTON ROAD, UNIT 1A
PENSACOLA, FL
FL PE 82229 TX PE 133174
PROFESSIONAL ENGINEER'S SEAL PROVIDED ONLY FOR
VERIFICATION OF WINDLOAD CONSTRUCTION DETAILS.

THIRD ANGLE PROJECTION		UNLESS OTHERWISE SPECIFIED		APPROVALS		DATE	DESCRIPTION	
	INTERPRET DIMS & TOLS PER ASME Y14.5M ALL DIMS ARE IN INCHES DO NOT SCALE DIMS CIRCLED WITH SYMBOL 'O' ARE CRITICAL TO QUALITY DESIGN FEATURES & MUST MEET APPLICABLE IN-PROCESS INSPECTION STANDARDS.	TOLERANCES: .X = ±.1 .XX = ±.03 .XXX = ±.010 ANGULAR = ±.5° HOLES: $\varnothing .251 = +.004 / -.003$ $\varnothing .251 - \varnothing .500 = +.006 / -.003$ $> \varnothing .500 = +.008 / -.003$	DRAWN E. CONRAD CHECKED D. KORNISH APPROVED - MATERIAL - FINISH -	DATE 8/28/18 - - -	LEWISVILLE, TEXAS DESCRIPTION WINDLOAD MODELS 4600/4650/5745/5765/ 7565/515/525/850, +46/-52PSF DADE COUNTY, 18'2" MAX WIDTH	SIZE DWG NO. D-411531	REV A	
	OVERHEAD DOOR CORP 2501 S. STATE HWY 121 SUITE 200 LEWISVILLE, TEXAS 75067 469-549-7100	ALL GEOMETRY GOVERNED BY 3D CAD DATABASE: 8300 WL FLUSH COMPLETE DOOR	SCALE 1:12	UOM = EA	SHEET 2 OF 4	1	2	3

NOTES: (UNLESS OTHERWISE SPECIFIED)

1. ONE 4" AND 3" STRUT PER SECTION, ATTACHED WITH 1/4-14X7/8" SELF DRILLING CRIMPTITE SCREWS.

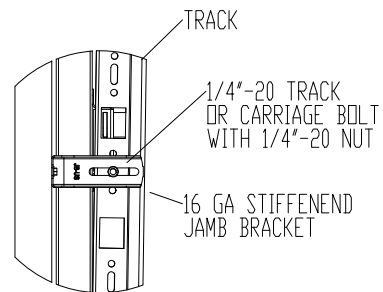

TYPICAL TRACK AND JAMB FASTENERS DETAIL

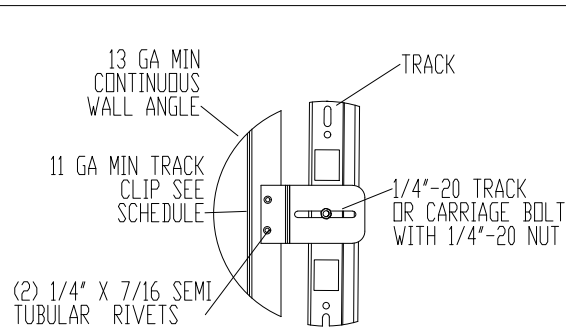

TYPICAL TRACK CLIP RIVETING DETAIL

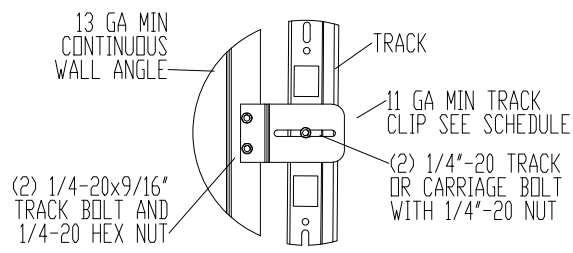

TYPICAL TRACK CLIP BOLTING DETAIL

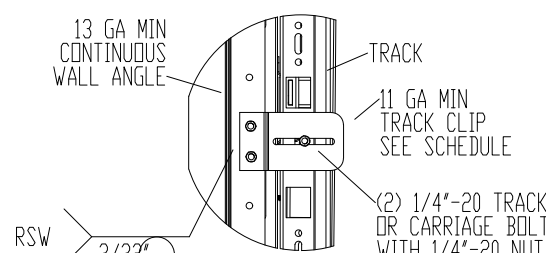

TYPICAL TRACK CLIP WELDING DETAIL

OPTIONAL WALL ANGLE TRACK

DETAIL M SCALE 1:4

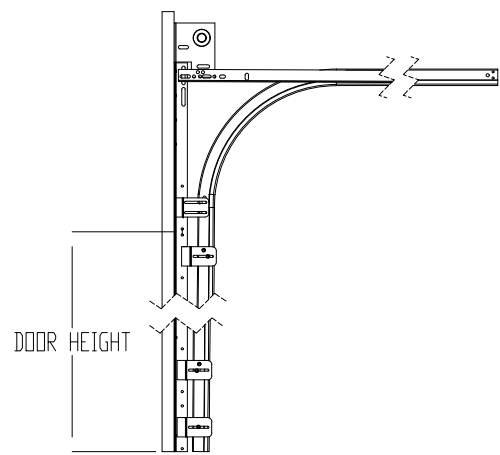

STANDARD LIFT TRACK DETAIL

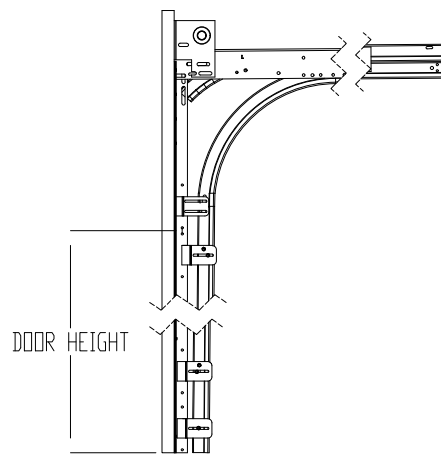

LOW HEADROOM TRACK DETAIL

TRACK DETAIL SCALE 1:12

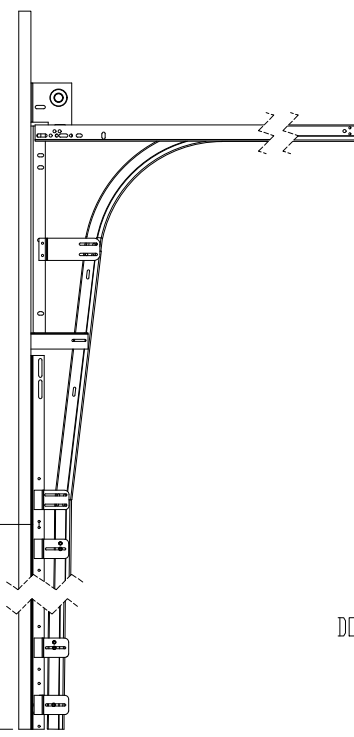

HIGH LIFT TRACK DETAIL

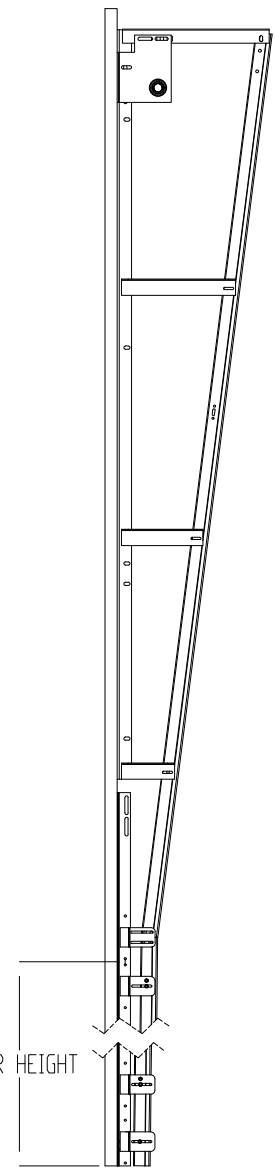

VERTICAL LIFT TRACK DETAIL

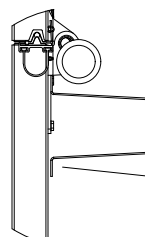

DETAIL N SCALE 1:4

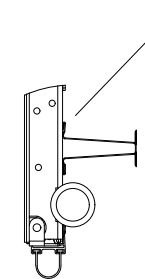

DETAIL D SCALE 1:4

4' STRUT ATTACHED WITH (2) 1/4-14X7/8" SELF DRILLING CRIMPTITE SCREWS AT EACH HINGE LOCATION AND (2) BETWEEN EACH INTERMEDIATE HINGE FOR EACH STRUT

3' STRUT ATTACHED WITH (2) 1/4-14X7/8" SELF DRILLING CRIMPTITE SCREWS AT EACH HINGE LOCATION AND (2) BETWEEN EACH INTERMEDIATE HINGE FOR EACH STRUT

(7) SECTION DOORS WITH (7) 4" 16 GA 80 KSI U- BARS (7) 3" 18 GA 80 KSI U- BARS LOCATED AS SHOWN

(6) SECTION DOORS WITH (6) 4" 16 GA 80 KSI U- BARS (6) 3" 18 GA 80 KSI U- BARS LOCATED AS SHOWN

(5) SECTION DOORS WITH (5) 4" 16 GA 80 KSI U- BARS (5) 3" 18 GA 80 KSI U- BARS LOCATED AS SHOWN

(4) SECTION DOORS WITH (4) 4" 16 GA 80 KSI U- BARS (4) 3" 18 GA 80 KSI U- BARS LOCATED AS SHOWN

(9) SECTION DOORS WITH (9) 4" 16 GA 80 KSI U- BARS (9) 3" 18 GA 80 KSI U- BARS LOCATED AS SHOWN

(8) SECTION DOORS WITH (8) 4" 16 GA 80 KSI U- BARS (8) 3" 18 GA 80 KSI U- BARS LOCATED AS SHOWN

(10) SECTION DOORS WITH (10) 4" 16 GA 80 KSI U- BARS (10) 3" 18 GA 80 KSI U- BARS LOCATED AS SHOWN

(11) SECTION DOORS WITH (11) 4" 16 GA 80 KSI U- BARS (11) 3" 18 GA 80 KSI U- BARS LOCATED AS SHOWN

(12) SECTION DOORS WITH (12) 4" 16 GA 80 KSI U- BARS (12) 3" 18 GA 80 KSI U- BARS LOCATED AS SHOWN

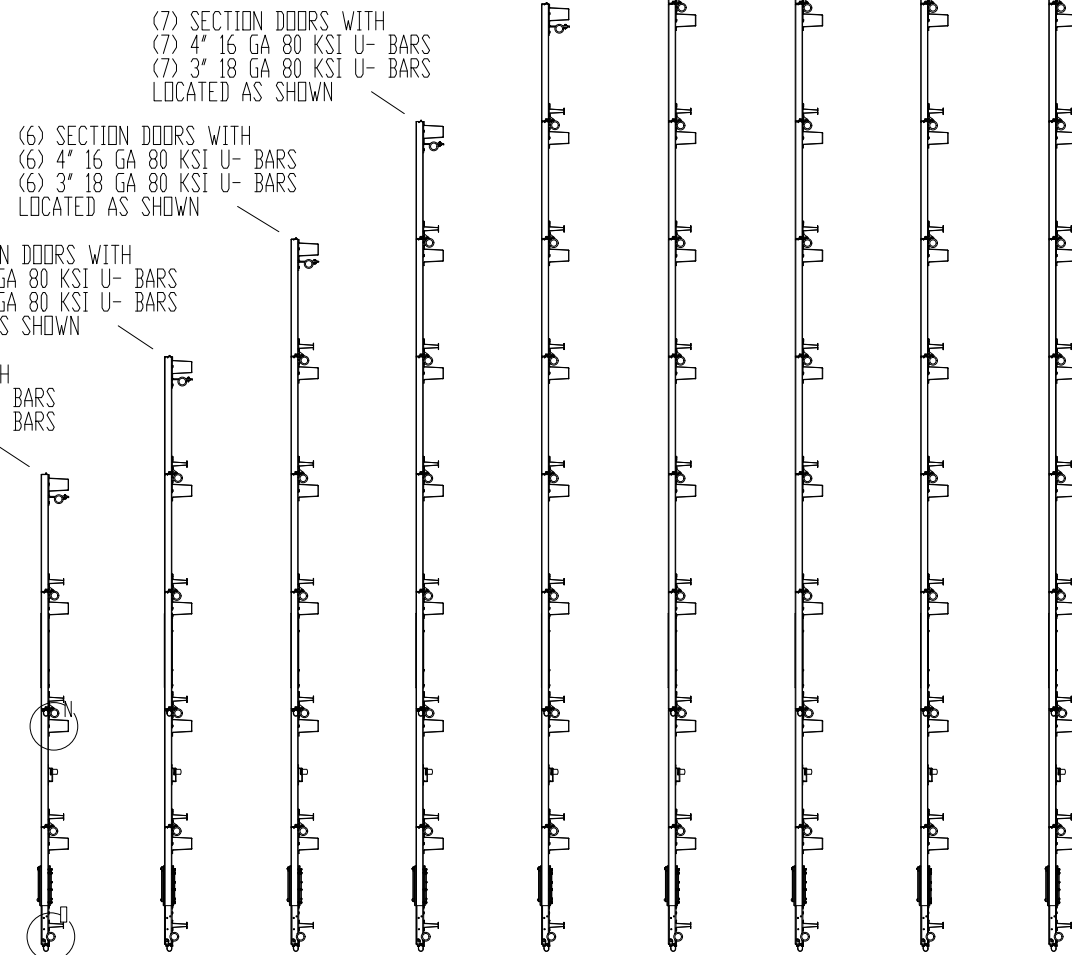

STRUT LOCATIONS SCALE 1:20

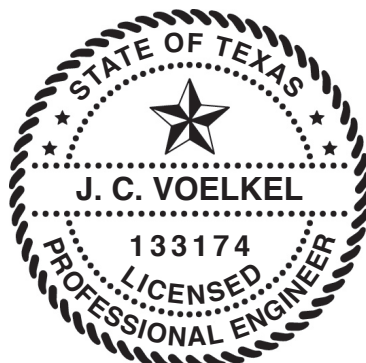

J. CHRISTIAN VOELKEL, PE
312 N. NEW WARRINGTON ROAD, UNIT 1A
PENSACOLA, FL
FL PE 82229 TX PE 133174
PROFESSIONAL ENGINEER'S SEAL PROVIDED ONLY FOR VERIFICATION OF WINDLOAD CONSTRUCTION DETAILS.

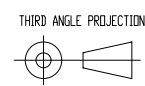

OVERHEAD DOOR CORP
2501 S. STATE HWY 121
SUITE 200
LEWISVILLE, TEXAS 75067
469-549-7100

UNLESS OTHERWISE SPECIFIED
INTERPRET DIMS & TOLS PER ASME Y14.5M
ALL DIMS ARE IN INCHES
DO NOT SCALE
DIMS CIRCLED WITH SYMBOL 'O' ARE CRITICAL TO QUALITY DESIGN FEATURES & MUST MEET APPLICABLE IN-PROCESS INSPECTION STANDARDS.

TOLERANCES:
.X = ±.1
.XX = ±.03
.XXX = ±.010
ANGULAR = ±.5°
HOLES:
< 0.251 = +.004/-0.003
0.251-0.500 = +.006/-0.003
> 0.500 = +.008/-0.003
ALL GEOMETRY GOVERNED BY 3D CAD DATABASE:
8300 WL FLUSH COMPLETE DOOR

APPROVALS		DATE
DRAWN	E. CONRAD	8/28/18
CHECKED	D. KORNISH	-
APPROVED	-	-
MATERIAL	-	-
FINISH	-	-

DESCRIPTION		
WINDLOAD MODELS 4600/4650/5745/5765/7565/515/525/850, +46/-52PSF DADE COUNTY, 18'2" MAX WIDTH		
SIZE	DWG NO.	REV
D	D-411531	A
SCALE 1:12	UOM = EA	SHEET 3 OF 4

NOTES: (UNLESS OTHERWISE SPECIFIED)
 1. FOR DIMENSIONS AND NOTE REFERENCES, REFER TO INDIVIDUAL DRAWINGS.

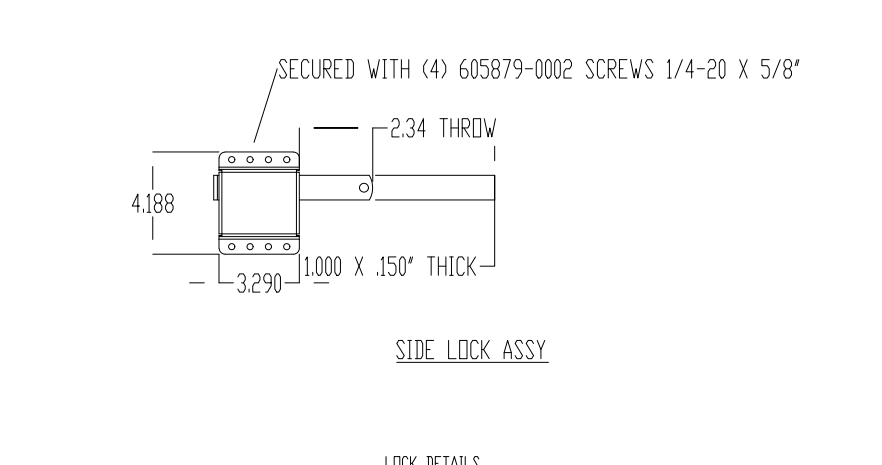
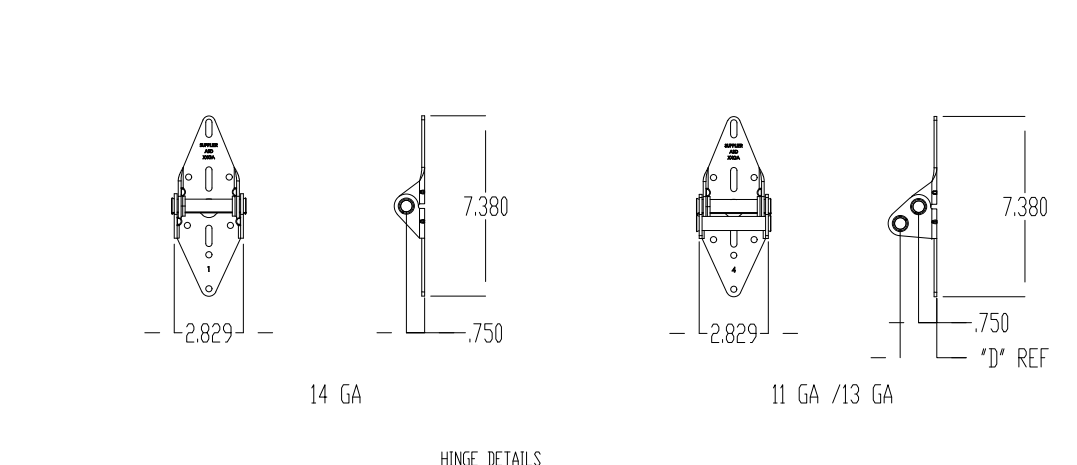
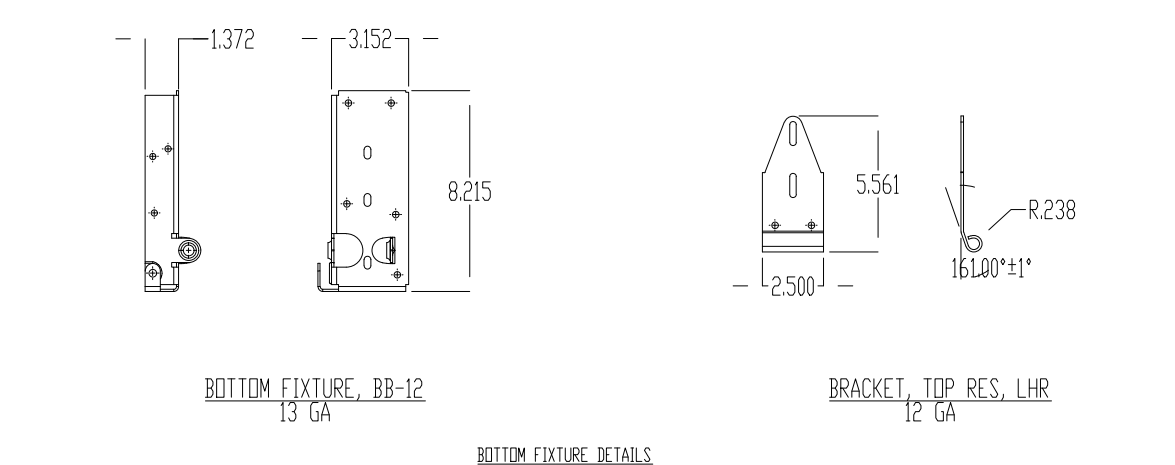
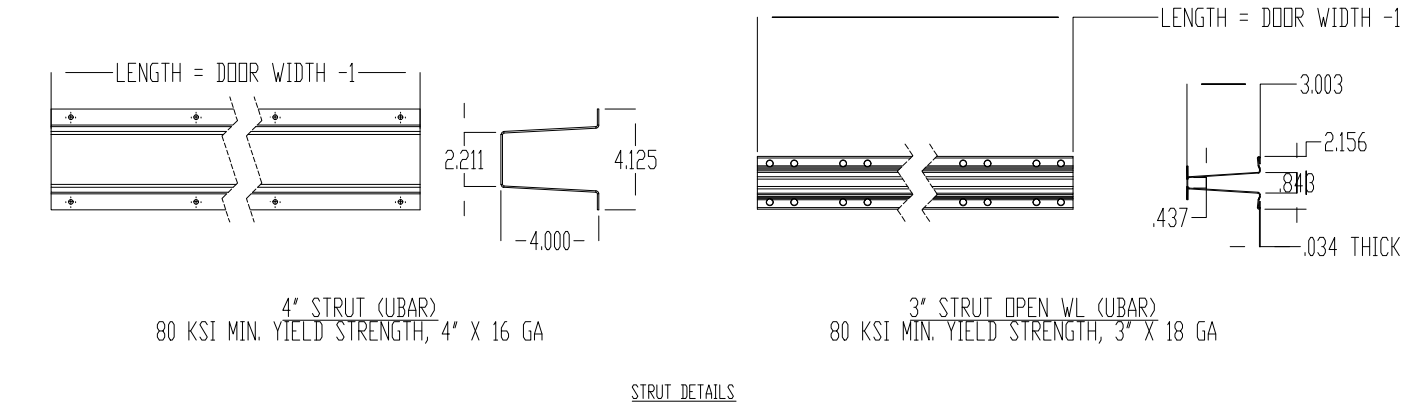
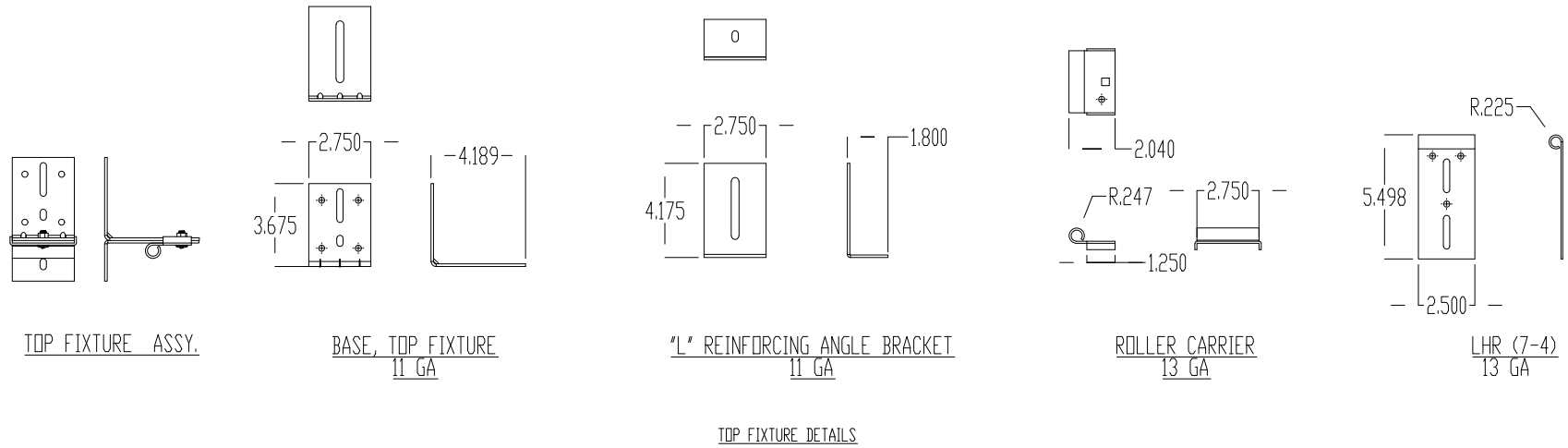

J. CHRISTIAN VOELKEL, PE
 312 N. NEW WARRINGTON ROAD, UNIT 1A
 PENSACOLA, FL
 FL PE 82229 TX PE 133174
 PROFESSIONAL ENGINEER'S SEAL PROVIDED ONLY FOR
 VERIFICATION OF WINDLOAD CONSTRUCTION DETAILS.

	UNLESS OTHERWISE SPECIFIED INTERPRET DIMS & TOLS PER ASME Y14.5M ALL DIMS ARE IN INCHES DO NOT SCALE DIMS CIRCLED WITH SYMBOL 'C' / ARE CRITICAL TO QUALITY DESIGN FEATURES & MUST MEET APPLICABLE IN-PROCESS INSPECTION STANDARDS.	TOLERANCES: .X = ±.1 .XX = ±.03 .XXX = ±.010 ANGULAR = ±.5° HOLES: $\varnothing .251 = +.004 / -.003$ $\varnothing .251 - \varnothing .500 = +.006 / -.003$ $> \varnothing .500 = +.008 / -.003$	APPROVALS DATE DRAWN E. CONRAD 8/28/18 CHECKED D. KORNISH - APPROVED - - MATERIAL - - FINISH - -	LEWISVILLE, TEXAS DESCRIPTION WINDLOAD MODELS 4600/4650/5745/5765/ 7565/515/525/850, +46/-52PSF DADE COUNTY, 18'2" MAX WIDTH	SIZE DWG NO. D D-411531	REV A
			ALL GEOMETRY GOVERNED BY 3D CAD DATABASE: 8300 WL FLUSH COMPLETE DOOR	SCALE 1:12 UOM = SHEET 4 OF 4		