

L'TR	REVISION	DATE	BY	E.C.O.
*	ORIGINAL ISSUE	11/20/14	TJE	1616
A	REVISED AVAILABLE CONFIGURATIONS	04/27/16	TJE	1616
B	REVISED MAXIMUM HEIGHT NOTE	08/10/16	TJE	1616
C	HOOD SUPPORT UPDATE; 2018 IBC	03/09/20	MAN	2028

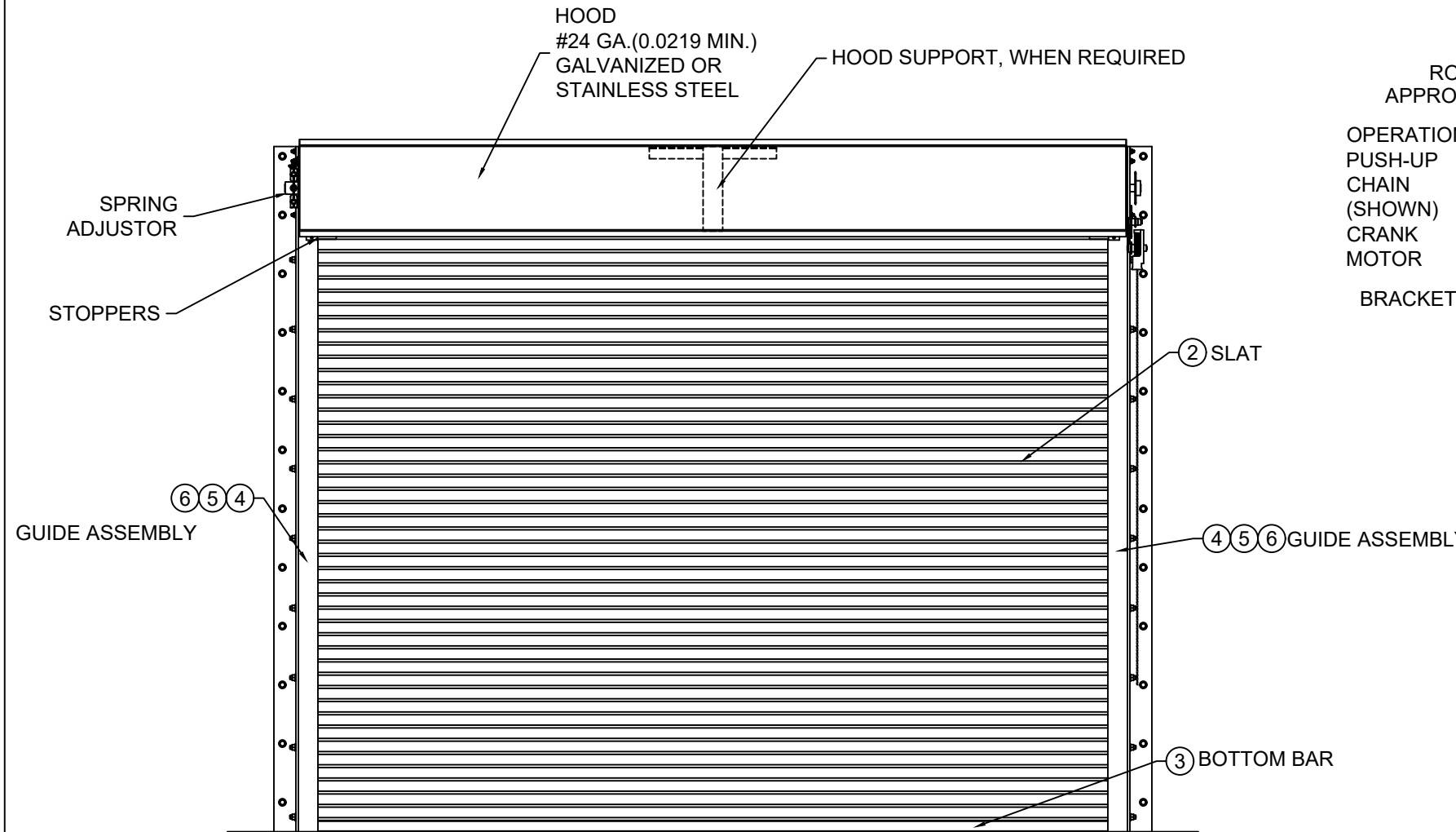

ROLL-UP MECHANISM NOT INCLUDED IN THIS APPROVAL. MUST BE CERTIFIED BY AN INDEPENDENT TESTING AGENCY IF REQUIRED.

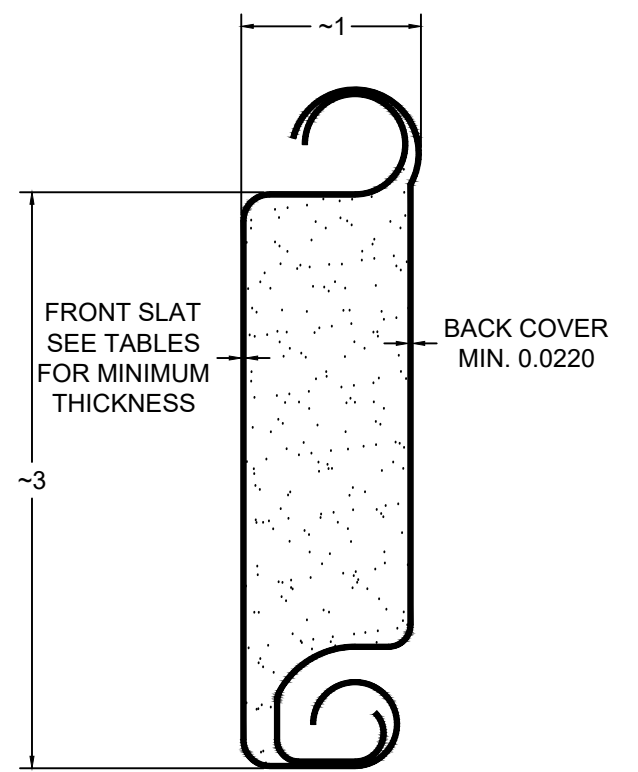
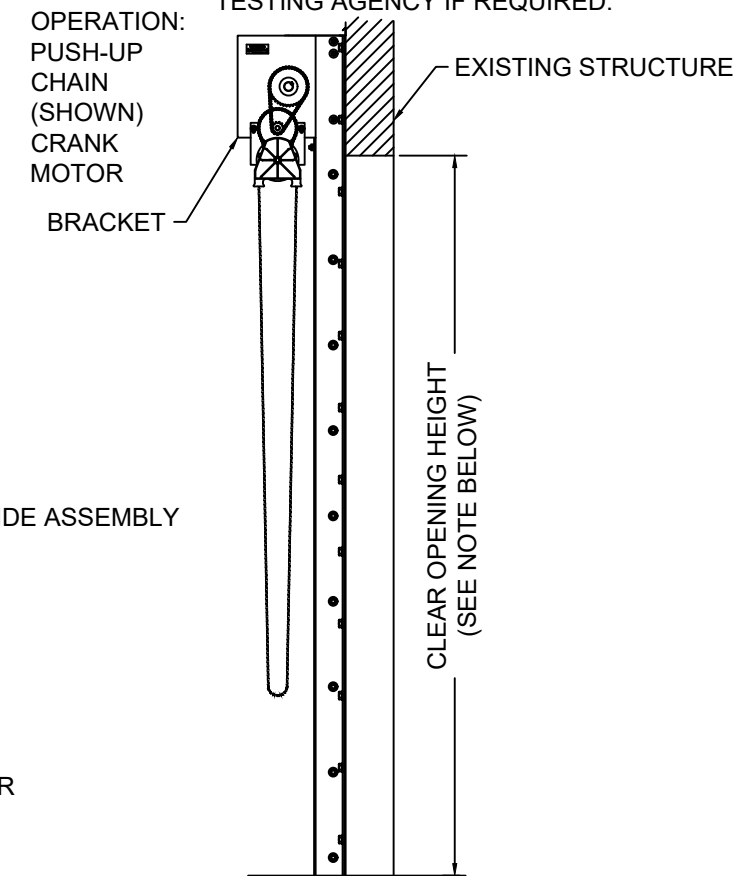

② SLAT DETAIL TYPICAL SECTION

ASTM A653 HSLAS TYPE B GRADE 40 G40 OR  
 ASTM A653 HSLAS TYPE A GRADE 40 G40 OR  
 ASTM A653 STRUCTURAL STEEL GRADE 40 G40  
 OR TYPE 304 STAINLESS STEEL (MIN. YIELD 40,000 psi)  
 OR TYPE 316 STAINLESS STEEL (MIN. YIELD 40,000 psi)  
 OR TYPE 430 STAINLESS STEEL (MIN. YIELD 40,000 psi)  
 OR TYPE 201 STAINLESS STEEL (MIN. YIELD 40,000 psi)  
 FULL SCALE

NOTE: WIND LOADS SPECIFIED IN TABLES ARE ACCEPTABLE FOR ANY C.O.H. UP TO 30'-0"

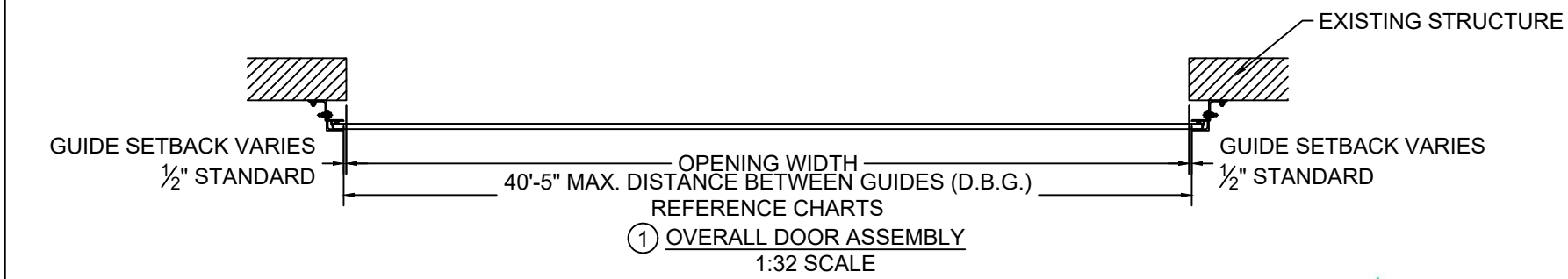

① OVERALL DOOR ASSEMBLY 1:32 SCALE



CLOPAY CORPORATION  
 8585 DUKE BOULEVARD  
 MASON, OH 45040

P: 800.225.6729  
 F: 513.440.4853

Unless otherwise specified, dimensions are in inches & tolerances are:

0.000 = +/- 0.031  
 FRACTIONAL = +/- 1/32  
 ANGLES = +/- 1/2 DEG

TITLE: WIND LOAD CONFIGURATION INSULATED ROLLING STEEL DOOR CP0001/CP0651 SLAT NON-IMPACT RATED	DRAWN BY: TJE	SIZE: B	SCALE: AS NOTED	SHEET: 1/8
	DWG NO: ES-16-71-CLO			

L'TR	REVISION	DATE	BY	E.C.O.
*	ORIGINAL ISSUE	11/20/14	TJE	1616
A	REVISED AVAILABLE CONFIGURATIONS	04/27/16	TJE	1616
B	REVISED MAXIMUM HEIGHT NOTE	08/10/16	TJE	1616
C	HOOD SUPPORT UPDATE; 2018 IBC	03/09/20	MAN	2028

**GENERAL NOTES:**

1. THESE PRODUCT EVALUATION DOCUMENTS REPRESENT A ROLL-UP DOOR ASSEMBLY DESIGNED AND TESTED IN ACCORDANCE WITH THE STANDARD BUILDING CODE, THE 2018 INTERNATIONAL BUILDING CODE, AND THE FLORIDA BUILDING CODE.
2. THIS ROLL-UP DOOR HAS BEEN TESTED FOR UNIFORM STATIC PRESSURE IN ACCORDANCE WITH THE FBC TEST PROTOCOLS TAS 202.
3. A 33% INCREASE IN ALLOWABLE STRESS HAS NOT BEEN USED IN THE DESIGN OF THIS PRODUCT.
4. DETERMINE THE POSITIVE AND NEGATIVE DESIGN LOADS TO USE WHEN REFERENCING THESE DOCUMENTS IN ACCORDANCE WITH THE GOVERNING CODE AND GOVERNING WIND VELOCITY.
5. THESE PRODUCT EVALUATION DOCUMENTS ARE PREPARED BY THE PRODUCT ENGINEER AND ARE GENERIC. THEY DO NOT INCLUDE INFORMATION PREPARED FOR A SPECIFIC SITE.
6. THESE PRODUCT EVALUATION DOCUMENTS ARE NOT VALID FOR PERMIT WITHOUT ORIGINAL SIGNATURE, DATE AND EMBOSSED SEAL ON EACH PERMIT COPY, WHETHER OR NOT A MASTER APPROVAL DOCUMENT IS ON FILE WITH A MUNICIPALITY OR OTHER GOVERNING AGENCY.
7. THESE PRODUCT EVALUATION DOCUMENTS ARE SUITABLE TO BE APPLIED BY THE CONTRACTOR PROVIDED THE CONTRACTOR DOES NOT DEVIATE FROM THE CONDITIONS DETAILED HEREIN AND THE CONTRACTOR VERIFIES THE EXISTING STRUCTURE IS CAPABLE OF SUPPORTING THE SUPERIMPOSED LOADS  $V_x$  &  $V_y$  ON THE JAMBS OF THE DOOR.
8. ALTERATIONS OR ADDITIONS TO THIS DOCUMENT ARE NOT PERMITTED.
9. WHEN THE SITE CONDITIONS DEVIATE FROM THESE PRODUCT EVALUATION DOCUMENTS, SITE SPECIFIC DOCUMENTS SHALL BE PREPARED BY A DULY LICENSED AND REGISTERED ENGINEER OR ARCHITECT.
10. IF THE DEVIATING SITE SPECIFIC DOCUMENTS ARE PREPARED BY A DELEGATED REGISTERED ENGINEER OR ARCHITECT, SAID DOCUMENTS SHALL BEAR THE DATE, SIGNATURE, AND EMBOSSED SEAL OF THE DELEGATED ENGINEER OR ARCHITECT AND SHALL BE SUBMITTED TO THE PROJECT ENGINEER FOR REVIEW.
11. ALL BOLTS AND WASHERS SHALL BE GALVANIZED STEEL, PLATED STEEL, OR STAINLESS STEEL
12. ALL WINDLOCK RIVETS SHALL BE 1/4" STEEL RIVETS IFI GRADE 30 WITH A MINIMUM TENSILE STRENGTH OF 1,850 Lbs., AND SHEAR STRENGTH OF 2,400 Lbs., U.O.N.. RIVETS TO BE INSTALLED IN ALL WINDLOCK HOLES.
13. ENDLOCKS/WINDLOCKS SHALL BE CAST MALLEABLE IRON TYPE 32510 PER ASTM A47 OR CAST DUCTILE IRON PER ASTM A536 GRADE 65-45-12.
14. ALL WELDING SHALL BE PERFORMED BY QUALIFIED WELDERS IN ACCORDANCE WITH A.W.S. SPECIFICATIONS, LATEST EDITION. ALL WELDING ELECTRODES SHALL CONFORM TO A.W.S. A5.1 GRADE E-70. MINIMUM WELDING PROCESSES SHALL BE ARC WELDING A.W.S. E7014 OR MIG WELDING A.W.S. ER70S-6.
15. ANCHOR NOTES:  
 A. EMBEDMENT LENGTH DOES NOT INCLUDE STUCCO FINISH.  
 B. ANCHORS SHALL BE INSTALLED IN ACCORDANCE WITH MANUFACTURERS SPECIFICATIONS.  
 C. ANCHOR CAPACITY FOR THIS ROLL-UP DOOR IS BASED ON MIN. 3,000 P.S.I. CONCRETE EXCEPT WHERE NOTED..  
 D. FOR MINIMUM EMBEDMENT AND MINIMUM EDGE DISTANCE, REFER TO TABLES.
16. DOOR MAY BE INSTALLED ON THE INSIDE OR OUTSIDE OF AN EXTERIOR WALL
17. ALL SHAPES USED FOR GUIDE ASSEMBLIES MUST CONFORM TO ASTM A36 FOR STEEL OR ASTM A276 FOR TYPES 304 OR 316 WITH A MINIMUM 36 KSI YIELD STRENGTH

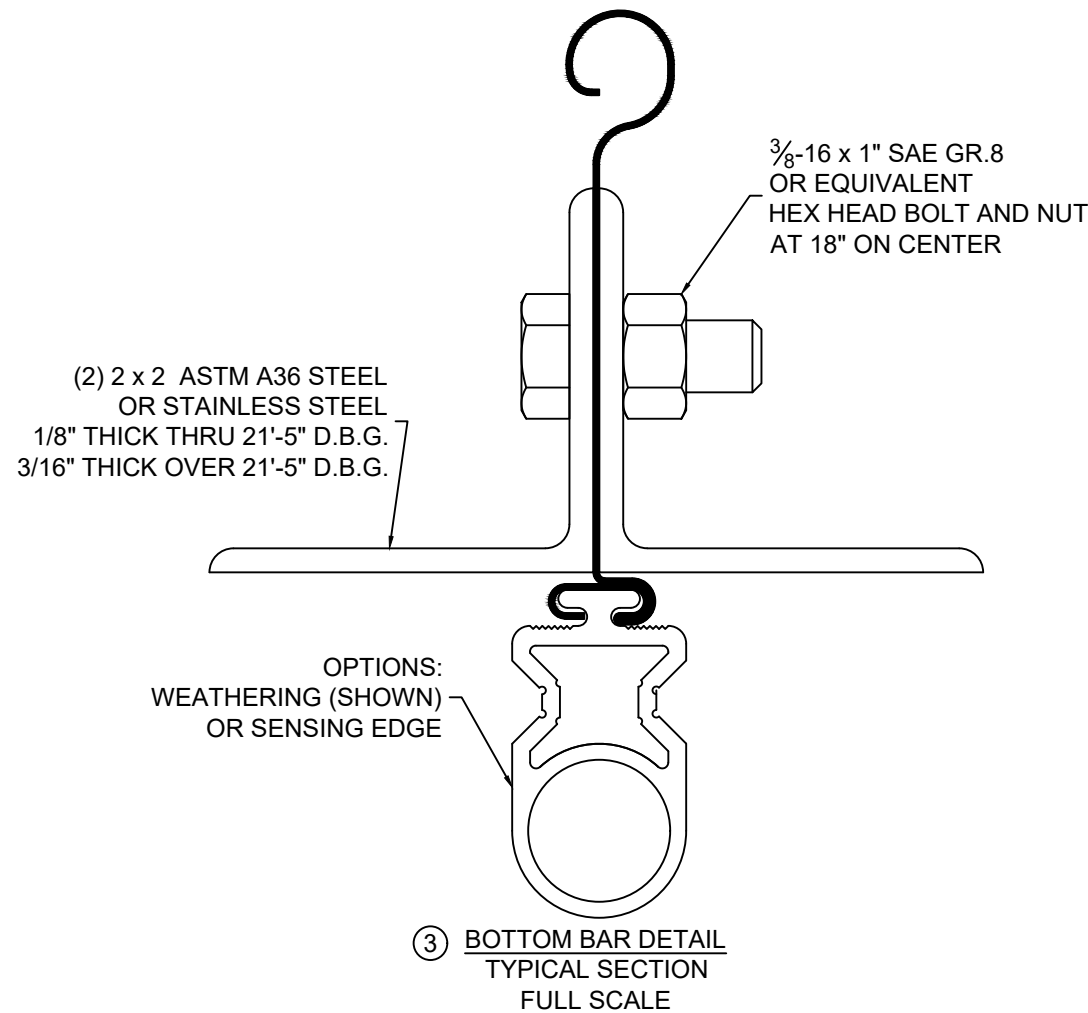

	CLOPAY CORPORATION 8585 DUKE BOULEVARD MASON, OH 45040		Unless otherwise specified, dimensions are in inches & tolerances are:  0.000 = +/- 0.031 FRACTIONAL = +/- 1/32 ANGLES = +/- 1/2 DEG	
	P: 800.225.6729 F: 513.440.4853		TITLE: WIND LOAD CONFIGURATION INSULATED ROLLING STEEL DOOR CP0001/CP0651 SLAT NON-IMPACT RATED	DRAWN BY: TJE SIZE: B SCALE: AS NOTED SHEET: 2/8
DWG NO: ES-16-71-CLO				

L'TR	REVISION	DATE	BY	E.C.O.
*	ORIGINAL ISSUE	11/20/14	TJE	1616
A	REVISED AVAILABLE CONFIGURATIONS	04/27/16	TJE	1616
B	REVISED MAXIMUM HEIGHT NOTE	08/10/16	TJE	1616
C	HOOD SUPPORT UPDATE; 2018 IBC	03/09/20	MAN	2028

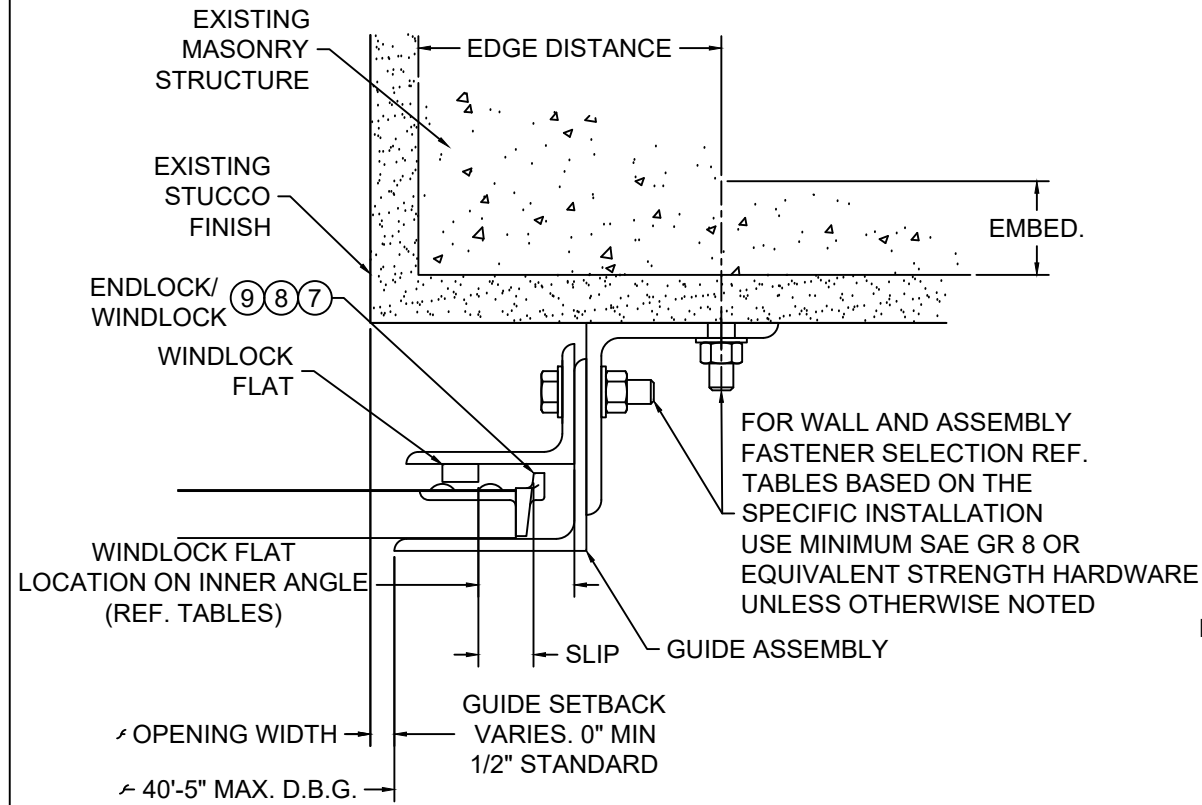

NOTE:  
THROUGH BOLTING TO FILLED BLOCK REQUIRES THE USE OF 1/4" THICK STEEL OR STAINLESS STEEL CRUSH PLATE

⑤ GUIDE ASSEMBLY  
CONCRETE & MASONRY STRUCTURE  
(Z-GUIDE)

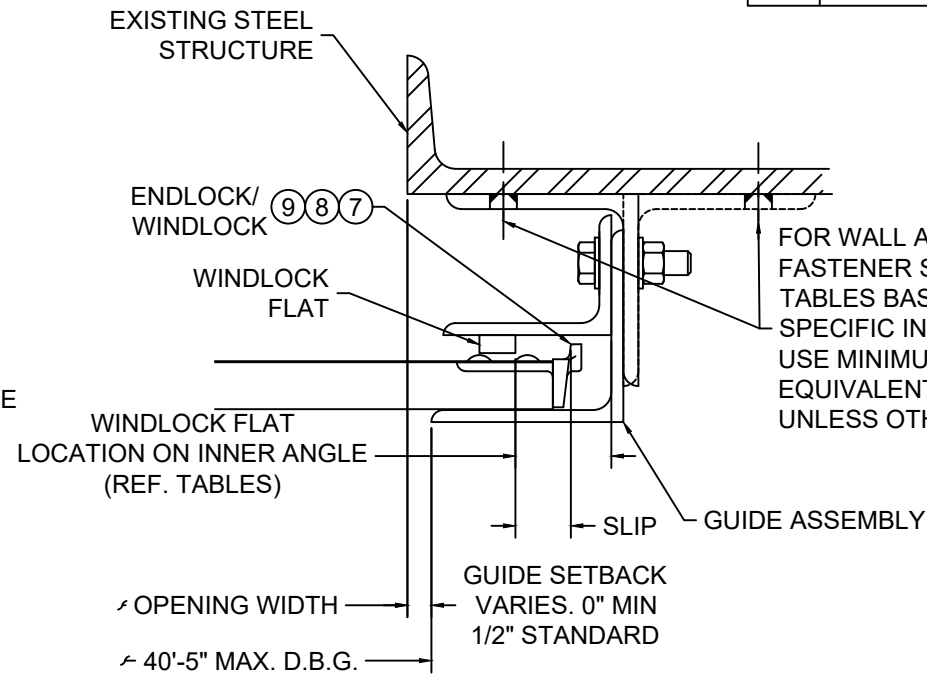

⑥ GUIDE ASSEMBLY  
STEEL STRUCTURE  
(Z-GUIDE OR E-GUIDE)

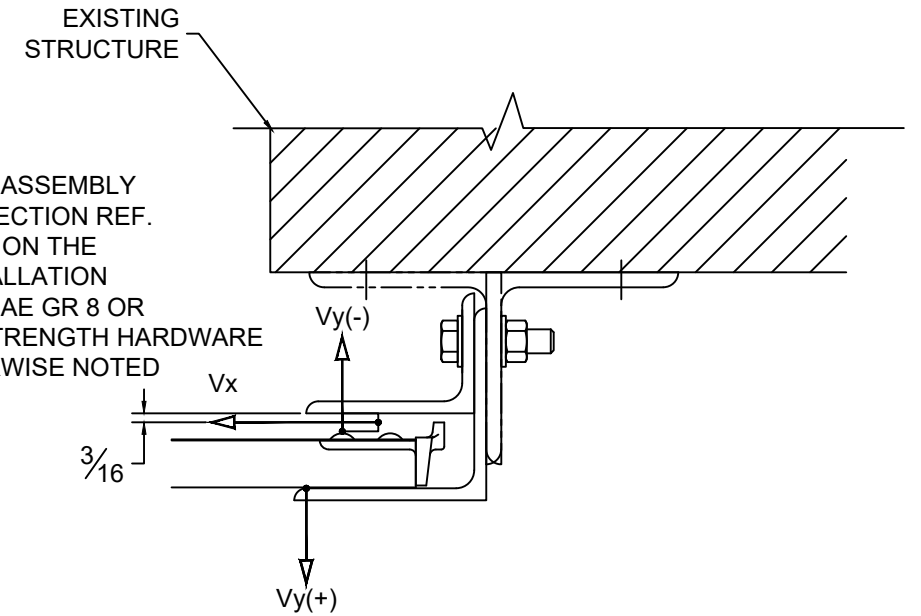

NOTE:

1.  $V_x$  &  $V_y$  ARE HORIZ. AND VERT. COMPONENTS OF THE REACTION, RESPECTIVELY, RESULTING FROM WIND LOADS ON THE ROLL-UP DOOR. THE EXISTING STRUCTURE SHALL BE CAPABLE OF RESISTING  $V_x$  &  $V_y$  FORCES SHOWN AND THE CORRESPONDING REACTIONS DUE TO THE ECCENTRICITIES OF THE FORCES.

⑦ SUPERIMPOSED LOAD DIAGRAM  
SCALE: 3" = 1'-0"

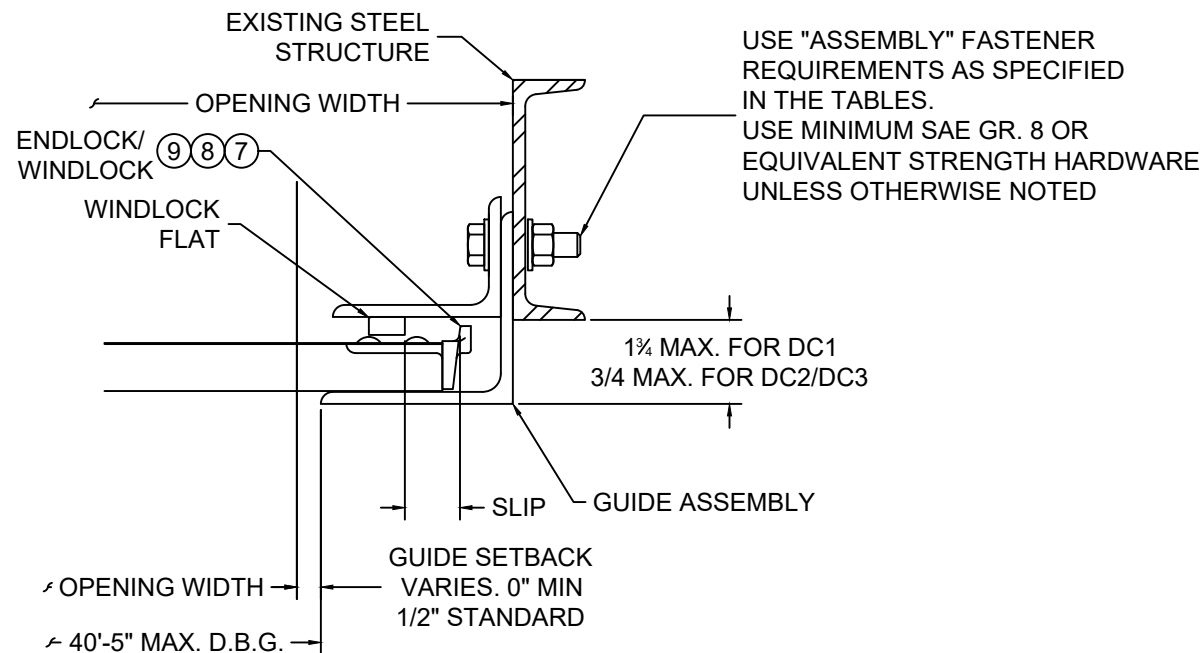

④ GUIDE ASSEMBLY  
STEEL STRUCTURE  
(BETWEEN JAMBS GUIDE)



CLOPAY CORPORATION  
8585 DUKE BOULEVARD  
MASON, OH 45040

P: 800.225.6729  
F: 513.440.4853

Unless otherwise specified,  
dimensions are in inches &  
tolerances are:

0.000 = +/- 0.031  
FRACTIONAL = +/- 1/32  
ANGLES = +/- 1/2 DEG

TITLE: WIND LOAD CONFIGURATION  
INSULATED ROLLING STEEL DOOR  
CP0001/CP0651 SLAT NON-IMPACT RATED

DRAWN BY: TJE  
SIZE: B  
SCALE: AS NOTED  
SHEET: 3/8

DWG NO: ES-16-71-CLO

L'TR	REVISION	DATE	BY	E.C.O.
*	ORIGINAL ISSUE	11/20/14	TJE	1616
A	REVISED AVAILABLE CONFIGURATIONS	04/27/16	TJE	1616
B	REVISED MAXIMUM HEIGHT NOTE	08/10/16	TJE	1616
C	HOOD SUPPORT UPDATE; 2018 IBC	03/09/20	MAN	2028

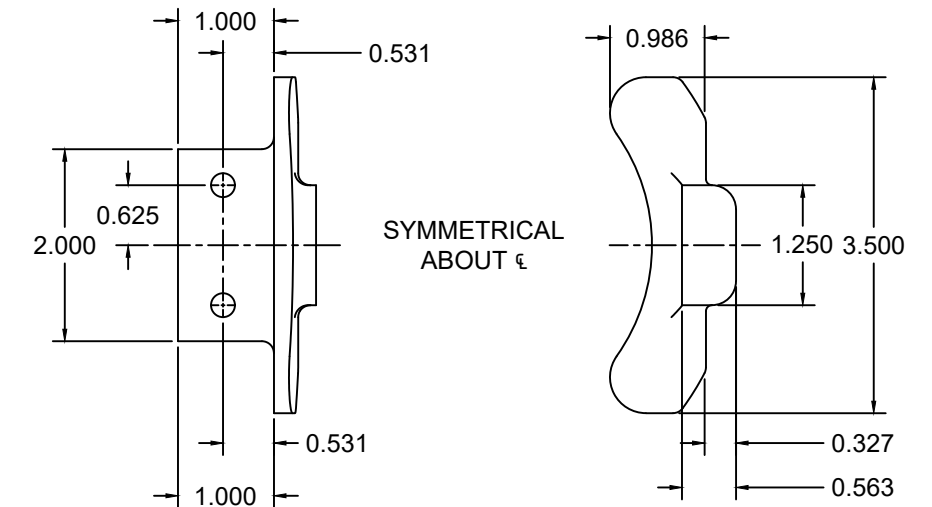
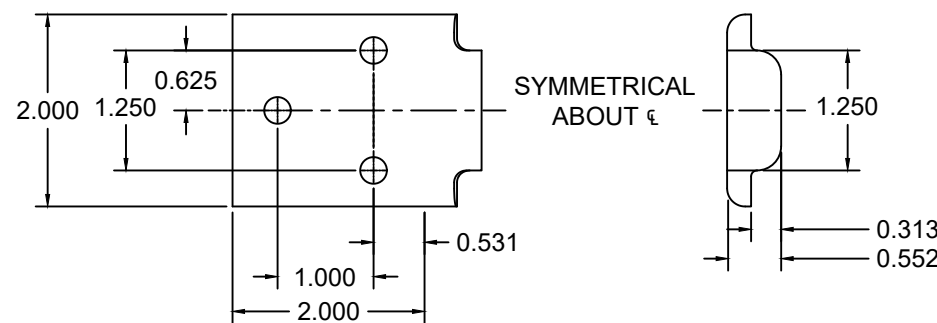
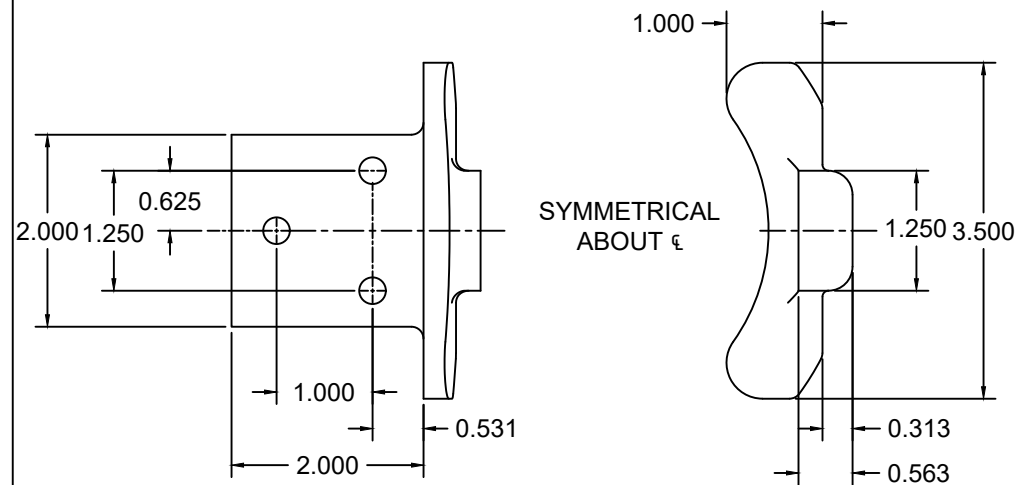
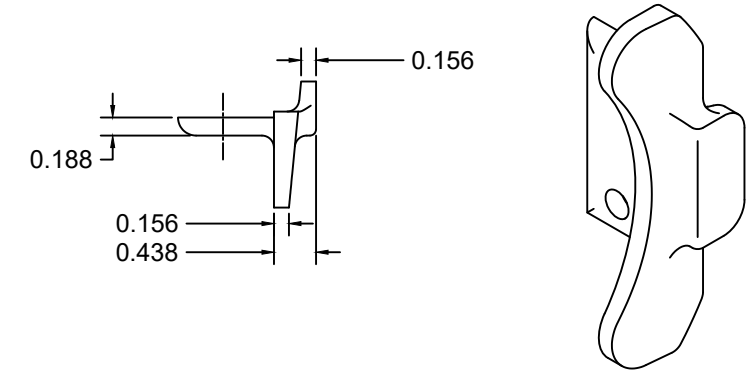
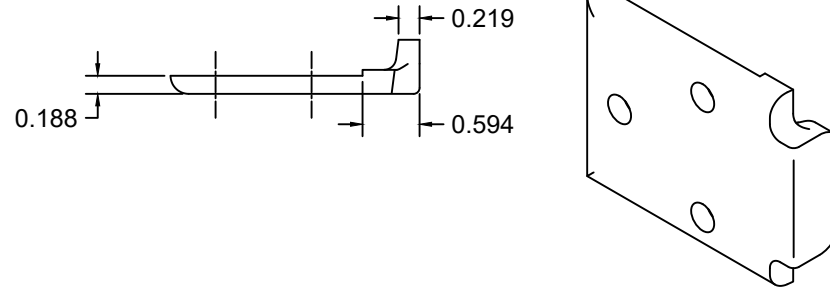
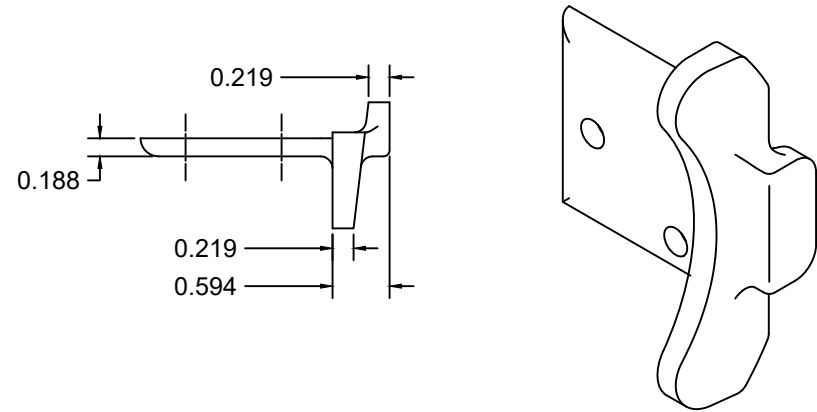

⑦ CP0630 ENDLOCK / WINDLOCK DETAIL  
 CAST MALLEABLE IRON ASTM A47, GRADE 32510, OR  
 DUCTILE IRON PER ASTM A536 GRADE 65-45-12, GALVANIZED IN ACCORDANCE WITH  
 ASTM A123, GRADE 85 ZINC-COATING  
 1/2 SCALE

⑧ CP0647 WINDLOCK DETAIL  
 CAST MALLEABLE IRON ASTM A47, GRADE 32510, OR  
 DUCTILE IRON PER ASTM A536 GRADE 65-45-12, GALVANIZED IN  
 ACCORDANCE WITH ASTM A123, GRADE 85 ZINC-COATING  
 1/2 SCALE

⑨ CP0629 ENDLOCK / WINDLOCK DETAIL  
 CAST MALLEABLE IRON ASTM A47, GRADE 32510, OR  
 DUCTILE IRON PER ASTM A536 GRADE 65-45-12, GALVANIZED IN ACCORDANCE WITH  
 ASTM A123, GRADE 85 ZINC-COATING  
 1/2 SCALE



CLOPAY CORPORATION  
 8585 DUKE BOULEVARD  
 MASON, OH 45040

P: 800.225.6729  
 F: 513.440.4853

Unless otherwise specified,  
 dimensions are in inches &  
 tolerances are:

0.000 = +/- 0.031  
 FRACTIONAL = +/- 1/32  
 ANGLES = +/- 1/2 DEG

TITLE: WIND LOAD CONFIGURATION  
 INSULATED ROLLING STEEL DOOR  
 CP0001/CP0651 SLAT NON-IMPACT RATED

DRAWN BY: TJE  
 SIZE: B  
 SCALE: AS NOTED  
 SHEET: 4/8

DWG NO: ES-16-71-CLO



L'TR	REVISION	DATE	BY	E.C.O.
*	ORIGINAL ISSUE	11/20/14	TJE	1616
A	REVISED AVAILABLE CONFIGURATIONS	04/27/16	TJE	1616
B	REVISED MAXIMUM HEIGHT NOTE	08/10/16	TJE	1616
C	HOOD SUPPORT UPDATE; 2018 IBC	03/09/20	MAN	2028

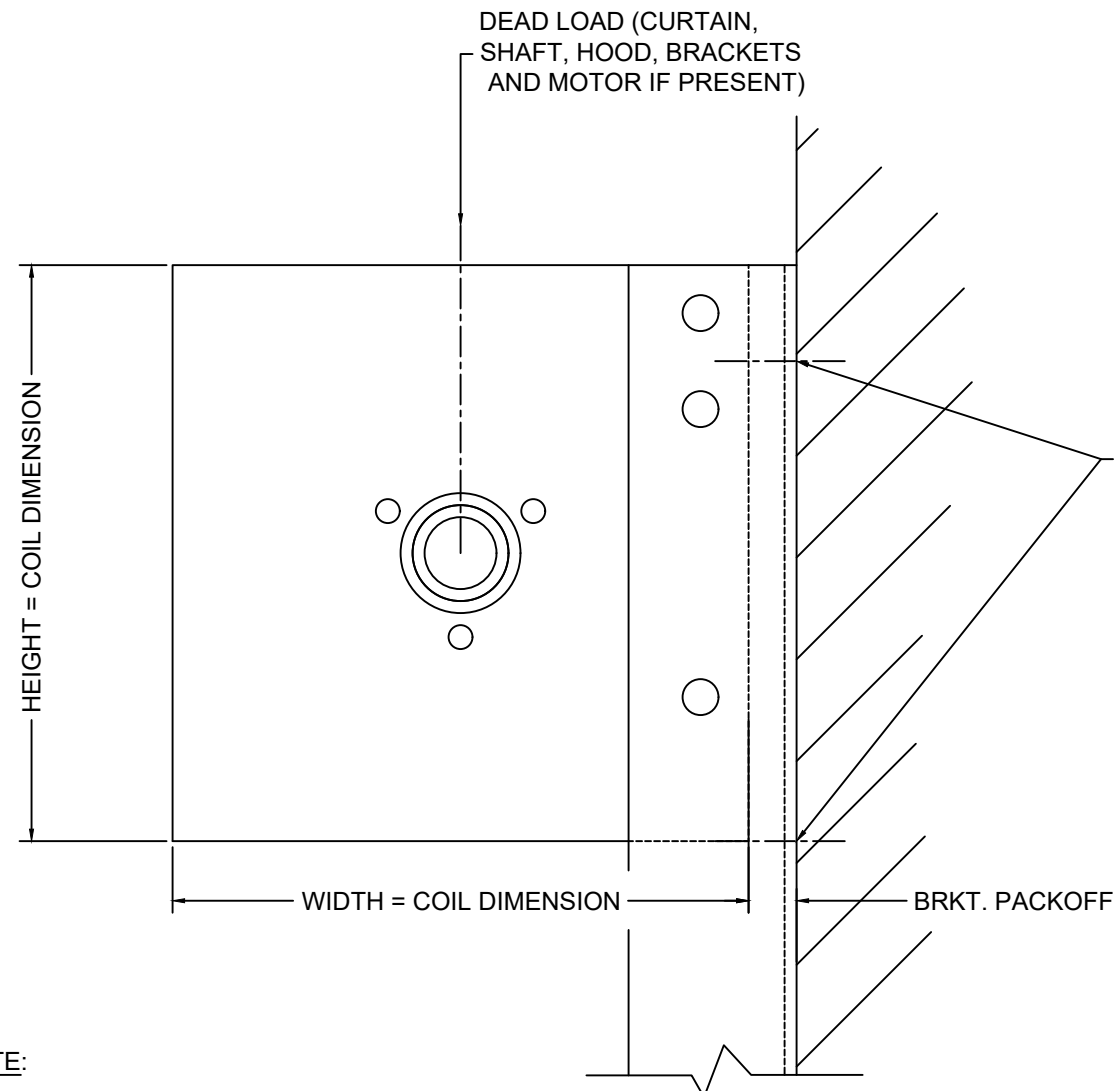

**NOTE:**

1. WHEN MOTOR IS PROVIDED, HEIGHT OR WIDTH DIMENSION MAY INCREASE UP TO 2-1/2" BASED ON MOTOR LOCATION. WHEN AN 8" DIAMETER OR LARGER SHAFT ASSEMBLY IS PROVIDED, HEIGHT DIMENSION INCREASES BY 2".

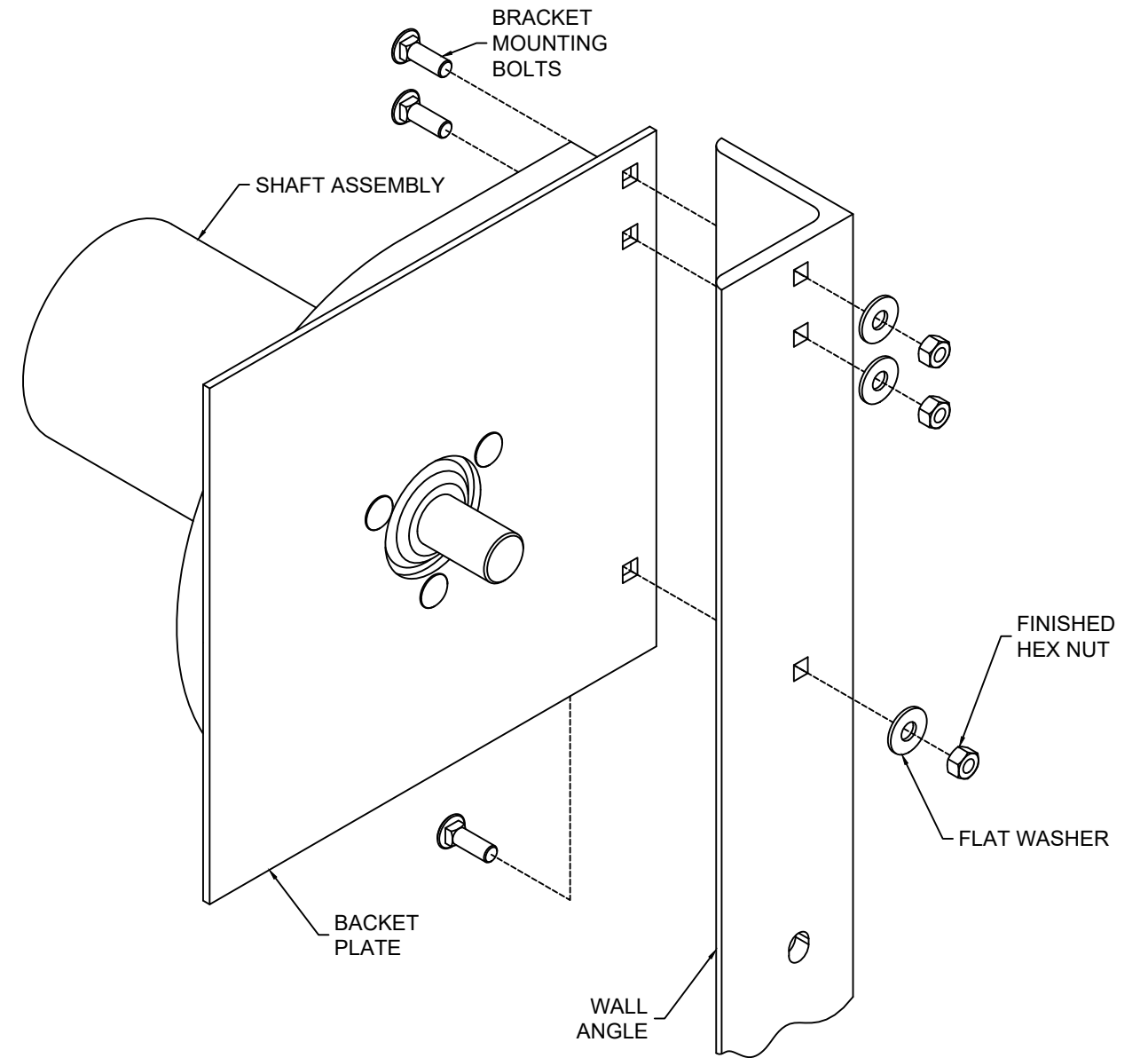

**NOTE:**

1. STANDARD BRACKET MOUNTING DETAIL IS DEPICTED, OTHER MOUNTINGS ARE AVAILABLE



CLOPAY CORPORATION  
8585 DUKE BOULEVARD  
MASON, OH 45040

P: 800.225.6729  
F: 513.440.4853

Unless otherwise specified, dimensions are in inches & tolerances are:

0.000 = +/- 0.031  
FRACTIONAL = +/- 1/32  
ANGLES = +/- 1/2 DEG

TITLE: <b>WIND LOAD CONFIGURATION INSULATED ROLLING STEEL DOOR CP0001/CP0651 SLAT NON-IMPACT RATED</b>	DRAWN BY: <b>TJE</b>	SIZE: <b>B</b>	SCALE: <b>AS NOTED</b>	SHEET: <b>5/8</b>
	DWG NO: <b>ES-16-71-CLO</b>			

L'TR	REVISION	DATE	BY	E.C.O.
*	ORIGINAL ISSUE	11/20/14	TJE	1616
A	REVISED AVAILABLE CONFIGURATIONS	04/27/16	TJE	1616
B	REVISED MAXIMUM HEIGHT NOTE	08/10/16	TJE	1616
C	HOOD SUPPORT UPDATE; 2018 IBC	03/09/20	MAN	2028

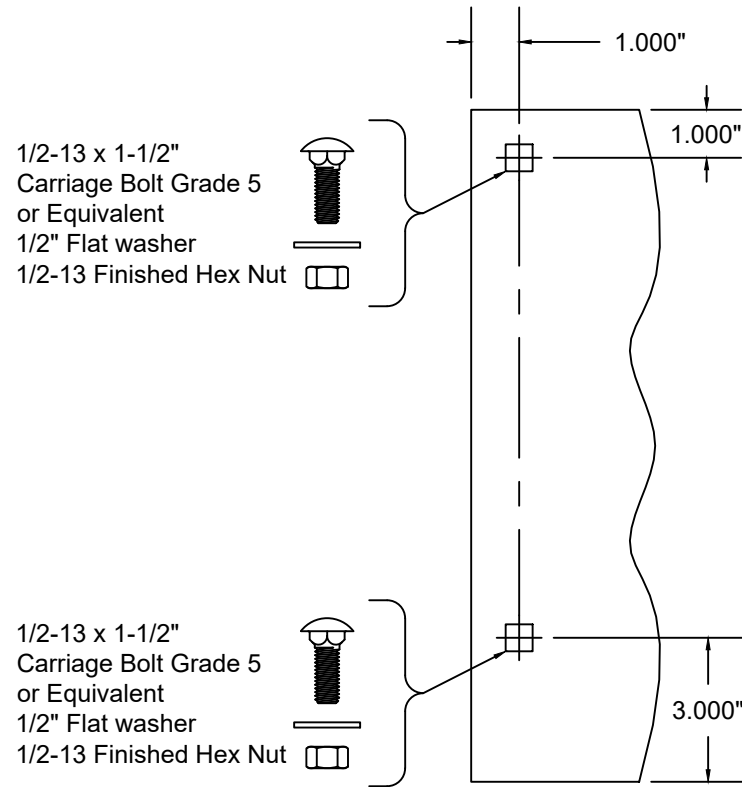

**THRU 6"Ø SHAFT ASSEMBLY**  
**14" THRU 16" COIL DIMENSION**  
**MIN. THICKNESS 0.172" ASTM A36**  
**OR ASTM A480 STAINLESS STEEL,**  
**TYPES 304 OR 316, MINIMUM 36 KSI YIELD STRENGTH**  
 SCALE: 1-1/2" = 1'-0"

1/2-13 x 1-1/2"  
 Carriage Bolt Grade 5  
 or Equivalent  
 1/2" Flat washer  
 1/2-13 Finished Hex Nut

1/2-13 x 1-1/2"  
 Carriage Bolt Grade 5  
 or Equivalent  
 1/2" Flat washer  
 1/2-13 Finished Hex Nut

1/2-13 x 1-1/2"  
 Carriage Bolt Grade 5  
 or Equivalent  
 1/2" Flat washer  
 1/2-13 Finished Hex Nut

NOTE:  
 WHEN A 8"Ø OR LARGER SHAFT  
 ASSEMBLY IS PROVIDED, THERE IS  
 A 2" EXTENSION ON THE BOTTOM  
 OF THE BRACKET.

**THRU 10"Ø SHAFT ASSEMBLY**  
**17" AND LARGER COIL DIMENSION**  
**MIN. THICKNESS 0.240" ASTM A36**  
**OR ASTM A480 STAINLESS STEEL,**  
**TYPES 304 OR 316, MINIMUM 36 KSI YIELD STRENGTH**  
 SCALE: 1-1/2" = 1'-0"

1/2-13 x 1-1/2"  
 Carriage Bolt Grade 5  
 or Equivalent  
 1/2" Flat washer  
 1/2-13 Finished Hex Nut

1/2-13 x 1-1/2"  
 Carriage Bolt Grade 5  
 or Equivalent  
 1/2" Flat washer  
 1/2-13 Finished Hex Nut

1/2-13 x 1-1/2"  
 Carriage Bolt Grade 5  
 or Equivalent  
 1/2" Flat washer  
 1/2-13 Finished Hex Nut

1/2-13 x 1-1/2"  
 Carriage Bolt Grade 5  
 or Equivalent  
 1/2" Flat washer  
 1/2-13 Finished Hex Nut

**12"Ø SHAFT ASSEMBLY**  
**17" AND LARGER COIL DIMENSION**  
**MIN. THICKNESS 0.240" ASTM A36**  
**OR ASTM A480 STAINLESS STEEL,**  
**TYPES 304 OR 316, MINIMUM 36 KSI YIELD STRENGTH**  
 SCALE: 1-1/2" = 1'-0"



CLOPAY CORPORATION  
 8585 DUKE BOULEVARD  
 MASON, OH 45040

P: 800.225.6729  
 F: 513.440.4853

Unless otherwise specified,  
 dimensions are in inches &  
 tolerances are:

0.000 = +/- 0.031  
 FRACTIONAL = +/- 1/32  
 ANGLES = +/- 1/2 DEG

TITLE: **WIND LOAD CONFIGURATION**  
**INSULATED ROLLING STEEL DOOR**  
**CP0001/CP0651 SLAT NON-IMPACT RATED**

DRAWN BY: **TJE** SIZE: **B** SCALE: **AS NOTED** SHEET: **6/8**

DWG NO: **ES-16-71-CLO**

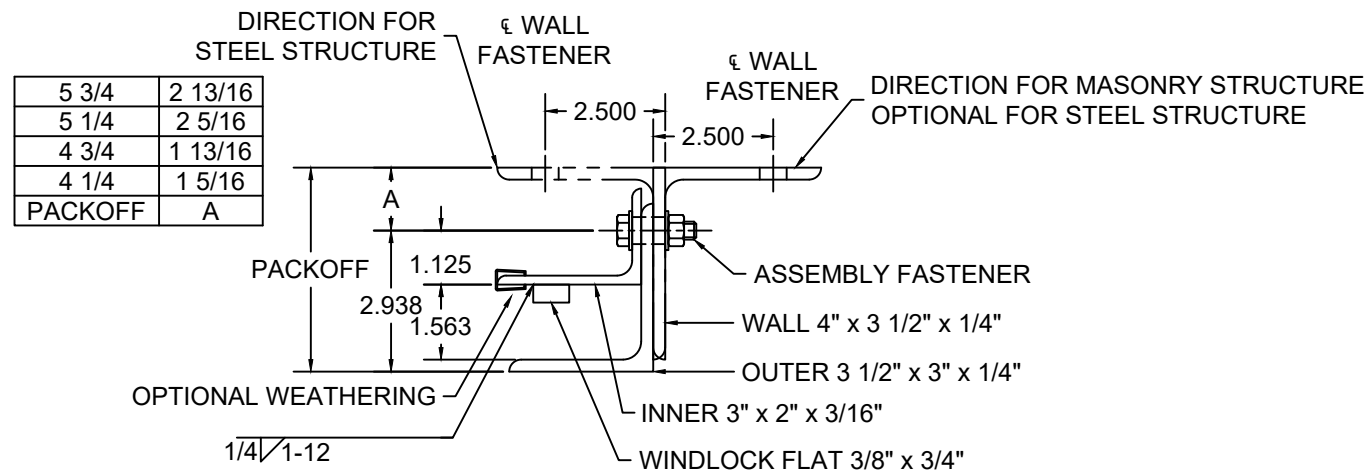

GUIDE ASSEMBLY TYPE DC1  
SCALE: 3" = 1'-0"

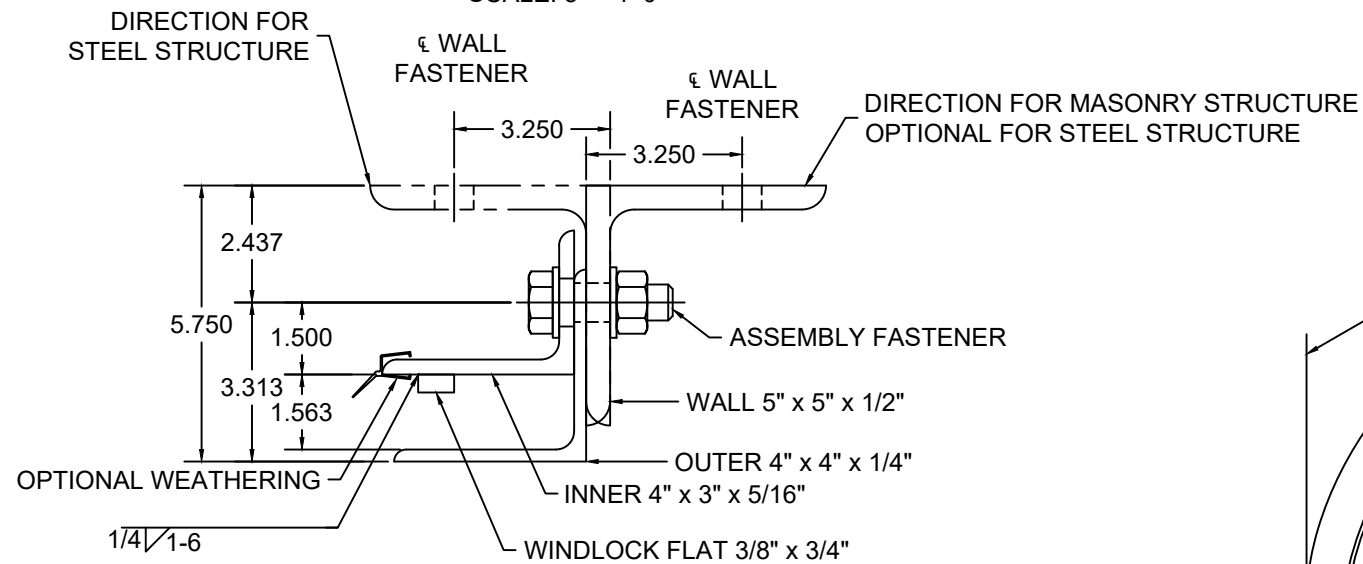

GUIDE ASSEMBLY TYPE DC2  
SCALE: 3" = 1'-0"

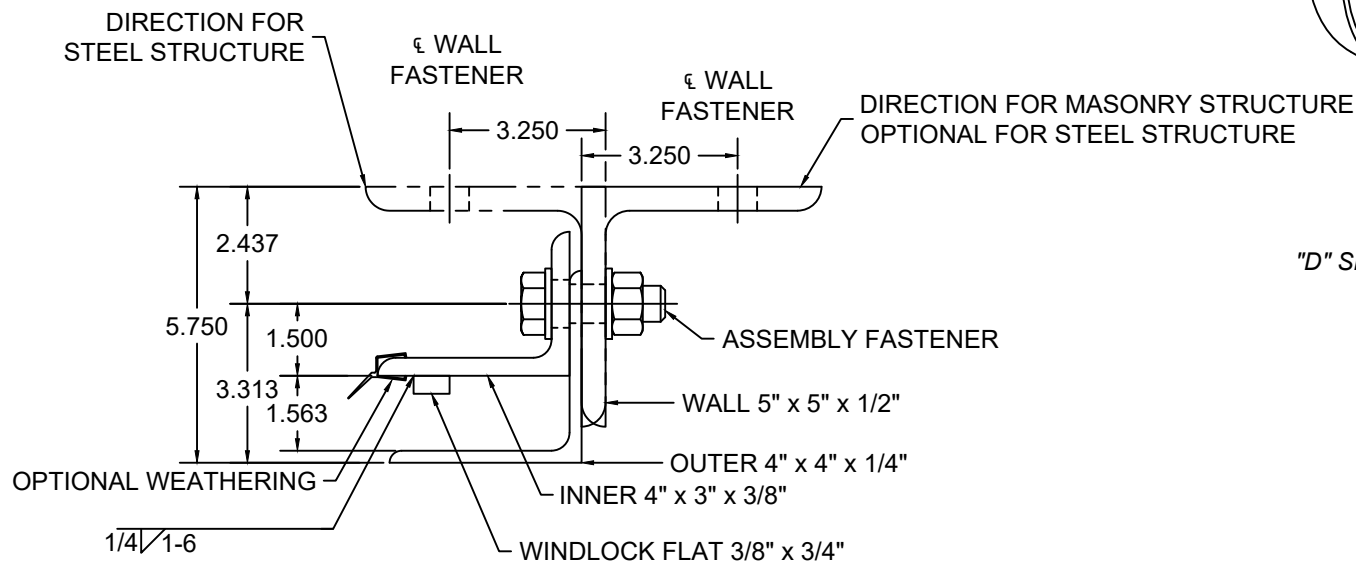

GUIDE ASSEMBLY TYPE DC3  
SCALE: 3" = 1'-0"

L'TR	REVISION	DATE	BY	E.C.O.
*	ORIGINAL ISSUE	11/20/14	TJE	1616
A	REVISED AVAILABLE CONFIGURATIONS	04/27/16	TJE	1616
B	REVISED MAXIMUM HEIGHT NOTE	08/10/16	TJE	1616
C	HOOD SUPPORT UPDATE; 2018 IBC	03/09/20	MAN	2028

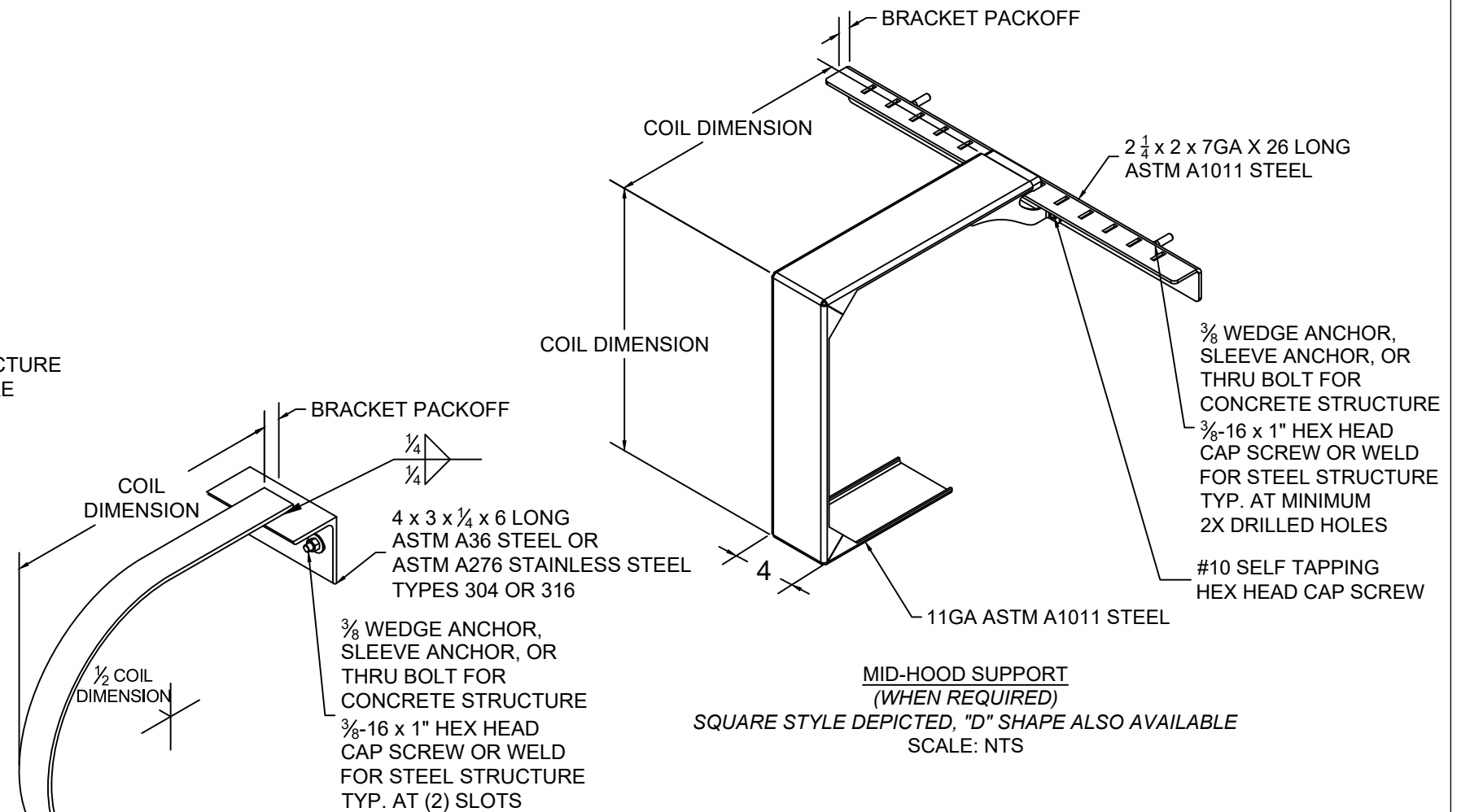

MID-HOOD SUPPORT  
(WHEN REQUIRED)  
SCALE: NTS

"D" SHAPE DEPICTED, SQUARE STYLE ALSO AVAILABLE



CLOPAY CORPORATION  
8585 DUKE BOULEVARD  
MASON, OH 45040

P: 800.225.6729  
F: 513.440.4853

Unless otherwise specified,  
dimensions are in inches &  
tolerances are:

0.000 = +/- 0.031  
FRACTIONAL = +/- 1/32  
ANGLES = +/- 1/2 DEG

TITLE: WIND LOAD CONFIGURATION  
INSULATED ROLLING STEEL DOOR  
CP0001/CP0651 SLAT NON-IMPACT RATED

DRAWN BY: TJE  
SIZE: B  
SCALE: AS NOTED  
SHEET: 7/8

DWG NO: ES-16-71-CLO

L'TR	REVISION	DATE	BY	E.C.O.
*	ORIGINAL ISSUE	11/20/14	TJE	1616
A	REVISED AVAILABLE CONFIGURATIONS	04/27/16	TJE	1616
B	REVISED MAXIMUM HEIGHT NOTE	08/10/16	TJE	1616
C	HOOD SUPPORT UPDATE; 2018 IBC	03/09/20	MAN	2028

**CP0001/CP0651 -Galvanized or Stainless Steel**

Door Configuration	Minimum Front Slat Thickness	Maximum Pressure	Windlock Flat Location	Slip	Windlock	Guide Assembly	Windlock Weld Pitch	Assembly Fastener Diameter	Assembly Fastener Spacing	Concrete Minimum 3,000 PSI Compressive Strength (Anchors are the same diameter as assembly fasteners)							
										Hilti Kwik Bolt 3				Simpson Wedge All			
										Max O.C.	Embed	Min. Wall Thick.	Edge Dist	Max O.C.	Embed	Min. Wall Thick.	Edge Dist
DC 1	0.0296	65 PSF	1 5/16	0.532	CP0629	DC1	12	1/2	18	16	3 1/2	5 1/4	5 3/4	16	4 1/2	6 3/4	5 3/4
DC 2	0.0405	120 PSF	1 1/2	0.656	CP0630 & CP0647	DC2	6	3/4	15	11	4 3/4	7 1/8	7 1/2	11	5	7 1/2	7 1/2
DC 3	0.0405	65 PSF	2 1/2	1.656	CP0630 & CP0647	DC3	6	3/4	15	11	4 3/4	7 1/8	7 1/2	11	5	7 1/2	7 1/2

**CP0001/CP0651 - Galvanized or Stainless Steel, Cont.**

Door Configuration	Filled CMU								Steel (Wall anchors are the same diameter as assembly fasteners)							Superimposed Loads (at Maximum Pressure)				
	Hilti Kwik Bolt 3				Simpson Wedge-All				Through Bolt			Welded		Through Bolt	Tapped		Vx (+)	Vy (+)	Vx (-)	Vy (-)
	Max O.C.	Dia.	Embed	Edge Dist	Max O.C.	Dia.	Embed	Edge Dist	Max. O.C.	Dia.	Edge Dist	Max O.C.	Slot Size	Max O.C.	Max O.C.	Min. Thickness				
DC 1	8	1/2	3 1/2	5 3/4	8	1/2	4 1/2	5 3/4	N/A			18	9/16 X 3/4	18	18	1/4	566	406	517	404
DC 2	N/A				N/A				8	3/4	7 1/2	15	13/16 x 1	15	15	3/8	2956	871	2881	871
DC 3	N/A				N/A				8	3/4	7 1/2	15	13/16 x 1	15	15	3/8	2861	825	2844	826

SEE CHARTS BELOW FOR MAXIMUM PRESSURE/WIDTH COMBINATIONS FOR EACH DOOR CONFIGURATION

DC 1 Door Configuration	
DBG Up To	Maximum Pressure
12'-5"	65 PSF (Tested)
13'-5"	50 PSF
14'-5"	40 PSF
15'-5"	30 PSF
18'-5"	20 PSF

DC 2 Door Configuration	
DBG Up To	Maximum Pressure
14'-5"	120 PSF (Tested)
15'-5"	100 PSF
16'-5"	90 PSF
17'-5"	80 PSF
18'-5"	70 PSF
20'-5"	60 PSF
22'-5"	50 PSF
25'-5"	40 PSF
30'-5"	30 PSF
39'-5"	20 PSF

DC 3 Door Configuration	
DBG Up To	Maximum Pressure
25'-5"	65 PSF (Tested)
26'-5"	60 PSF
29'-5"	50 PSF
33'-5"	40 PSF
40'-5"	30 PSF



CLOPAY CORPORATION  
8585 DUKE BOULEVARD  
MASON, OH 45040

P: 800.225.6729  
F: 513.440.4853

Unless otherwise specified, dimensions are in inches & tolerances are:

0.000 = +/- 0.031  
FRACTIONAL = +/- 1/32  
ANGLES = +/- 1/2 DEG

TITLE: <b>WIND LOAD CONFIGURATION INSULATED ROLLING STEEL DOOR CP0001/CP0651 SLAT NON-IMPACT RATED</b>	DRAWN BY: <b>TJE</b>	SIZE: <b>B</b>	SCALE: <b>AS NOTED</b>	SHEET: <b>8/8</b>
	DWG NO: <b>ES-16-71-CLO</b>			