

LARGE MISSILE IMPACT RESISTANCE

THE METHOD OF TESTING WAS IN SUBSTANTIAL CONFORMANCE WITH THE PROCEDURE DESCRIBED IN ASTM E330 AND DASMA 108. THE PRESSURES SHOWN ON THE DRAWINGS WERE CALCULATED USING ASCE 7-98/02/05 WITH THE FOLLOWING PARAMETERS (5 FEET OF DOOR WIDTH IN THE END ZONE, ROOF AT ANY SLOPE, AND I=1.0):

WIND SPEED (MPH)	139	126	120	114	110
EXPOSURE LEVEL	B	C	C	D	D
MEAN ROOF HEIGHT	30'	15'	25'	15'	25'

REV	DESCRIPTION OF REVISIONS	DATE	BY
A	REVISED NOTE 6	9/3/08	BHG
B	WIND SPEED TABLE & TRACK CONFIGURATIONS	04/20/12	RLR

MAX SIZE
16' WIDTH
14' HEIGHT
(DOOR HEIGHT SUBJECT TO WEIGHT LIMITATIONS)
DESIGN LOADS
+29.7 PSF
-33.1 PSF
TEST LOADS
+44.6 PSF
-49.7 PSF
LARGE MISSILE IMPACT RESISTANCE

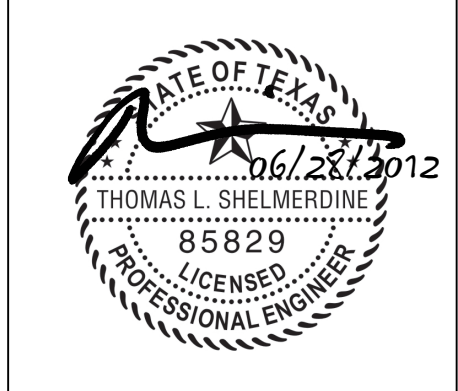

Amarr

165 CARRIAGE COURT WINSTON-SALEM, N.C. 27105 WWW.AMARR.COM

MODEL #600 STRATFORD 1000, 2000
MODEL #650 OAK SUMMIT 1000, 2000
MODEL #950 HERITAGE 1000, 2000
Short, Long, Flush & Oak Summit Panel's

SIZE	DRAWN BY	BHG	DATE	3/06/07	DRAWING NUMBER
B	CHECKED BY	BHG	DATE	3/06/07	IRC-6016-140-24-1

ENGINEER: THOMAS L. SHELMEARDINE P.E. LIC. No. 0048579 SHEET 1 OF 3

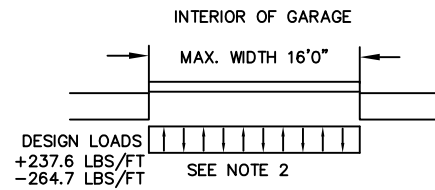

SPECIFICATIONS AND NOTES

1. ALL THE LOAD FROM THE DOOR IS TRANSFERRED TO THE VERTICAL TRACK, FROM THE TRACK THE TRACK LOAD IS TRANSFERRED TO THE VERTICAL JAMBS. THE HORIZONTAL JAMB OR HEADER RECEIVES NO PORTION OF THE LOAD.
2. EACH VERTICAL JAMB RECEIVES MAXIMUM DESIGN LOADS OF +237.6 LBS/FT & -264.7 LBS/FT.
3. DOORS AND HARDWARE WILL BE DESIGNED, MANUFACTURED, AND INSTALLED WITH STANDARDS AS SET FORTH BY DASMA
4. DOOR SECTIONS SHALL BE 25GA. MIN (.019 MIN) ROLLED FORMED LIGHT COMMERCIAL QUALITY
5. SUPPORTING STRUCTURAL ELEMENTS SHALL BE DESIGNED BY A REGISTERED PROFESSIONAL ENGINEER FOR WIND LOADS INDICATED ON THIS DRAWING IN ADDITION TO OTHER LOADINGS
6. REFER TO TABLES ON PAGE 3 FOR ADDITIONAL DOOR WIDTHS AND HEIGHTS

TABLE 1

DOOR HEIGHT	STRUT SPACING (BASED ON RECOMMENDED SECTION CONFIGURATION)								TOP
	A	B	C	D	E	F	G	H	
6' 6"	5 1/2"	16"	34"	52"					70 1/2"
7'	5 1/2"	16"	37"	58"					76 1/2"
7' 6"	5 1/2"	13"	31"	49"	67"				82 1/2"
8'	5 1/2"	16"	34"	52"	70"				88 1/2"
8' 6"	5 1/2"	16"	37"	58"	76"				94 1/2"
9'	5 1/2"	13"	31"	49"	67"	85"			100 1/2"
9' 6"	5 1/2"	16"	34"	52"	70"	88"			106 1/2"
10'	5 1/2"	16"	37"	58"	76"	94"			112 1/2"
10' 6"	5 1/2"	16"	37"	58"	79"	100"			118 1/2"
11'	5 1/2"	16"	34"	52"	70"	88"	106"		124 1/2"
11' 6"	5 1/2"	16"	37"	58"	76"	94"	112"		130 1/2"
12'	5 1/2"	16"	37"	58"	79"	100"	118"		136 1/2"
12' 6"	5 1/2"	16"	34"	52"	70"	88"	106"	124"	142 1/2"
13'	5 1/2"	16"	37"	58"	76"	94"	112"	130"	148 1/2"
13' 6"	5 1/2"	16"	37"	58"	79"	100"	118"	136"	154 1/2"
14'	5 1/2"	16"	37"	58"	79"	100"	121"	142"	160 1/2"

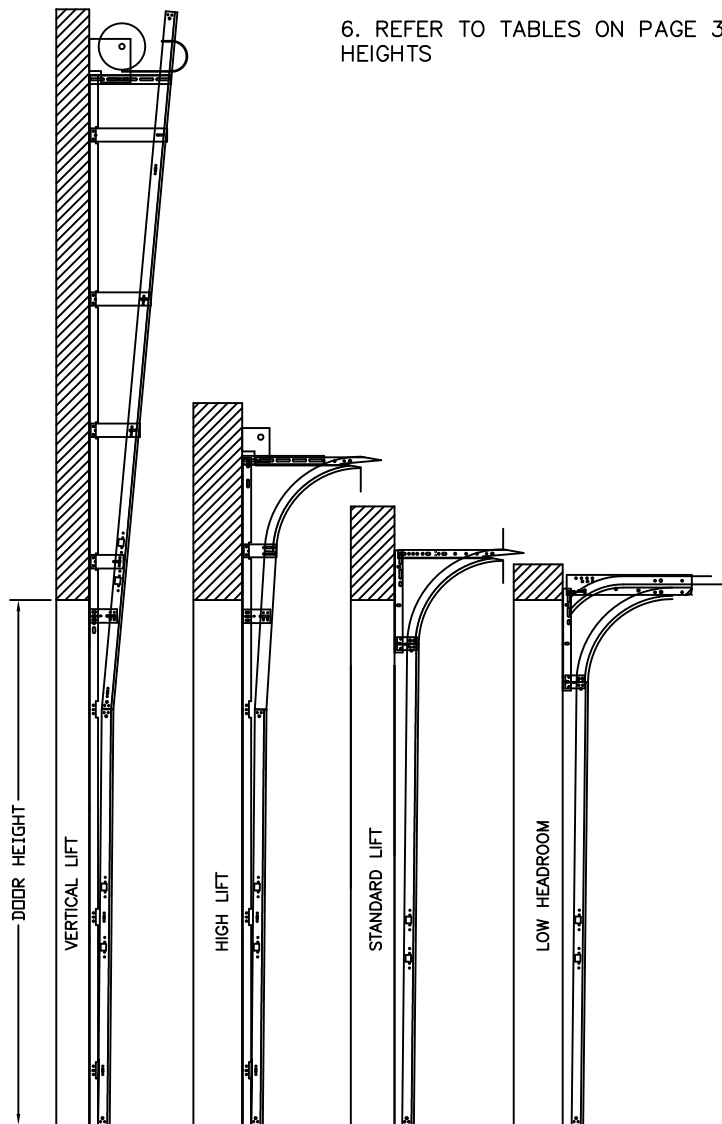

AVAILABLE TRACK CONFIGURATIONS
N.T.S.

WOOD JAMB ATTACHMENT TO STRUCTURE

2 X 6 VERTICAL JAMB ATTACHMENT TO WOOD FRAME STRUCTURE
 5/16" X 3" LAG SCREWS STARTING 6" FROM ENDS THEN 20" O.C. (1 1/2" EMBEDMENT)
2 X 6 VERTICAL JAMB ATTACHMENT TO 2,000 PSI CONCRETE
 HILTI KWIK BOLT 3/8" X 4" STARTING 6" FROM ENDS THEN 24" O.C. (2 1/2" EMBEDMENT)
 HILTI SLEEVE ANCHOR 3/8" X 2-3/4" STARTING 6" FROM ENDS THEN 18" O.C. (1 1/4" EMBEDMENT)
 ITW/RAMSET REDHEAD (TRU-BOLT) 3/8" X 4" STARTING 6" FROM ENDS THEN 24" O.C. (2 1/2" EMBEDMENT)
2 X 6 VERTICAL JAMB ATTACHMENT TO HOLLOW C-90 BLOCK
 SIMPSON 1/4" X 3" TITEN SCREWS STARTING 6" FROM ENDS, USE PAIRS OF FASTENERS (3" APART) AT 8" O.C. (1 1/2" EMBEDMENT)
 HILTI 1/4" X 2-3/4" KWIK-CON II+ SCREWS STARTING 6" FROM ENDS, USE PAIRS OF FASTENERS (3" APART) AT 14" O.C. (1 1/4" EMBEDMENT)

2 X 6 VERTICAL JAMB ATTACHMENT TO GROUTED C-90 BLOCK (2000 PSI GROUT)
 HILTI SLEEVE ANCHOR 3/8" X 2-3/4" STARTING 6" FROM ENDS THEN 20" O.C. (1 1/4" EMBEDMENT) (OR, USE FASTENERS FOR HOLLOW C-90 BLOCK)

*LAGS AND BOLTS CAN BE COUNTERSUNK TO PROVIDE A FLUSH MOUNTING SURFACE.
 *PREPARATION OF WOOD JAMBS BY OTHERS

REV	DESCRIPTION OF REVISIONS	DATE	BY
A	REVISED NOTE 6	9/3/08	BHG
B	WIND SPEED TABLE & TRACK CONFIGURATIONS	04/20/12	RLR

MAX SIZE
16' WIDTH
14' HEIGHT
(DOOR HEIGHT SUBJECT TO WEIGHT LIMITATIONS)
DESIGN LOADS
+29.7 PSF
-33.1 PSF
TEST LOADS
+44.6 PSF
-49.7 PSF
LARGE MISSILE IMPACT RESISTANCE

Amarr
 165 CARRIAGE COURT WINSTON-SALEM, N.C. 27105 WWW.AMARR.COM
MODEL #600 STRATFORD 1000, 2000
MODEL #650 OAK SUMMIT 1000, 2000
MODEL #950 HERITAGE 1000, 2000
Short, Long, Flush & Oak Summit Panel's

SIZE	DRAWN BY	BHG	DATE	3/06/07	DRAWING NUMBER
B	CHECKED BY	BHG	DATE	3/06/07	IRC-6016-140-24-1

ENGINEER: THOMAS L. SHELMERDINE P.E. LIC. No. 0048579 SHEET 2 OF 3

TABLE 2

DOOR HEIGHT	SECTION HEIGHTS							
	Btm	#2	#3	#4	#5	#6	#7	#8
14' 0"	21"	21"	21"	21"	21"	21"	21"	21"
13' 6"	21"	21"	21"	21"	21"	18"	18"	21"
13' 0"	21"	21"	21"	18"	18"	18"	18"	21"
12' 6"	21"	18"	18"	18"	18"	18"	18"	21"
12' 0"	21"	21"	21"	21"	21"	18"	21"	
11' 6"	21"	21"	21"	18"	18"	18"	21"	
11' 0"	21"	18"	18"	18"	18"	18"	21"	
10' 6"	21"	21"	21"	21"	21"	21"		
10' 0"	21"	21"	21"	18"	18"	21"		
9' 6"	21"	18"	18"	18"	18"	21"		
9' 0"	18"	18"	18"	18"	18"	18"		
8' 6"	21"	21"	21"	18"	21"			
8' 0"	21"	18"	18"	18"	21"			
7' 6"	18"	18"	18"	18"	18"			
7' 0"	21"	21"	21"	21"				
6' 6"	21"	18"	18"	21"				

TABLE 3

DOOR HEIGHT	TRACK ATTACHMENT								SPLICE S
	A	B	C	D	E	F	G	H	
6' 6"	10"	21"	39"	57"					70"
7'	10"	21"	42"	63"					76"
7' 6"	10"	18"	36"	54"	72"				82"
8'	10"	21"	39"	57"	75"				88"
8' 6"	10"	21"	42"	63"	81"				94"
9'	10"	18"	36"	54"	72"	90"			100"
9' 6"	10"	21"	39"	57"	75"	93"			106"
10'	10"	21"	42"	63"	81"	99"			112"
10' 6"	10"	21"	42"	63"	84"	105"			118"
11'	10"	21"	39"	57"	75"	93"	111"		124"
11' 6"	10"	21"	42"	63"	81"	99"	117"		130"
12'	10"	21"	42"	63"	84"	105"	123"		136"
12' 6"	10"	21"	39"	57"	75"	93"	111"	129"	142"
13'	10"	21"	42"	63"	81"	99"	117"	135"	148"
13' 6"	10"	21"	42"	63"	84"	105"	123"	141"	154"
14'	10"	21"	42"	63"	84"	105"	126"	147"	160"

ALL TRACK ATTACHMENT SPACING +/-2" WITH SYP NO. 2 OR BETTER ONLY

TABLE 4

Section Width (ft)	Panel Type	Center Stile Locations (Measured from Left Edge)				
		1st (in)	2nd (in)	3rd (in)	4th (in)	5th (in)
10' 0"	Short	48.41	71.59			
10' 0"	Long	30.00	60.00	90.00		
10' 0"	Oak Summit	30.63	60.00	89.38		
12' 0"	Short	48.81	72.00	95.19		
12' 0"	Long	49.63	72.00	94.38		
12' 0"	Oak Summit	48.31	72.00	95.69		
12' 2"	Short	49.64	73.00	96.36		
12' 2"	Long	50.08	73.00	95.92		
12' 2"	Oak Summit	49.06	73.00	96.94		
12' 4"	Short	50.64	74.00	97.36		
12' 4"	Long	51.08	74.00	96.92		
12' 4"	Oak Summit	49.81	74.00	98.19		
12' 6"	Short	50.67	75.00	99.33		
12' 6"	Long	51.17	75.00	98.83		
12' 6"	Oak Summit	50.56	75.00	99.44		
12' 8"	Short	51.67	76.00	100.33		
12' 8"	Long	52.10	76.00	99.90		
12' 8"	Oak Summit	51.31	76.00	100.69		
12' 10"	Short	52.25	77.00	101.75		
12' 10"	Long	53.10	77.00	100.90		
12' 10"	Oak Summit	52.06	77.00	101.94		
13' 0"	Short	53.00	78.00	103.00		
13' 0"	Long	54.10	78.00	101.90		
13' 0"	Oak Summit	52.81	78.00	103.19		
13' 2"	Short	54.00	79.00	104.00		
13' 2"	Long	55.10	79.00	102.90		
13' 2"	Oak Summit	53.56	79.00	104.44		
13' 4"	Short	54.40	80.00	105.60		
13' 4"	Long	54.90	80.00	105.10		
13' 4"	Oak Summit	54.31	80.00	105.69		
13' 6"	Short	55.40	81.00	106.60		
13' 6"	Long	55.90	81.00	106.10		
13' 6"	Oak Summit	55.06	81.00	106.94		
13' 8"	Short	56.40	82.00	107.60		
13' 8"	Long	56.63	82.00	107.38		
13' 8"	Oak Summit	55.81	82.00	108.19		
13' 10"	Short	57.16	83.00	108.71		
13' 10"	Long	57.17	83.00	108.83		
13' 10"	Oak Summit	56.56	83.00	109.44		
14' 0"	Short	57.76	84.00	110.11		
14' 0"	Long	58.63	84.00	109.38		
14' 0"	Oak Summit	57.31	84.00	110.69		
14' 2"	Short	58.85	85.00	111.41		
14' 2"	Long	59.17	85.00	110.83		
14' 2"	Oak Summit	58.06	85.00	111.94		
14' 4"	Short	59.16	86.00	112.71		
14' 4"	Long	60.17	86.00	111.83		
14' 4"	Oak Summit	58.81	86.00	113.19		
14' 6"	Short	59.86	87.00	114.01		
14' 6"	Long	61.17	87.00	112.83		
14' 6"	Oak Summit	59.56	87.00	114.44		
14' 8"	Short	60.56	88.00	115.31		
14' 8"	Long	64.81	86.41	88.00	109.59	131.19
14' 8"	Oak Summit	60.31	88.00	115.69		
14' 10"	Short	61.26	89.00	116.61		
14' 10"	Long	65.60	87.30	89.00	110.70	132.40
14' 10"	Oak Summit	61.06	89.00	116.94		
15' 0"	Short	61.94	89.97	90.00	103.97	117.94
15' 0"	Long	66.60	88.30	90.00	111.70	133.40
15' 0"	Oak Summit	63.63	88.11	90.00	111.81	146.38
15' 2"	Short	62.66	87.83	91.00	105.11	119.21
15' 2"	Long	67.60	89.30	91.00	112.70	134.40
15' 2"	Oak Summit	64.13	87.56	91.00	111.94	147.88
15' 4"	Short	63.60	79.20	104.80	130.40	
15' 4"	Long	67.25	89.63	92.00	114.38	136.75
15' 4"	Oak Summit	64.63	89.31	92.00	112.69	149.38
15' 6"	Short	66.62	89.81	93.00	116.19	139.38
15' 6"	Long	67.60	87.30	93.00	115.70	138.40
15' 6"	Oak Summit	67.42	87.21	93.00	115.79	138.58
15' 8"	Short	67.62	87.81	94.00	117.19	140.38
15' 8"	Long	68.60	87.30	94.00	116.70	139.40
15' 8"	Oak Summit	68.02	87.01	94.00	116.99	139.98
15' 10"	Short	68.62	87.81	95.00	118.19	141.38
15' 10"	Long	69.17	87.08	95.00	117.92	140.83
15' 10"	Oak Summit	68.62	87.81	95.00	118.19	141.38
16' 0"	Short	69.62	87.81	96.00	119.19	142.38
16' 0"	Long	70.60	87.30	96.00	118.70	141.40
16' 0"	Oak Summit	69.42	87.21	96.00	118.79	143.58

^ Stiles do not need to be hinged

REV	DESCRIPTION OF REVISIONS	DATE	BY
A	REVISED NOTE 6	9/3/08	BHG
B	WIND SPEED TABLE & TRACK CONFIGURATIONS	04/20/12	RLR

MAX SIZE
16' WIDTH
14' HEIGHT
(DOOR HEIGHT SUBJECT TO WEIGHT LIMITATIONS)

DESIGN LOADS
+29.7 PSF
-33.1 PSF

TEST LOADS
+44.6 PSF
-49.7 PSF

LARGE MISSILE IMPACT RESISTANCE

Amarr

165 CARRIAGE COURT WINSTON-SALEM, N.C. 27105 WWW.AMARR.COM

MODEL #600 STRATFORD 1000, 2000
MODEL #650 OAK SUMMIT 1000, 2000
MODEL #950 HERITAGE 1000, 2000
Short, Long, Flush & Oak Summit Panel's

SIZE	DRAWN BY	BHG	DATE	3/06/07	DRAWING NUMBER
B	CHECKED BY	BHG	DATE	3/06/07	IRC-6016-140-24-1

ENGINEER: THOMAS L. SHELMERDINE P.E. LIC. No. 0048579 SHEET 3 OF 3