

THE METHOD OF TESTING WAS IN SUBSTANTIAL CONFORMANCE WITH THE PROCEDURES DESCRIBED IN ASTM E330, E1886, E1996, & F588, DASMA 108 & 115. THE PRESSURES SHOWN ON THE DRAWINGS WERE CALCULATED USING ASCE 7-98/02/05 WITH THE FOLLOWING PARAMETERS (5 FEET OF DOOR WIDTH IN END ZONE, ROOF LESS THAN 10 DEGREES SLOPE, AND I=1.0):

WIND SPEED (MPH)	169	153	146	139	134
EXPOSURE LEVEL	B	C	C	D	D
MEAN ROOF HEIGHT	30'	15'	25'	15'	25'

EDGE OF DOOR 1" OVERLAP ON EACH SIDE

REV	DESCRIPTION OF REVISIONS	DATE	BY
A			

MAX SIZE 12'2" x 24'

DESIGN LOADS +40.2 PSF -46.1 PSF

TEST LOADS +60.3 PSF -69.2 PSF

LARGE MISSILE IMPACT RESISTANCE

Thomas L. Shelmerdine, PE (TX PE #85829) Structural Solutions, PA (TX Firm #004063)

STATE OF TEXAS  
THOMAS L. SHELMERDINE  
85829  
LICENSED PROFESSIONAL ENGINEER

TX

5921-G W. Friendly Ave., Greensboro, NC 27410

**Amarr**

MODEL 2400 AMARR 2402, 2412, 2422  
MODEL 2000 AMARR 2002, 2012, 2022

SIZE	DRAWN BY	RLR	DATE	5/31/16	DRAWING NUMBER
B	CHECKED BY	RLR	DATE	5/31/16	IBC-2412-169-24-1

ENTREMATIC  
165 CARRIAGE COURT WINSTON-SALEM, N.C. 27105

SHEET 1 OF 3

## TRACK CONNECTION DIRECTLY TO STRUCTURE OPTIONS

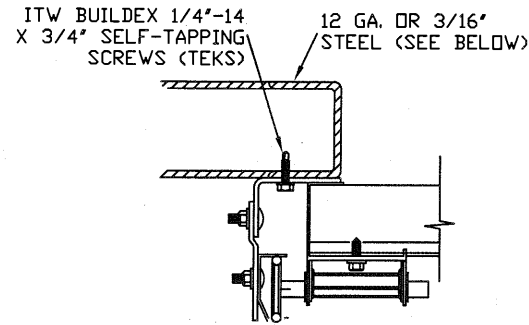

CLIP STYLE REVERSE ANGLE MOUNT SHOWN  
BRACKET, CONTINUOUS AND TAPERED ANGLE  
MOUNT AVAILABLE

**12 GA. STEEL FRAMING**  
232 LBS./SCREW ALLOWABLE LOAD - 6'  
FROM ENDS AND 10' O.C.  
REFER TO NOTES: 1, 2 AND 5

**3/16" STEEL FRAMING**  
569 LBS./SCREW ALLOWABLE LOAD - 6'  
FROM ENDS AND 24' O.C.  
REFER TO NOTES: 1, 2 AND 5

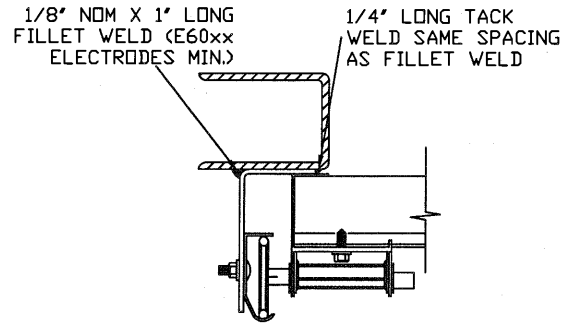

REVERSE ANGLE MOUNT SHOWN  
BRACKET, CONTINUOUS AND  
TAPERED ANGLE MOUNT AVAILABLE

**STEEL FRAMING 12GA OR BETTER**  
1590 LBS./IN. ALLOWABLE LOAD -  
6' FROM ENDS AND 24' O.C.  
REFER TO NOTES: 1, 2, 5, 6, 7, 8  
AND 9

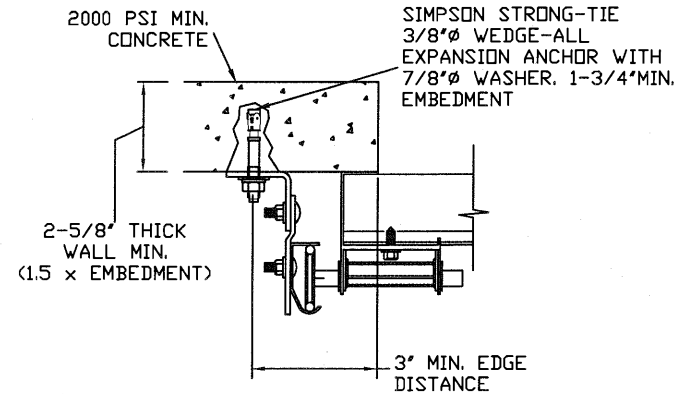

CLIP STYLE CONTINUOUS ANGLE MOUNT SHOWN  
BRACKET, REVERSE AND TAPERED ANGLE MOUNT  
AVAILABLE

**2000 PSI CONCRETE OR GREATER**  
351 LBS./EXPANSION ANCHOR ALLOWABLE  
LOAD - 6' FROM ENDS AND 16' O.C.  
REFER TO NOTES: 1, 2, 3, 4 AND 5

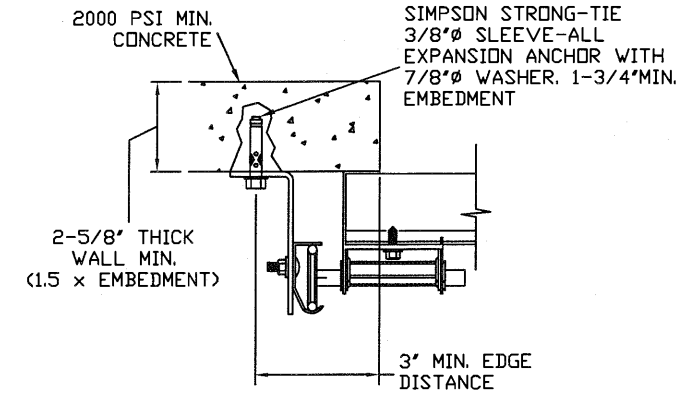

CONTINUOUS ANGLE MOUNT SHOWN  
BRACKET, CONTINUOUS AND TAPERED ANGLE  
MOUNT AVAILABLE

**2000 PSI CONCRETE OR GREATER**  
336 LBS./EXPANSION ANCHOR ALLOWABLE  
LOAD - 6' FROM ENDS AND 16' O.C.  
REFER TO NOTES: 1, 2, 3, 4 AND 5

### SPECIFICATIONS AND NOTES

1. ALL THE LOAD FROM THE DOOR IS TRANSFERRED TO THE VERTICAL TRACK, FROM THE TRACK THE LOAD IS TRANSFERRED TO THE VERTICAL JAMBS. THE HORIZONTAL JAMB OR HEADER RECEIVES NO PORTION OF THE LOAD TRANSFERRED FROM THE DOOR.
2. EACH VERTICAL JAMBS RECEIVES MAXIMUM DESIGN LOADS OF: +244.6 LBS/FT & -280.4 LBS/FT
3. DOOR AND HARDWARE WILL BE DESIGNED, MANUFACTURED AND INSTALLED WITH STANDARDS AS SET FORTH BY DASMA.
4. DOOR SECTIONS SHALL BE 24 GA. (.022) MIN. EXTERIOR SKIN ROLLED FORMED, W/ BAKED ON POLYESTER FINISH
5. DOORS UP TO 24'0" HIGH USE (1) 4.5" 20GA R-TRUSS PER SECTION AND (2) 4.5" 20GA R-TRUSSES ON THE BOTTOM
6. SUPPORTING STRUCTURAL ELEMENTS SHALL BE DESIGNED BY A REGISTERED PROFESSIONAL ENGINEER FOR WIND LOADS INDICATED ON THIS DRAWING IN ADDITION TO OTHER LOADINGS.

## WOOD JAMB ATTACHMENT TO STRUCTURE (OPTIONAL)

### 2 X 6 VERTICAL JAMB ATTACHMENT TO WOOD FRAME STRUCTURE

5/16" X 3" LAG SCREWS STARTING 6" FROM ENDS  
THEN 20" O.C. (1 1/2" EMBEDMENT)

### 2 X 6 VERTICAL JAMB ATTACHMENT TO 2,000 PSI CONCRETE

HILTI KWIK BOLT 3/8" X 4" STARTING 6" FROM ENDS  
THEN 24" O.C. (2 1/2" EMBEDMENT)  
HILTI SLEEVE ANCHOR 3/8" X 2-3/4" STARTING 6" FROM ENDS  
THEN 18" O.C. (1 1/4" EMBEDMENT)  
ITW/RAMSET REDHEAD (TRU-BOLT) 3/8" X 4" STARTING 6" FROM ENDS  
THEN 24" O.C. (2 1/2" EMBEDMENT)

### 2 X 6 VERTICAL JAMB ATTACHMENT TO HOLLOW C-90 BLOCK

SIMPSON 1/4" X 3" TITEN SCREWS STARTING 6" FROM ENDS,  
USE PAIRS OF FASTENERS (3" APART)  
AT 8" O.C. (1 1/2" EMBEDMENT)  
HILTI 1/4" X 2-3/4" KWIK-CON II+ SCREWS STARTING 6" FROM ENDS,  
USE PAIRS OF FASTENERS (3" APART) AT 8" O.C. (1 1/4" EMBEDMENT)

### 2 X 6 VERTICAL JAMB ATTACHMENT TO GROUTED C-90 BLOCK (2000 PSI GROUT)

HILTI SLEEVE ANCHOR 3/8" X 2-3/4" STARTING 6" FROM ENDS  
THEN 20" O.C. (1 1/4" EMBEDMENT)  
(OR, USE FASTENERS FOR HOLLOW C-90 BLOCK)

\*LAGS AND BOLTS CAN BE COUNTERSUNK TO PROVIDE A FLUSH MOUNTING SURFACE.  
\*PREPARATION OF WOOD JAMBS BY OTHERS

### NOTES:

1. ANCHORS TO BE EVENLY SPACED BETWEEN THE HEADER AND FLOOR.
2. FIRST (BOTTOM) ANCHOR STARTING AT NO MORE THAN HALF OF THE MAXIMUM ON-CENTER DISTANCE. HIGHEST ANCHOR INSTALLED AT LEAST AS HIGH AS THE DOOR OPENING.
3. MIN. EDGE DISTANCE OF 3" REQUIRED.
4. USE WASHERS PROVIDED BY THE ANCHOR MANUFACTURER.
5. SUPPORTING STRUCTURAL ELEMENTS SHALL BE DESIGNED BY A REGISTERED PROFESSIONAL ENGINEER FOR WIND LOADS IN ADDITION TO OTHER LOADS.
6. MOST GARAGE DOOR TRACK IS GALVANIZED STEEL. USE ALL NECESSARY PRECAUTIONS WHEN WELDING GALVANIZED STEEL.
7. ALL WELDS SHOULD BE PERFORMED BY A CERTIFIED WELDER OR INSPECTED BY A CERTIFIED WELDING INSPECTOR TO VERIFY THE INTEGRITY OF THE WELD.
8. FILLET WELDS TO HAVE A STRAIGHT OR CONVEX FACE SURFACE.
9. TACK WELD TOE OF ANGLE AT SAME SPACING TO PREVENT ROTATION OF TRACK ANGLE.

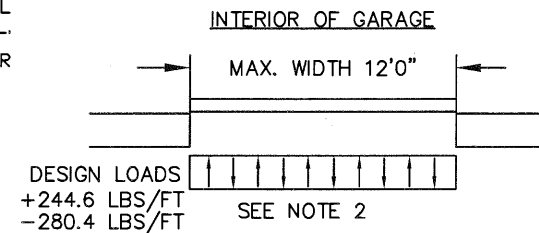

## TRACK CONNECTION TO WOOD JAMB OPTIONS

FOR LAG SCREWS & BRACKET SPACING SEE PAGE 3 FOR TRACK CONFIGURATION DETAIL

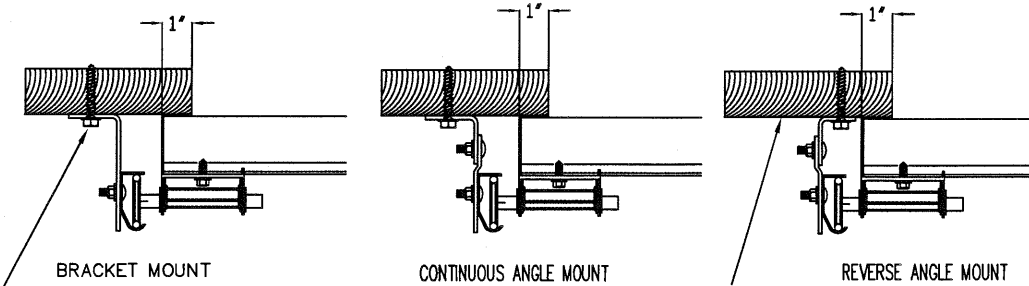

5/16" x 1 5/8" LAG SCREW (1)  
PER JAMB BRACKET (1-1/2"  
EMBEDMENT MINIMUM) (TYP.)

2x6 WOOD JAMB SYP OR SPF  
(NO.2) OR BETTER (TYP.)

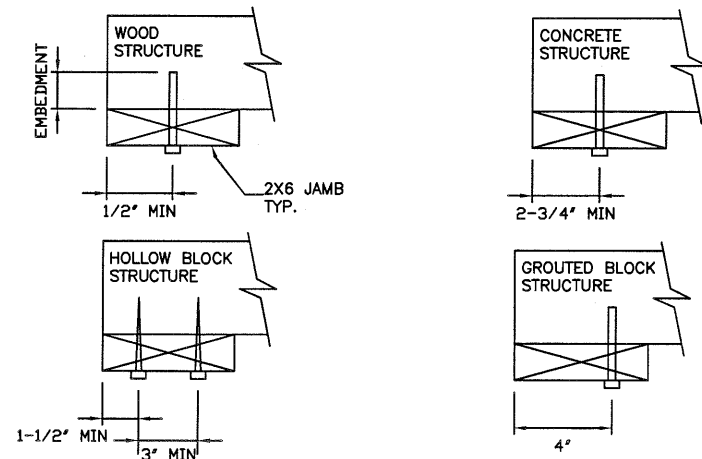

REV	DESCRIPTION OF REVISIONS	DATE	BY
A			
<b>MODEL 2400 AMARR 2402, 2412, 2422</b> <b>MODEL 2000 AMARR 2002, 2012, 2022</b>			
SIZE	DRAWN BY RLR	DATE 5/31/16	DRAWING NUMBER
B	CHECKED BY RLR	DATE 5/31/16	IBC-2412-169-24-I
<small>ENTREMATIC 165 CARRIAGE COURT WINSTON-SALEM, N.C. 27105</small>			SHEET 2 OF 3

5921-G W. Friendly Ave., Greensboro, NC 27410

TABLE 1

Section Width (ft)		Center Stile Locations	
		1st (in)	2nd (in)
6'	0"	36"	-
6'	2"	37"	-
6'	4"	38"	-
6'	6"	39"	-
6'	8"	40"	-
6'	10"	41"	-
7'	0"	42"	-
7'	2"	43"	-
7'	4"	44"	-
7'	6"	45"	-
7'	8"	46"	-
7'	10"	47"	-
8'	0"	48"	-
9'	4"	36"	76"
9'	6"	37"	77"
9'	8"	38"	78"
9'	10"	39"	79"
10'	0"	40"	80"
10'	2"	41"	81"
10'	4"	42"	82"
10'	6"	43"	83"
10'	8"	44"	84"
10'	10"	45"	85"
11'	0"	46"	86"
11'	2"	47"	87"
11'	4"	48"	88"
11'	6"	49"	89"
11'	8"	50"	90"
11'	10"	51"	91"
12'	0"	48"	96"
12'	2"	49"	97"

TABLE 2

DOOR HEIGHT	TRACK ATTACHMENT																				TYPICAL SPLICE			
	A	B	C	D	E	F	G	H	I	J	K	L	M	N	O	P	Q	R	S	T		U	V	W
7' 0"	3.5"	10"	22"	34"	46"	58"																		76"
7' 6"	3.5"	10"	22"	34"	46"	58"																		82"
8' 0"	3.5"	10"	22"	34"	46"	58"	70"																	88"
8' 6"	3.5"	10"	22"	34"	46"	58"	70"	82"																94"
9' 0"	3.5"	10"	22"	34"	46"	58"	70"	82"	94"															100"
9' 6"	3.5"	10"	22"	34"	46"	58"	70"	82"	94"	106"														106"
10' 0"	3.5"	10"	22"	34"	46"	58"	70"	82"	94"	106"	118"													112"
11' 0"	3.5"	10"	22"	34"	46"	58"	70"	82"	94"	106"	118"	130"												124"
12' 0"	3.5"	10"	22"	34"	46"	58"	70"	82"	94"	106"	118"	130"	142"											136"
13' 0"	3.5"	10"	22"	34"	46"	58"	70"	82"	94"	106"	118"	130"	142"	154"										148"
14' 0"	3.5"	10"	22"	34"	46"	58"	70"	82"	94"	106"	118"	130"	142"	154"	166"									160"
15' 0"	3.5"	10"	22"	34"	46"	58"	70"	82"	94"	106"	118"	130"	142"	154"	166"	178"								172"
16' 0"	3.5"	10"	22"	34"	46"	58"	70"	82"	94"	106"	118"	130"	142"	154"	166"	178"	190"							184"
17' 0"	3.5"	10"	22"	34"	46"	58"	70"	82"	94"	106"	118"	130"	142"	154"	166"	178"	190"	202"						196"
18' 0"	3.5"	10"	22"	34"	46"	58"	70"	82"	94"	106"	118"	130"	142"	154"	166"	178"	190"	202"	214"					208"
19' 0"	3.5"	10"	22"	34"	46"	58"	70"	82"	94"	106"	118"	130"	142"	154"	166"	178"	190"	202"	214"	226"				220"
20' 0"	3.5"	10"	22"	34"	46"	58"	70"	82"	94"	106"	118"	130"	142"	154"	166"	178"	190"	202"	214"	226"	238"			232"
21' 0"	3.5"	10"	22"	34"	46"	58"	70"	82"	94"	106"	118"	130"	142"	154"	166"	178"	190"	202"	214"	226"	238"	250"		244"
22' 0"	3.5"	10"	22"	34"	46"	58"	70"	82"	94"	106"	118"	130"	142"	154"	166"	178"	190"	202"	214"	226"	238"	250"	262"	256"
23' 0"	3.5"	10"	22"	34"	46"	58"	70"	82"	94"	106"	118"	130"	142"	154"	166"	178"	190"	202"	214"	226"	238"	250"	262"	268"
24' 0"	3.5"	10"	22"	34"	46"	58"	70"	82"	94"	106"	118"	130"	142"	154"	166"	178"	190"	202"	214"	226"	238"	250"	262"	280"

ALL TRACK ATTACHMENTS +/- 2" ALLOWED USING SYP OR SPF NO.2 OR BETTER ONLY

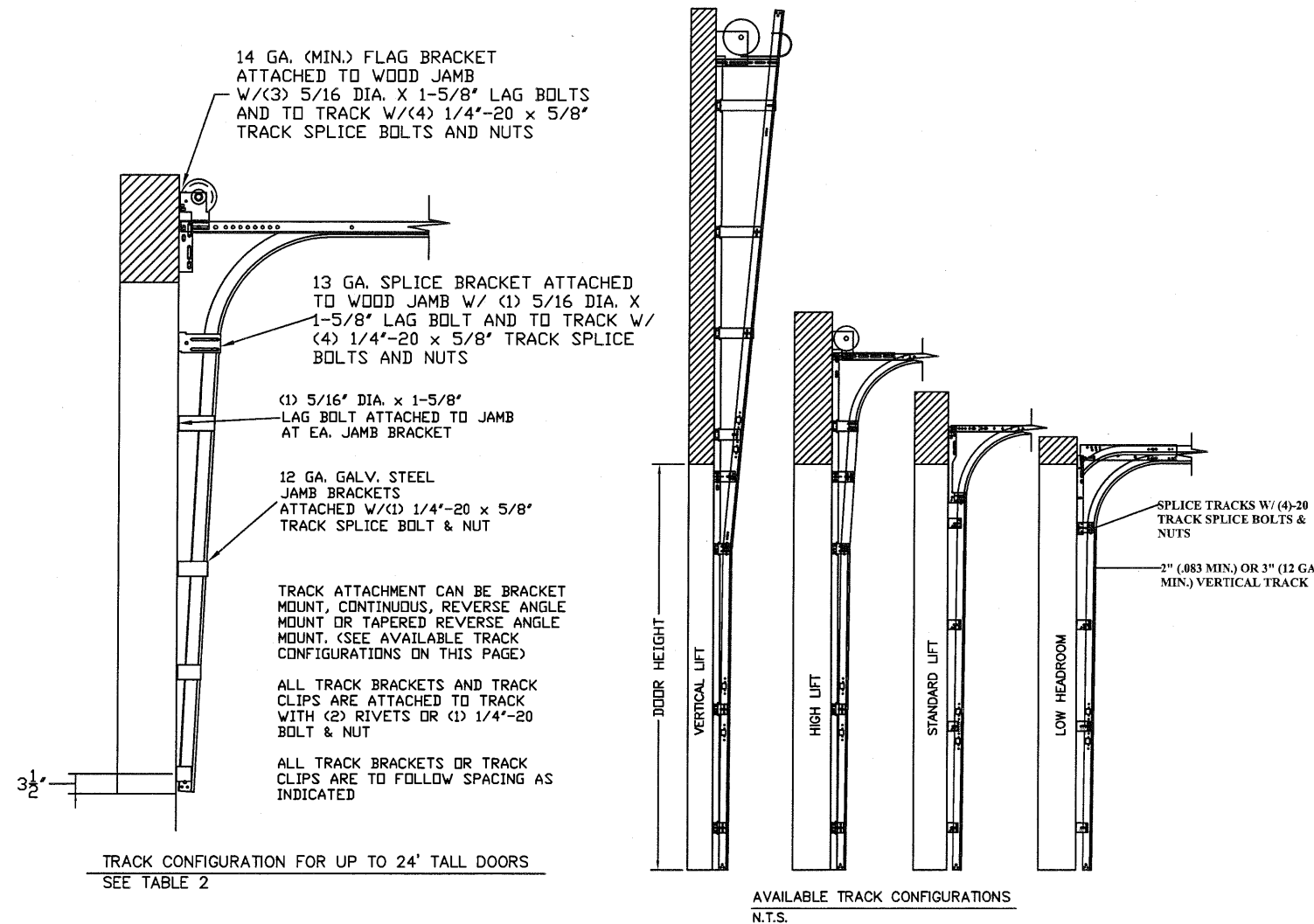

REV	DESCRIPTION OF REVISIONS	DATE	BY
A			

MAX SIZE, 12'2 x 24'

DESIGN LOADS  
+40.2 PSF  
-46.1 PSF

TEST LOADS  
+60.3 PSF  
-69.2 PSF

LARGE MISSILE IMPACT RESISTANCE

Thomas L. Shelmerdine, PE (TX PE #85829)  
Structural Solutions, PA (TX Firm #F-004063)

STATE OF TEXAS  
THOMAS L. SHELMERDINE  
85829  
LICENSED PROFESSIONAL ENGINEER  
TX

5921-G.W. Friendly Ave., Greensboro, NC 27410

**Amarr**

MODEL 2400 AMARR 2402, 2412, 2422  
MODEL 2000 AMARR 2002, 2012, 2022

SIZE	DRAWN BY	RLR	DATE	5/31/16	DRAWING NUMBER
B	CHECKED BY	RLR	DATE	5/31/16	IBC-2412-169-24-1

ENTREMATIC  
165 CARRIAGE COURT WINSTON-SALEM, N.C. 27105

SHEET 3 OF 3