

TYPICAL TOP FIXTURES  
N.T.S. 1

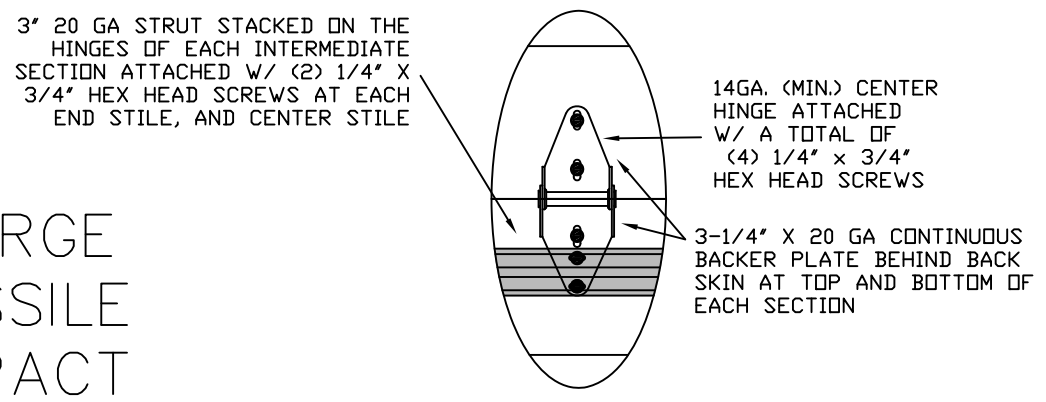

TYPICAL CENTER HINGE  
N.T.S. 2

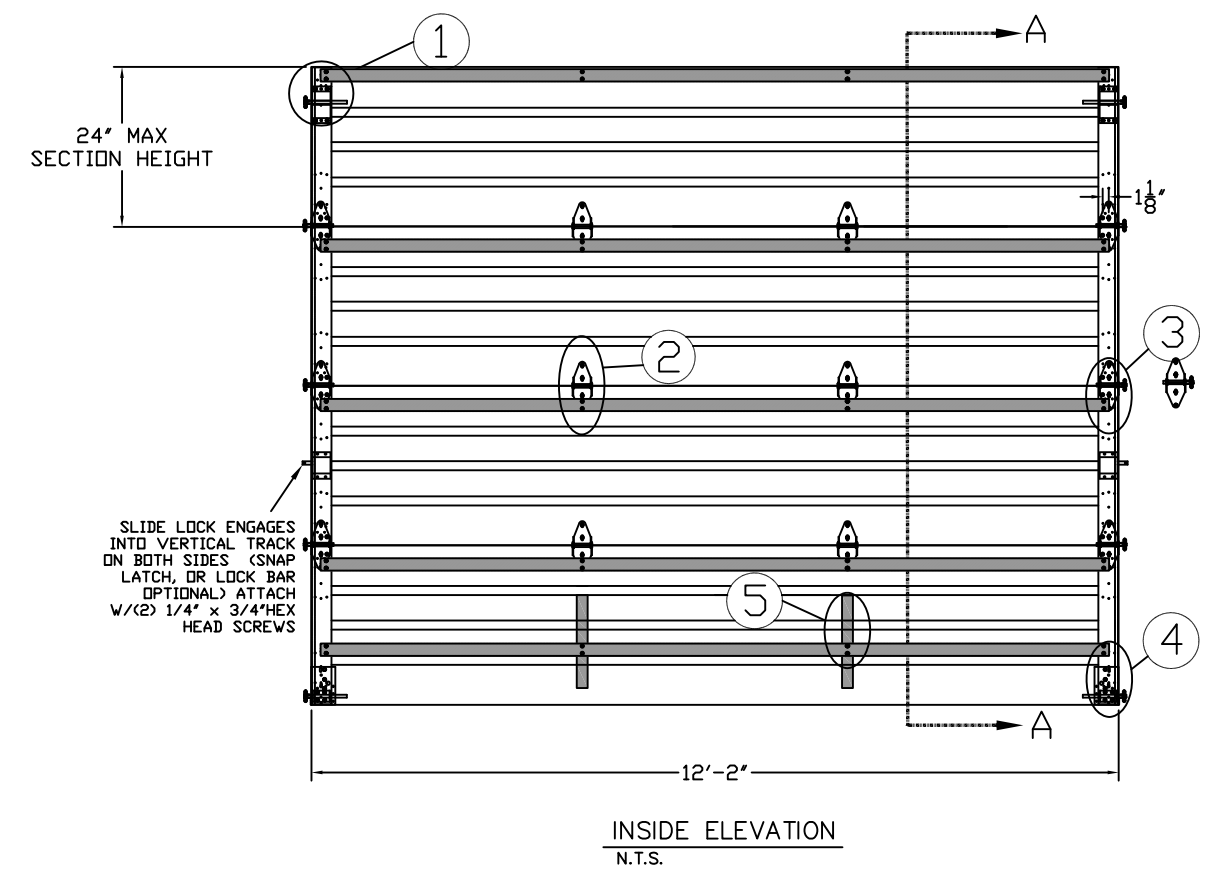

INSIDE ELEVATION  
N.T.S.

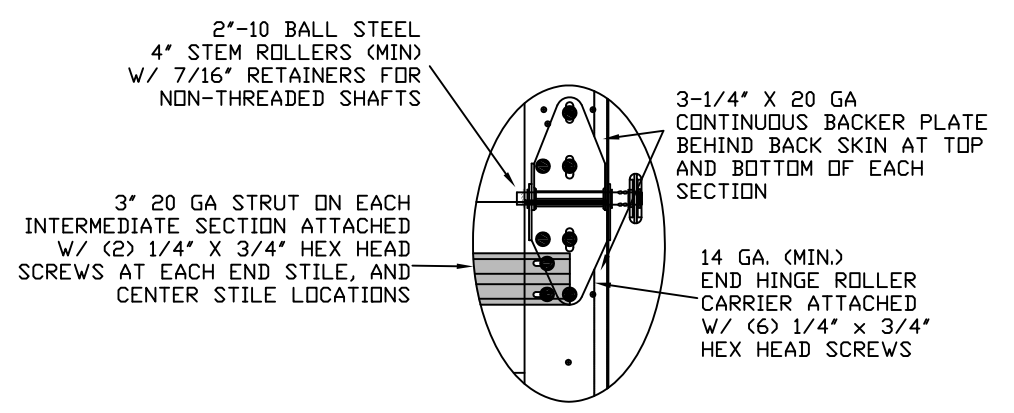

TYPICAL END HINGE  
N.T.S. 3

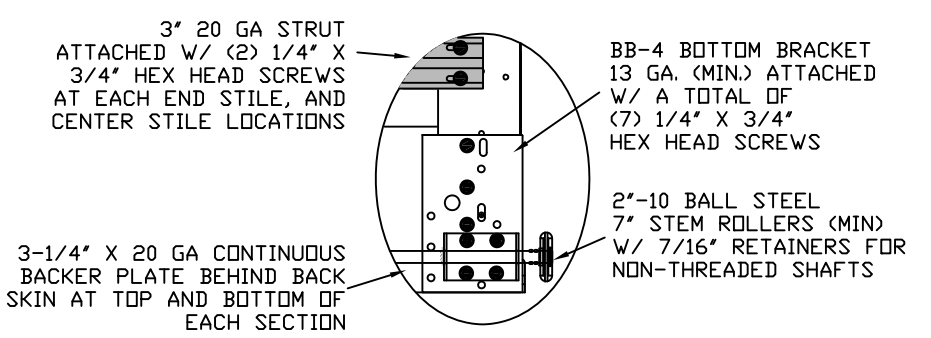

TYPICAL BOTTOM BRACKET  
N.T.S. 4

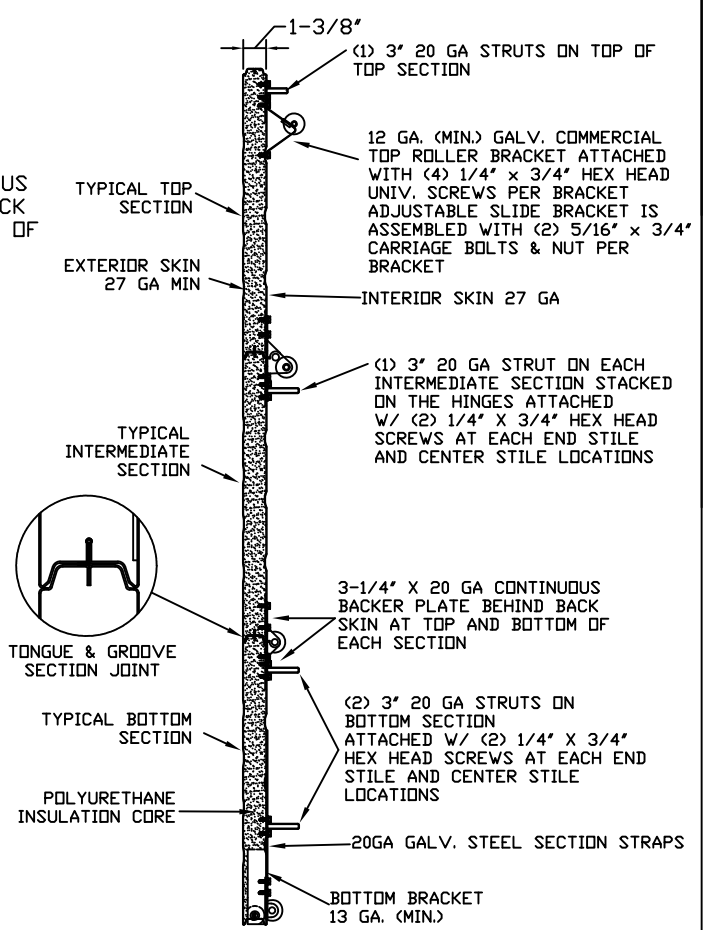

SECTION A-A (SIDE VIEW)

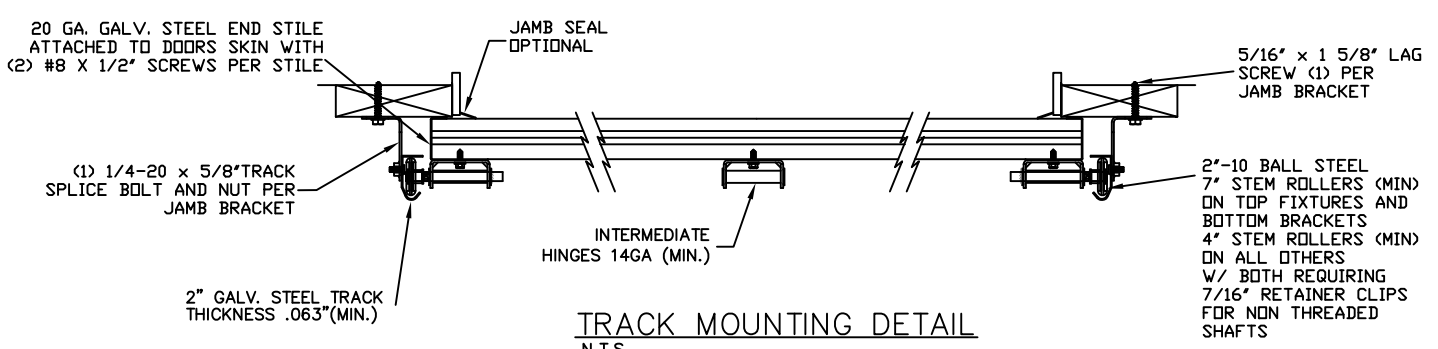

TRACK MOUNTING DETAIL  
N.T.S.  
EDGE OF DOOR 1" OVERLAP ON EACH SIDE

# LARGE MISSILE IMPACT RESISTANCE

THE METHOD OF TESTING WAS IN SUBSTANTIAL CONFORMANCE WITH THE PROCEDURES DESCRIBED IN, ANSI/DASMA 115, ASTM E1886, ASTM E1996 AND ASTM F588. THE PRESSURES SHOWN ON THE DRAWINGS WERE CALCULATED USING ASCE 7-98/02/05 WITH THE FOLLOWING PARAMETERS (5 FEET OF DOOR WIDTH IN END ZONE, ROOF SLOPE 10° OR LESS):

WIND SPEED (MPH)	130	118	112	107	103
EXPOSURE LEVEL	B	C	C	D	D
MEAN ROOF HEIGHT	30'	15'	25'	15'	25'

REV	DESCRIPTION OF REVISIONS	DATE	BY

MAX SIZE 12'2" x 24'  
 DESIGN LOADS +23.8 PSF -27.3 PSF  
 TEST LOADS +35.7 PSF -41.0 PSF  
 LARGE MISSILE IMPACT RESISTANCE



165 CARRIAGE COURT WINSTON-SALEM, N.C. 27105 WWW.AMARR.COM

MODEL 1350 (1-3/8"), MODEL 2700 (2")  
FLUSH AND RIBBED PANEL

SIZE	DRAWN BY	RLR	DATE	05/18/12	DRAWING NUMBER
B	CHECKED BY		DATE		IBC-1312-130-15-1

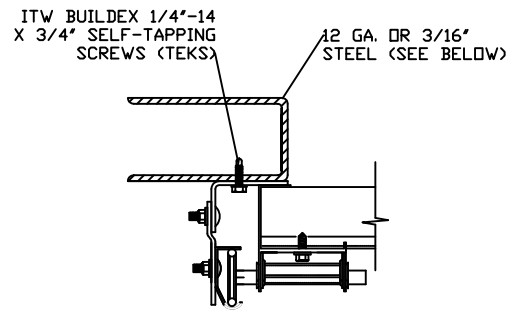

REVERSE ANGLE MOUNT SHOWN  
BRACKET, CONTINUOUS AND TAPERED  
ANGLE MOUNT AVAILABLE

12 GA STEEL FRAMING  
232 LBS/SCREW ALLOWABLE LOAD - 6' FROM ENDS AND 18' O.C.  
REFER TO NOTES: 1, 2 AND 5

3/16\"/>STEEL FRAMING  
569 LBS/SCREW ALLOWABLE LOAD - 6' FROM ENDS AND 24' O.C.  
REFER TO NOTES: 1, 2 AND 5

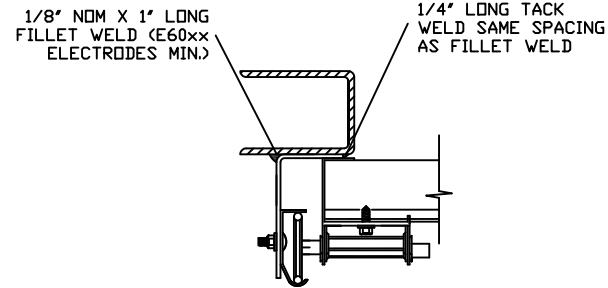

TAPERED REVERSE ANGLE MOUNT SHOWN  
BRACKET, CONTINUOUS AND REVERSE  
ANGLE MOUNT AVAILABLE

STEEL FRAMING 12GA OR GREATER  
1590 LBS/in ALLOWABLE LOAD - 6' FROM ENDS AND 24' O.C.  
REFER TO NOTES: 1, 2, 5, 6, 7, 8 AND 9

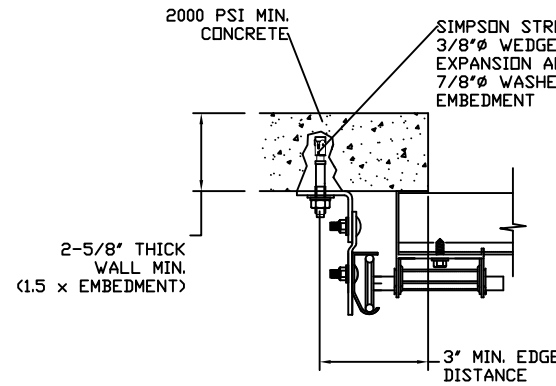

CONTINUOUS ANGLE MOUNT SHOWN  
BRACKET MOUNT AVAILABLE

2000 PSI CONCRETE OR GREATER  
351 LBS/EXPANSION ANCHOR ALLOWABLE LOAD - 6' FROM ENDS AND 24' O.C.  
REFER TO NOTES: 1, 2, 3, 4 AND 5

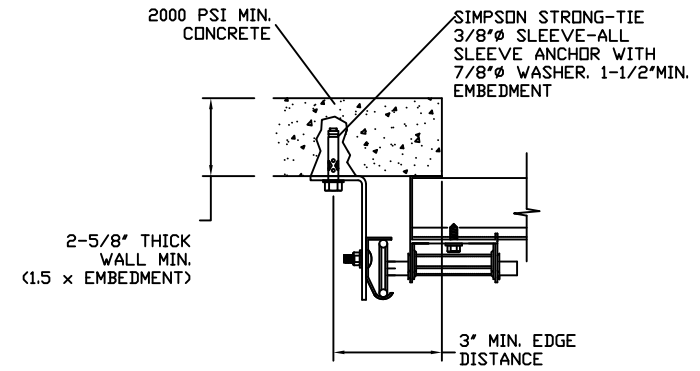

BRACKET MOUNT SHOWN  
CONTINUOUS MOUNT AVAILABLE

2000 PSI CONCRETE OR GREATER  
336 LBS/SLEEVE ANCHOR ALLOWABLE LOAD - 6' FROM ENDS AND 24' O.C.  
REFER TO NOTES: 1, 2, 3, 4 AND 5

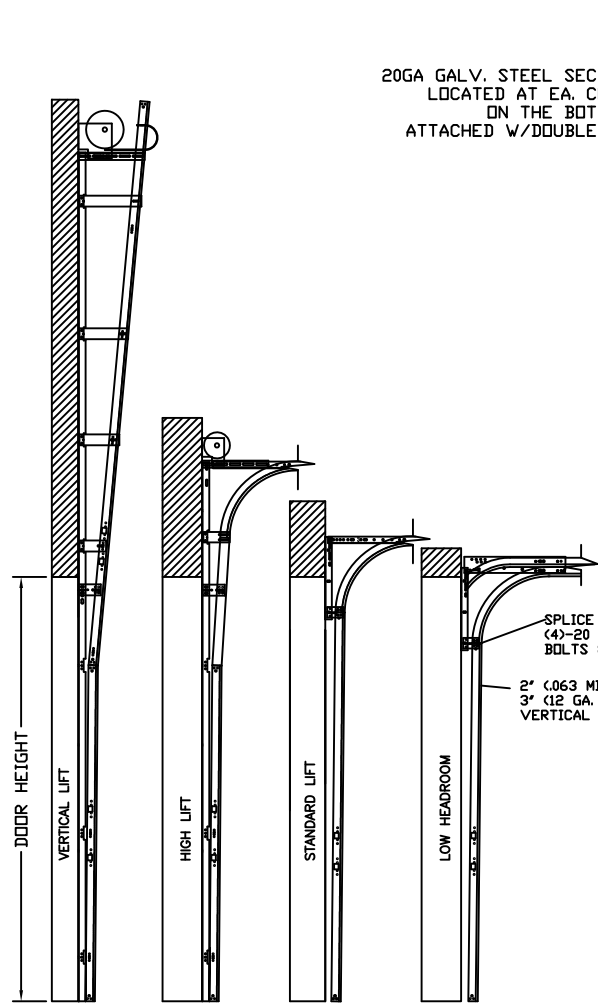

AVAILABLE TRACK CONFIGURATIONS  
N.T.S.

20GA GALV. STEEL SECTION STRAPS  
LOCATED AT EA. CENTER HINGE  
ON THE BOTTOM SECTION  
ATTACHED W/DOUBLE SIDED TAPE

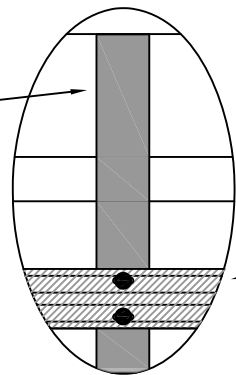

SECTION STRAP ATTACHMENT 5  
N.T.S.

NOTES:

1. ANCHORS TO BE EVENLY SPACED BETWEEN THE HEADER AND FLOOR.
2. FIRST (BOTTOM) ANCHOR STARTING AT NO MORE THAN HALF OF THE MAXIMUM ON-CENTER DISTANCE. HIGHEST ANCHOR INSTALLED AT LEAST AS HIGH AS THE DOOR OPENING.
3. MIN. EDGE DISTANCE OF 3\"/>REQUIRED.
4. USE WASHERS PROVIDED BY THE ANCHOR MANUFACTURER.
5. SUPPORTING STRUCTURAL ELEMENTS SHALL BE DESIGNED BY A REGISTERED PROFESSIONAL ENGINEER FOR WIND LOADS IN ADDITION TO OTHER LOADS.
6. MOST GARAGE DOOR TRACK IS GALVANIZED STEEL. USE ALL NECESSARY PRECAUTIONS WHEN WELDING GALVANIZED STEEL.
7. ALL WELDS SHOULD BE PERFORMED BY A CERTIFIED WELDER OR INSPECTED BY A CERTIFIED WELDING INSPECTOR TO VERIFY THE INTEGRITY OF THE WELD.
8. FILLET WELDS TO HAVE A STRAIGHT OR CONVEX FACE SURFACE.
9. TACK WELD TOE OF ANGLE AT SAME SPACING TO PREVENT ROTATION OF TRACK ANGLE.

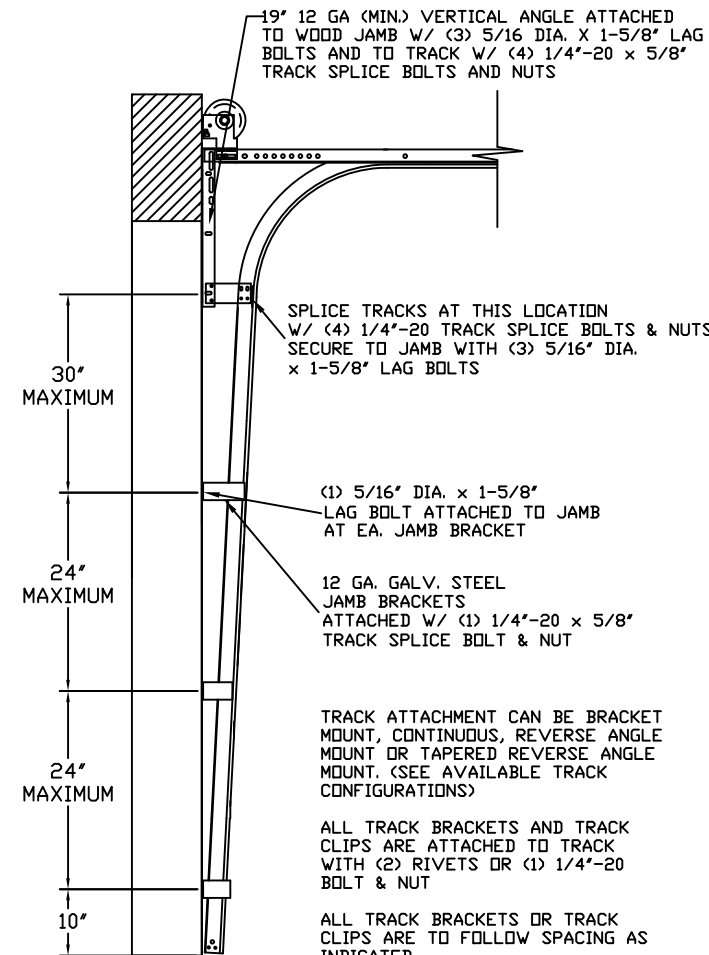

TRACK CONFIGURATION FOR 6' UP TO 24' TALL DOORS

REV	DESCRIPTION OF REVISIONS	DATE	BY

MAX SIZE  
12'2" x 24'  
DESIGN LOADS  
+23.8 PSF  
-27.3 PSF  
TEST LOADS  
+35.7 PSF  
-41.0 PSF  
LARGE MISSILE  
IMPACT  
RESISTANCE

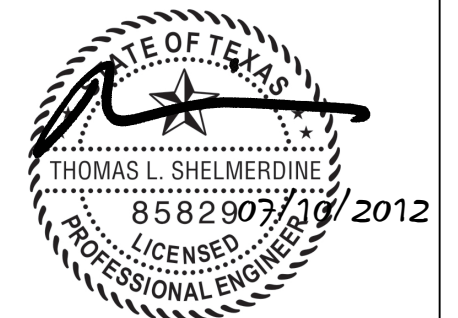

**Amarr**

165 CARRIAGE COURT WINSTON-SALEM, N.C. 27105 WWW.AMARR.COM

MODEL 1350 (1-3/8"), MODEL 2700 (2")  
FLUSH AND RIBBED PANEL

SIZE	DRAWN BY	RLR	DATE	05/18/12	DRAWING NUMBER
B	CHECKED BY		DATE		IBC-1312-130-15-1
ENGINEER: THOMAS L. SHELMEARDINE P.E. LIC. No. 0048579					SHEET 2 OF 3

# TRACK CONNECTION TO WOOD JAMB OPTIONS

FOR LAG SCREWS & BRACKET SPACING SEE SHEET 2 TRACK CONFIGURATION DETAIL

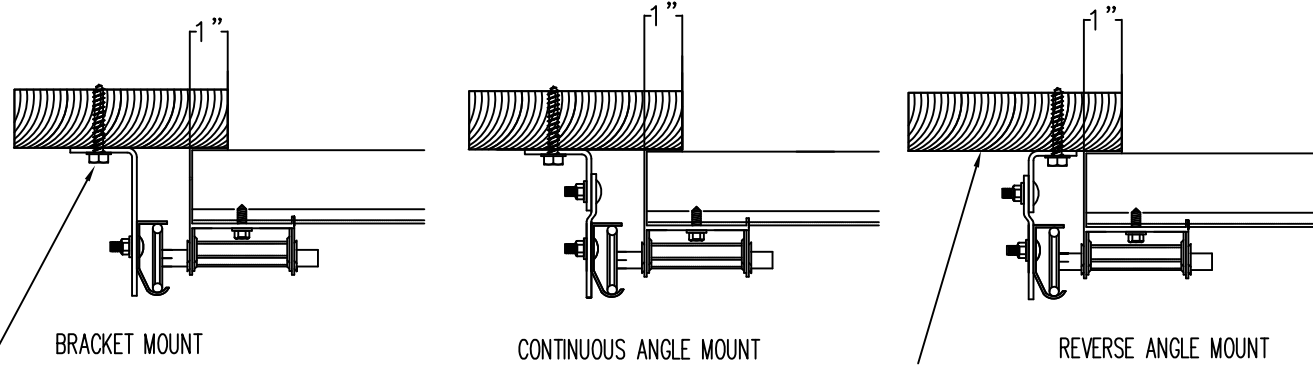

5/16" x 1 5/8" LAG SCREW (1)  
PER JAMB BRACKET (1-1/2"  
EMBEDMENT MINIMUM) (TYP.)

2x6 WOOD JAMB SYP OR SPF  
(NO.2) OR BETTER (TYP.)

TABLE 1

Section Width (ft)	Center Stile Locations (Measured from Left Edge)	
	1st (in)	2nd (in)
9' 2"	37.000	73.000
9' 4"	36.000	76.000
9' 6"	37.000	77.000
9' 8"	38.000	78.000
9' 10"	39.000	79.000
10' 0"	40.000	80.000
10' 2"	41.000	81.000
10' 4"	42.000	82.000
10' 6"	43.000	83.000
10' 8"	44.000	84.000
10' 10"	45.000	85.000
11' 0"	46.000	86.000
11' 2"	47.000	87.000
11' 4"	48.000	88.000
11' 6"	49.000	89.000
11' 8"	50.000	90.000
11' 10"	51.000	91.000
12' 0"	48.000	96.000
12' 2"	49.000	97.000

## WOOD JAMB ATTACHMENT TO STRUCTURE (OPTIONAL)

- 2 X 6 VERTICAL JAMB ATTACHMENT TO WOOD FRAME STRUCTURE**  
5/16" x 3" LAG SCREWS STARTING 6" FROM ENDS THEN 24" O.C. (1 1/2" EMBEDMENT)
- 2 X 6 VERTICAL JAMB ATTACHMENT TO 2,000 PSI CONCRETE**  
HILTI KWIK BOLT 3/8" x 4" STARTING 6" FROM ENDS THEN 24" O.C. (2 1/2" EMBEDMENT)  
HILTI SLEEVE ANCHOR 3/8" x 2-3/4" STARTING 6" FROM ENDS THEN 24" O.C. (1 1/4" EMBEDMENT)  
ITW/RAMSET REDHEAD (TRU-BOLT) 3/8" x 4" STARTING 6" FROM ENDS THEN 24" O.C. (2 1/2" EMBEDMENT)
- 2 X 6 VERTICAL JAMB ATTACHMENT TO HOLLOW C-90 BLOCK**  
SIMPSON 1/4" x 3" TITEN SCREWS STARTING 6" FROM ENDS, USE PAIRS OF FASTENERS (3" APART) AT 24" O.C. (1 1/2" EMBEDMENT)  
HILTI 1/4" x 2-3/4" KWIK-CON II+ SCREWS STARTING 6" FROM ENDS, USE PAIRS OF FASTENERS (3" APART) AT 24" O.C. (1 1/4" EMBEDMENT)
- 2 X 6 VERTICAL JAMB ATTACHMENT TO GROUTED C-90 BLOCK (2000 PSI GROUT)**  
HILTI SLEEVE ANCHOR 3/8" x 2-3/4" STARTING 6" FROM ENDS THEN 24" O.C. (1 1/4" EMBEDMENT) (OR, USE FASTENERS FOR HOLLOW C-90 BLOCK)

\*LAGS AND BOLTS CAN BE COUNTERSUNK TO PROVIDE A FLUSH MOUNTING SURFACE.  
\*PREPARATION OF WOOD JAMBS BY OTHERS

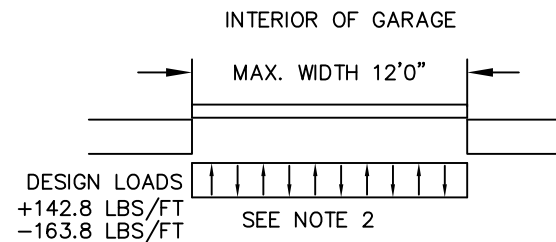
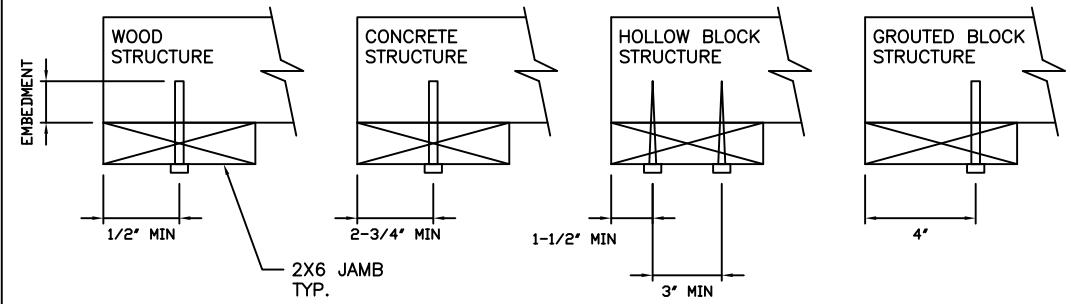

### SPECIFICATIONS AND NOTES

- ALL THE LOAD FROM THE DOOR IS TRANSFERRED TO THE VERTICAL TRACK, FROM THE TRACK THE LOAD IS TRANSFERRED TO THE VERTICAL JAMBS. THE HORIZONTAL JAMB OR HEADER RECEIVES NO PORTION OF THE LOAD TRANSFERRED FROM THE DOOR.
- EACH VERTICAL JAMBS RECEIVES MAXIMUM DESIGN LOADS OF: +142.8 LBS/FT & -163.8 LBS/FT
- DOOR AND HARDWARE WILL BE DESIGNED, MANUFACTURED AND INSTALLED WITH STANDARDS AS SET FORTH BY DASMA.
- DOOR SECTIONS SHALL BE 27 GA MIN. INTERIOR AND EXTERIOR SKIN ROLLED FORMED, W/ BAKED ON POLYESTER FINISH
- DOORS UP TO 24'0" HIGH REQUIRE (2) 3" 20 GA STRUTS ON BOTTOM, (1) 3" 20 GA STRUT ON EACH INTERMEDIATE, AND (1) 3" 20 GA STRUT ON THE TOP SECTION.
- SUPPORTING STRUCTURAL ELEMENTS SHALL BE DESIGNED BY A REGISTERED PROFESSIONAL ENGINEER FOR WIND LOADS INDICATED ON THIS DRAWING IN ADDITION TO OTHER LOADINGS.

REV	DESCRIPTION OF REVISIONS	DATE	BY

MAX SIZE  
12'2" x 24'

DESIGN LOADS  
+23.8 PSF  
-27.3 PSF

TEST LOADS  
+35.7 PSF  
-41.0 PSF

LARGE MISSILE  
IMPACT  
RESISTANCE

**Amarr**  
165 CARRIAGE COURT WINSTON-SALEM, N.C. 27105 WWW.AMARR.COM

**MODEL 1350 (1-3/8"), MODEL 2700 (2")  
FLUSH AND RIBBED PANEL**

SIZE	DRAWN BY	RLR	DATE	05/18/12	DRAWING NUMBER
B	CHECKED BY		DATE		IBC-1312-130-15-1

ENGINEER: THOMAS L. SHELME RDINE P.E. LIC. No. 0048579 SHEET 3 OF 3