

**LARGE MISSILE IMPACT RESISTANT**

THE METHOD OF TESTING WAS IN SUBSTANTIAL CONFORMANCE WITH THE PROCEDURE DESCRIBED IN DASMA 108-05 & 115-05, AND ASTM E330-02, E1886-05, E1996-09, & F588-07. THE PRESSURES SHOWN ON THE DRAWINGS WERE CALCULATED USING ASCE 7-05 WITH THE FOLLOWING PARAMETERS (5 FEET OF DOOR WIDTH IN THE END ZONE, ROOF LESS THAN OR EQUAL TO 10 DEGREES SLOPE I=1.0):

WIND SPEED (MPH)	151	137	130	124	119
EXPOSURE LEVEL	B	C	C	D	D
MEAN ROOF HEIGHT	30'	15'	25'	15'	25'

REV	DESCRIPTION OF REVISIONS	DATE	BY

MAX SIZE 16'2" x 24'

DESIGN LOADS +31.2 PSF -35.3 PSF

TEST LOADS +46.8 PSF -53.0 PSF

LARGE MISSILE IMPACT RESISTANCE

Thomas L. Shelmerdine, PE (TX PE #85829) Structural Solutions, PA (TX Firm #F-004063)

STATE OF TEXAS  
THOMAS L. SHELMERDINE  
85829  
LICENSED PROFESSIONAL ENGINEER

TX

5921-G.W. Friendly Ave., Greensboro, NC 27410

**Amarr**  
ENTREMATIC

**MODEL 1000 AMARR 2432**

SIZE	DRAWN BY	DRD	DATE	11/18/16	DRAWING NUMBER
B	CHECKED BY	RLR	DATE	12/05/16	IBC-1016-150-26-1

ENTREMATIC  
165 CARRIAGE COURT WINSTON-SALEM, N.C. 27105

SHEET 1 OF 4

## TRACK CONNECTION DIRECTLY TO STRUCTURE OPTIONS

ITW BUILDDEX 1/4"-14 X 3/4" SELF-TAPPING SCREWS (TEKS)

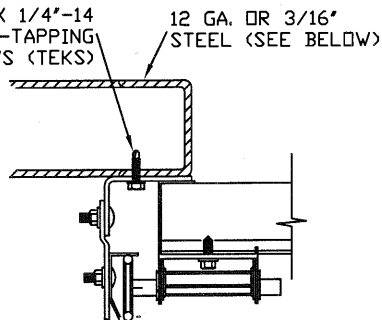

CLIP STYLE REVERSE ANGLE MOUNT SHOWN  
BRACKET, CONTINUOUS AND TAPERED ANGLE MOUNT AVAILABLE

**12 GA. STEEL FRAMING**  
232 LBS./SCREW ALLOWABLE LOAD - 6' FROM ENDS AND 10' O.C.  
REFER TO NOTES: 1, 2 AND 5

**3/16" STEEL FRAMING**  
569 LBS./SCREW ALLOWABLE LOAD - 6' FROM ENDS AND 24' O.C.  
REFER TO NOTES: 1, 2 AND 5

1/8" NDM X 1" LONG FILLET WELD (E60xx ELECTRODES MIN.)

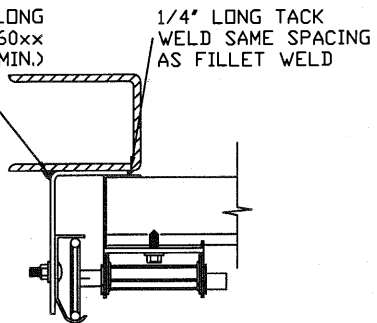

REVERSE ANGLE MOUNT SHOWN  
BRACKET, CONTINUOUS AND TAPERED ANGLE MOUNT AVAILABLE

**STEEL FRAMING 12GA OR BETTER**  
1590 LBS./IN. ALLOWABLE LOAD - 6' FROM ENDS AND 24' O.C.  
REFER TO NOTES: 1, 2, 5, 6, 7, 8 AND 9

2000 PSI MIN. CONCRETE

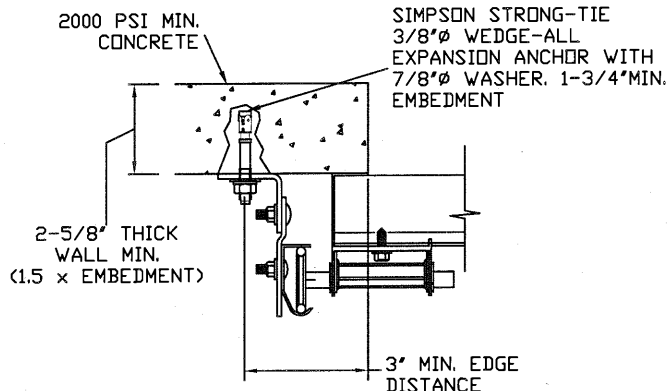

CLIP STYLE CONTINUOUS ANGLE MOUNT SHOWN  
BRACKET, REVERSE AND TAPERED ANGLE MOUNT AVAILABLE

**2000 PSI CONCRETE OR GREATER**  
351 LBS./EXPANSION ANCHOR ALLOWABLE LOAD - 6' FROM ENDS AND 16' O.C.  
REFER TO NOTES: 1, 2, 3, 4 AND 5

2000 PSI MIN. CONCRETE

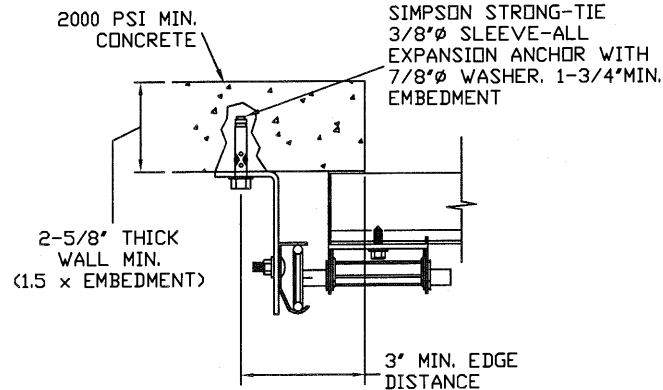

CONTINUOUS ANGLE MOUNT SHOWN  
BRACKET, CONTINUOUS AND TAPERED ANGLE MOUNT AVAILABLE

**2000 PSI CONCRETE OR GREATER**  
336 LBS./EXPANSION ANCHOR ALLOWABLE LOAD - 6' FROM ENDS AND 16' O.C.  
REFER TO NOTES: 1, 2, 3, 4 AND 5

## WOOD JAMB ATTACHMENT TO STRUCTURE (OPTIONAL)

### 2 X 6 VERTICAL JAMB ATTACHMENT TO WOOD FRAME STRUCTURE

5/16" X 3" LAG SCREWS STARTING 6" FROM ENDS THEN 18" O.C. (1 1/2" EMBEDMENT)

### 2 X 6 VERTICAL JAMB ATTACHMENT TO 2,000 PSI CONCRETE

HILTI KWIK BOLT 3/8" X 4" STARTING 6" FROM ENDS THEN 24" O.C. (2 1/2" EMBEDMENT)  
HILTI SLEEVE ANCHOR 3/8" X 2-3/4" STARTING 6" FROM ENDS THEN 16" O.C. (1 1/4" EMBEDMENT)  
ITW/RAMSET REDHEAD (TRU-BOLT) 3/8" X 4" STARTING 6" FROM ENDS THEN 24" O.C. (2 1/2" EMBEDMENT)

### 2 X 6 VERTICAL JAMB ATTACHMENT TO HOLLOW C-90 BLOCK

SIMPSON 1/4" X 3" TITEN SCREWS STARTING 6" FROM ENDS, USE PAIRS OF FASTENERS (3" APART) AT 8" O.C. (1 1/2" EMBEDMENT)  
HILTI 1/4" X 2-3/4" KWIK-CON II+ SCREWS STARTING 6" FROM ENDS, USE PAIRS OF FASTENERS (3" APART) AT 8" O.C. (1 1/4" EMBEDMENT)

### 2 X 6 VERTICAL JAMB ATTACHMENT TO GROUTED C-90 BLOCK (2000 PSI GROUT)

HILTI SLEEVE ANCHOR 3/8" X 2-3/4" STARTING 6" FROM ENDS THEN 20" O.C. (1 1/4" EMBEDMENT)  
(OR, USE FASTENERS FOR HOLLOW C-90 BLOCK)  
\*LAGS AND BOLTS CAN BE COUNTERSUNK TO PROVIDE A FLUSH MOUNTING SURFACE.  
\*PREPARATION OF WOOD JAMBS BY OTHERS

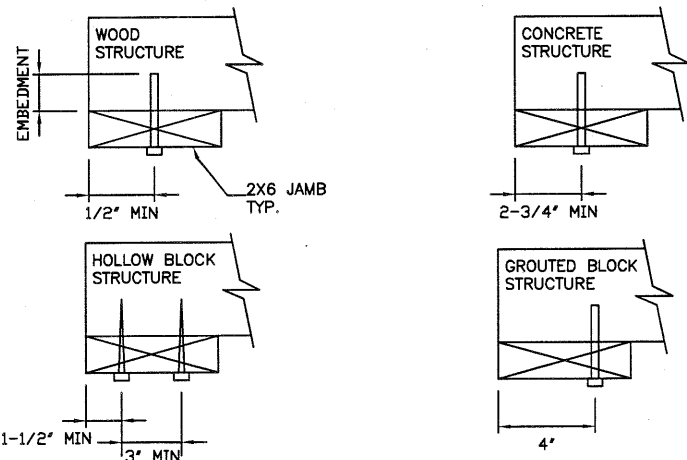

### NOTES:

- ANCHORS TO BE EVENLY SPACED BETWEEN THE HEADER AND FLOOR.
- FIRST (BOTTOM) ANCHOR STARTING AT NO MORE THAN HALF OF THE MAXIMUM ON-CENTER DISTANCE. HIGHEST ANCHOR INSTALLED AT LEAST AS HIGH AS THE DOOR OPENING.
- MIN. EDGE DISTANCE OF 3' REQUIRED.
- USE WASHERS PROVIDED BY THE ANCHOR MANUFACTURER.
- SUPPORTING STRUCTURAL ELEMENTS SHALL BE DESIGNED BY A REGISTERED PROFESSIONAL ENGINEER FOR WIND LOADS IN ADDITION TO OTHER LOADS.
- MOST GARAGE DOOR TRACK IS GALVANIZED STEEL. USE ALL NECESSARY PRECAUTIONS WHEN WELDING GALVANIZED STEEL.
- ALL WELDS SHOULD BE PERFORMED BY A CERTIFIED WELDER OR INSPECTED BY A CERTIFIED WELDING INSPECTOR TO VERIFY THE INTEGRITY OF THE WELD.
- FILLET WELDS TO HAVE A STRAIGHT OR CONVEX FACE SURFACE.
- TACK WELD TOE OF ANGLE AT SAME SPACING TO PREVENT ROTATION OF TRACK ANGLE.

## TRACK CONNECTION TO WOOD JAMB OPTIONS

FOR LAG SCREWS & BRACKET SPACING SEE TABLE 1 ON PAGE 4

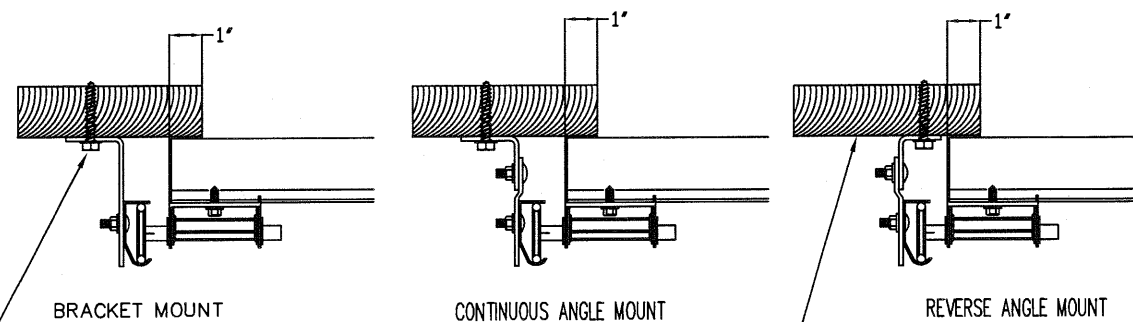

5/16" x 1 5/8" LAG SCREW (1 PER JAMB BRACKET (1-1/2" EMBEDMENT MINIMUM) (TYP.))

2x6 WOOD JAMB SYP OR SPF (NO.2) OR BETTER (TYP.)

REV	DESCRIPTION OF REVISIONS	DATE	BY
	MAX SIZE 16'2 x 24'		
	DESIGN LOADS +31.2 PSF -35.3 PSF		
	TEST LOADS +46.8 PSF -53.0 PSF		
	LARGE MISSILE IMPACT RESISTANCE		

Thomas L. Shelmerdine, PE (TX PE #85829)  
Structural Solutions, PA (TX Firm #004063)

TX

5921-G W. Friendly Ave., Greensboro, NC 27410

**Amarr**  
ENTREMATICS

**MODEL 1000 AMARR 2432**

SIZE	DRAWN BY	DRD	DATE	11/18/16	DRAWING NUMBER
B	CHECKED BY	RLR	DATE	12/05/16	IEC-1016-150-26-1
ENTREMATICS 165 CARRIAGE COURT WINSTON-SALEM, N.C. 27105					SHEET 2 OF 4

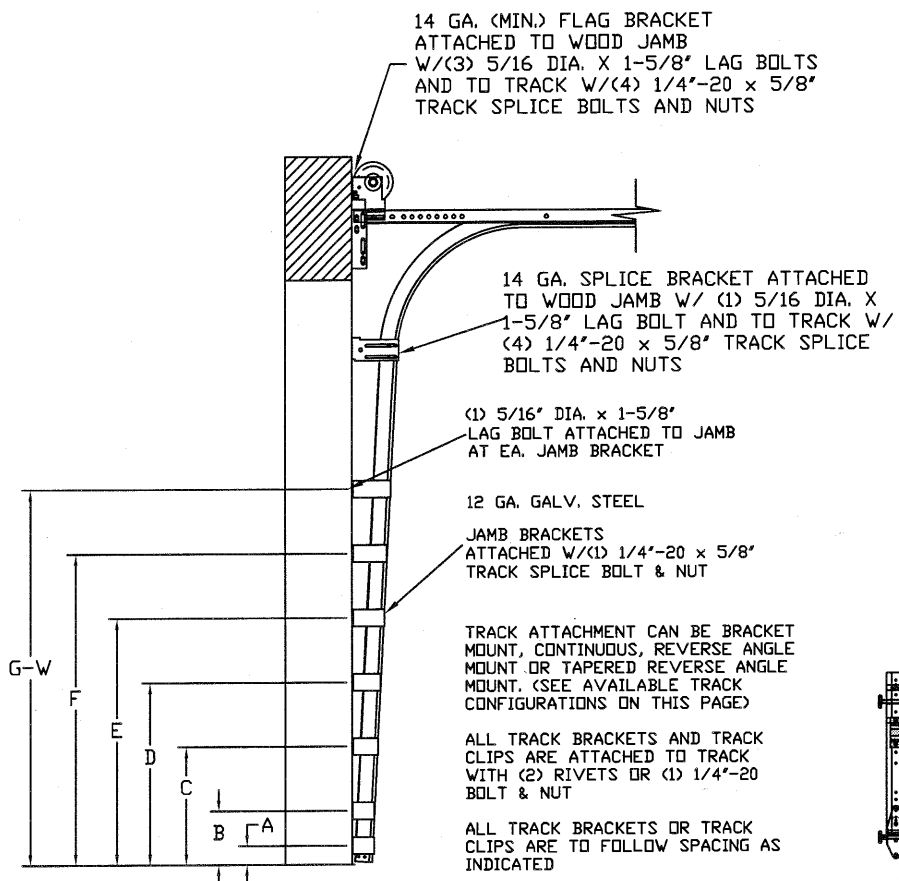

TRACK CONFIGURATION FOR UP TO 24' TALL DOORS  
SEE TABLE 1 ON PAGE 4

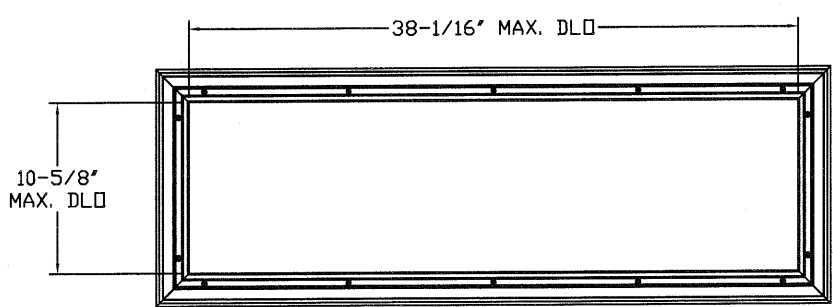

LONG PANEL IMPACT GLAZING FASTENER DETAIL  
N.T.S.

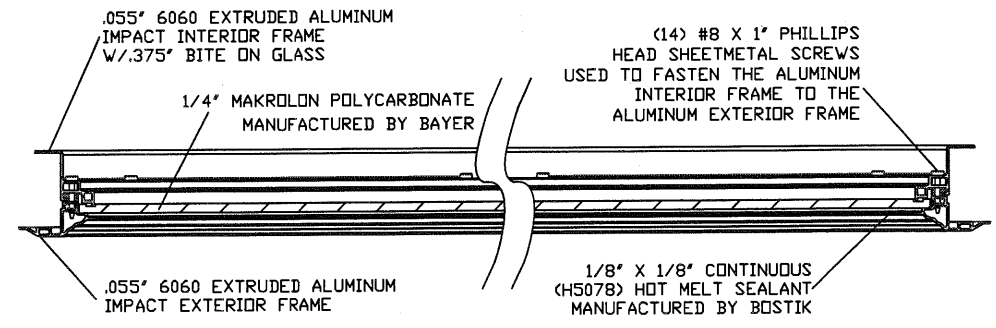

SECTION B-B IMPACT WINDOW DETAIL  
N.T.S.

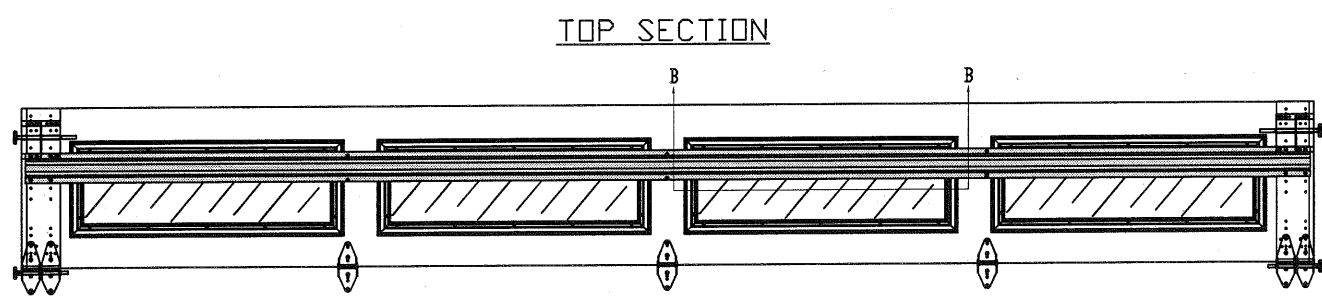

OPTIONAL GLAZED SECTION W/LONG PANEL IMPACT WINDOWS  
N.T.S.

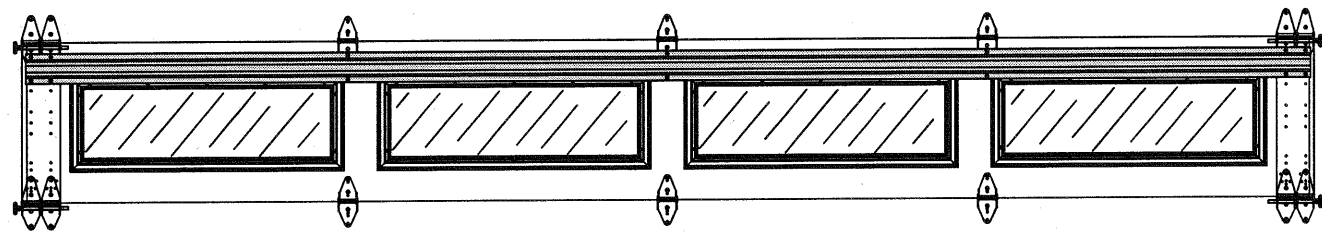

OPTIONAL GLAZED SECTION W/LONG PANEL IMPACT WINDOWS  
N.T.S.

**SPECIFICATIONS AND NOTES**

1. ALL THE LOAD FROM THE DOOR IS TRANSFERRED TO THE VERTICAL TRACK, FROM THE TRACK THE LOAD IS TRANSFERRED TO THE VERTICAL JAMBS. THE HORIZONTAL JAMB OR HEADER RECEIVES NO PORTION OF THE LOAD TRANSFERRED FROM THE DOOR.
2. EACH VERTICAL JAMBS RECEIVES MAXIMUM DESIGN LOADS OF: +252.2 LBS/FT & -285.3 LBS/FT
3. DOOR AND HARDWARE WILL BE DESIGNED, MANUFACTURED AND INSTALLED WITH STANDARDS AS SET FORTH BY DASMA.
4. DOOR SECTIONS SHALL BE 24 GA. (.022) MIN. EXTERIOR SKIN ROLLED FORMED, W/ BAKED ON POLYESTER FINISH
5. DOORS UP TO 24'0" HIGH USE (1) 5.5" 18GA R-TRUSS PER SECTION AND (1) 3" 20GA STRUT ON BOTTOM SECTION
6. SUPPORTING STRUCTURAL ELEMENTS SHALL BE DESIGNED BY A REGISTERED PROFESSIONAL ENGINEER FOR WIND LOADS INDICATED ON THIS DRAWING IN ADDITION TO OTHER LOADINGS.

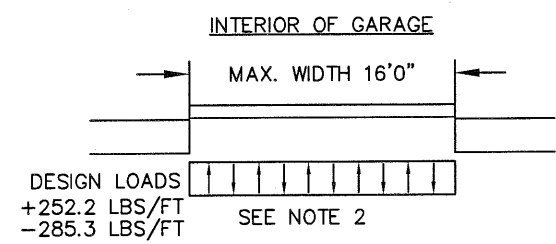

DESIGN LOADS  
+252.2 LBS/FT  
-285.3 LBS/FT  
SEE NOTE 2

REV	DESCRIPTION OF REVISIONS	DATE	BY

MAX SIZE  
16'2 x 24'

DESIGN LOADS  
+31.2 PSF  
-35.3 PSF

TEST LOADS  
+46.8 PSF  
-53.0 PSF

LARGE MISSILE IMPACT RESISTANCE

Thomas L. Shelmerdine, PE (TX PE #85829)  
Structural Solutions, PA (TX Firm #F-004063)

STATE OF TEXAS  
THOMAS L. SHELMERDINE  
85829  
LICENSED PROFESSIONAL ENGINEER

TX

5921-G.W. Friendly Ave., Greensboro, NC 27410

**Amarr**  
ENTREMATIc

**MODEL 1000 AMARR 2432**

SIZE	DRAWN BY	DRD	DATE	11/18/16	DRAWING NUMBER
B	CHECKED BY	RLR	DATE	12/05/16	IBC-1016-150-26-1

ENTREMATIc  
165 CARRIAGE COURT WINSTON-SALEM, N.C. 27105

SHEET 3 OF 4

TABLE 1

DOOR HEIGHT	TRACK ATTACHMENT																						
	A	B	C	D	E	F	G	H	I	J	K	L	M	N	O	P	Q	R	S	T	U	V	W
7' 0"	3.5"	10.0"	22.0"	34"	46"	58"																	
7' 6"	3.5"	10.0"	22.0"	34"	46"	58"	70"																
8' 0"	3.5"	10.0"	22.0"	34"	46"	58"	70"																
8' 6"	3.5"	10.0"	22.0"	34"	46"	58"	70"	82"															
9' 0"	3.5"	10.0"	22.0"	34"	46"	58"	70"	82"															
9' 6"	3.5"	10.0"	22.0"	34"	46"	58"	70"	82"	94"														
10' 0"	3.5"	10.0"	22.0"	34"	46"	58"	70"	82"	94"														
11' 0"	3.5"	10.0"	22.0"	34"	46"	58"	70"	82"	94"	106"													
12' 0"	3.5"	10.0"	22.0"	34"	46"	58"	70"	82"	94"	106"	118"												
13' 0"	3.5"	10.0"	22.0"	34"	46"	58"	70"	82"	94"	106"	118"	130"											
14' 0"	3.5"	10.0"	22.0"	34"	46"	58"	70"	82"	94"	106"	118"	130"	142"										
15' 0"	3.5"	10.0"	22.0"	34"	46"	58"	70"	82"	94"	106"	118"	130"	142"	154"									
16' 0"	3.5"	10.0"	22.0"	34"	46"	58"	70"	82"	94"	106"	118"	130"	142"	154"	166"								
17' 0"	3.5"	10.0"	22.0"	34"	46"	58"	70"	82"	94"	106"	118"	130"	142"	154"	166"	178"							
18' 0"	3.5"	10.0"	22.0"	34"	46"	58"	70"	82"	94"	106"	118"	130"	142"	154"	166"	178"	190"						
19' 0"	3.5"	10.0"	22.0"	34"	46"	58"	70"	82"	94"	106"	118"	130"	142"	154"	166"	178"	190"	202"					
20' 0"	3.5"	10.0"	22.0"	34"	46"	58"	70"	82"	94"	106"	118"	130"	142"	154"	166"	178"	190"	202"	214"				
21' 0"	3.5"	10.0"	22.0"	34"	46"	58"	70"	82"	94"	106"	118"	130"	142"	154"	166"	178"	190"	202"	214"	226"			
22' 0"	3.5"	10.0"	22.0"	34"	46"	58"	70"	82"	94"	106"	118"	130"	142"	154"	166"	178"	190"	202"	214"	226"	238"		
23' 0"	3.5"	10.0"	22.0"	34"	46"	58"	70"	82"	94"	106"	118"	130"	142"	154"	166"	178"	190"	202"	214"	226"	238"	250"	
24' 0"	3.5"	10.0"	22.0"	34"	46"	58"	70"	82"	94"	106"	118"	130"	142"	154"	166"	178"	190"	202"	214"	226"	238"	250"	262"

ALL TRACK ATTACHMENTS +/- 2" ALLOWED USING SYP OR SPF NO.2 OR BETTER ONLY

TABLE 2

Section Width (ft)	Center Stile Locations (From Left Edge)		
	1st (in)	2nd (in)	3rd (in)
9' 4"	36"	76"	-
9' 6"	37"	77"	-
9' 8"	38"	78"	-
9' 10"	39"	79"	-
10' 0"	40"	80"	-
10' 2"	41"	81"	-
10' 4"	42"	82"	-
10' 6"	43"	83"	-
10' 8"	44"	84"	-
10' 10"	45"	85"	-
11' 0"	46"	86"	-
11' 2"	47"	87"	-
11' 4"	48"	88"	-
11' 6"	49"	89"	-
11' 8"	50"	90"	-
11' 10"	51"	91"	-
12' 0"	48"	96"	-
12' 2"	49"	97"	-
13' 0"	36"	78"	120"
13' 2"	37"	79"	121"
13' 4"	38"	80"	122"
13' 6"	39"	81"	123"
13' 8"	40"	82"	124"
13' 10"	41"	83"	125"
14' 0"	42"	84"	126"
14' 2"	43"	85"	127"
14' 4"	44"	86"	128"
14' 6"	45"	87"	129"
14' 8"	46"	88"	130"
14' 10"	47"	89"	131"
14' 0"	48"	90"	132"
15' 2"	49"	91"	133"
15' 4"	50"	92"	134"
15' 6"	51"	93"	135"
15' 8"	52"	94"	136"
15' 10"	53"	95"	137"
16' 0"	48"	96"	144"
16' 2"	49"	97"	145"

\*CONTACT ENGINEERING FOR SIZES 12'4"-12'10"

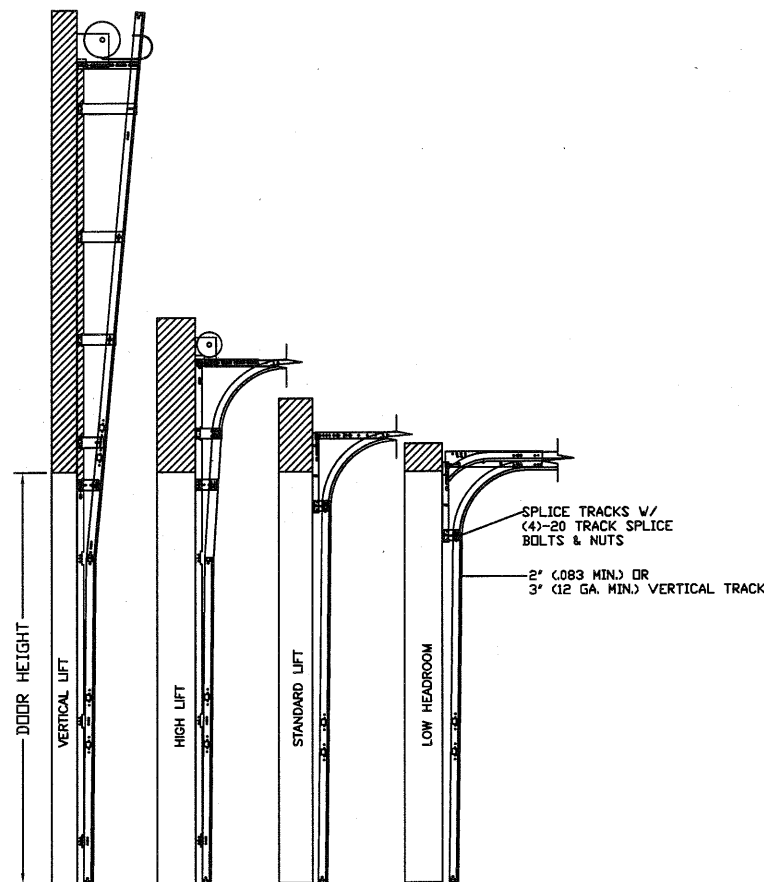

AVAILABLE TRACK CONFIGURATIONS N.T.S.

REV	DESCRIPTION OF REVISIONS	DATE	BY
	MAX SIZE 16'2" x 24'  DESIGN LOADS +31.2 PSF -35.3 PSF  TEST LOADS +46.8 PSF -53.0 PSF  LARGE MISSILE IMPACT RESISTANCE	Thomas L. Shelmerdine, PE (TX PE #85829) Structural Solutions, PA (TX Firm #F-004063)	
		TX	5921-G W. Friendly Ave., Greensboro, NC 27410
	<b>MODEL 1000 AMARR 2432</b>	DATE 11/18/16	DRAWING NUMBER
	SIZE B DRAWN BY DRD CHECKED BY RLR	DATE 12/05/16	IBC-1016-150-26-1
	ENTREMATIC 165 CARRIAGE COURT WINSTON-SALEM, NC. 27105	SHEET 4 OF 4	SHEET 4 OF 4