

TYPICAL TOP FIXTURES
N.T.S. ①

ADJUSTABLE ROLLER CARRIER ATTACHED W/ (2) 5/16\" x 3/4\" BOLT & NUT PER BRACKET

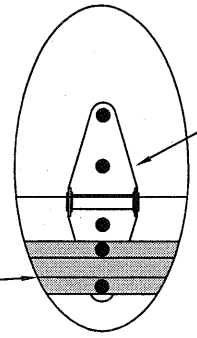

TYPICAL CENTER HINGE
N.T.S. ②

2\" 20GA. STRUT ATTACHED W/ (2) 1/4\" x 1\" SCREWS AT EACH CENTER STILE

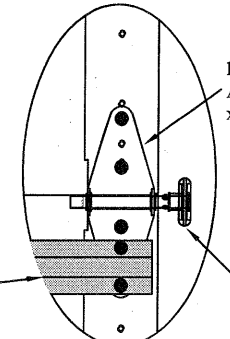

TYPICAL END HINGE
N.T.S. ③

2\" 20GA. STRUT ATTACHED W/ (2) 1/4\" x 1\" SCREWS AT EACH END STILE

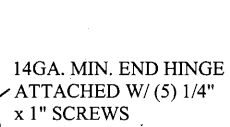

TYPICAL BOTTOM BRACKET
N.T.S. ④

BOTTOM BRACKET 11 GA. (MIN.) ATTACHED W/ (7) 1/4\" x 1\" HEX HEAD SCREWS

2\" 10 BALL STEEL LONG STEM ROLLERS (MIN.) W/ 7/16\" RETAINER USED FOR NON-THREADED SHAFTS

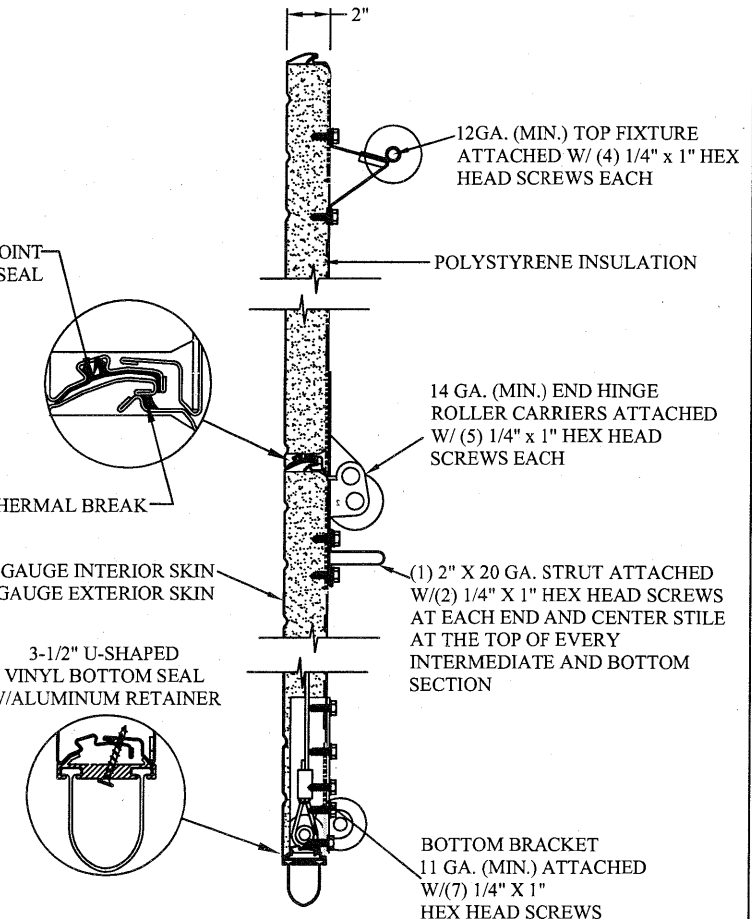

SECTION A-A (SIDE VIEW)
N.T.S.

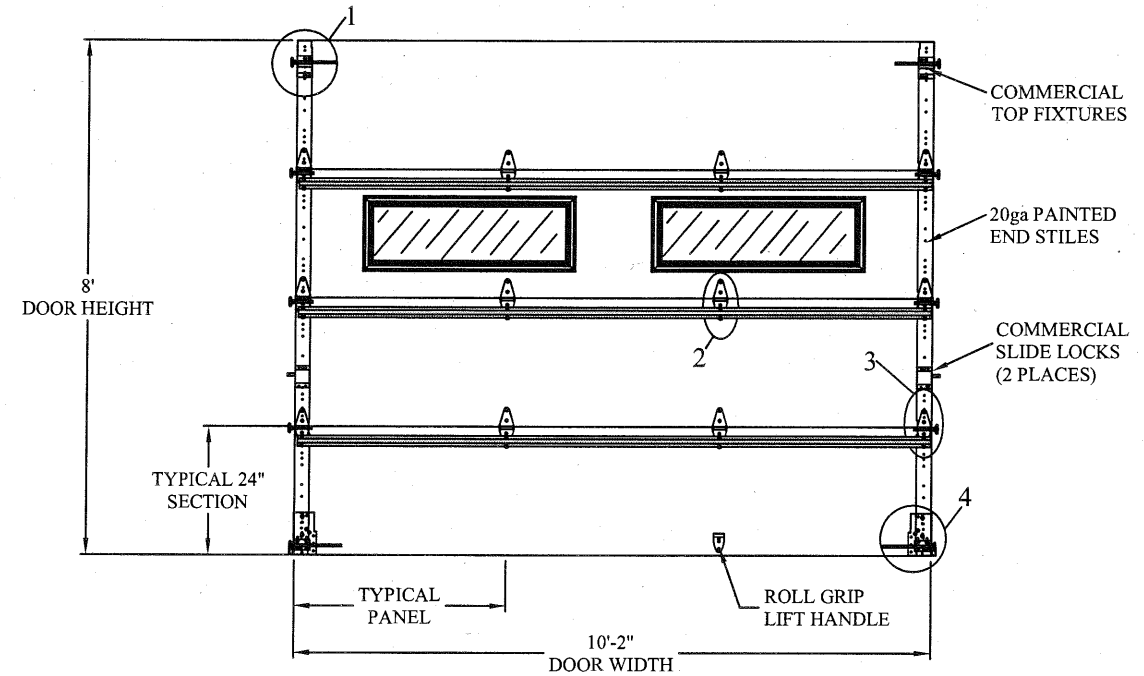

DOOR INTERIOR ELEVATION
N.T.S.

LARGE MISSILE IMPACT RESISTANT

THE METHOD OF TESTING WAS IN SUBSTANTIAL CONFORMANCE WITH THE PROCEDURES DESCRIBED IN ASTM E1886, E1996, F588, AND DASMA 108, 115. THE PRESSURES SHOWN ON THE DRAWINGS WERE CALCULATED USING ASCE 7-98/02/05 WITH THE FOLLOWING PARAMETERS (5 FEET OF DOOR WIDTH IN END ZONE, ROOF SLOPE 10° OR LESS, AND I=1.0):

WIND SPEED (MPH)	130	118	112	107	103
EXPOSURE LEVEL	B	C	C	D	D
MEAN ROOF HEIGHT	30'	15'	25'	15'	25'

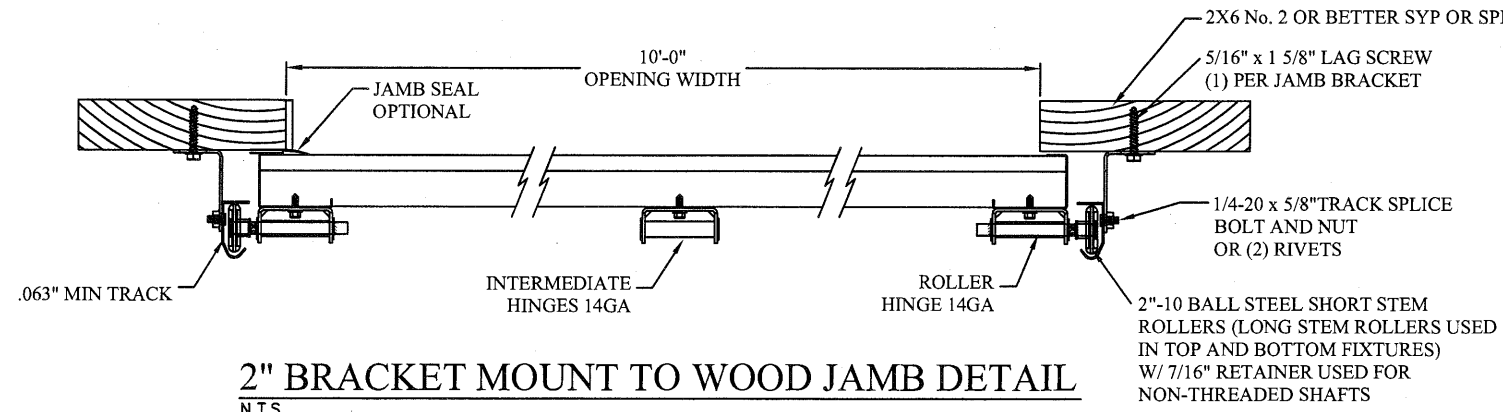

2\"/>

REV	DESCRIPTION OF REVISIONS	DATE	BY

MAX SIZE 10'2 x 24'

DESIGN LOADS +24.1 PSF -28.0 PSF

TEST LOADS +36.2 PSF -42.0 PSF

LARGE MISSILE IMPACT RESISTANCE

Thomas L. Shelmerdine, PE (TX PE #85829) Structural Solutions, PA (TX Firm #F-004063)

STATE OF TEXAS
THOMAS L. SHELMERDINE
85829
LICENSED PROFESSIONAL ENGINEER
TX

Amarr
ENTREMATICS

MODEL 1000 AMARR 2432

SIZE	DRAWN BY RLR	DATE 3/8/17	DRAWING NUMBER
B	CHECKED BY RLR	DATE 3/8/17	IBC-1010-130-11-1

ENTREMATICS
165 CARRIAGE COURT WINSTON-SALEM, N.C. 27105

SHEET 1 OF 4

5921-G.W. Friendly Ave., Greensboro, NC 27410

TRACK CONNECTION DIRECTLY TO STRUCTURE OPTIONS

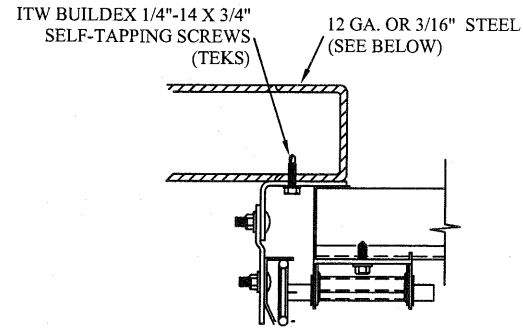

CLIP STYLE REVERSE ANGLE MOUNT SHOWN
BRACKET, CONTINUOUS AND TAPERED ANGLE
MOUNT AVAILABLE

12 GA. STEEL FRAMING
232 LBS./SCREW ALLOWABLE LOAD - 6" FROM ENDS
AND 22" O.C.
REFER TO NOTES: 1, 2 AND 5

3/16" STEEL FRAMING
569 LBS./SCREW ALLOWABLE LOAD - 6" FROM ENDS
AND 24" O.C.
REFER TO NOTES: 1, 2 AND 5

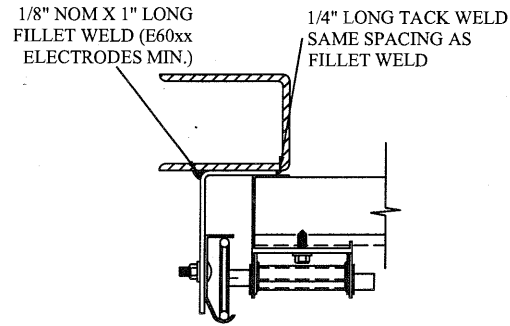

REVERSE ANGLE MOUNT SHOWN
BRACKET, CONTINUOUS AND TAPERED
ANGLE MOUNT AVAILABLE

STEEL FRAMING 12GA OR BETTER
1590 LBS./IN. ALLOWABLE LOAD - 6"
FROM ENDS AND 24" O.C.
REFER TO NOTES: 1, 2, 5, 6, 7, 8 AND 9

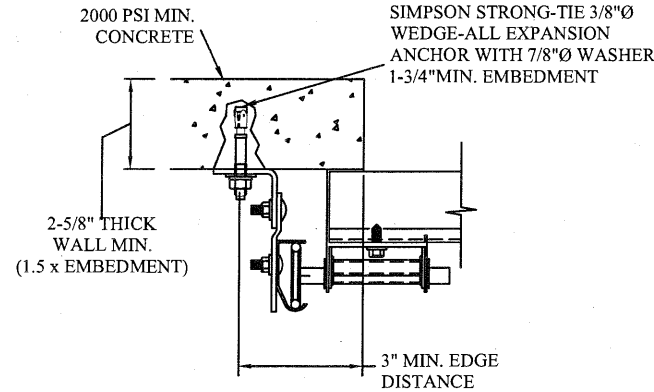

CLIP STYLE CONTINUOUS ANGLE MOUNT SHOWN
BRACKET, REVERSE AND TAPERED ANGLE MOUNT
AVAILABLE

2000 PSI CONCRETE OR GREATER
351 LBS./EXPANSION ANCHOR ALLOWABLE LOAD - 6"
FROM ENDS AND 24" O.C.
REFER TO NOTES: 1, 2, 3, 4 AND 5

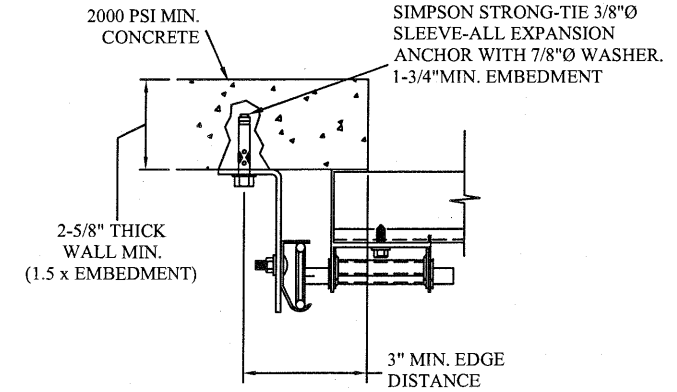

CONTINUOUS ANGLE MOUNT SHOWN
BRACKET, CONTINUOUS AND TAPERED ANGLE
MOUNT AVAILABLE

2000 PSI CONCRETE OR GREATER
336 LBS./EXPANSION ANCHOR ALLOWABLE LOAD - 6"
FROM ENDS AND 24" O.C.
REFER TO NOTES: 1, 2, 3, 4 AND 5

WOOD JAMB ATTACHMENT TO STRUCTURE (OPTIONAL)

2 X 6 VERTICAL JAMB ATTACHMENT TO WOOD FRAME STRUCTURE

5/16" X 3" LAG SCREWS STARTING 6" FROM ENDS
THEN 24" O.C. (1 1/2" EMBEDMENT)

2 X 6 VERTICAL JAMB ATTACHMENT TO 2,000 PSI CONCRETE

HILTI KWIK BOLT 3/8" X 4" STARTING 6" FROM ENDS
THEN 24" O.C. (2 1/2" EMBEDMENT)

HILTI SLEEVE ANCHOR 3/8" X 2-3/4" STARTING 6" FROM ENDS
THEN 24" O.C. (1 1/4" EMBEDMENT)

ITW/RAMSET REDHEAD (TRU-BOLT) 3/8" X 4" STARTING 6" FROM ENDS
THEN 24" O.C. (2 1/2" EMBEDMENT)

2 X 6 VERTICAL JAMB ATTACHMENT TO HOLLOW C-90 BLOCK

SIMPSON 1/4" X 3" TITEN SCREWS STARTING 6" FROM ENDS,
USE PAIRS OF FASTENERS (3" APART)
AT 24" O.C. (1 1/2" EMBEDMENT)

HILTI 1/4" X 2-3/4" KWIK-CON II+ SCREWS STARTING 6" FROM ENDS,
USE PAIRS OF FASTENERS (3" APART) AT 24" O.C. (1 1/4" EMBEDMENT)

2 X 6 VERTICAL JAMB ATTACHMENT TO GROUTED C-90 BLOCK (2000 PSI GROUT)

HILTI SLEEVE ANCHOR 3/8" X 2-3/4" STARTING 6" FROM ENDS
THEN 24" O.C. (1 1/4" EMBEDMENT)

(OR, USE FASTENERS FOR HOLLOW C-90 BLOCK)

*LAGS AND BOLTS CAN BE COUNTERSUNK TO PROVIDE A FLUSH MOUNTING SURFACE.

*PREPARATION OF WOOD JAMBS BY OTHERS

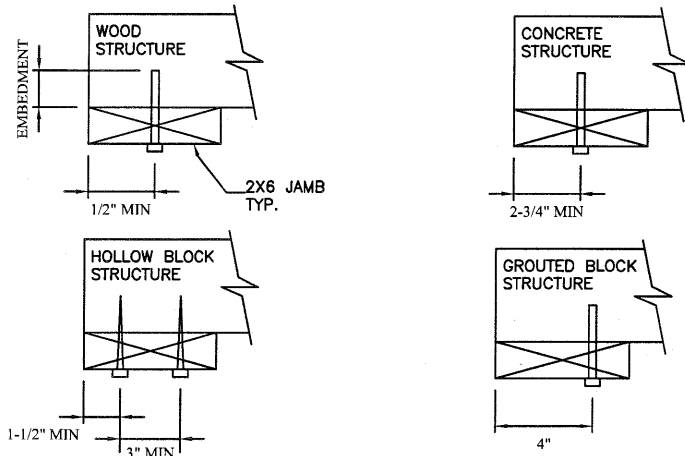

NOTES:

1. ANCHORS TO BE EVENLY SPACED BETWEEN THE HEADER AND FLOOR.
2. FIRST (BOTTOM) ANCHOR STARTING AT NO MORE THAN HALF OF THE MAXIMUM ON-CENTER DISTANCE. HIGHEST ANCHOR INSTALLED AT LEAST AS HIGH AS THE DOOR OPENING.
3. MIN. EGDE DISTANCE OF 3" REQUIRED.
4. USE WASHERS PROVIDED BY THE ANCHOR MANUFACTURER.
5. SUPPORTING STRUCTURAL ELEMENTS SHALL BE DESIGNED BY A REGISTERED PROFESSIONAL ENGINEER FOR WIND LOADS IN ADDITION TO OTHER LOADS.
6. MOST GARAGE DOOR TRACK IS GALVANIZED STEEL. USE ALL NECESSARY PRECAUTIONS WHEN WELDING GALVANIZED STEEL.
7. ALL WELDS SHOULD BE PERFORMED BY A CERTIFIED WELDER OR INSPECTED BY A CERTIFIED WELDING INSPECTOR TO VERIFY THE INTEGRITY OF THE WELD.
8. FILLET WELDS TO HAVE A STRAIGHT OR CONVEX FACE SURFACE.
9. TACK WELD TOE OF ANGLE AT SAME SPACING TO PREVENT ROTATION OF TRACK ANGLE.

TRACK CONNECTION TO WOOD JAMB OPTIONS

FOR LAG SCREWS & BRACKET SPACING SEE PAGE 4 FOR TRACK CONFIGURATION DETAIL

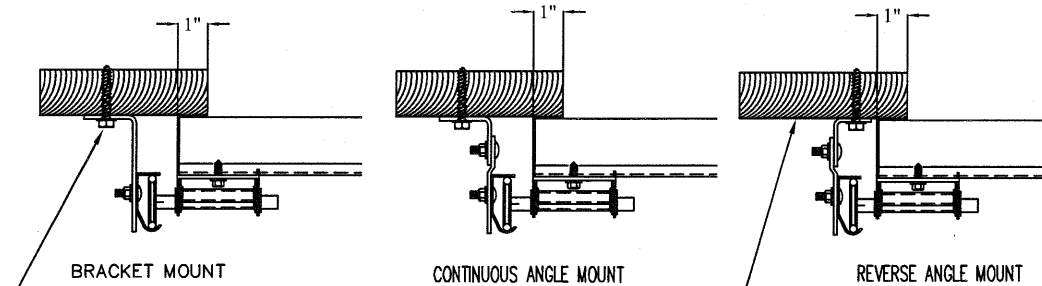

5/16" x 1 5/8" LAG SCREW (1) PER
JAMB BRACKET (1-1/2" EMBEDMENT
MINIMUM) (TYP.)

2x6 WOOD JAMB SYP OR SPF
(NO.2) OR BETTER (TYP.)

REV	DESCRIPTION OF REVISIONS	DATE	BY														
	<p>MAX SIZE 10'2 x 24'</p> <p>DESIGN LOADS +24.1 PSF -28.0 PSF</p> <p>TEST LOADS +36.2 PSF -42.0 PSF</p> <p>LARGE MISSILE IMPACT RESISTANCE</p>																
	<p>Thomas L. Shelmerdine, PE (TX PE #85829) Structural Solutions, PA (TX Firm #F-004063)</p> <div style="text-align: center;"> <p>TX</p> </div>																
	<p>MODEL 1000 AMARR 2432</p>																
	<table border="1" style="width: 100%; border-collapse: collapse;"> <tr> <td style="width: 5%;">SIZE</td> <td style="width: 15%;">DRAWN BY</td> <td style="width: 10%;">RLR</td> <td style="width: 10%;">DATE</td> <td style="width: 10%;">3/8/17</td> <td style="width: 10%;">DRAWING NUMBER</td> <td style="width: 10%;">IBC-1010-130-11-1</td> </tr> <tr> <td>B</td> <td>CHECKED BY</td> <td>RLR</td> <td>DATE</td> <td>3/8/17</td> <td colspan="2"> </td> </tr> </table>	SIZE	DRAWN BY	RLR	DATE	3/8/17	DRAWING NUMBER	IBC-1010-130-11-1	B	CHECKED BY	RLR	DATE	3/8/17				
SIZE	DRAWN BY	RLR	DATE	3/8/17	DRAWING NUMBER	IBC-1010-130-11-1											
B	CHECKED BY	RLR	DATE	3/8/17													
	<p>ENTREMATiC 165 CARRIAGE COURT WINSTON-SALEM, N.C. 27105</p>																

5921-G.W. Friendly Ave., Greensboro, NC 27410

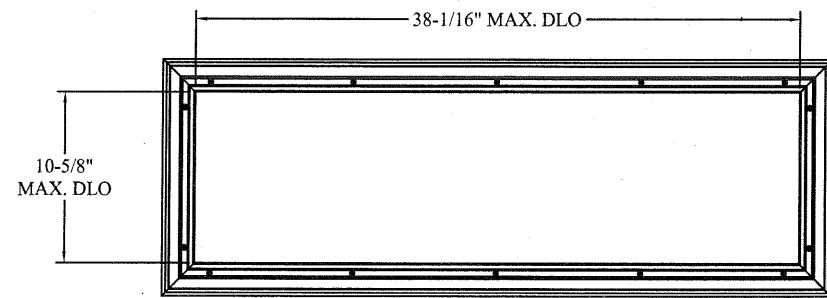

LONG PANEL IMPACT GLAZING FASTENER DETAIL
N.T.S.

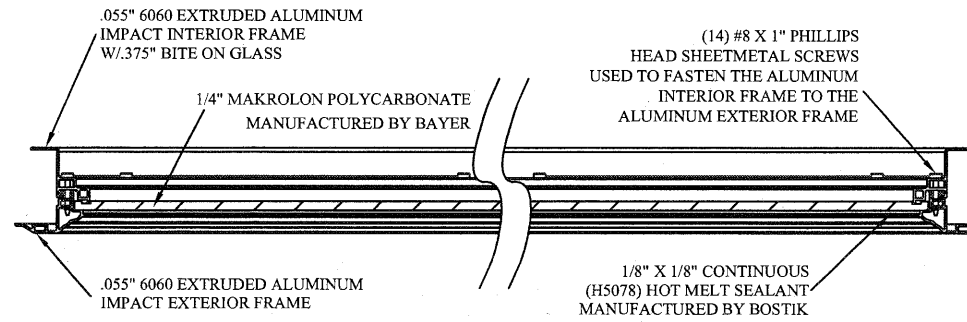

SECTION B-B IMPACT WINDOW DETAIL
N.T.S.

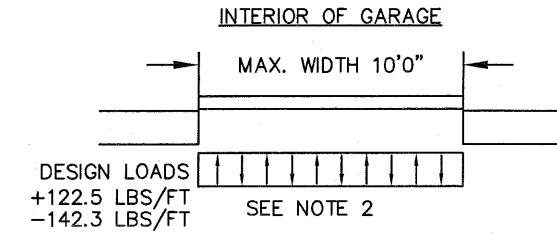

SPECIFICATIONS AND NOTES

1. ALL THE LOAD FROM THE DOOR IS TRANSFERRED TO THE VERTICAL TRACK, FROM THE TRACK THE LOAD IS TRANSFERRED TO THE VERTICAL JAMBS. THE HORIZONTAL JAMB OR HEADER RECEIVES NO PORTION OF THE LOAD TRANSFERRED FROM THE DOOR.
2. EACH VERTICAL JAMBS RECEIVES MAXIMUM DESIGN LOADS OF: +122.5 LBS/FT & -142.3 LBS/FT
3. DOOR AND HARDWARE WILL BE DESIGNED, MANUFACTURED AND INSTALLED WITH STANDARDS AS SET FORTH BY DASMA.
4. DOOR SECTIONS SHALL BE 24 GA. (.021) MIN. EXTERIOR SKIN ROLLED FORMED, W/ BAKED ON POLYESTER FINISH
5. DOORS UP TO 24'0" HIGH HAVE (1) 2" 20GA STRUT PER INTERMEDIATE AND BOTTOM SECTION
6. SUPPORTING STRUCTURAL ELEMENTS SHALL BE DESIGNED BY A REGISTERED PROFESSIONAL ENGINEER FOR WIND LOADS INDICATED ON THIS DRAWING IN ADDITION TO OTHER LOADINGS.

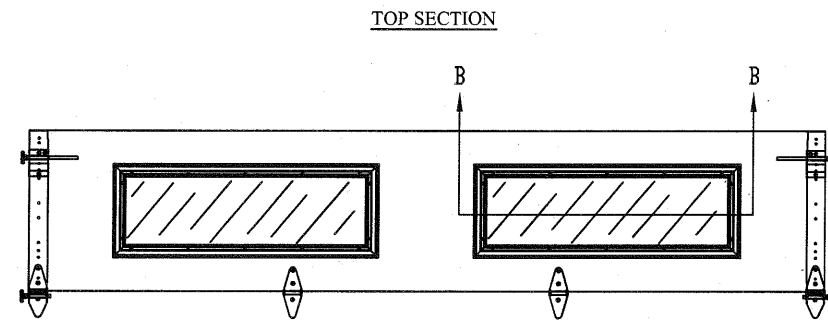

OPTIONAL GLAZED SECTION W/LONG PANEL IMPACT WINDOWS
N.T.S.

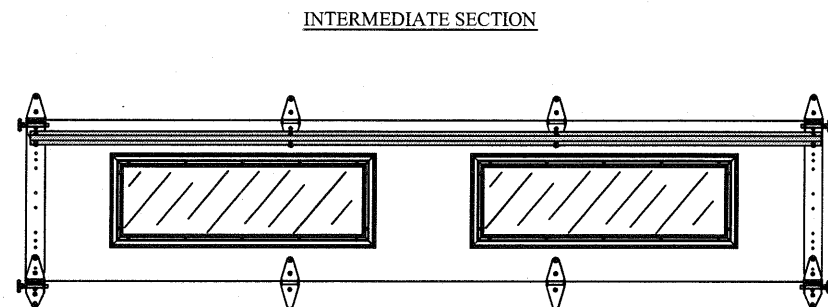

OPTIONAL GLAZED SECTION W/LONG PANEL IMPACT WINDOWS
N.T.S.

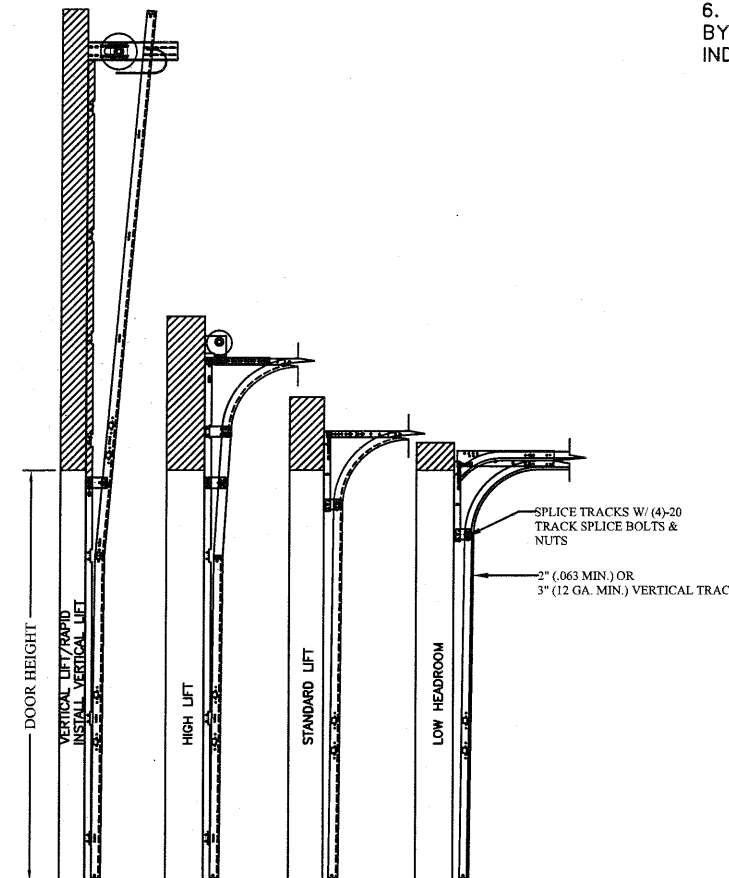

AVAILABLE TRACK CONFIGURATIONS
N.T.S.

REV	DESCRIPTION OF REVISIONS	DATE	BY
	MAX SIZE 10'2 x 24'		
	DESIGN LOADS +24.1 PSF -28.0 PSF		
	TEST LOADS +36.2 PSF -42.0 PSF		
	LARGE MISSILE IMPACT RESISTANCE		
Thomas L. Shelmerdine, PE (TX PE #85829) Structural Solutions, PA (TX Firm #F-004063)			
		5921-G W. Friendly Ave., Greensboro, NC 27410	
MODEL 1000 AMARR 2432			
SIZE	DRAWN BY RLR	DATE 3/8/17	DRAWING NUMBER
B	CHECKED BY RLR	DATE 3/8/17	IBC-1010-130-11-1
ENTREMATiC 165 CARRIAGE COURT WINSTON-SALEM, N.C. 27105			SHEET 3 OF 4

TABLE 1

Section Width (ft)	Center Stile Locations	
	1st (in)	2nd (in)
6' 0"	36"	-
6' 2"	37"	-
6' 4"	38"	-
6' 6"	39"	-
6' 8"	40"	-
9' 4"	36"	76"
9' 6"	37"	77"
9' 8"	38"	78"
9' 10"	39"	79"
10' 0"	40"	80"
10' 2"	41"	81"

* CONTACT ENGINEERING FOR SIZES 6'10" THROUGH 9'2"

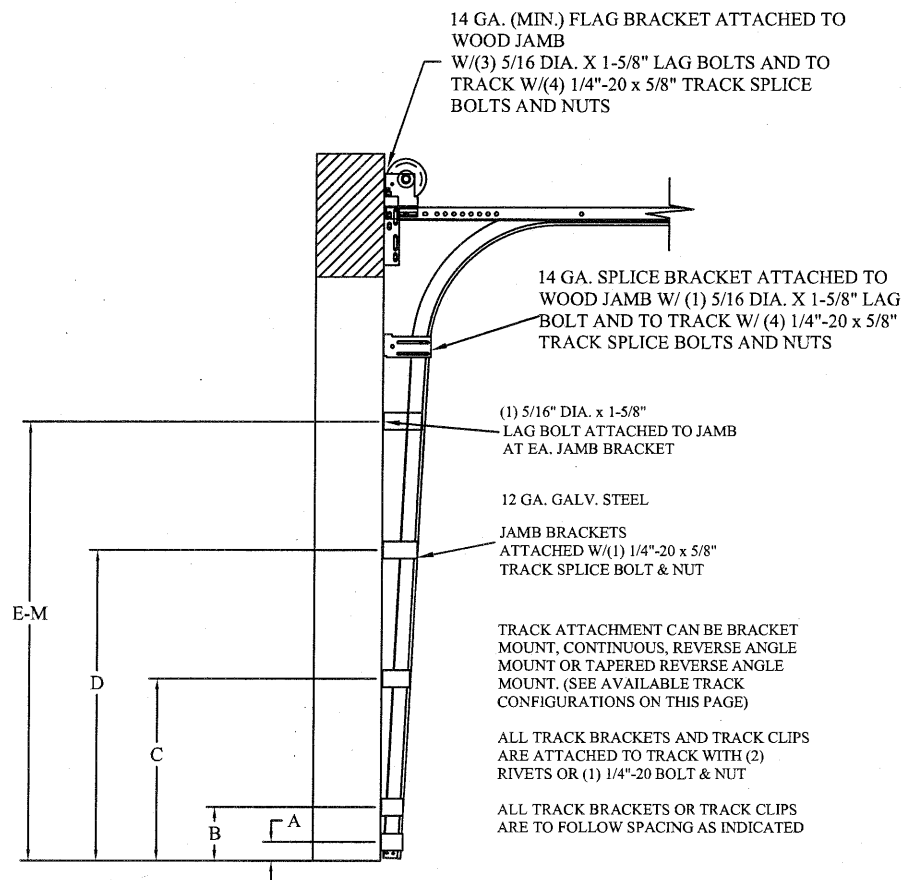

TRACK CONFIGURATION FOR UP TO 24' TALL DOORS
SEE TABLE 2

TABLE 2

DOOR HEIGHT	TRACK ATTACHMENT													TYPICAL SPLICE
	A	B	C	D	E	F	G	H	I	J	K	L	M	
7' 0"	3.5"	10.0"	34"	58"										76"
7' 6"	3.5"	10.0"	34"	58"										82"
8' 0"	3.5"	10.0"	34"	58"	82"									88"
8' 6"	3.5"	10.0"	34"	58"	82"									94"
9' 0"	3.5"	10.0"	34"	58"	82"									100"
9' 6"	3.5"	10.0"	34"	58"	82"									106"
10' 0"	3.5"	10.0"	34"	58"	82"	106"								112"
11' 0"	3.5"	10.0"	34"	58"	82"	106"								124"
12' 0"	3.5"	10.0"	34"	58"	82"	106"	130"							136"
13' 0"	3.5"	10.0"	34"	58"	82"	106"	130"							148"
14' 0"	3.5"	10.0"	34"	58"	82"	106"	130"	154"						160"
15' 0"	3.5"	10.0"	34"	58"	82"	106"	130"	154"						172"
16' 0"	3.5"	10.0"	34"	58"	82"	106"	130"	154"	178"					184"
17' 0"	3.5"	10.0"	34"	58"	82"	106"	130"	154"	178"					196"
18' 0"	3.5"	10.0"	34"	58"	82"	106"	130"	154"	178"	202"				208"
19' 0"	3.5"	10.0"	34"	58"	82"	106"	130"	154"	178"	202"				220"
20' 0"	3.5"	10.0"	34"	58"	82"	106"	130"	154"	178"	202"	226"			232"
21' 0"	3.5"	10.0"	34"	58"	82"	106"	130"	154"	178"	202"	226"			244"
22' 0"	3.5"	10.0"	34"	58"	82"	106"	130"	154"	178"	202"	226"	250"		256"
23' 0"	3.5"	10.0"	34"	58"	82"	106"	130"	154"	178"	202"	226"	250"		268"
24' 0"	3.5"	10.0"	34"	58"	82"	106"	130"	154"	178"	202"	226"	250"	274"	280"

ALL TRACK ATTACHMENTS +/- 2" ALLOWED USING SYP OR SPF NO.2 OR BETTER ONLY

REV	DESCRIPTION OF REVISIONS	DATE	BY

MAX SIZE
10'2 x 24'

DESIGN LOADS
+24.1 PSF
-28.0 PSF

TEST LOADS
+36.2 PSF
-42.0 PSF

LARGE MISSILE IMPACT
RESISTANCE

Thomas L. Shelmerdine, PE (TX PE #85829)
Structural Solutions, PA (TX Firm #004063)

TX

5921-G W. Friendly Ave., Greensboro, NC 27410

MODEL 1000 AMARR 2432

SIZE	DRAWN BY	RLR	DATE	3/8/17	DRAWING NUMBER
B	CHECKED BY	RLR	DATE	3/8/17	IBC-1010-130-11-1
ENTREMATIC					SHEET 4 OF 4

165 CARRIAGE COURT WINSTON-SALEM, N.C. 27105