

TYPICAL TOP FIXTURES
N.T.S. 1

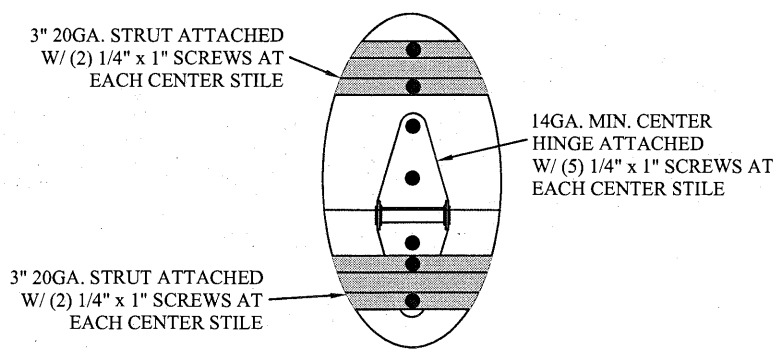

TYPICAL CENTER HINGE
N.T.S. 2

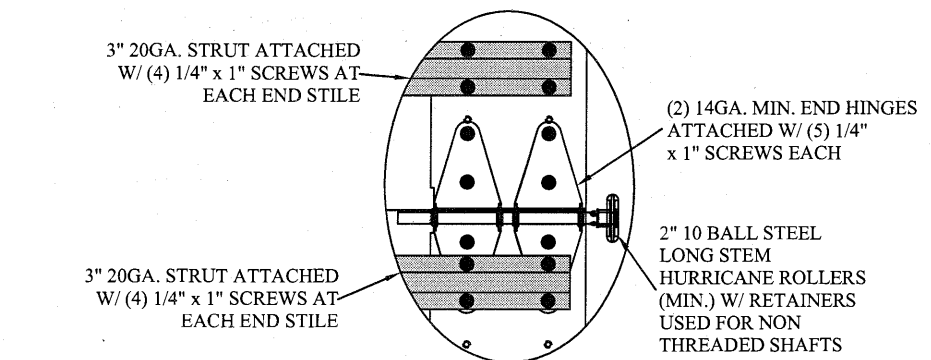

TYPICAL END HINGE
N.T.S. 3

LARGE MISSILE IMPACT
RESISTANT

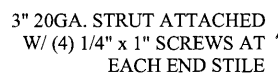

TYPICAL BOTTOM BRACKET
N.T.S. 4

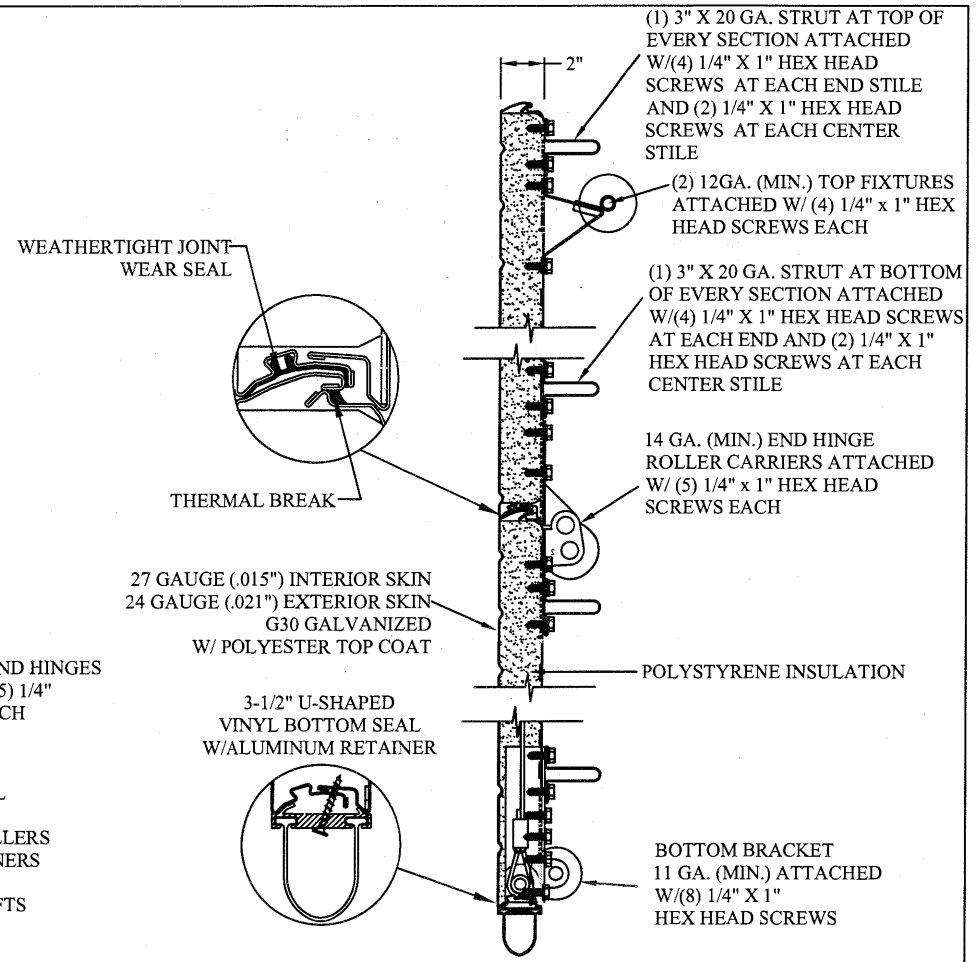

SECTION A-A (SIDE VIEW)
N.T.S.

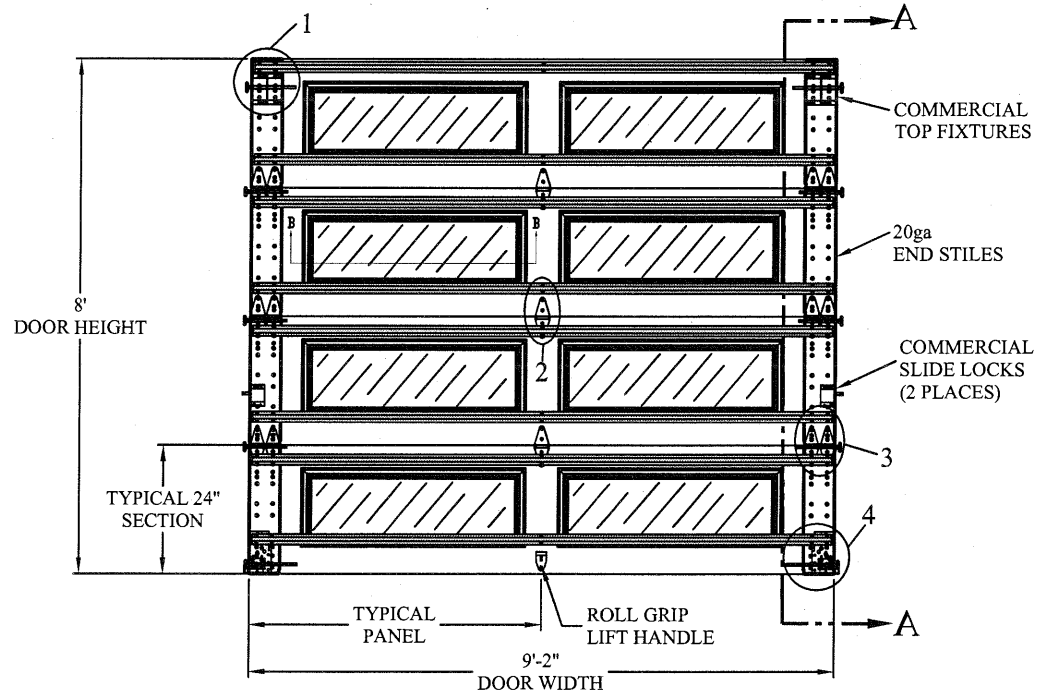

DOOR INTERIOR ELEVATION
N.T.S.

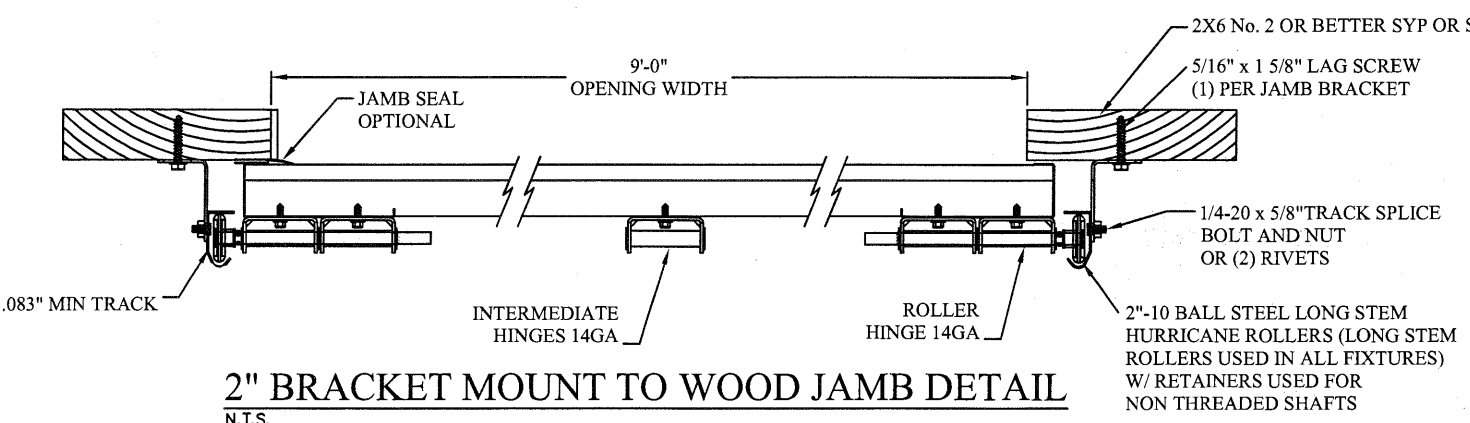

2\"/>

THE METHOD OF TESTING WAS IN SUBSTANTIAL CONFORMANCE WITH THE PROCEDURE DESCRIBED IN DASMA 108-05 & 115-05, AND ASTM E330-02, E1886-05, E1996-09, & F588-07. THE PRESSURES SHOWN ON THE DRAWINGS WERE CALCULATED USING ASCE 7-05 WITH THE FOLLOWING PARAMETERS (5 FEET OF DOOR WIDTH IN THE END ZONE, ROOF LESS THAN OR EQUAL TO 10 DEGREES SLOPE, I=1.0).

WIND SPEED (MPH)	196	178	169	161	155
EXPOSURE LEVEL	B	C	C	D	D
MEAN ROOF HEIGHT	30'	15'	25'	15'	25'

REV	DESCRIPTION OF REVISIONS	DATE	BY

MAX SIZE 9'2 x 24'

DESIGN LOADS
+55.1 PSF
-64.5 PSF

TEST LOADS
+82.7 PSF
-96.8 PSF

LARGE MISSILE IMPACT RESISTANCE

Thomas L. Shelmerdine, PE (TX PE #85829)
Structural Solutions, PA (TX Firm #F-004063)

TX

Amarr
ENTREMATIC

MODEL 1000 AMARR 2432

SIZE	DRAWN BY	RLR	DATE	6/5/17	DRAWING NUMBER
B	CHECKED BY	RLR	DATE	6/5/17	IBC-1009-195-15-F

ENTREMATIC
165 CARRIAGE COURT WINSTON-SALEM, N.C. 27105

SHEET 1 OF 3

5921-G W. Friendly Ave., Greensboro, NC 27410

TRACK CONNECTION DIRECTLY TO STRUCTURE OPTIONS

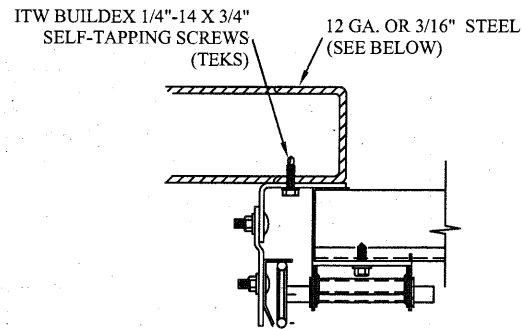

CLIP STYLE REVERSE ANGLE MOUNT SHOWN
BRACKET, CONTINUOUS AND TAPERED ANGLE
MOUNT AVAILABLE

12 GA. STEEL FRAMING
232 LBS./SCREW ALLOWABLE LOAD - 6" FROM ENDS
AND 10" O.C.
REFER TO NOTES: 1, 2 AND 5

3/16" STEEL FRAMING
569 LBS./SCREW ALLOWABLE LOAD - 6" FROM ENDS
AND 24" O.C.
REFER TO NOTES: 1, 2 AND 5

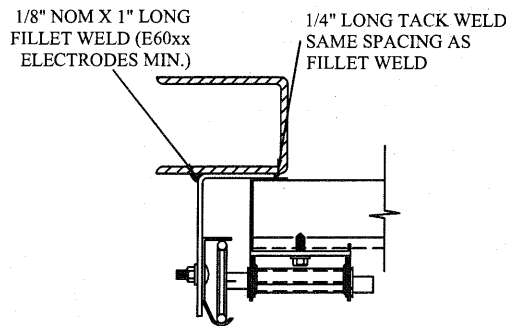

REVERSE ANGLE MOUNT SHOWN
BRACKET, CONTINUOUS AND TAPERED
ANGLE MOUNT AVAILABLE

STEEL FRAMING 12GA OR BETTER
1590 LBS./IN. ALLOWABLE LOAD - 6"
FROM ENDS AND 24" O.C.
REFER TO NOTES: 1, 2, 5, 6, 7, 8 AND 9

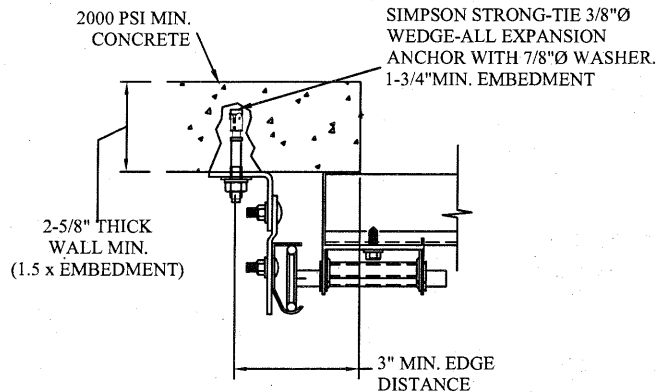

CLIP STYLE CONTINUOUS ANGLE MOUNT SHOWN
BRACKET, REVERSE AND TAPERED ANGLE MOUNT
AVAILABLE

2000 PSI CONCRETE OR GREATER
351 LBS./EXPANSION ANCHOR ALLOWABLE LOAD - 6"
FROM ENDS AND 16" O.C.
REFER TO NOTES: 1, 2, 3, 4 AND 5

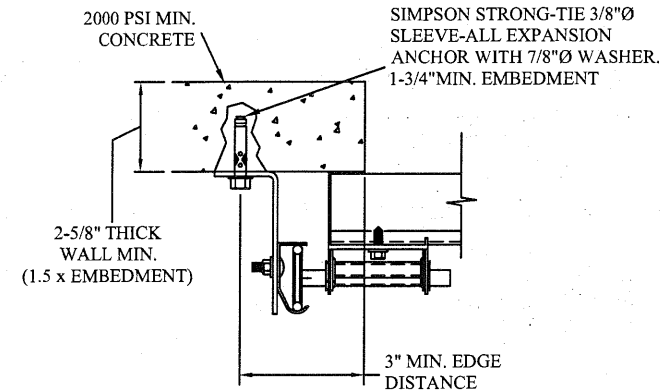

CONTINUOUS ANGLE MOUNT SHOWN
BRACKET, CONTINUOUS AND TAPERED ANGLE
MOUNT AVAILABLE

2000 PSI CONCRETE OR GREATER
336 LBS./EXPANSION ANCHOR ALLOWABLE LOAD - 6"
FROM ENDS AND 16" O.C.
REFER TO NOTES: 1, 2, 3, 4 AND 5

WOOD JAMB ATTACHMENT TO STRUCTURE (OPTIONAL)

2 X 6 VERTICAL JAMB ATTACHMENT TO WOOD FRAME STRUCTURE
5/16" X 3" LAG SCREWS STARTING 6" FROM ENDS
THEN 18" O.C. (1 1/2" EMBEDMENT)

2 X 6 VERTICAL JAMB ATTACHMENT TO 2,000 PSI CONCRETE
HILTI KWIK BOLT 3/8" X 4" STARTING 6" FROM ENDS
THEN 24" O.C. (2 1/2" EMBEDMENT)

HILTI SLEEVE ANCHOR 3/8" X 2-3/4" STARTING 6" FROM ENDS
THEN 16" O.C. (1 1/4" EMBEDMENT)

ITW/RAMSET REDHEAD (TRU-BOLT) 3/8" X 4" STARTING 6" FROM ENDS
THEN 24" O.C. (2 1/2" EMBEDMENT)

2 X 6 VERTICAL JAMB ATTACHMENT TO HOLLOW C-90 BLOCK
SIMPSON 1/4" X 3" TITEN SCREWS STARTING 6" FROM ENDS,
USE PAIRS OF FASTENERS (3" APART)
AT 8" O.C. (1 1/2" EMBEDMENT)

HILTI 1/4" X 2-3/4" KWIK-CON II+ SCREWS STARTING 6" FROM ENDS,
USE PAIRS OF FASTENERS (3" APART) AT 8" O.C. (1 1/4" EMBEDMENT)

2 X 6 VERTICAL JAMB ATTACHMENT TO GROUTED C-90 BLOCK (2000 PSI GROUT)
HILTI SLEEVE ANCHOR 3/8" X 2-3/4" STARTING 6" FROM ENDS
THEN 20" O.C. (1 1/4" EMBEDMENT)

(OR, USE FASTENERS FOR HOLLOW C-90 BLOCK)
*LAGS AND BOLTS CAN BE COUNTERSUNK TO PROVIDE A FLUSH MOUNTING SURFACE.
*PREPARATION OF WOOD JAMBS BY OTHERS

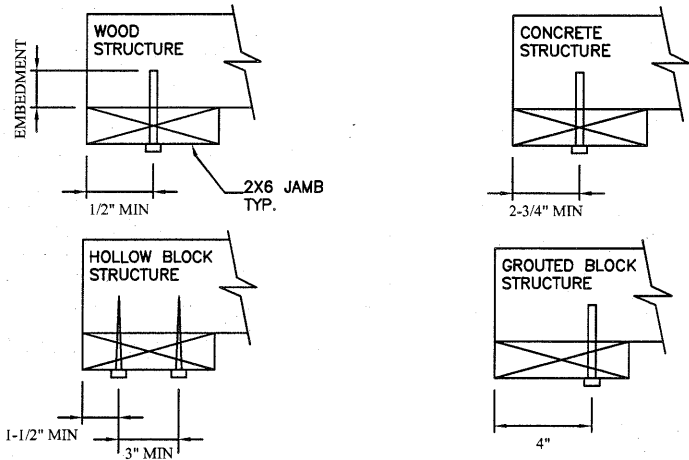

NOTES:

- ANCHORS TO BE EVENLY SPACED BETWEEN THE HEADER AND FLOOR.
- FIRST (BOTTOM) ANCHOR STARTING AT NO MORE THAN HALF OF THE MAXIMUM ON-CENTER DISTANCE. HIGHEST ANCHOR INSTALLED AT LEAST AS HIGH AS THE DOOR OPENING.
- MIN. EDGE DISTANCE OF 3" REQUIRED.
- USE WASHERS PROVIDED BY THE ANCHOR MANUFACTURER.
- SUPPORTING STRUCTURAL ELEMENTS SHALL BE DESIGNED BY A REGISTERED PROFESSIONAL ENGINEER FOR WIND LOADS IN ADDITION TO OTHER LOADS.
- MOST GARAGE DOOR TRACK IS GALVANIZED STEEL. USE ALL NECESSARY PRECAUTIONS WHEN WELDING GALVANIZED STEEL.
- ALL WELDS SHOULD BE PERFORMED BY A CERTIFIED WELDER OR INSPECTED BY A CERTIFIED WELDING INSPECTOR TO VERIFY THE INTEGRITY OF THE WELD.
- FILLET WELDS TO HAVE A STRAIGHT OR CONVEX FACE SURFACE.
- TACK WELD TOE OF ANGLE AT SAME SPACING TO PREVENT ROTATION OF TRACK ANGLE.

SPECIFICATIONS AND NOTES

- ALL THE LOAD FROM THE DOOR IS TRANSFERRED TO THE VERTICAL TRACK, FROM THE TRACK THE LOAD IS TRANSFERRED TO THE VERTICAL JAMBS. THE HORIZONTAL JAMB OR HEADER RECEIVES NO PORTION OF THE LOAD TRANSFERRED FROM THE DOOR.
- EACH VERTICAL JAMBS RECEIVES MAXIMUM DESIGN LOADS OF: +252.6 LBS/FT & -295.6 LBS/FT
- DOOR AND HARDWARE WILL BE DESIGNED, MANUFACTURED AND INSTALLED WITH STANDARDS AS SET FORTH BY DASMA.
- DOOR SECTIONS SHALL BE 24 GA. (.021) MIN. EXTERIOR SKIN ROLLED FORMED, G30 GALVANIZED W/ POLYESTER TOP COAT
- DOORS UP TO 24'0" HIGH HAVE (2) 3" 20GA STRUTS PER SECTION
- SUPPORTING STRUCTURAL ELEMENTS SHALL BE DESIGNED BY A REGISTERED PROFESSIONAL ENGINEER FOR WIND LOADS INDICATED ON THIS DRAWING IN ADDITION TO OTHER LOADINGS.

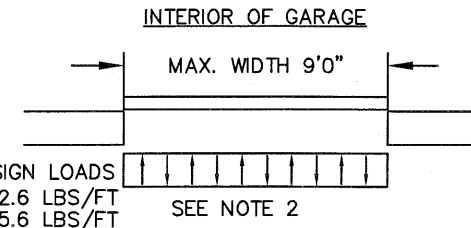

TRACK CONNECTION TO WOOD JAMB OPTIONS

FOR LAG SCREWS & BRACKET SPACING SEE PAGE 3 FOR TRACK CONFIGURATION DETAIL

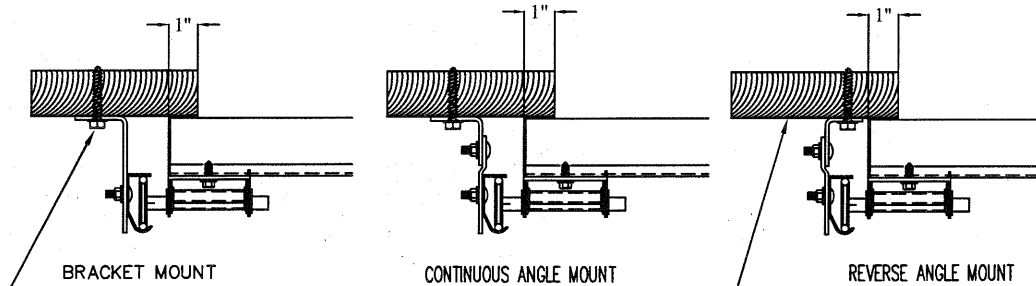

5/16" x 1 5/8" LAG SCREW (1) PER
JAMB BRACKET (1-1/2" EMBEDMENT
MINIMUM) (TYP.)

2x6 WOOD JAMB SYP OR SPF
(NO.2) OR BETTER (TYP.)

REV	DESCRIPTION OF REVISIONS	DATE	BY
	MAX SIZE 9'2 x 24' DESIGN LOADS +55.1 PSF -64.5 PSF TEST LOADS +82.7 PSF -96.8 PSF LARGE MISSILE IMPACT RESISTANCE		
	MODEL 1000 AMARR 2432		
	SIZE B DRAWN BY RDR CHECKED BY RLR	DATE 6/5/17 DATE 6/5/17	DRAWING NUMBER IBC-1009-195-15-F SHEET 2 OF 3

5921-G W. Friendly Ave., Greensboro, NC 27410

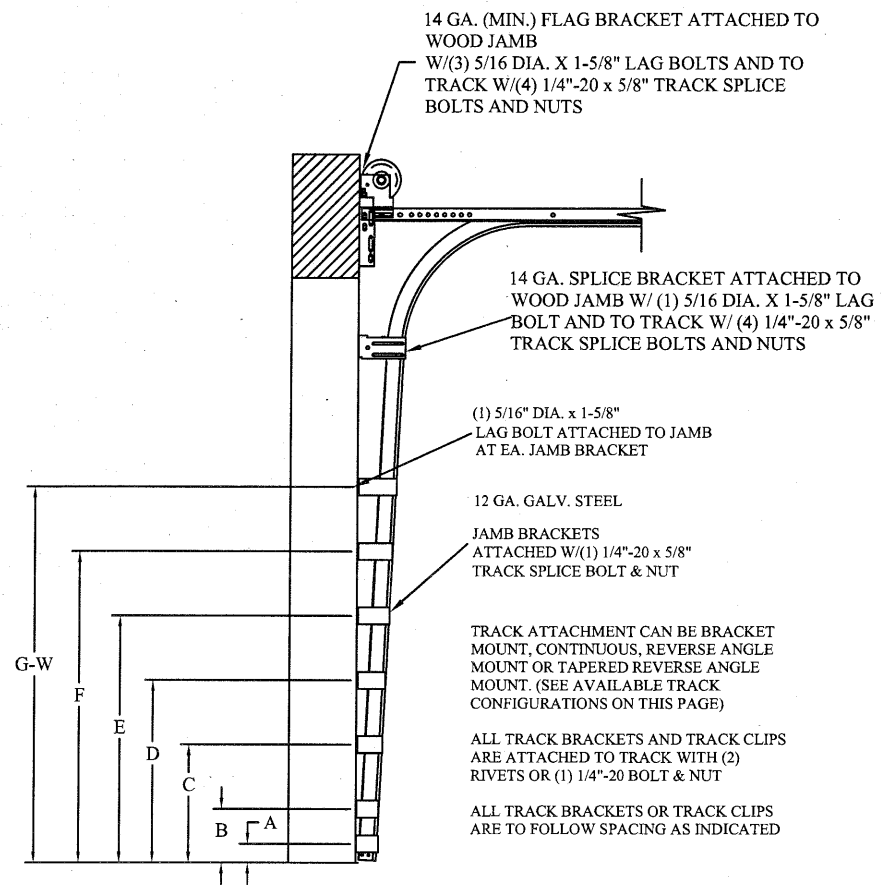

TRACK CONFIGURATION FOR UP TO 24' TALL DOORS
SEE TABLE 1

TABLE 2

Section Width (ft)	Center Stile Locations (Measured from Left Edge)
6' 0"	36"
6' 2"	37"
6' 4"	38"
6' 6"	39"
6' 8"	40"
6' 10"	41"
7' 0"	42"
7' 2"	43"
7' 4"	44"
7' 6"	45"
7' 8"	46"
7' 10"	47"
8' 0"	48"
8' 2"	49"
8' 4"	50"
8' 6"	51"
8' 8"	52"
8' 10"	53"
9' 0"	54"
9' 2"	55"

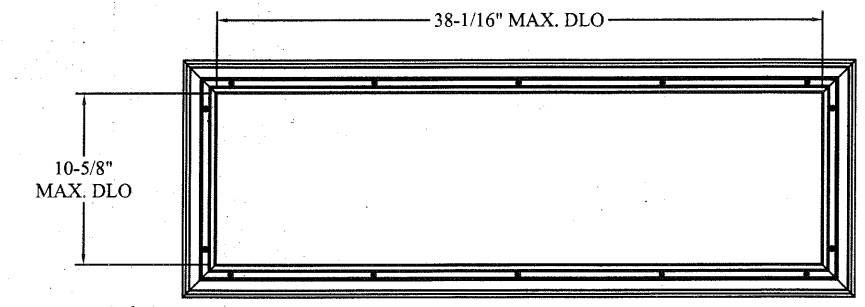

LONG PANEL IMPACT GLAZING FASTENER DETAIL
N.T.S.

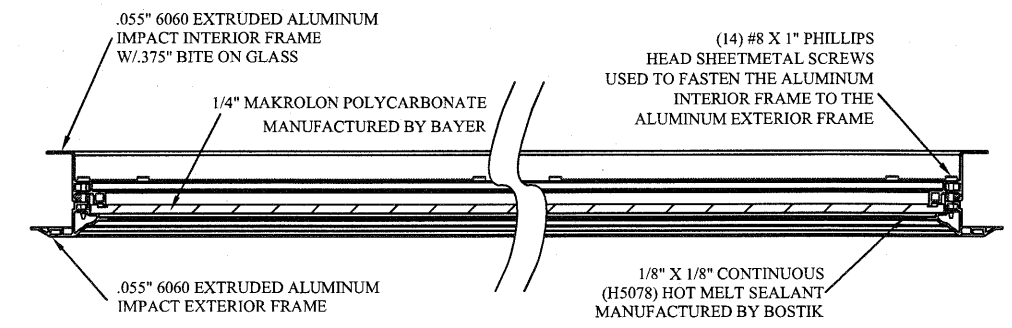

SECTION B-B IMPACT WINDOW DETAIL
N.T.S.

TABLE 1

DOOR HEIGHT	TRACK ATTACHMENT																							
	A	B	C	D	E	F	G	H	I	J	K	L	M	N	O	P	Q	R	S	T	U	V	W	
7' 0"	3.5"	10.0"	22.0"	34"	46"	58"																		
7' 6"	3.5"	10.0"	22.0"	34"	46"	58"	70"																	
8' 0"	3.5"	10.0"	22.0"	34"	46"	58"	70"																	
8' 6"	3.5"	10.0"	22.0"	34"	46"	58"	70"	82"																
9' 0"	3.5"	10.0"	22.0"	34"	46"	58"	70"	82"	94"															
9' 6"	3.5"	10.0"	22.0"	34"	46"	58"	70"	82"	94"															
10' 0"	3.5"	10.0"	22.0"	34"	46"	58"	70"	82"	94"	106"														
11' 0"	3.5"	10.0"	22.0"	34"	46"	58"	70"	82"	94"	106"	118"													
12' 0"	3.5"	10.0"	22.0"	34"	46"	58"	70"	82"	94"	106"	118"	130"												
13' 0"	3.5"	10.0"	22.0"	34"	46"	58"	70"	82"	94"	106"	118"	130"	142"											
14' 0"	3.5"	10.0"	22.0"	34"	46"	58"	70"	82"	94"	106"	118"	130"	142"	154"										
15' 0"	3.5"	10.0"	22.0"	34"	46"	58"	70"	82"	94"	106"	118"	130"	142"	154"	166"									
16' 0"	3.5"	10.0"	22.0"	34"	46"	58"	70"	82"	94"	106"	118"	130"	142"	154"	166"	178"								
17' 0"	3.5"	10.0"	22.0"	34"	46"	58"	70"	82"	94"	106"	118"	130"	142"	154"	166"	178"	190"							
18' 0"	3.5"	10.0"	22.0"	34"	46"	58"	70"	82"	94"	106"	118"	130"	142"	154"	166"	178"	190"	202"						
19' 0"	3.5"	10.0"	22.0"	34"	46"	58"	70"	82"	94"	106"	118"	130"	142"	154"	166"	178"	190"	202"	214"					
20' 0"	3.5"	10.0"	22.0"	34"	46"	58"	70"	82"	94"	106"	118"	130"	142"	154"	166"	178"	190"	202"	214"	226"				
21' 0"	3.5"	10.0"	22.0"	34"	46"	58"	70"	82"	94"	106"	118"	130"	142"	154"	166"	178"	190"	202"	214"	226"	238"			
22' 0"	3.5"	10.0"	22.0"	34"	46"	58"	70"	82"	94"	106"	118"	130"	142"	154"	166"	178"	190"	202"	214"	226"	238"	250"		
23' 0"	3.5"	10.0"	22.0"	34"	46"	58"	70"	82"	94"	106"	118"	130"	142"	154"	166"	178"	190"	202"	214"	226"	238"	250"	262"	
24' 0"	3.5"	10.0"	22.0"	34"	46"	58"	70"	82"	94"	106"	118"	130"	142"	154"	166"	178"	190"	202"	214"	226"	238"	250"	262"	

ALL TRACK ATTACHMENTS +/- 2" ALLOWED USING SYP OR SPF NO.2 OR BETTER ONLY

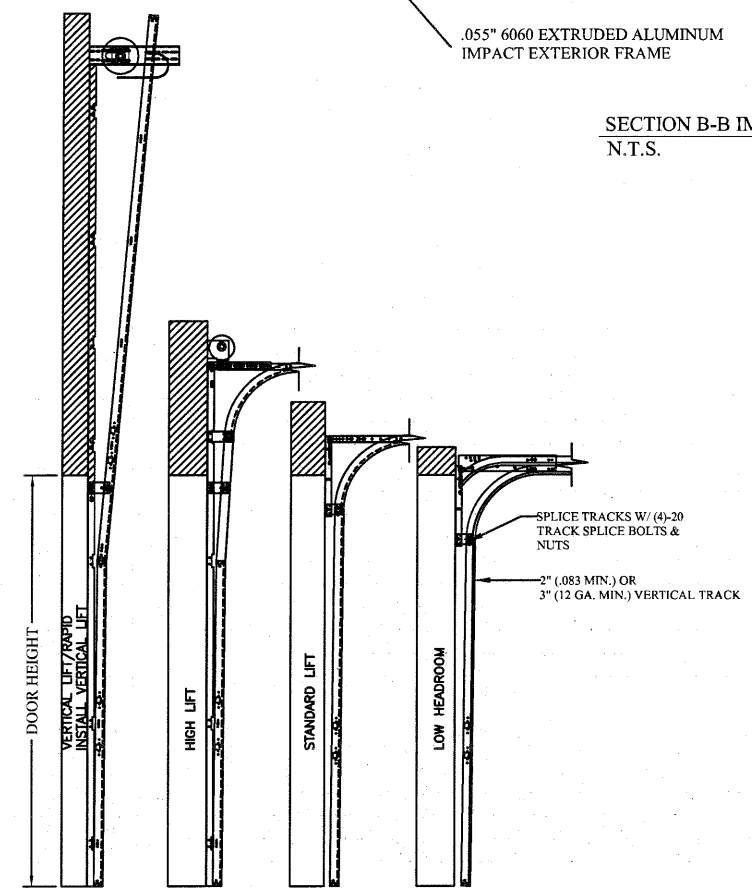

AVAILABLE TRACK CONFIGURATIONS
N.T.S.

REV	DESCRIPTION OF REVISIONS	DATE	BY

MAX SIZE 9'2 x 24'

DESIGN LOADS
+55.1 PSF
-64.5 PSF

TEST LOADS
+82.7 PSF
-96.8 PSF

LARGE MISSILE IMPACT RESISTANCE

Thomas L. Shelmerdine, PE (TX PE #85829)
Structural Solutions, PA (TX Firm #F-004063)

STATE OF TEXAS
THOMAS L. SHELMERDINE
85829
LICENSED PROFESSIONAL ENGINEER
TX

5921-G W. Friendly Ave., Greensboro, NC 27410

Amarr
ENTREMATIC

MODEL 1000 AMARR 2432

SIZE	DRAWN BY DRD	DATE 6/5/17	DRAWING NUMBER
B	CHECKED BY RLR	DATE 6/5/17	IBC-1009-195-15-F

ENTREMATIC
165 CARRIAGE COURT WINSTON-SALEM, N.C. 27105

SHEET 3 OF 3