

TYPICAL TOP FIXTURE  
N.T.S. 1

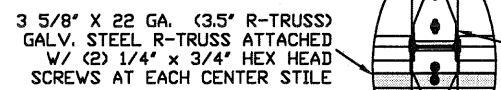

TYPICAL CENTER HINGE  
N.T.S. 2

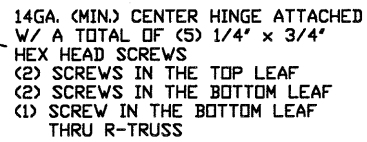

2" THICK

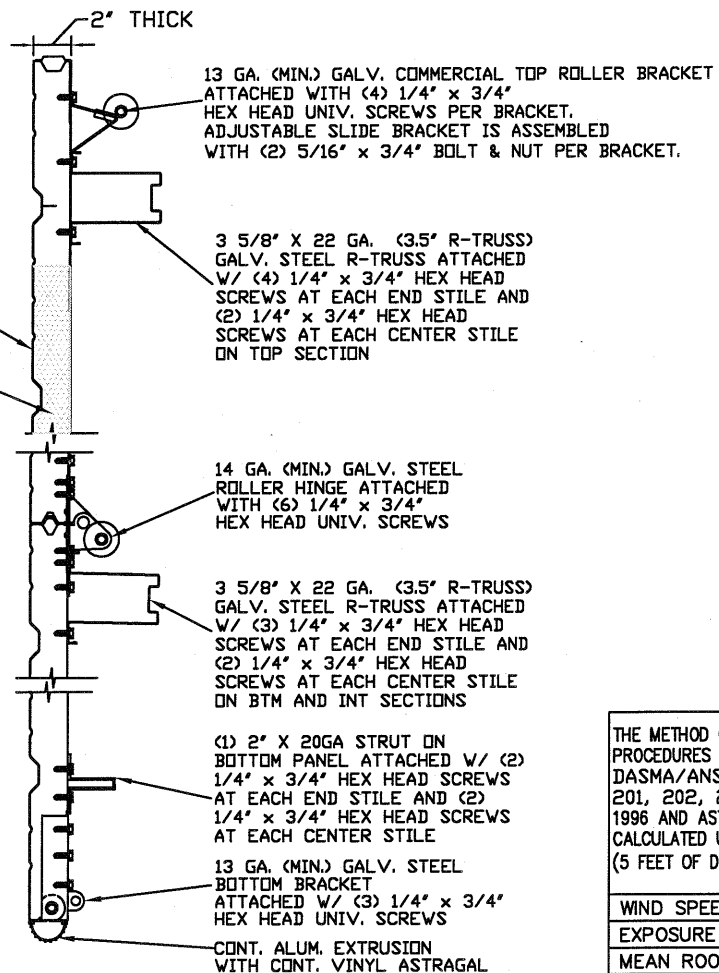

SECTION A-A (SIDE VIEW)

# LARGE MISSILE IMPACT RESISTANCE

THE METHOD OF TESTING WAS IN SUBSTANTIAL CONFORMANCE WITH THE PROCEDURES DESCRIBED IN ASTM E330, ANSI/DASMA 108, DASMA/ANSI 115 FLA. BUILDING CODE PROTOCOLS TAS 201, 202, 203 WIND LOAD DESIGN CRITERIA, ASTM E 1886, ASTM E 1996 AND ASTM F588. THE PRESSURES SHOWN ON THE DRAWINGS WERE CALCULATED USING ASCE 7-16 WITH THE FOLLOWING PARAMETERS (5 FEET OF DOOR WIDTH IN END ZONE, ROOF SLOPE 10° OR LESS):

WIND SPEED (MPH)	240	218	207	198	190
EXPOSURE LEVEL	B	C	C	D	D
MEAN ROOF HEIGHT	30'	15'	25'	15'	25'

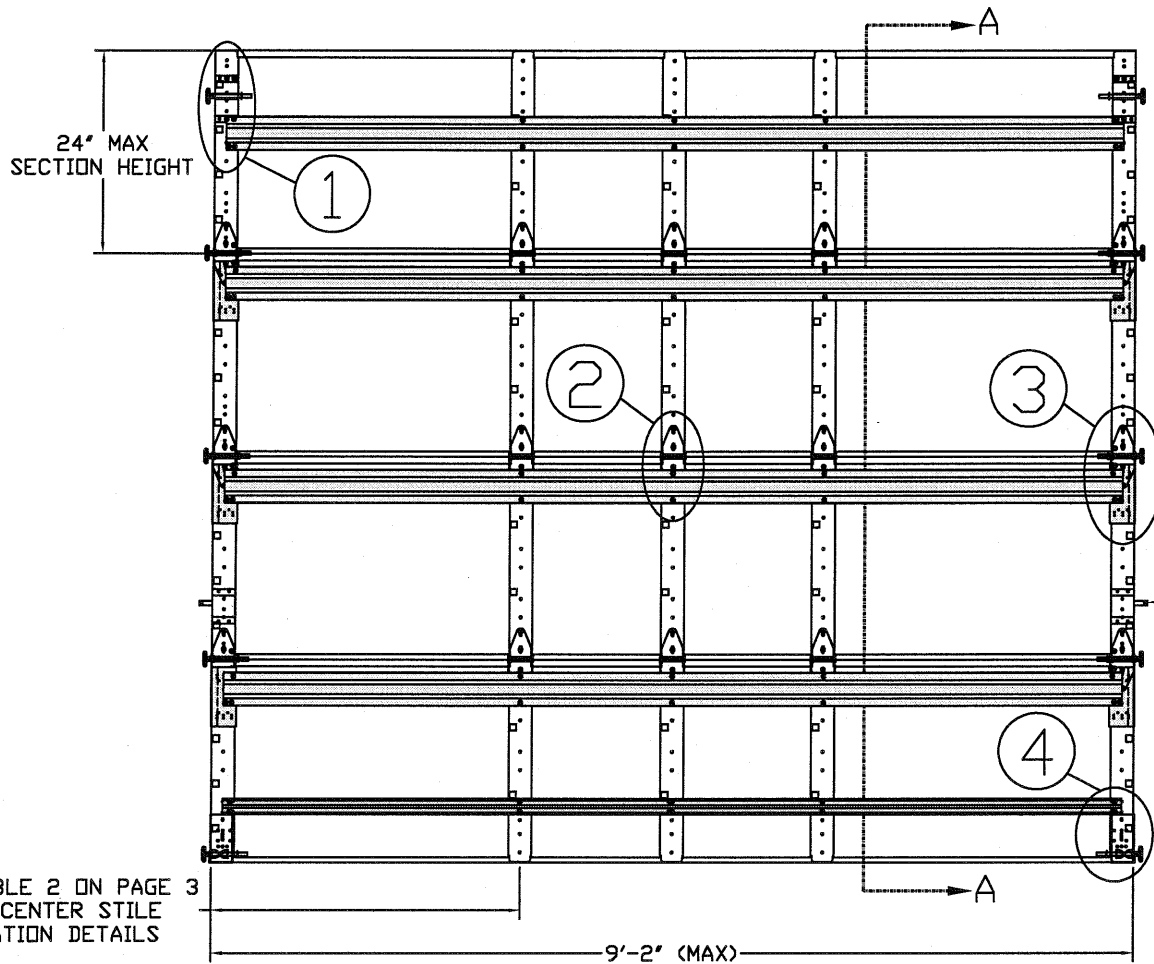

INSIDE ELEVATION  
N.T.S.

SEE TABLE 2 ON PAGE 3 FOR CENTER STILE LOCATION DETAILS

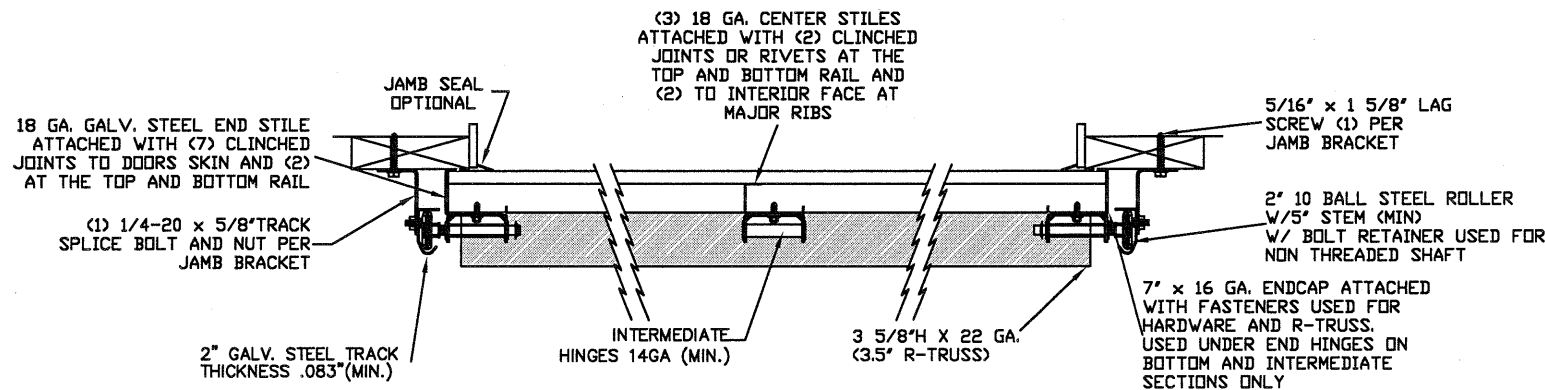

TRACK MOUNTING DETAIL  
N.T.S.

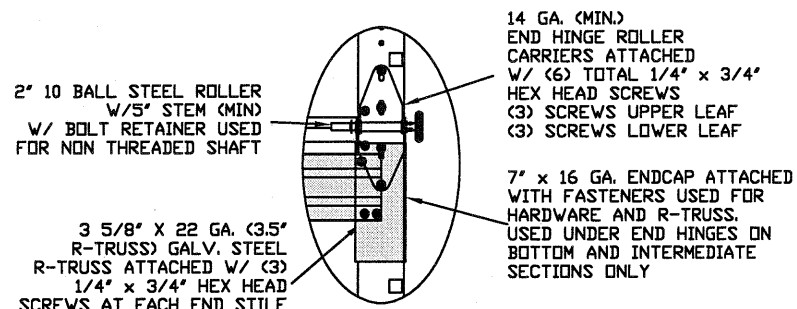

TYPICAL END HINGE  
N.T.S. 3

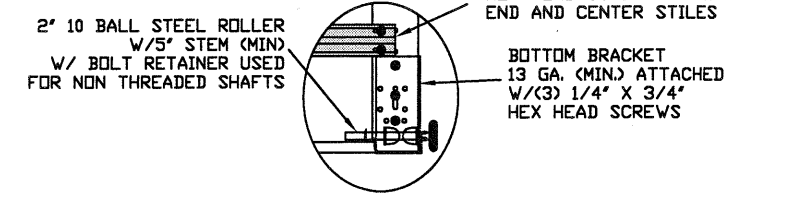

TYPICAL BOTTOM BRACKET  
N.T.S. 4

REV	DESCRIPTION OF REVISIONS	DATE	BY

MAX SIZE WIDTH 9'2" HEIGHT 24'1"

DESIGN LOADS +50.0 PSF -62.0 PSF

LARGE MISSILE IMPACT RESISTANCE

Thomas L. Shelmerdine, PE (TX PE #85829) Structural Solutions, PA (TX Firm #F-004063)

STATE OF TEXAS  
THOMAS L. SHELMERDINE  
85829  
LICENSED PROFESSIONAL ENGINEER  
TX

5921-G W. Friendly Ave., Greensboro, NC 27410

**Amarr**

MODEL 2400 AMARR 2402, 2412, 2422 (24 GA)  
MODEL 2000 AMARR 2002, 2012, 2022 (20 GA)

SIZE	DRAWN BY	SKW	DATE	07/29/08	DRAWING NUMBER
B	CHECKED BY	SKW	DATE	07/29/08	IRC-2409-177-21-I

AMARR COMPANY  
165 CARRIAGE COURT WINSTON-SALEM, N.C. 27105

SHEET 1 OF 3

# TRACK CONNECTION DIRECTLY TO STRUCTURE OPTIONS

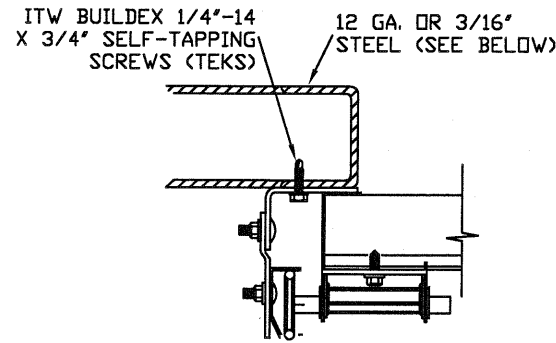

CLIP STYLE REVERSE ANGLE MOUNT SHOWN  
BRACKET, CONTINUOUS AND TAPERED ANGLE  
MOUNT AVAILABLE

12 GA. STEEL FRAMING  
232 LBS./SCREW ALLOWABLE LOAD - 3'  
FROM ENDS AND 12' O.C.  
REFER TO NOTES: 1, 2 AND 5

3/16\"/>

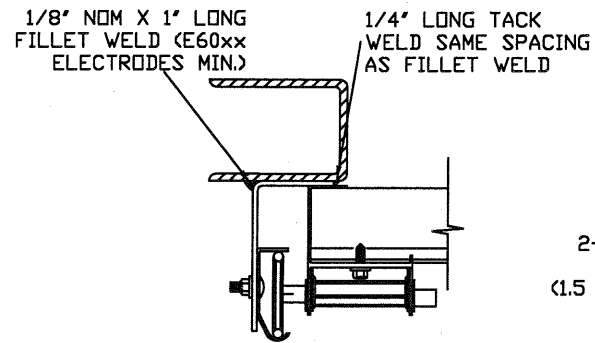

REVERSE ANGLE MOUNT SHOWN  
BRACKET, CONTINUOUS AND  
TAPERED ANGLE MOUNT AVAILABLE

STEEL FRAMING 12GA OR BETTER  
1590 LBS./IN. ALLOWABLE LOAD -  
6' FROM ENDS AND 24' O.C.  
REFER TO NOTES: 1, 2, 5, 6, 7, 8  
AND 9

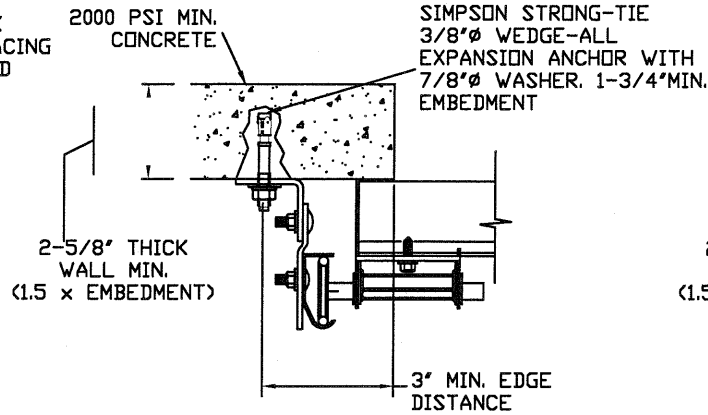

CLIP STYLE CONTINUOUS ANGLE MOUNT SHOWN  
BRACKET, REVERSE AND TAPERED ANGLE MOUNT  
AVAILABLE

2000 PSI CONCRETE OR GREATER  
351 LBS./EXPANSION ANCHOR ALLOWABLE LOAD -  
6' FROM ENDS AND 18' O.C.  
REFER TO NOTES: 1, 2, 3, 4 AND 5

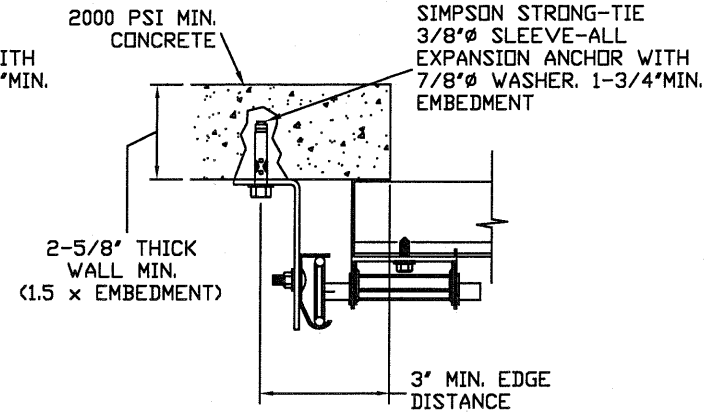

CONTINUOUS ANGLE MOUNT SHOWN  
BRACKET, CONTINUOUS AND TAPERED ANGLE  
MOUNT AVAILABLE

2000 PSI CONCRETE OR GREATER  
336 LBS./EXPANSION ANCHOR ALLOWABLE  
LOAD - 6' FROM ENDS AND 16' O.C.  
REFER TO NOTES: 1, 2, 3, 4 AND 5

NOTES:

- ANCHORS TO BE EVENLY SPACED BETWEEN THE HEADER AND FLOOR.
- FIRST (BOTTOM) ANCHOR STARTING AT NO MORE THAN HALF OF THE MAXIMUM ON-CENTER DISTANCE. HIGHEST ANCHOR INSTALLED AT LEAST AS HIGH AS THE DOOR OPENING.
- MIN. EDGE DISTANCE OF 3' REQUIRED.
- USE WASHERS PROVIDED BY THE ANCHOR MANUFACTURER.
- SUPPORTING STRUCTURAL ELEMENTS SHALL BE DESIGNED BY A REGISTERED PROFESSIONAL ENGINEER FOR WIND LOADS IN ADDITION TO OTHER LOADS.
- MOST GARAGE DOOR TRACK IS GALVANIZED STEEL. USE ALL NECESSARY PRECAUTIONS WHEN WELDING GALVANIZED STEEL.
- ALL WELDS SHOULD BE PERFORMED BY A CERTIFIED WELDER OR INSPECTED BY A CERTIFIED WELDING INSPECTOR TO VERIFY THE INTEGRITY OF THE WELD.
- FILLET WELDS TO HAVE A STRAIGHT OR CONVEX FACE SURFACE.
- TACK WELD TOE OF ANGLE AT SAME SPACING TO PREVENT ROTATION OF TRACK ANGLE.

TABLE 1

DOOR HEIGHT	TRACK ATTACHMENT																			SPLICE S				
	A	B	C	D	E	F	G	H	I	J	K	L	M	N	O	P	Q	R	S		T	U	V	W
7'	3.5"	10"	22"	34"	46"	58"																		76"
8'	3.5"	10"	22"	34"	46"	58"	70"																	88"
9'	3.5"	10"	22"	34"	46"	58"	70"	82"																100"
10'	3.5"	10"	22"	34"	46"	58"	70"	82"	94"															112"
11'	3.5"	10"	22"	34"	46"	58"	70"	82"	94"	106"														124"
12'	3.5"	10"	22"	34"	46"	58"	70"	82"	94"	106"	118"													136"
13'	3.5"	10"	22"	34"	46"	58"	70"	82"	94"	106"	118"	130"												148"
14'	3.5"	10"	22"	34"	46"	58"	70"	82"	94"	106"	118"	130"	142"											160"
15'	3.5"	10"	22"	34"	46"	58"	70"	82"	94"	106"	118"	130"	142"	154"										172"
16'	3.5"	10"	22"	34"	46"	58"	70"	82"	94"	106"	118"	130"	142"	154"	166"									184"
17'	3.5"	10"	22"	34"	46"	58"	70"	82"	94"	106"	118"	130"	142"	154"	166"	178"								196"
18'	3.5"	10"	22"	34"	46"	58"	70"	82"	94"	106"	118"	130"	142"	154"	166"	178"	190"							208"
19'	3.5"	10"	22"	34"	46"	58"	70"	82"	94"	106"	118"	130"	142"	154"	166"	178"	190"	202"						220"
20'	3.5"	10"	22"	34"	46"	58"	70"	82"	94"	106"	118"	130"	142"	154"	166"	178"	190"	202"	214"					232"
21'	3.5"	10"	22"	34"	46"	58"	70"	82"	94"	106"	118"	130"	142"	154"	166"	178"	190"	202"	214"	226"				244"
22'	3.5"	10"	22"	34"	46"	58"	70"	82"	94"	106"	118"	130"	142"	154"	166"	178"	190"	202"	214"	226"	238"			256"
23'	3.5"	10"	22"	34"	46"	58"	70"	82"	94"	106"	118"	130"	142"	154"	166"	178"	190"	202"	214"	226"	238"	250"		268"
24'	3.5"	10"	22"	34"	46"	58"	70"	82"	94"	106"	118"	130"	142"	154"	166"	178"	190"	202"	214"	226"	238"	250"	262"	280"

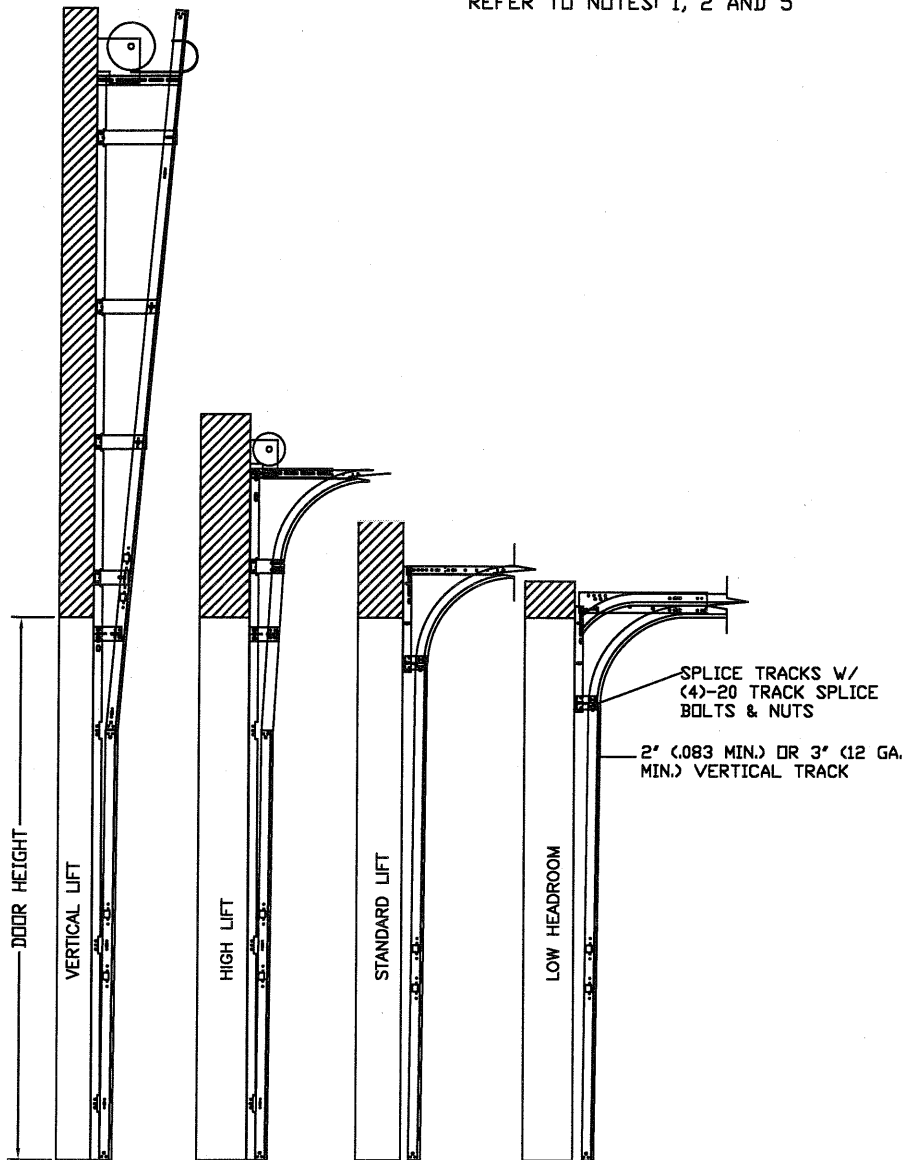

AVAILABLE TRACK CONFIGURATIONS  
N.T.S.

REV	DESCRIPTION OF REVISIONS	DATE	BY

MAX SIZE  
WIDTH 9'2"  
HEIGHT 24'1"

DESIGN LOADS  
+50.0 PSF  
-62.0 PSF

LARGE MISSILE  
IMPACT  
RESISTANCE

Thomas L. Shelmerdine, PE (TX PE #85829)  
Structural Solutions, PA (TX Firm #F-004063)

STATE OF TEXAS  
THOMAS L. SHELMERDINE  
85829  
LICENSED PROFESSIONAL ENGINEER  
TX

5921-G W. Friendly Ave., Greensboro, NC 27410

# Amarr

MODEL 2400 AMARR 2402, 2412, 2422 (24 GA)  
MODEL 2000 AMARR 2002, 2012, 2022 (20 GA)

SIZE	DRAWN BY	SKW	DATE	07/29/08	DRAWING NUMBER
B	CHECKED BY	SKW	DATE	07/29/08	IRC-2409-177-21-I

AMARR COMPANY  
165 CARRIAGE COURT WINSTON-SALEM, N.C. 27105

SHEET 2 OF 3

# TRACK CONNECTION TO WOOD JAMB OPTIONS

FOR LAG SCREWS & BRACKET SPACING SEE TABLE 1

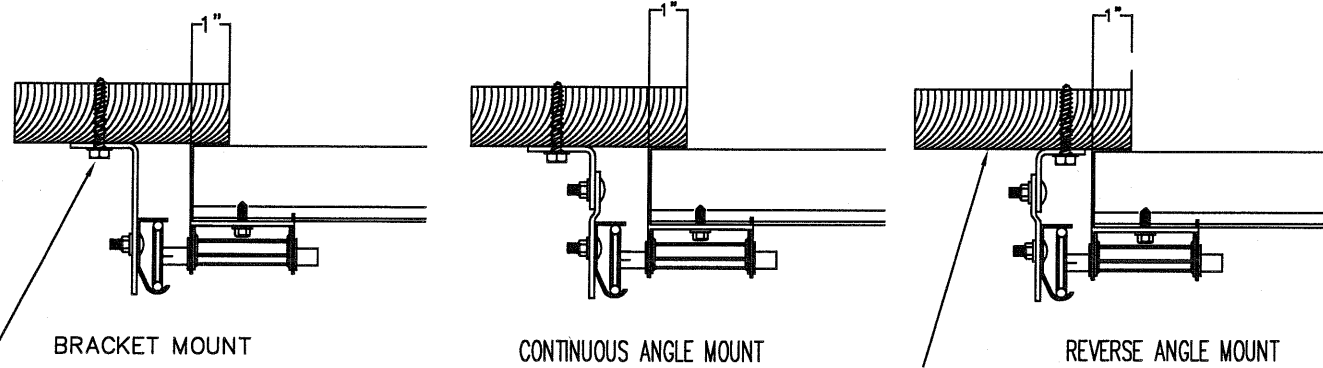

5/16" x 1 5/8" LAG SCREW (1)  
PER JAMB BRACKET (1-1/2"  
EMBEDMENT MINIMUM) (TYP.)

2x6 WOOD JAMB SYP  
(NO.2) OR BETTER (TYP.)

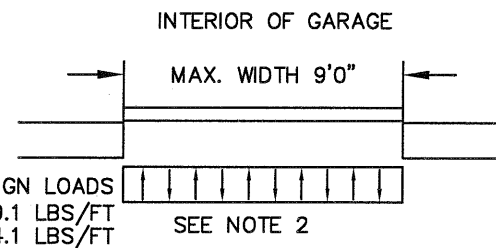

## SPECIFICATIONS AND NOTES

- ALL THE LOAD FROM THE DOOR IS TRANSFERRED TO THE VERTICAL TRACK, FROM THE TRACK THE LOAD IS TRANSFERRED TO THE VERTICAL JAMBS. THE HORIZONTAL JAMB OR HEADER RECEIVES NO PORTION OF THE LOAD TRANSFERRED FROM THE DOOR.
- EACH VERTICAL JAMBS RECEIVES MAXIMUM DESIGN LOADS OF: +229.1 LBS/FT & -284.1 LBS/FT
- DOOR AND HARDWARE WILL BE DESIGNED, MANUFACTURED AND INSTALLED WITH STANDARDS AS SET FORTH BY DASMA.
- DOOR SECTIONS SHALL BE 24 GA. (.022) MIN. EXTERIOR SKIN ROLLED FORMED, W/ BAKED ON POLYESTER FINISH
- DOORS UP TO 24'0" HIGH USE (1) 3 5/8" R-TRUSS PER SECTION AND (1) 2" 20GA STRUT ON BOTTOM SECTION
- SUPPORTING STRUCTURAL ELEMENTS SHALL BE DESIGNED BY A REGISTERED PROFESSIONAL ENGINEER FOR WIND LOADS INDICATED ON THIS DRAWING IN ADDITION TO OTHER LOADINGS.
- DOOR IS MANUFACTURED AND TESTED IN ACCORDANCE WITH THE 2018 IRC/IBC

# WOOD JAMB ATTACHMENT TO STRUCTURE (OPTIONAL)

- 2 X 6 VERTICAL JAMB ATTACHMENT TO WOOD FRAME STRUCTURE  
5/16" X 3" LAG SCREWS STARTING 6" FROM ENDS THEN 20" O.C. (1 1/2" EMBEDMENT)
- 2 X 6 VERTICAL JAMB ATTACHMENT TO 2,000 PSI CONCRETE  
HILTI KWIK BOLT 3/8" X 4" STARTING 6" FROM ENDS THEN 24" O.C. (2 1/2" EMBEDMENT)  
HILTI SLEEVE ANCHOR 3/8" X 2-3/4" STARTING 6" FROM ENDS THEN 18" O.C. (1 1/4" EMBEDMENT)  
ITW/RAMSET REDHEAD (TRU-BOLT) 3/8" X 4" STARTING 6" FROM ENDS THEN 24" O.C. (2 1/2" EMBEDMENT)
- 2 X 6 VERTICAL JAMB ATTACHMENT TO HOLLOW C-90 BLOCK  
SIMPSON 1/4" X 3" TITEN SCREWS STARTING 6" FROM ENDS, USE PAIRS OF FASTENERS (3" APART) AT 8" O.C. (1 1/2" EMBEDMENT)  
HILTI 1/4" X 2-3/4" KWIK-CON II+ SCREWS STARTING 6" FROM ENDS, USE PAIRS OF FASTENERS (3" APART) AT 8" O.C. (1 1/4" EMBEDMENT)
- 2 X 6 VERTICAL JAMB ATTACHMENT TO GROUTED C-90 BLOCK (2000 PSI GROUT)  
HILTI SLEEVE ANCHOR 3/8" X 2-3/4" STARTING 6" FROM ENDS THEN 22" O.C. (1 1/4" EMBEDMENT) (OR, USE FASTENERS FOR HOLLOW C-90 BLOCK)

\*LAGS AND BOLTS CAN BE COUNTERSUNK TO PROVIDE A FLUSH MOUNTING SURFACE.  
\*PREPARATION OF WOOD JAMBS BY OTHERS

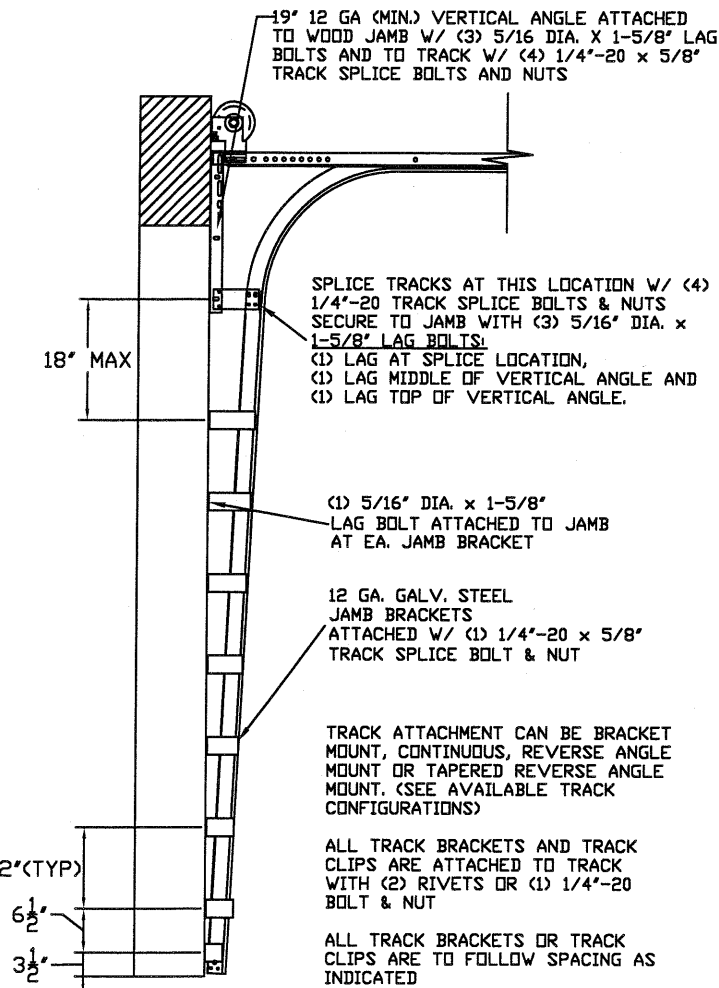
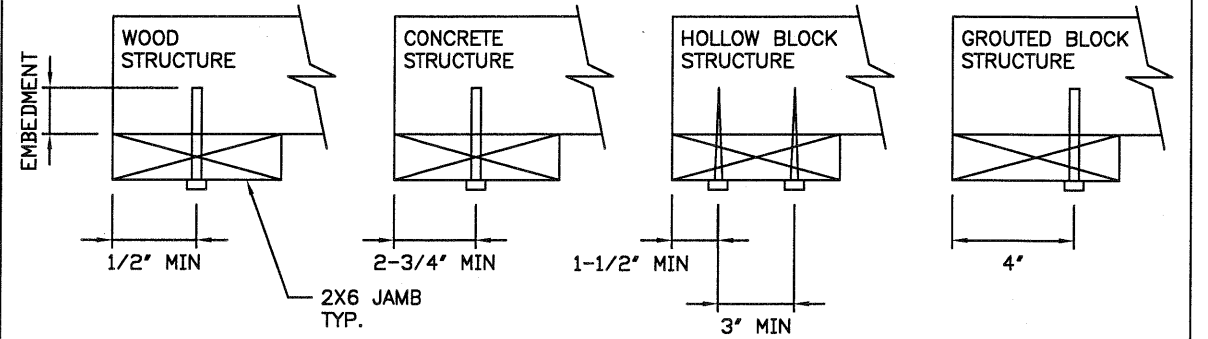

TRACK CONFIGURATION FOR UP TO 24' TALL DOORS

## TABLE 2

Section	Center Stile Locations (Measured from Left Edge)		
	Width (ft)	1st (in)	2nd (in)
6'0	18.00"	36.00"	54.00"
6'2	19.00"	37.00"	55.00"
6'4	20.00"	38.00"	56.00"
6'6	21.00"	39.00"	57.00"
6'8	22.00"	40.00"	58.00"
6'10	23.00"	41.00"	59.00"
7'0	24.00"	42.00"	60.00"
7'2	25.00"	43.00"	61.00"
7'4	26.00"	44.00"	62.00"
7'6	27.00"	45.00"	63.00"
7'8	28.00"	46.00"	64.00"
7'10	29.00"	47.00"	65.00"
8'0	30.00"	48.00"	66.00"
8'2	31.00"	49.00"	67.00"
8'4	32.00"	50.00"	68.00"
8'6	33.00"	51.00"	69.00"
8'8	34.00"	52.00"	70.00"
8'10	35.00"	53.00"	71.00"
9'0	36.00"	54.00"	72.00"
9'2	37.00"	55.00"	73.00"

REV	DESCRIPTION OF REVISIONS	DATE	BY

MAX SIZE  
WIDTH 9'2"  
HEIGHT 24'1"

DESIGN LOADS  
+50.0 PSF  
-62.0 PSF

LARGE MISSILE  
IMPACT  
RESISTANCE

Thomas L. Shelmerdine, PE (TX PE #85829)  
Structural Solutions, PA (TX Firm #0-04063)

STATE OF TEXAS  
THOMAS L. SHELMERDINE  
85829  
LICENSED PROFESSIONAL ENGINEER  
TX

5921-G W. Friendly Ave., Greensboro, NC 27410

**Amarr**

MODEL 2400 AMARR 2402, 2412, 2422 (24 GA)  
MODEL 2000 AMARR 2002, 2012, 2022 (20 GA)

SIZE	DRAWN BY	SKW	DATE	07/29/08	DRAWING NUMBER
B	CHECKED BY	SKW	DATE	07/29/08	IRC-2409-177-21-I

AMARR COMPANY  
165 CARRIAGE COURT WINSTON-SALEM, N.C. 27105

SHEET 3 OF 3