

NOTES:

1. STANDARD GLAZING OPTION - .125" MINIMUM DSB GLAZING MEETS UNIFORM STATIC DESIGN PRESSURES SHOWN ON THIS DRAWING. GLAZING SHALL HAVE A MAXIMUM HEIGHT OF 6.70" AND A MAXIMUM LENGTH OF 24.00". GLAZING IS NOT IMPACT RESISTANT AND DOES NOT MEET THE REQUIREMENTS FOR WIND-BORNE DEBRIS REGIONS.

2. ALUMINUM FULL VIEW OPTION - ALUMINUM FULL VIEW SECTION MAY REPLACE ANY SECTION EXCEPT TOP AND BOTTOM PANELS. ALUMINUM FULL VIEW SECTION SHALL HAVE RAILS AND STILES OF EXTRUDED ALUMINUM ALLOY 6063-T6 AND .125" MINIMUM DSB GLAZING INSTALLED WITH ALUMINUM RETAINERS IN ORDER TO MEET UNIFORM STATIC DESIGN PRESSURES SHOWN ON THIS DRAWING. AFV PANEL SIZE IS 51.5"x21.9" (MAX). GLAZING IS NOT IMPACT RESISTANT AND DOES NOT MEET THE REQUIREMENTS FOR WIND-BORNE DEBRIS REGIONS.

3. MINIMUM OF 1" OVERLAP ON BOTH JAMBS REQUIRED TO MEET NEGATIVE DESIGN PRESSURES.

4. SLIDE LOCK OR OPERATOR REQUIRED.

5. SECTION STEEL TO HAVE THE FOLLOWING MINIMUM THICKNESS:
 C20 - 20 GA
 C24 - 24 GA
 C2400 - 25 GA

6. THE DESIGN OF THE SUPPORTING STRUCTURAL ELEMENTS SHALL BE THE RESPONSIBILITY OF THE PROFESSIONAL OF RECORD FOR THE BUILDING OR STRUCTURE AND IN ACCORDANCE WITH CURRENT BUILDING CODES FOR THE LOADS LISTED ON THIS DRAWING.

7. TRACK CLIPS SHALL BE LOCATED WITH CENTERLINE OF BOTTOM CLIP SPACED 10" MAX FROM BOTTOM OF TRACK AND REMAINING TRACK CLIPS SPACED AT 24" O.C. MAX. SPACING BETWEEN TOP TRACK CLIP AND SPLICE PLATE SHALL BE 30" O.C. MAX.

8. WHEN MOUNTING TO WOOD, DOOR JAMB TO BE MINIMUM 2x6 STRUCTURAL GRADE LUMBER. REFER TO JAMB CONNECTION SUPPLEMENT FOR ATTACHMENT TO SUPPORTING STRUCTURE.

5/16"x1-5/8" LAG SCREW AT EACH HOLE LOCATION FOR WOOD SUBSTRATE. SEE SHEET 3 FOR MOUNTING TO OTHER SUBSTRATES.

(1) 1/4-20x9/16" TRACK BOLTS AND 1/4-20 HEX NUTS AT EACH TRACK CLIP LOCATION (SEE DETAIL A SHEET 3)

11 GA TRACK CLIPS (WELDED, BOLTED, OR RIVETED TO WALL ANGLE) SEE NOTE 7 AND DETAIL F SHEET 3

SLIDE LOCK ONE END (NOT REQUIRED WITH OPERATOR - SEE NOTE 4)

NOTE: (4) SECTION SOLID DOOR SHOWN. SEE SHEET 2 FOR U-BAR LOCATIONS ON DOORS WITH OTHER SECTION QUANTITIES AND SEE NOTES 1 & 2 THIS SHEET FOR GLAZING OPTIONS.

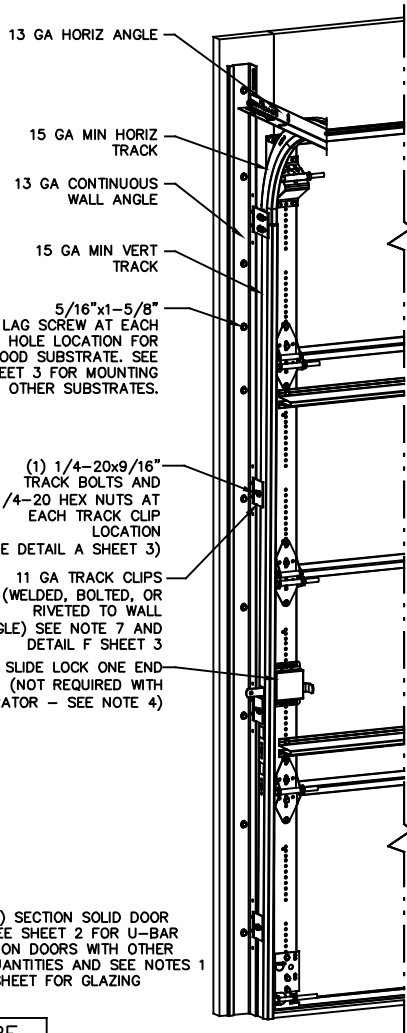

SUPERIMPOSED DESIGN PRESSURE LOADS ON SUPPORTING STRUCTURE		
MAX DOOR WIDTH	DOOR HEIGHT	MAX UNIFORM LOAD EACH JAMB (PLF)
9'-4"	ALL	+73.9/-84.6

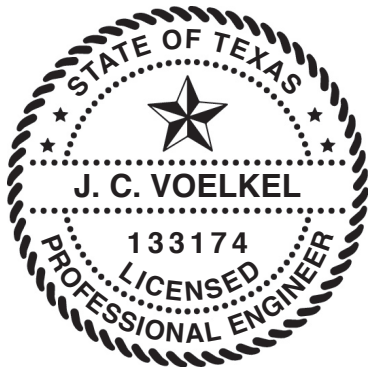

J. CHRISTIAN VOELKEL, PE
 312 N. NEW WARRINGTON ROAD, UNIT 1A
 PENSACOLA, FL
 FL PE 82229
 TX PE 133174

PROFESSIONAL ENGINEER'S SEAL PROVIDED ONLY FOR VERIFICATION OF WINDLOAD CONSTRUCTION DETAILS.

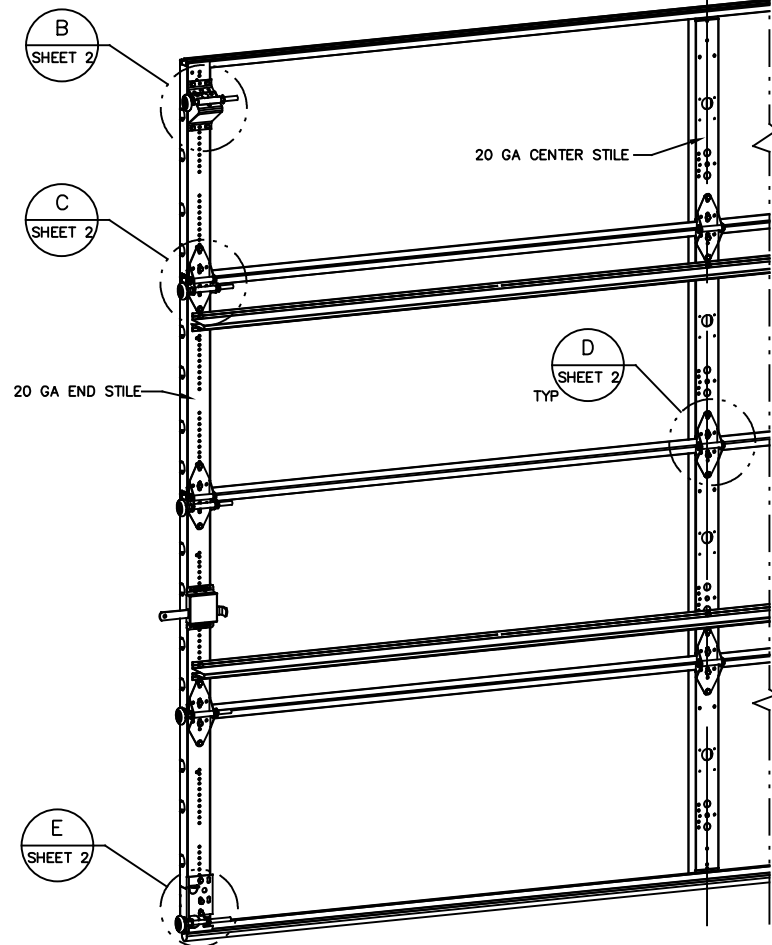

REVISIONS
 REV - INITIAL DRAWING WLO05 08/12/20 TLC
 REV A - ADDED SIZE OF AFV PANEL TLC 4/28/21

THE DOORS ARE DESIGNED AND MANUFACTURED TO COMPLY WITH THE 2018 IRC AND THE 2018 IBC.

 A DIVISION OF OVERHEAD DOOR CORP 3395 ADDISON DRIVE PENSACOLA, FLORIDA 32514 (850) 474-9890	STATIC PRESSURE RATINGS DESIGN (PSF): +15.90/-18.20 TEST (PSF): +23.85/-27.30 IMPACT/CYCLIC RATED (YES/NO): NO		APPROVED SIZES MAX WIDTH: 9'-4" MAX HEIGHT: 24'-1" MAX SECTION HEIGHT: 24"		SCALE: N.T.S. DATE: 8/12/20 CHECKED: 4/28/21		SIZE: A NAME: TLC TLC	
	MODELS C20/C24/C2400						SHEET 1 OF 3	
	WINDLOAD SPECIFICATION OPTION CODE 2061						DRAWING PART NO. 365564	

1/4-20x9/16" TRACK BOLT AND 1/4-20 HEX NUT THROUGH THE SLOT IN THE TRACK AND TRACK CLIP

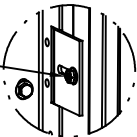

DETAIL A

12 GA COMMERCIAL 'A' FRAME BRACKET ASSEMBLY WITH 13 GA ROLLER CARRIER ATTACHED WITH (4) 1/4-14x7/8" SELF DRILLING CRIMPITITE SCREWS

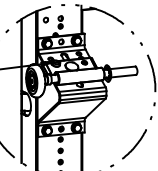

DETAIL B

2" STEEL ROLLER WITH 5-1/8" STEM AND 7/16" PUSHNUT AT EACH ROLLER LOCATION. 1/4" MAX BETWEEN PUSHNUT AND BRACKET OR HINGE

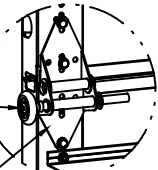

DETAIL C

14 GA WIDE BODY END HINGE TO ATTACH SECTIONS ONE AND TWO.
13 GA WIDE BODY END HINGE TO ATTACH REMAINING SECTIONS. FOR ALL, ATTACH WITH (4) 1/4-14x7/8" SELF DRILLING CRIMPITITE SCREWS

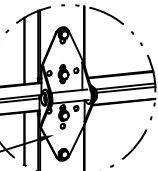

DETAIL D

14 GA WIDE BODY INTERMEDIATE HINGE ATTACHED WITH (4) 1/4-14x7/8" SELF DRILLING CRIMPITITE SCREWS

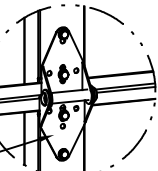

DETAIL D

12 GA BOTTOM BRACKET ATTACHED WITH (3) 1/4-14x7/8" SELF DRILLING CRIMPITITE SCREWS

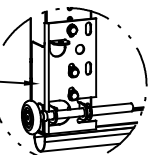

DETAIL E

ATTACH U-BARS WITH (2) 1/4-14x7/8" SELF DRILLING CRIMPITITE SCREWS AT ALL STILE LOCATIONS, TYP.

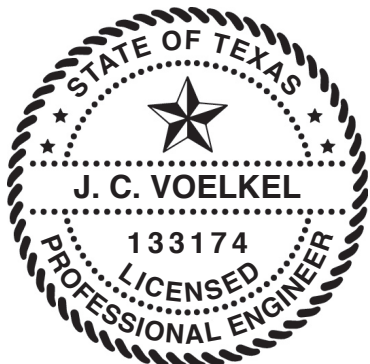
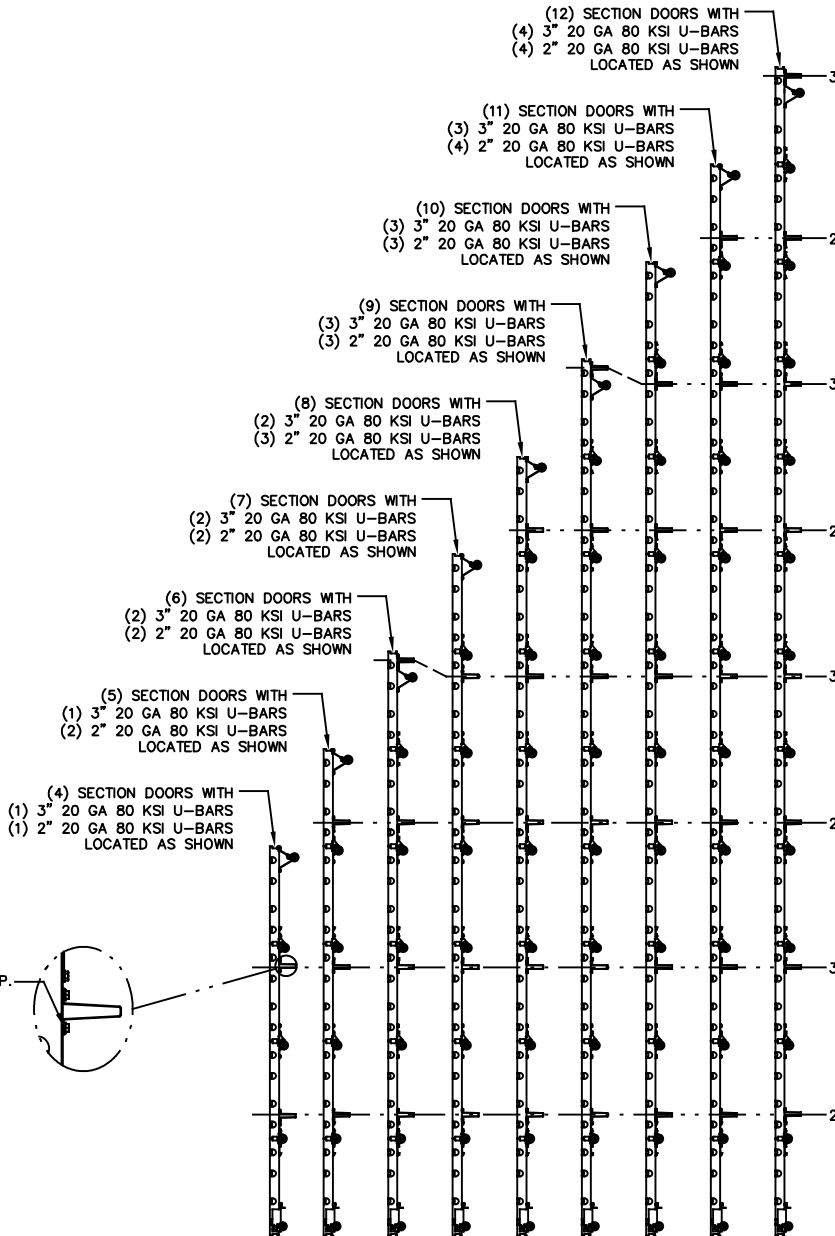

J. CHRISTIAN VOELKEL, PE
312 N. NEW WARRINGTON ROAD, UNIT 1A
PENSACOLA, FL
FL PE 82229
TX PE 133174

PROFESSIONAL ENGINEER'S SEAL PROVIDED ONLY FOR VERIFICATION OF WINDLOAD CONSTRUCTION DETAILS.

Wayne Dalton
GARAGE DOORS™

A DIVISION OF OVERHEAD DOOR CORP.
3395 ADDISON DRIVE
PENSACOLA, FLORIDA 32514
(850) 474-9890

STATIC PRESSURE RATINGS		APPROVED SIZES		SCALE: N.T.S.		SIZE: A	
DESIGN (PSF):	+15.90/-18.20	MAX WIDTH:	9'-4"	DATE	NAME		
TEST (PSF):	+23.85/-27.30	MAX HEIGHT:	24'-1"	DRAWN	TLC		
IMPACT/CYCLIC RATED (YES/NO): NO		MAX SECTION HEIGHT: 24"	CHECKED	4/28/21		TLC	
MODELS C20/C24/C2400				SHEET 2 OF 3			
WINDLOAD SPECIFICATION OPTION CODE 2061				DRAWING PART NO.		REV.	
				365564		A	

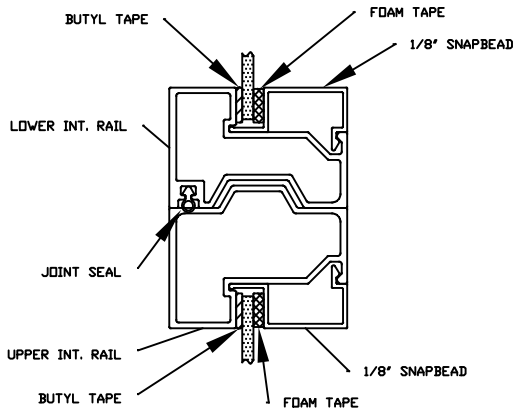

**ALUMINUM FULL VIEW
1/8" GLAZING OPTION**

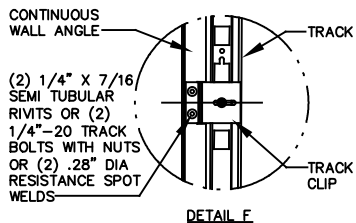
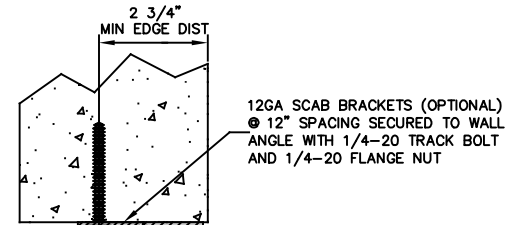
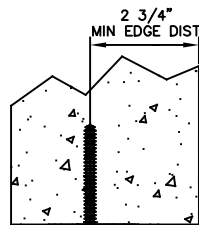
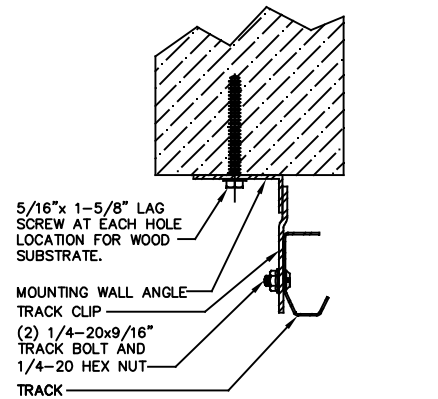
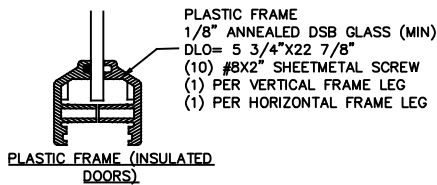
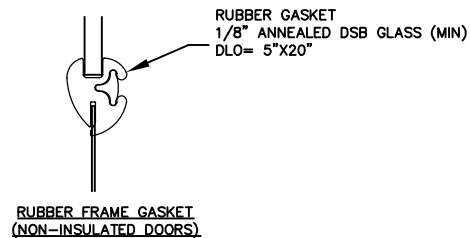

EXTERIOR FRAME

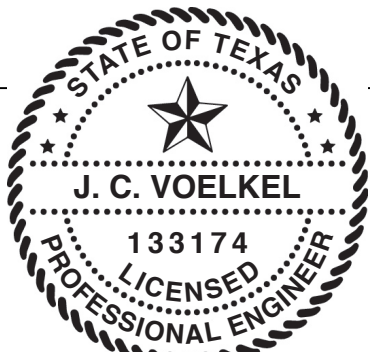
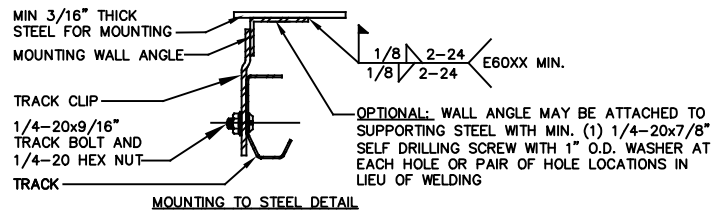

J. CHRISTIAN VOELKEL, PE
312 N. NEW WARRINGTON ROAD, UNIT 1A
PENSACOLA, FL
FL PE 82229
TX PE 133174

PROFESSIONAL ENGINEER'S SEAL PROVIDED ONLY FOR VERIFICATION OF WINDLOAD CONSTRUCTION DETAILS.

<p>Wayne Dalton GARAGE DOORS™</p> <p>A DIVISION OF OVERHEAD DOOR CORP. 3395 ADDISON DRIVE PENSACOLA, FLORIDA 32514 (850) 474-9890</p>	STATIC PRESSURE RATINGS	APPROVED SIZES	SCALE: N.T.S.	SIZE: A
	DESIGN (PSF): +15.90/-18.20	MAX WIDTH: 9'-4"	DATE	NAME
	TEST (PSF): +23.85/-27.30	MAX HEIGHT: 24'-1"	DRAWN	TLC
	IMPACT/CYCLIC RATED (YES/NO): NO	MAX SECTION HEIGHT: 24"	CHECKED	TLC
	MODELS C20/C24/C2400		SHEET 3 OF 3	
	WINDLOAD SPECIFICATION OPTION CODE 2061	DRAWING PART NO.	REV.	
		365564	A	