

CLIPS TO BE EITHER RIVETED, BOLTED, OR WELDED. SEE DETAILS THIS PAGE.

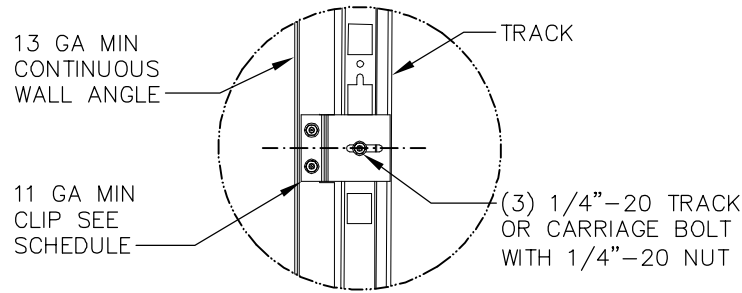

TYPICAL CLIP BOLTING DETAIL

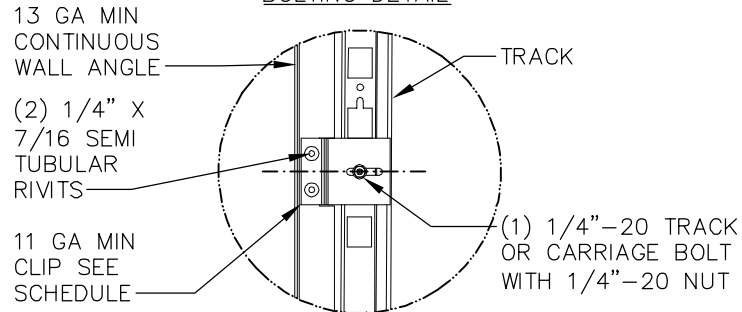

TYPICAL CLIP RIVETING DETAIL

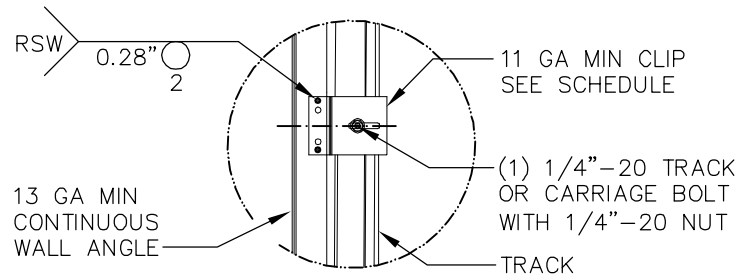

TYPICAL CLIP WELDING DETAIL

DESIGN PRESSURE CHART	
MAX DOOR WIDTH	MAX PSF
9'-0"	+46.0 PSF/-52.0 PSF
16'-0"	+46.0 PSF/-52.0 PSF
18'-0"	+46.0 PSF/-52.0 PSF

JOHN E. SCATES, P.E.  
3121 FAIRGATE DR.  
CARROLLTON, TX  
FL PE 51737  
TX PE 56308 / F-2203

PROFESSIONAL ENGINEER'S SEAL PROVIDED ONLY FOR VERIFICATION OF WINDLOAD CONSTRUCTION DETAILS.

TRACK SUPPLEMENT CHART



3395 ADDISON DRIVE  
PENSACOLA, FLORIDA 32514  
(850) 474-9890

REVISIONS		
P2	2 INCH TRACK-CLIPS-TEXAS WALL ANGLE 12 FOOT UPDATED	BPJ 6/11/03
P3	UPDATED FORMAT. INCREASED ALLOWABLE PRESSURES TO +46.00/-52.00 PSF FOR ALL DOOR WIDTHS. CHANGED "TEXAS WALL ANGLE" TO "CONTINUOUS WALL ANGLE". ADDED SUBSTRATE MOUNTING DETAIL, CHANGED TO TITEN HD ANCHORS	GRT 4/2/07
P4	CHANGED FORMAT. ADDED MODELS 9800 AND 8024 WITH OVERLAY TO TRACK CLIP SCHEDULE.	GRT 8/21/07
P5	UPDATED MODELS LISTED IN CHARTS. UPDATED SPLICE & CLIP SCHEDULES.	DLP 9/06/07
P6	UPDATE MOUNTING DETAIL DRAWINGS.	GRT 10/05/07
P7	UPDATED CHARTS TO ELIMINATE THE USE OF THE #8 CLIP (REPLACED WITH #9 ACROSS THE BOARD).	DLP 10/24/07
P8	UPDATED STEEL MOUNTING DETAIL	MRB 04/11/08
P9	EXPANDED 1-1/2" TO 1-3/8" DOOR THICKNESS CHART UP TO 14' HIGH.	GRT 12/11/08
P10	UPDATED TITLE BLOCK	GRT 6/2/10
P11	UPDATED TITLE BLOCK. REMOVED CHART.	GRT 11/15/13

	DATE	NAME
DRAWN	8/21/07	GRT
CHECKED	8/21/07	MRB
SHEET 1 OF 2		
DRAWING PART NO.	307494	REV. P11

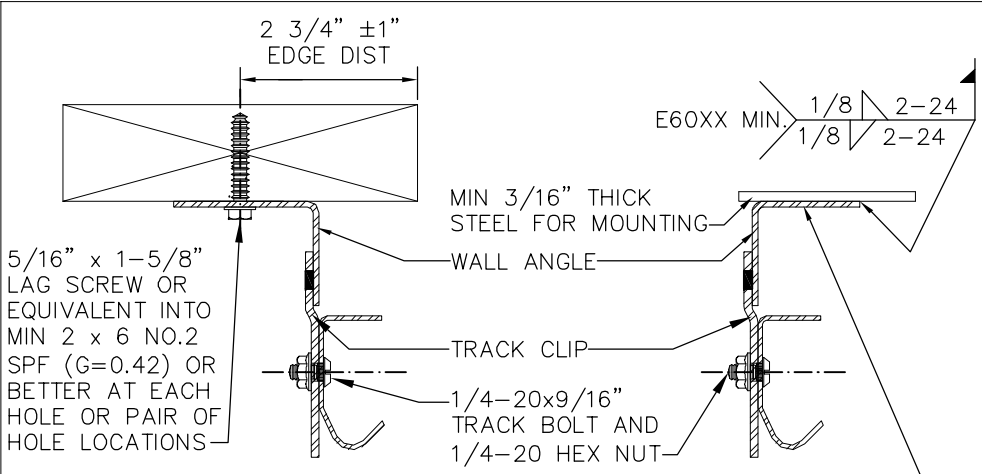

5/16" x 1-5/8" LAG SCREW OR EQUIVALENT INTO MIN 2 x 6 NO.2 SPF (G=0.42) OR BETTER AT EACH HOLE OR PAIR OF HOLE LOCATIONS

MIN 3/16" THICK STEEL FOR MOUNTING

WALL ANGLE

TRACK CLIP

1/4-20x9/16" TRACK BOLT AND 1/4-20 HEX NUT

E60XX MIN. 1/8 2-24 1/8 2-24

MOUNTING TO WOOD JAMB DETAIL

MOUNTING TO STEEL DETAIL

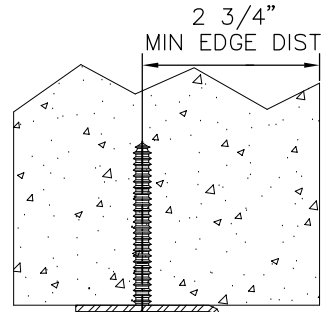

OPTIONAL: WALL ANGLE MAY BE ATTACHED TO SUPPORTING STEEL WITH MIN. (1) 1/4-20x7/8" SELF DRILLING SCREW WITH 1" O.D. WASHER AT EACH HOLE OR PAIR OF HOLE LOCATIONS IN LIEU OF WELDING

3/8" SIMPSON TITEN HD, 2-3/4" MIN EMBED INTO MIN 2000 PSI CONCRETE AT EACH HOLE OR PAIR OF HOLE LOCATIONS

WALL ANGLE

1/4-20x9/16" TRACK BOLT AND 1/4-20 HEX NUT

TRACK CLIP

CONCRETE MOUNTING DETAIL

PROFESSIONAL ENGINEER'S SEAL PROVIDED ONLY FOR VERIFICATION OF WINDLOAD CONSTRUCTION DETAILS.

REVISIONS

- P2 2 INCH TRACK-CLIPS-TEXAS WALL ANGLE 12 FOOT UPDATED BPJ 6/11/03
- P3 UPDATED FORMAT. INCREASED ALLOWABLE PRESSURES TO +46.00/-52.00 PSF FOR ALL DOOR WIDTHS. CHANGED "TEXAS WALL ANGLE" TO "CONTINUOUS WALL ANGLE". ADDED SUBSTRATE MOUNTING DETAIL, CHANGED TO TITEN HD ANCHORS GRT 4/2/07
- P4 CHANGED FORMAT. ADDED MODELS 9800 AND 8024 WITH OVERLAY TO TRACK CLIP SCHEDULE. GRT 8/21/07
- P5 UPDATED MODELS LISTED IN CHARTS. UPDATED SPLICE & CLIP SCHEDULES. DLP 9/06/07
- P6 UPDATE MOUNTING DETAIL DRAWINGS. GRT 10/05/07
- P7 UPDATED CHARTS TO ELIMINATE THE USE OF THE #8 CLIP (REPLACED WITH #9 ACROSS THE BOARD). DLP 10/24/07
- P8 UPDATED STEEL MOUNTING DETAIL MRB 04/11/08
- P9 EXPANDED 1-1/2" TO 1-3/8" DOOR THICKNESS CHART UP TO 14' HIGH. GRT 12/11/08
- P10 ADDED MODEL 8700. UPDATED TITLE BLOCK GRT 6/2/10
- P11 UPDATED TITLE BLOCK. REMOVED CHART. GRT 11/15/13



3395 ADDISON DRIVE  
PENSACOLA, FLORIDA 32514  
(850) 474-9890

	DATE	NAME
DRAWN	8/21/07	GRT
CHECKED	8/21/07	MRB
SHEET 2 OF 2		
DRAWING PART NO.	307494	REV. P11

TRACK SUPPLEMENT CHART