

NOTES:

1. NON-IMPACT RESISTANT GLAZING OPTION - 1/8" MINIMUM DSB GLAZING IN MOLDED FRAMES SCREWED TOGETHER WITH A MINIMUM OF (10) #8x1" SCREWS INSTALLED IN TOP OR INTERMEDIATE SECTION (WITH OR WITHOUT DECORATIVE INSERTS) MEETS UNIFORM STATIC WIND PRESSURES SHOWN ON THIS DRAWING. GLAZING SHALL HAVE A MAXIMUM HEIGHT OF 10.69" AND A MAXIMUM LENGTH OF 16.94". GLAZING IS NOT IMPACT RESISTANT AND DOES NOT MEET THE REQUIREMENTS FOR WIND-BORNE DEBRIS REGIONS.
2. IMPACT RESISTANT GLAZING OPTION- IMPACT RESISTANT GLAZING SYSTEM MAY BE INSTALLED IN TOP OR INTERMEDIATE SECTION (WITH OR WITHOUT DECORATIVE INSERTS). GLAZING SHALL BE 1/4" POLYCARBONATE. MAXIMUM GLAZING DIMENSIONS SHALL BE 11" X 17" CUTOUT, FASTENED WITH #8 X 1" SMS: 3X ALONG THE HORIZONTAL AND 2X ALONG THE VERTICAL. SEE DETAIL E ON SHEET 2 FOR ASSEMBLY DETAILS.
3. VINYL OR WOOD DOOR STOP NAILED A MAXIMUM OF 6" O.C. MUST OVERLAP TOP AND BOTH ENDS OF PANELS MINIMUM 7/16" TO MEET NEGATIVE PRESSURES.
4. KEY LOCK, SLIDE LOCKS, OR OPERATOR REQUIRED.
5. LOUVER OPTION - .032" MINIMUM LOUVERS IN MOLDED FRAMES SCREWED TOGETHER WITH A MINIMUM OF (10) #8x1" SCREWS INSTALLED IN THE BOTTOM SECTION. LOUVERS ARE NOT IMPACT RESISTANT AND DO NOT MEET THE REQUIREMENTS FOR WIND-BORNE DEBRIS REGIONS.
6. SECTION STEEL TO HAVE A MINIMUM 25 GA THICKNESS.
7. THE DESIGN OF THE SUPPORTING STRUCTURAL ELEMENTS SHALL BE THE RESPONSIBILITY OF THE PROFESSIONAL OF RECORD FOR THE BUILDING OR STRUCTURE AND IN ACCORDANCE WITH CURRENT BUILDING CODES FOR THE LOADS LISTED ON THIS DRAWING.
8. DOOR JAMB TO BE MINIMUM 2x6, STRUCTURAL GRADE SOUTHERN PINE. REFER TO JAMB CONNECTION SUPPLEMENT FOR ATTACHMENT TO SUPPORTING STRUCTURE.
9. FOR LOW HEAD ROOM LIFT CONDITIONS, TOP BRACKET SHALL BE (2) 13 GA LHR 7/4 TOP BRACKETS WITH A MINIMUM OF (2) 1/4-14x7/8" SELF DRILLING CRIMP TITE SCREWS IN EACH IN LIEU OF THE BRACKET SHOWN ON THIS DRAWING. U-BAR ON TOP SECTION SHALL BE INSTALLED ON TOP OF LHR TOP BRACKETS. SEE DETAIL F.
10. DOORS ARE DESIGNED AND MANUFACTURED TO COMPLY WITH REGULATIONS PER BUILDING CODES: 2018 IRC AND 2018 IBC.

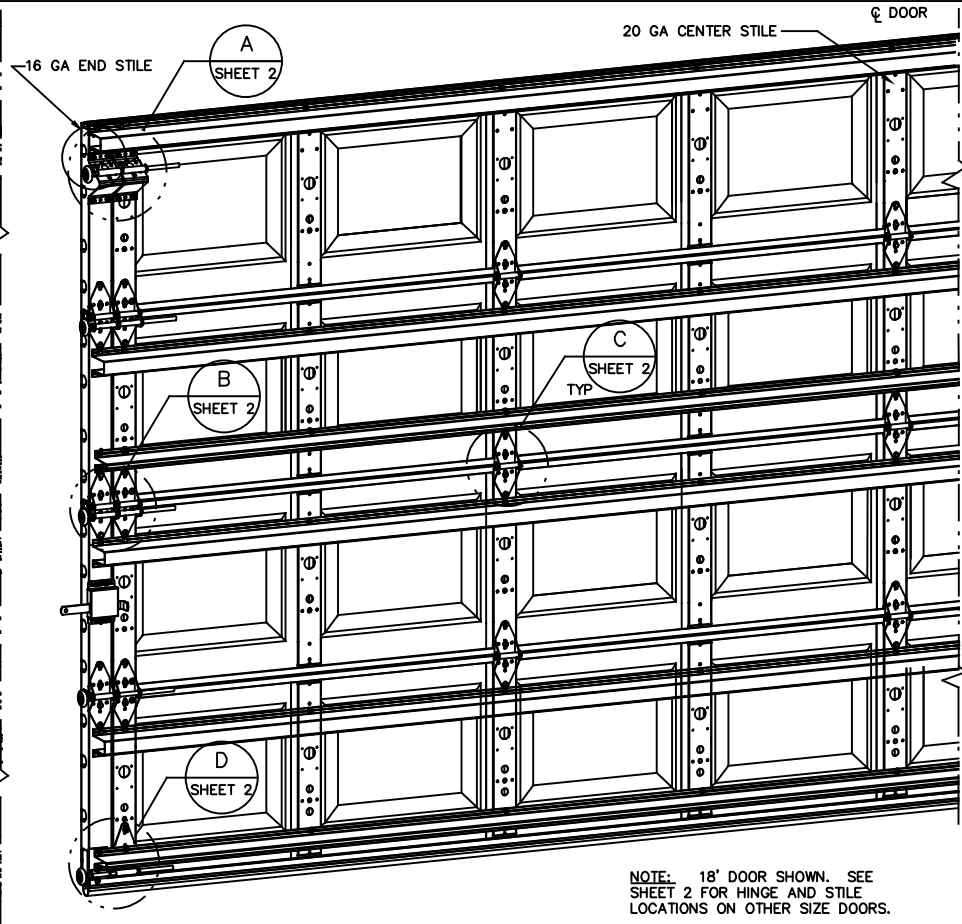
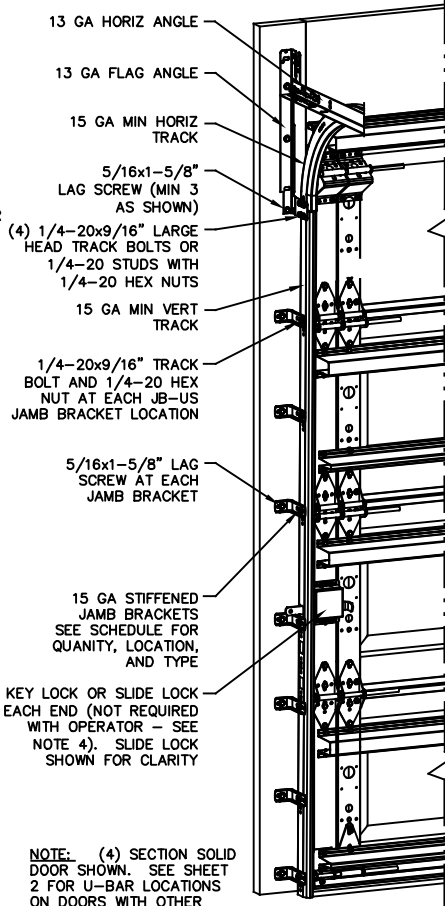

REVISIONS
PO DRAWING CREATED JQ 3/18/20
REV A: PER PCR 32537, ADD NOTE 10: IBC/IRC REGS. JQ 11/30/20

NOTE: (4) SECTION SOLID DOOR SHOWN. SEE SHEET 2 FOR U-BAR LOCATIONS ON DOORS WITH OTHER SECTION QUANTITIES AND SEE NOTES 1 AND 2 THIS SHEET FOR GLAZING OPTIONS.

NOTE: 18' DOOR SHOWN. SEE SHEET 2 FOR HINGE AND STILE LOCATIONS ON OTHER SIZE DOORS.

SUPERIMPOSED DESIGN PRESSURE LOADS ON SUPPORTING STRUCTURE

DOOR WIDTH	DOOR HEIGHT	UNIFORM LOAD EACH JAMB (PLF)
17'-0"	ALL	+292.4/-325.6
18'-0"	ALL	+309.6/-344.7

JAMB BRACKET SCHEDULE

DOOR HEIGHT	NO. OF SECTIONS	NO. OF JAMB BRACKETS (EACH JAMB)	LOCATION OF CENTERLINE OF JAMB BRACKETS MEASURED FROM BOTTOM OF TRACK (ALL DIMENSIONS ± 2")
6'-6"	4	7	2" (JB-US), 10" (JB-US), 21-3/4" (JB-US), 29-3/4" (JB-US), 39" (JB-US), 48" (JB-US), 57-1/4" (JB-US)
7'-0"	4	7	2" (JB-US), 10" (JB-US), 21-3/4" (JB-US), 29-3/4" (JB-US), 42" (JB-US), 52-1/2" (JB-US), 63-1/4" (JB-US)
7'-6"	5	9	2" (JB-US), 10" (JB-US), 18-3/4" (JB-US), 26-3/4" (JB-US), 36" (JB-US), 45" (JB-US), 54-1/4" (JB-US), 63" (JB-US), 74-1/2" (JB-US)
8'-0"	5	9	2" (JB-US), 10" (JB-US), 21-3/4" (JB-US), 29-3/4" (JB-US), 39" (JB-US), 48" (JB-US), 57-1/2" (JB-US), 66" (JB-US), 75-1/2" (JB-US)
> 8'-0"			SEE NOTE BELOW

NOTE: (JB-US) FOLLOWING DIMENSION DENOTES SLOTTED JAMB BRACKET ATTACHED TO TRACK WITH 1/4-20x9/16" TRACK BOLT AND NUT AS SHOWN ABOVE.
ALL DOORS GREATER THAN 8' IN HEIGHT REQUIRE USE OF CONTINUOUS WALL ANGLE. SEE SUPPLEMENT TRACK CHART FOR DETAILS.

JOHN E. SCATES, PE
2560 KING ARTHUR #124-54
LEWISVILLE, TX 75056
FL PE 51737
TX PE 56308/F2203
PROFESSIONAL ENGINEER'S SEAL PROVIDED ONLY FOR VERIFICATION OF WINDLOAD CONSTRUCTION DETAILS.



A DIVISION OF OVERHEAD DOOR CORP
3395 ADDISON DRIVE
PENSACOLA, FLORIDA 32514
(850) 474-9890

STATIC PRESSURE RATINGS		APPROVED SIZES	SCALE: N.T.S.	SIZE: A
DESIGN (PSF):	+34.40/-38.30	MAX WIDTH: 18'-0"	DATE	NAME
TEST (PSF):	+51.60/-57.45	MAX HEIGHT: 14'-0"	DRAWN 11/13/19	JQ
IMPACT/CYCLIC RATED (YES/NO):	YES	MAX SECTION HEIGHT: 21"	CHECKED 11/13/19	DK
MODELS 8000/8100/8200			SHEET 1 OF 2	
WINDLOAD SPECIFICATION OPTION CODE 1147			DRAWING PART NO. 365187	REV. A

REVISIONS

PO DRAWING CREATED
JQ 3/18/20
REV A: PER PCR 32537,
ADD NOTE 10: IBC/IRC
REGS. JQ 11/30/20

13 GA ROLLER SLIDE ATTACHED TO BRACKET WITH 5/16-18 BOLT & NUT IN CENTER SLOT AND 1/4-20x9/16" TRACK BOLT & 1/4-20 HEX NUT THROUGH ANY TWO ALIGNING HOLES

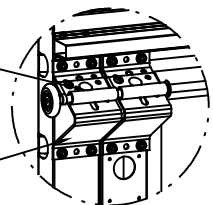

DETAIL A

(2) 13 GA COMMERCIAL 'A' FRAME TOP BRACKETS EACH ATTACHED WITH (4) 1/4-14x7/8" SELF DRILLING CRIMPITTE SCREWS

ADD (2) 1/4-14x7/8" SELF DRILLING CRIMPITTE SCREWS (INSIDE OF EACH INSIDE END HINGE)

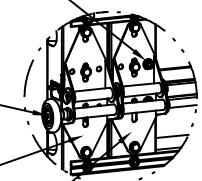

DETAIL B

2" STEEL ROLLER WITH 9" GRADE 1144 OR EQUIVALENT STEM AND 7/16" PUSHNUT AT EACH ROLLER LOCATION. 1/4" MAX BETWEEN PUSHNUT AND BRACKET OR HINGE

WIDE BODY END HINGE ATTACHED WITH (4) 1/4-14x5/8" SELF TAPPING SCREWS

WIDE BODY END HINGE ATTACHED WITH (4) 1/4-14x5/8" SELF TAPPING SCREWS

DOUBLE END HINGES
#1 HINGE IS 14 GA
#2 HINGE IS 13 GA
#3 HINGE IS 13 GA

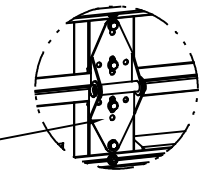

DETAIL C

14 GA WIDE BODY INTERMEDIATE HINGE ATTACHED WITH (4) 1/4-14x5/8" SELF TAPPING SCREWS

12 GA EXTENSION BRACKET ATTACHED WITH (3) 1/4-14x7/8" SELF DRILLING CRIMPITTE SCREWS (2 THROUGH STRUT AND BRACKET)

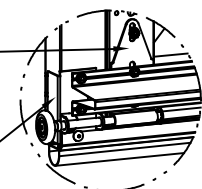

DETAIL D

14 GA BOTTOM BRACKET ATTACHED WITH (2) 1/4-14x7/8" SELF DRILLING CRIMPITTE SCREWS THROUGH STRUT AND BOTTOM BRACKET AND (1) 1/4-14x5/8" SELF DRILLING RED SCREW

CENTER STILE & INTERMEDIATE HINGE LOCATIONS

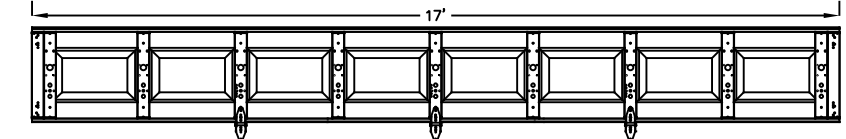
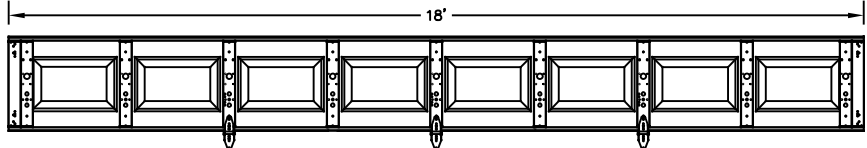

U-BAR LOCATIONS

(8) SECTION DOORS WITH
4" 16 GA 80 KSI U-BARS
(4) 3" 18 GA 80 KSI U-BARS
LOCATED AS SHOWN

(7) SECTION DOORS WITH
(7) 4" 16 GA 80 KSI U-BARS
(4) 3" 18 GA 80 KSI U-BARS
LOCATED AS SHOWN

(6) SECTION DOORS WITH
(6) 4" 16 GA 80 KSI U-BARS
(3) 3" 18 GA 80 KSI U-BARS
LOCATED AS SHOWN

(5) SECTION DOORS WITH
(5) 4" 16 GA 80 KSI U-BARS
(3) 3" 18 GA 80 KSI U-BARS
LOCATED AS SHOWN

(4) SECTION DOORS WITH
(4) 4" 16 GA 80 KSI U-BARS
(2) 3" 18 GA 80 KSI U-BARS
LOCATED AS SHOWN

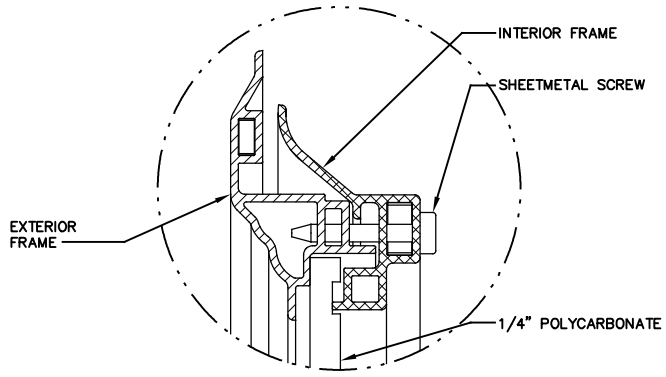
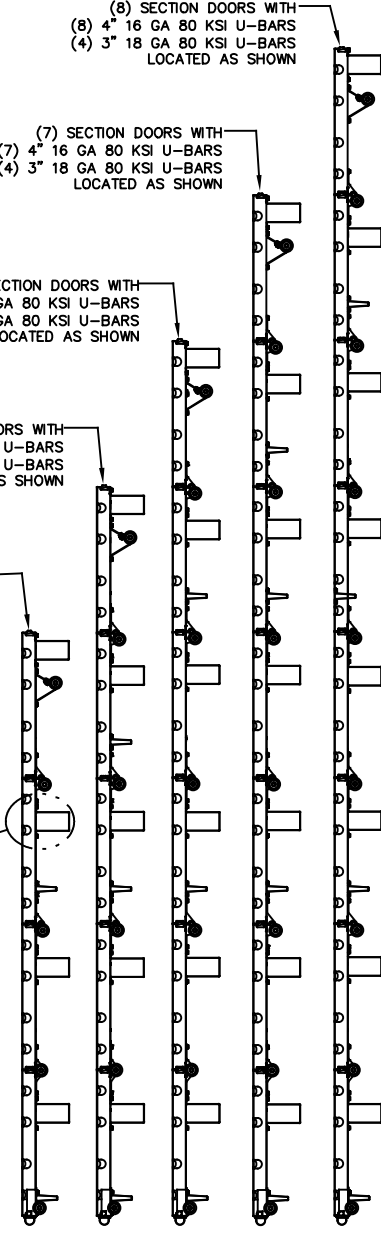

IMPACT WINDOW / ALUMINUM FRAME WITH GROOVED POLYCARBONATE

DETAIL E

13 GA ADJUSTABLE TOP FIXTURE

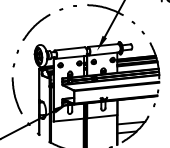

LOW HEADROOM TRACK
DETAIL F

PLACE 4" U-BAR OVER LOW HEADROOM BRACKET ATTACH THRU END STILE AND CENTER STILE AT EACH END WITH (4) 1/4-14x7/8" SELF DRILLING CRIMPITTE SCREWS.

ATTACH U-BAR WITH (2) 1/4-14x7/8" SELF DRILLING CRIMPITTE SCREWS AT EACH STILE LOCATION, TYP.

JOHN E. SCATES, PE
2560 KING ARTHUR #124-54
LEWISVILLE, TX 75056
FL PE 51737
TX PE 56308/F2203

PROFESSIONAL ENGINEER'S SEAL PROVIDED ONLY FOR VERIFICATION OF WINDLOAD CONSTRUCTION DETAILS.

Wayne Dalton
GARAGE DOORS™

A DIVISION OF OVERHEAD DOOR CORP.
3395 ADDISON DRIVE
PENSACOLA, FLORIDA 32514
(850) 474-9890

STATIC PRESSURE RATINGS		APPROVED SIZES		SCALE: N.T.S.	SIZE: A
DESIGN (PSF):	+34.40/-38.30	MAX WIDTH:	18'-0"	DATE	NAME
TEST (PSF):	+51.60/-57.45	MAX HEIGHT:	14'-0"	DRAWN	JQ
IMPACT/CYCLIC RATED (YES/NO):	YES	MAX SECTION HEIGHT:	21"	CHECKED	DK
MODELS 8000/8100/8200				SHEET 2 OF 2	
WINDLOAD SPECIFICATION OPTION CODE 1147				DRAWING PART NO.	REV.
				365187	A