

- NOTES:
- NON-IMPACT GLAZED OPTIONS IN MOLDED FRAMES (DETAIL E):
 - .090 MIN SSB MAX GLAZING. DSB ANNEALED & TEMPERED GLASS ALLOWED.
 - SHORT LITES:
 - CLEAR OPENING SIZE:
 - MAX WD=15.72; MAX HT=12.72
 - (10) MIN QTY SCREWS #8X1-(3) ALONG HORIZONTAL LEG AND (2) ALONG VERTICAL LEG.
 - LONG LITES:
 - CLEAR OPENING SIZE:
 - MAX WD=39.92; MAX HT=12.72
 - (14) MIN QTY SCREWS #8X1-(3) ALONG HORIZONTAL LEG AND (2) ALONG VERTICAL LEG.
 - DECORATIVE TRIM INSERTS ALLOWED.
 - (1) GLAZED SECTION ALLOWED IN 3RD SECTION OR HIGHER.
 - VINYL OR WOOD DOOR STOP NAILED A MAXIMUM OF 6" O.C. MUST OVERLAP TOP AND BOTH ENDS OF PANELS MINIMUM 7/16" TO MEET NEGATIVE PRESSURES.
 - KEY LOCK, SLIDE LOCKS, OR OPERATOR REQUIRED.
 - SECTION SHALL BE CONSTRUCTED WITH FOAMED IN PLACE POLYURETHANE FOAM INSULATION CHEMICALLY BONDED TO 30 GA MINIMUM FACER STEEL AND A POLYLAMINATE OR 32 GA STEEL BACKER. SECTION THICKNESS AT END CAP IS 1.2".
 - THE DESIGN OF THE SUPPORTING STRUCTURAL ELEMENTS SHALL BE THE RESPONSIBILITY OF THE PROFESSIONAL OF RECORD FOR THE BUILDING OR STRUCTURE AND IN ACCORDANCE WITH CURRENT BUILDING CODES FOR THE LOADS LISTED ON THIS DRAWING.
 - DOOR JAMB TO BE MINIMUM 2x6 SOUTHERN PINE LUMBER. REFER TO JAMB CONNECTION SUPPLEMENT FOR ATTACHMENT TO SUPPORTING STRUCTURE.
 - LOUVER OPTION (DETAIL F) - .040" MINIMUM LOUVERS IN MOLDED FRAMES SCREWED TOGETHER WITH A MINIMUM OF (12) #8x5/8" SCREWS INSTALLED IN THE BOTTOM SECTION ((3) ALONG EACH HORIZONTAL LEG AND (3) ALONG EACH VERTICAL LEG) WITH LOUVER OPENING BEING 18 1/8" X 11 1/4". LOUVERS ARE NOT IMPACT RESISTANT AND DO NOT MEET THE REQUIREMENTS FOR WIND-BORNE DEBRIS REGIONS. LOUVERED SECTION REQUIRES OPERATOR STILE TO BE FACTORY INSTALLED AT THE CENTERLINE OF THE DOOR.
 - SEE SHEET 3 FOR FASTENER NOTES.
 - THE TERMS STRUT AND U-BAR MAY BE USED INTERCHANGEABLY.
 - SEE SHEET 3 FOR STRUT ATTACHMENT INSTRUCTIONS.
 - COMPLIES WITH THE REQUIREMENTS OF IBC/IRC 2018.

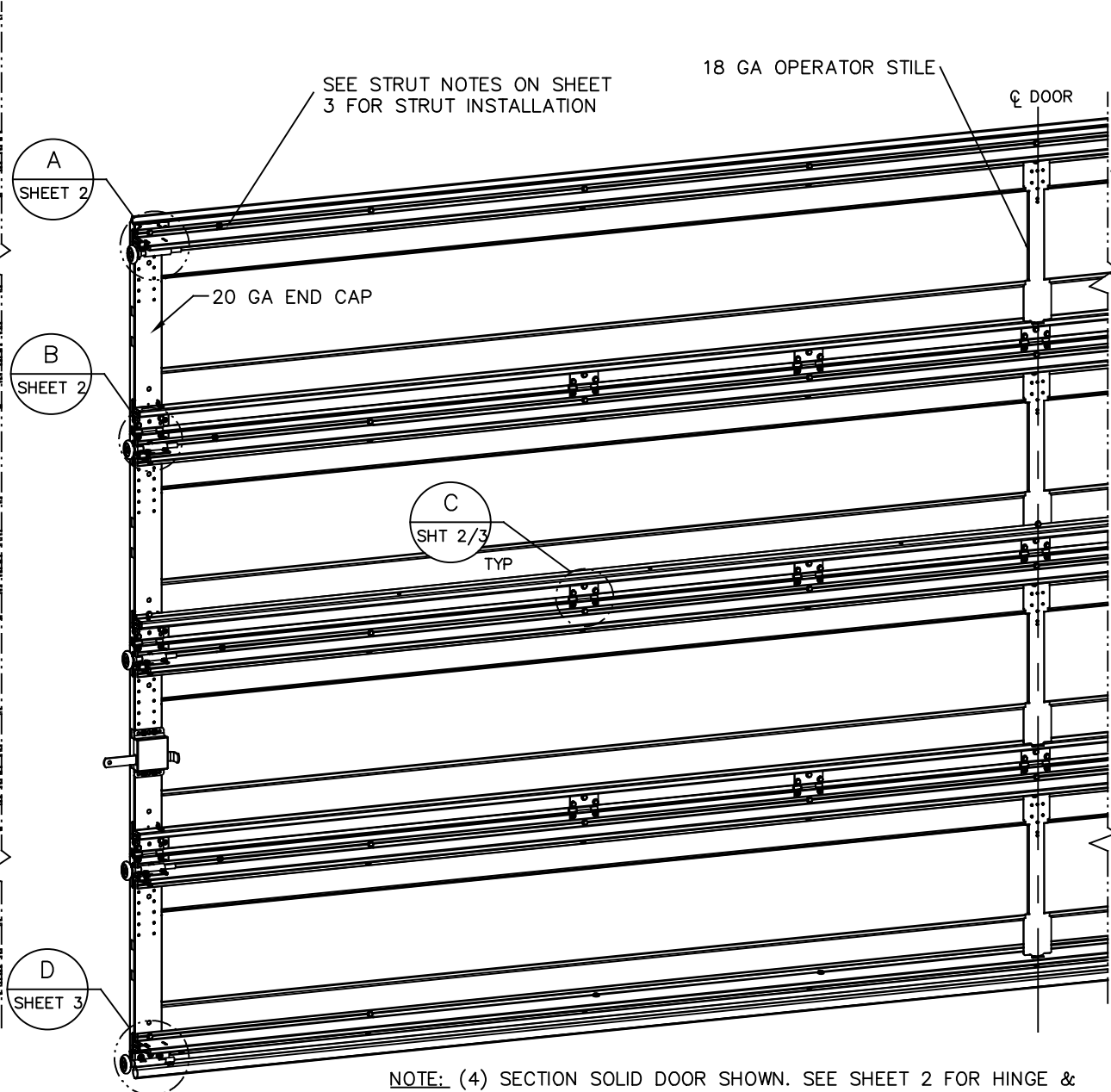
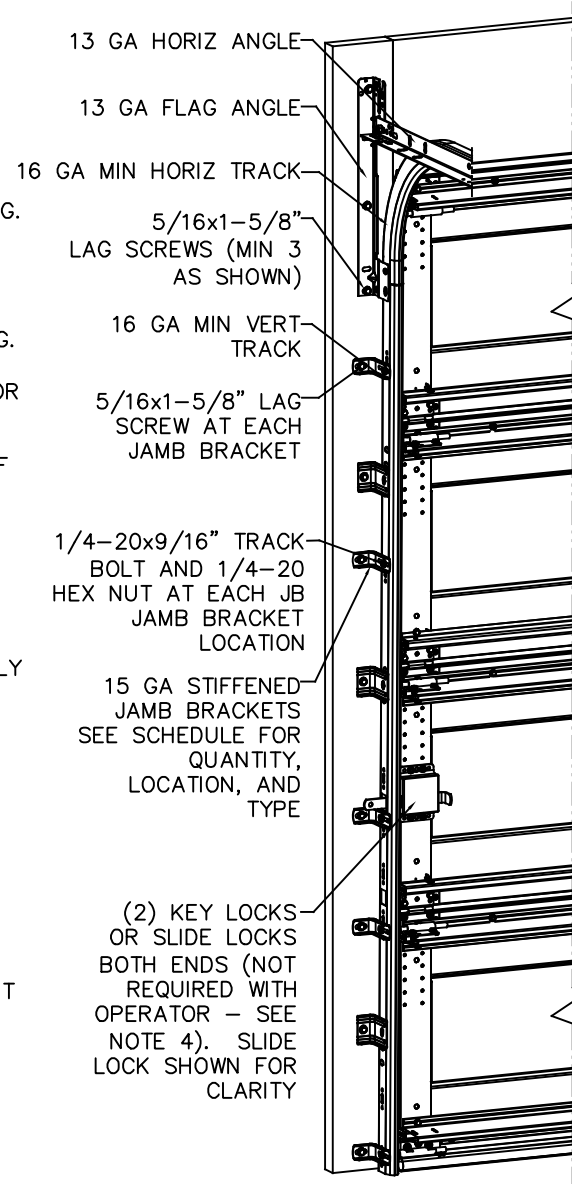

NOTE: (4) SECTION SOLID DOOR SHOWN. SEE SHEET 2 FOR HINGE & OPERATOR STILE QUANTITIES. SEE SHEET 3 FOR STRUT QUANTITY & LOCATIONS. SEE NOTES 1 & 2 ON THIS SHEET FOR GLAZING OPTIONS.

SUPERIMPOSED DESIGN PRESSURE LOADS ON SUPPORTING STRUCTURE		
MAX DOOR WIDTH	DOOR HEIGHT	UNIFORM LOAD EACH JAMB (PLF) +23.00/-25.00
16'-0"	ALL	+184.0/-200.0
14'-0"	ALL	+161.0/-175.0
12'-0"	ALL	+138.0/-150.0
10'-0"	ALL	+115.0/-125.0

JOHN E. SCATES, PE
2560 KING ARTHUR BLVD #124
LEWISVILLE, TX 75056
FL PE 51737
TX PE 56308 / F2203
PROFESSIONAL ENGINEER SEAL PROVIDED ONLY FOR VERIFICATION OF WINDLOAD CONSTRUCTION DETAILS.

STANDARD LIFT AND LOW HEADROOM JAMB BRACKET SCHEDULE				
DOOR HEIGHT	NO. OF SECTIONS	NO. OF JAMB BRACKETS (EACH JAMB)	TRACK TYPE	LOCATION OF CENTERLINE OF JAMB BRACKETS MEASURED FROM BOTTOM OF TRACK (ALL DIMENSIONS ± 2")
7'-0"	4	6	QI	2" (JB), 13" (QI), 25-1/2" (JB), 34" (JB), 45-1/4" (QI), 63" (JB)
7'-0"	4	6	FAT	2" (JB), 10" (JB), 21-3/4" (JB), 29-3/4" (JB), 42" (JB), 63-1/4" (JB)
8'-0"	4 OR 5	8	QI	2" (JB), 13" (QI), 23" (JB), 34" (JB), 47-1/4" (QI), 58" (JB), 67" (QI), 75" (JB)
8'-0"	4 OR 5	8	FAT	2" (JB), 10" (JB), 21-3/4" (JB), 29-3/4" (JB), 48" (JB), 57-1/4" (JB), 66" (JB), 75-1/2" (JB)
> 8'-0"/HIGH LIFT/ROOF PITCH				SEE NOTE BELOW

- TRACK NOTES:
- (JB) FOLLOWING DIMENSION DENOTES SLOTTED JAMB BRACKET ATTACHED TO TRACK WITH 1/4-20x9/16" TRACK BOLT AND NUT.
 - (QI) FOLLOWING DIMENSION DENOTES QUICK INSTALL JAMB BRACKET INSTALLED IN BUTTERFLY SLOT. NO ADDITIONAL HARDWARE NEEDED TO ATTACH TO TRACK.
 - ALL DOORS WITH HIGH LIFT, ROOF PITCH, AND/OR GREATER THAN 8' IN HEIGHT REQUIRE USE OF CONTINUOUS WALL ANGLE. SEE SUPPLEMENT TRACK CHART FOR DETAILS.

Wayne Dalton
GARAGE DOORS™
A DIVISION OF OVERHEAD DOOR CORP
3395 ADDISON DRIVE
PENSACOLA, FLORIDA 32514
(850) 474-9890

STATIC PRESSURE RATINGS		APPROVED SIZES		SCALE: N.T.S.	SIZE: C
DESIGN (PSF):	+23.00/-25.00	MAX WIDTH:	16'-0"	DATE	NAME
TEST (PSF):	+34.50/-37.50	MAX HEIGHT:	12'-0"	DRAWN	1/27/20
IMPACT/CYCLIC RATED (YES/NO):	NO	MAX SECTION HEIGHT:	24"	CHECKED	5/19/21
MODELS 5120/9100/9405/9605/TS100/TS120				SHEET 1 OF 3	
WINDLOAD SPECIFICATION OPTION CODE 0650				DRAWING PART NO.	REV.
				411636	C

REVISIONS
PO NEW WL CODE. PER NPD0053 CSM 1/27/20
REV A: PER PCR 32421, ADD MDLS TS100/TS120; BL 17JUL20
REV B: PER PCR 32486, ADD NOTE 12: IBC/IRC REGS. BL 23SEP20
REV C: ADDED GLAZING VIEWS TLC 5/20/21

13 GA ADJUSTABLE TOP FIXTURE ATTACHED UNDER STRUT WITH (2) CRIMPTITE SCREWS

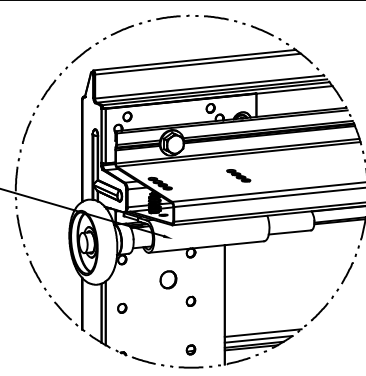

DETAIL A

13 GA ADJUSTABLE TOP FIXTURE ATTACHED THRU STRUT FLANGE INTO END CAP WITH (2) CRIMPTITE SCREWS

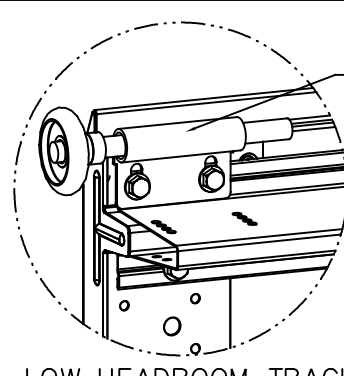

LOW HEADROOM TRACK DETAIL A

SECURE OPERATOR STILE WITH (4) #8 PIERCING SCREWS INTO INTEGRAL RIBS. (FACTORY INSTALLED) OR (2) CRIMPTITE SCREWS, ONE EACH END OF STILE.

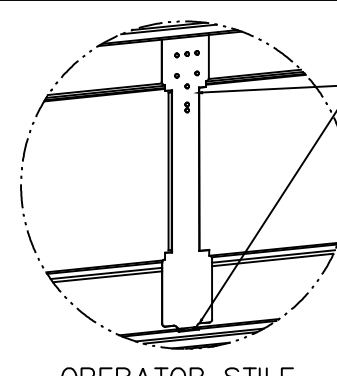

OPERATOR STILE ATTACHMENT

18 GA HINGE FACTORY ATTACHED WITH (4) CRIMPTITE SCREWS (6 SCREWS TOTAL)

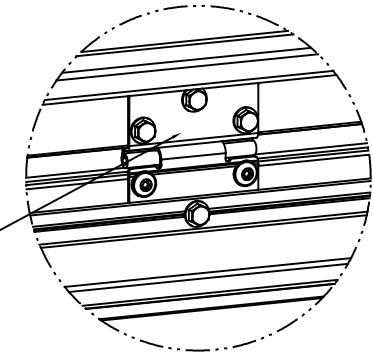

DETAIL C

13 GA ROLLER SLIDE ATTACHED ON TOP OF STRUT WITH (2) CRIMPTITE SCREWS

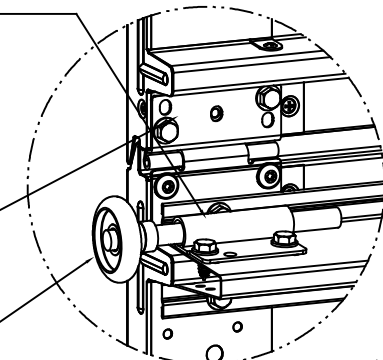

DETAIL B

15 GA HINGE FACTORY ATTACHED WITH (2) CRIMPTITE SCREWS (4 SCREWS TOTAL)

2" NYLON ROLLER, STORMGARD 5" STEM. OPTIONAL - 10/11-BALL BEARING ROLLER

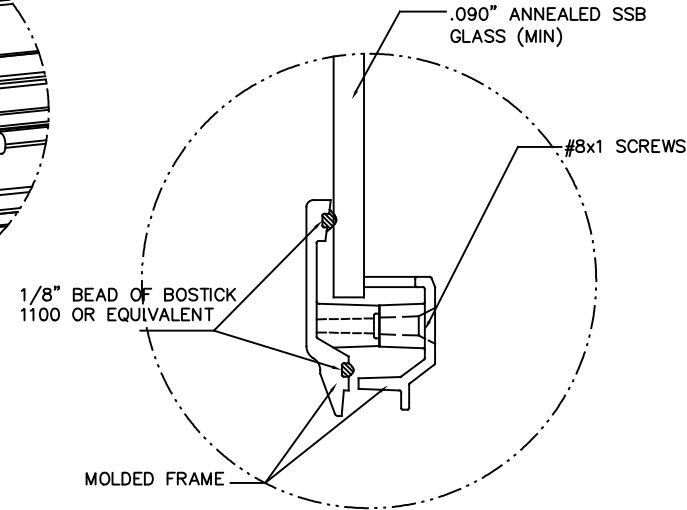

NON-IMPACT PLASTIC FRAME (STATIC RATED) DETAIL E

J-STRUT OVER RIB ENDS: SECURE WITH (1) CRIMPTITE SCREW THRU J-STRUT FLANGE LEG INTO ENDCAP, EACH END.
OPERATOR STILE: SECURE WITH (1) CRIMPTITE SCREW THRU J-STRUT FLANGE INTO OPERATOR STILE.
ALONG STRUT: SECURE WITH (2) #8 PIERCING SCREWS FROM J-STRUT LEG INTO RIB IN PRE-DRILLED HOLES @ 27" ± 4" O.C. (FACTORY INSTALLED)

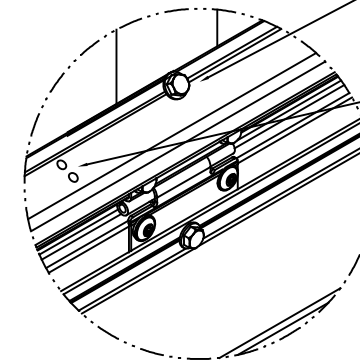

J-STRUT ATTACHMENT

12 GA BOTTOM BRACKET FACTORY ATTACHED WITH (3) CRIMPTITE SCREWS TOTAL

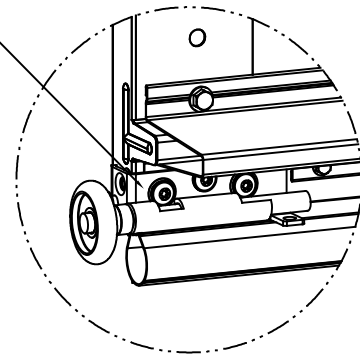

DETAIL D

SECTION QUANTITIES

Door Width	CRP / FLUSH				RANCH				SONOMA				SONOMA RANCH				
	STAMPS /SHORT LITES	CTR HNG	OP STILES: SOLID	OP STILES: GLAZED	STAMPS /LONG LITES	CTR HNG	OP STILES: SOLID	OP STILES: GLAZED	STAMPS /SHORT LITES	LONG LITES	CTR HNG	OP STILES: SOLID	OP STILES: GLAZED	STAMPS /LONG LITES	CTR HNG	OP STILES: SOLID	OP STILES: GLAZED
10'-0"	5	3	2	2	2	3	1	1	4	2	3	1	1	2	3	1	1
11'-0"	5	3	2	2	2	3	1	1	4	2	3	1	1	2	3	1	1
12'-0"	6	3	1	1	3	3	2	2	6	3	3	2	2	3	3	2	2
13'-0"	7	5	2	2	3	5	2	2	6	3	5	2	2	3	5	2	2
14'-0"	7	5	2	2	3	5	2	2	6	3	5	2	2	3	5	2	2
15'-0"	7	5	2	2	4	5	1	1	8	4	5	1	1	3	5	2	2
16'-0"	8	5	1	1	4	5	1	1	8	4	5	1	1	4	5	1	1

Wayne Dalton
GARAGE DOORS
A DIVISION OF OVERHEAD DOOR CORP
3395 ADDISON DRIVE
PENSACOLA, FLORIDA 32514
(850) 474-9890

STATIC PRESSURE RATINGS		APPROVED SIZES		SCALE: N.T.S.	SIZE: C
DESIGN (PSF):	+23.00/-25.00	MAX WIDTH:	16'-0"	DATE	NAME
TEST (PSF):	+34.50/-37.50	MAX HEIGHT:	12'-0"	DRAWN	CSM
IMPACT/CYCLIC RATED (YES/NO):	NO	MAX SECTION HEIGHT:	24"	CHECKED	TC
MODELS 5120/9100/9405/9605/TS100/TS120				SHEET 2 OF 3	
WINDLOAD SPECIFICATION OPTION CODE 0650				DRAWING PART NO.	REV.
				411636	C

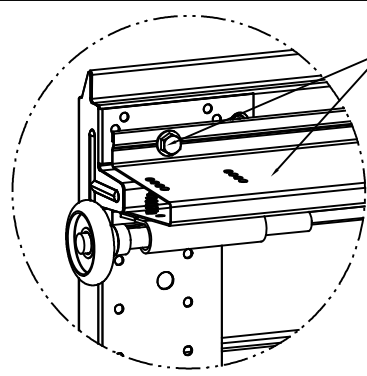

DETAIL A

3\"/>

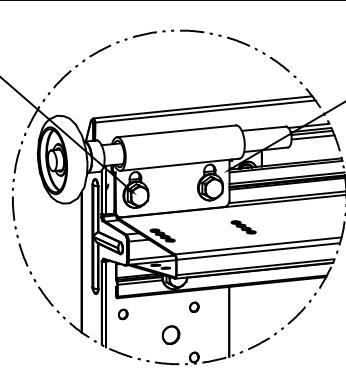

LOW HEADROOM TRACK
DETAIL A

SECURE THRU ROLLER SLIDES & STRUT FLANGE INTO END CAP & TOP RAIL WITH (2) CRIMPTITE SCREWS.

(6) SECTION DOORS:
(7) 3\"/>

3\"/>

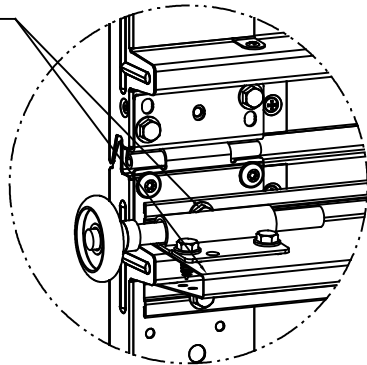

DETAIL B

3\"/>

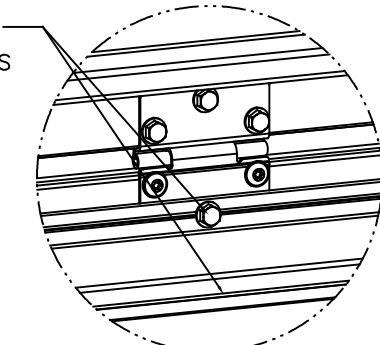

DETAIL C

3\"/>

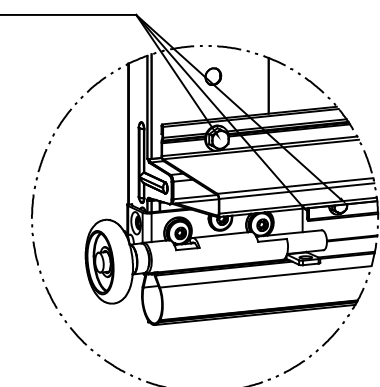

DETAIL D

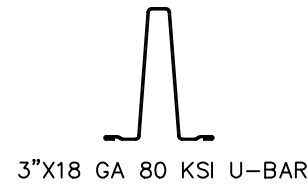

3\"/>

(5) SECTION DOORS:
(6) 3\"/>

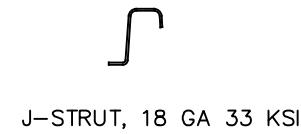

J-STRUT, 18 GA 33 KSI

(4) SECTION DOORS:
(5) 3\"/>

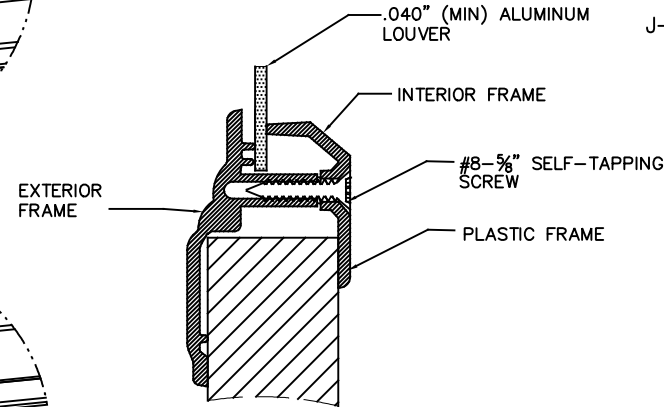

NON-IMPACT LOUVER
(STATIC RATED)
DETAIL F

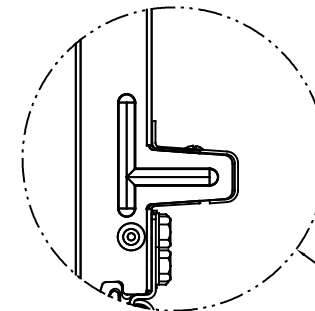

J-STRUT

FASTENER NOTES:

- STRUT SCREW TOTALS:**
 - 3\"/>
- FOR DW ≤ 12', USE 4 LESS CRIMPTITE SCREWS /STRUT
- "CRIMPTITE SCREW" = SCREW, 1/4-14 X 7/8" SELF-DRILLING, CRIMPTITE
- 1/4-20 SELF-TAPPING SCREWS MAY BE USED IN PLACE OF 1/4-14 SELF-DRILLING SCREWS FOR APPLICATIONS WITH PRE-PUNCHED HOLES OR WHEN PREDRILLING PILOT HOLES.

STRUTS &
J-STRUTS
INSTALLED OVER
INTEGRAL RIBS

<p>Wayne Dalton GARAGE DOORS A DIVISION OF OVERHEAD DOOR CORP 3395 ADDISON DRIVE PENSACOLA, FLORIDA 32514 (850) 474-9890</p>	STATIC PRESSURE RATINGS		APPROVED SIZES		SCALE: N.T.S.	SIZE: C	
	DESIGN (PSF):	+23.00/-25.00	MAX WIDTH:	16'-0"	DATE	NAME	
	TEST (PSF):	+34.50/-37.50	MAX HEIGHT:	12'-0"	DRAWN	1/27/20	CSM
	IMPACT/CYCLIC RATED (YES/NO):	NO	MAX SECTION HEIGHT:	24"	CHECKED	5/19/21	TC
MODELS 5120/9100/9405/9605/TS100/TS120					SHEET 3 OF 3		
WINDLOAD SPECIFICATION OPTION CODE 0650					DRAWING PART NO.	REV.	
					411636	C	