

NOTE: DOUBLE TRACK LOW HEADROOM, HI-LIFT TRACK, FOLLOW-THE-ROOF TRACK, AND VERTICAL LIFT TRACK ARE AVAILABLE OPTIONS. 3" TRACK ALSO AVAILABLE.

THE DESIGN OF THE SUPPORTING STRUCTURAL ELEMENTS IS THE RESPONSIBILITY OF THE BUILDING ENGINEER OR ARCHITECT OF RECORD.

MAX. 12'-2" WIDE X 18'-0" HIGH

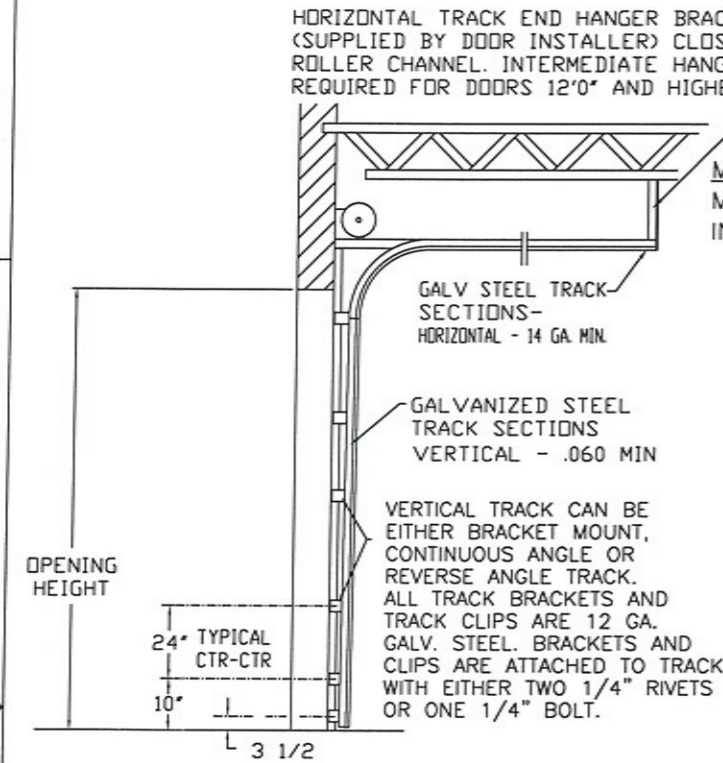

SIDE ELEVATION STANDARD-LIFT TRACK DETAILS

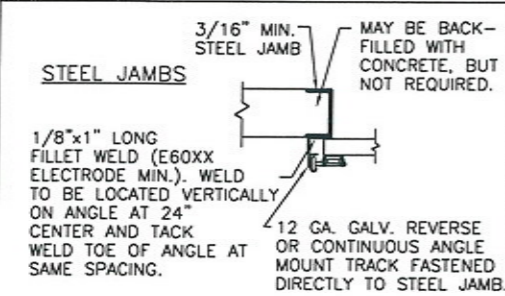

WOOD JAMB ON CONCRETE

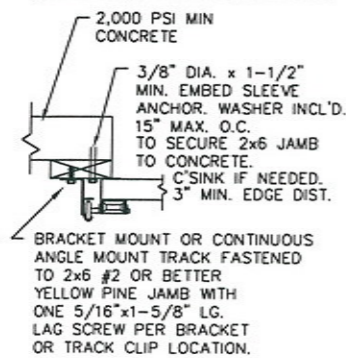

CONCRETE JAMBS

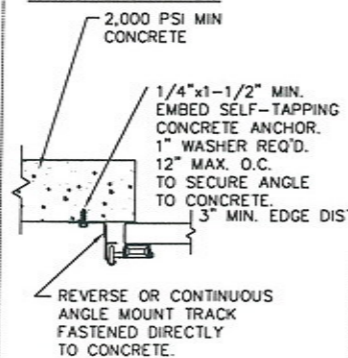

STEEL JAMBS

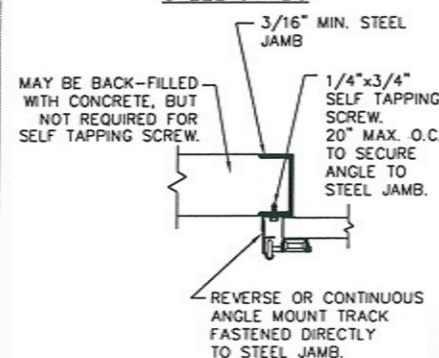

WOOD JAMBS

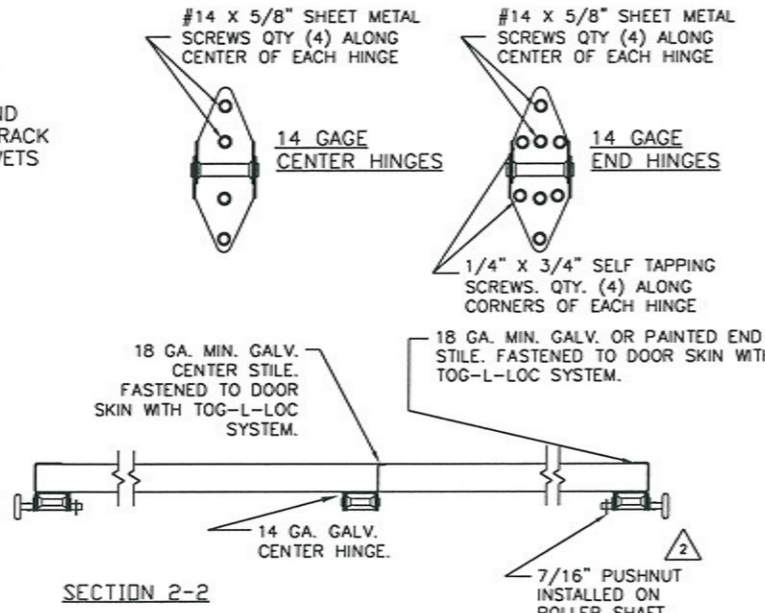
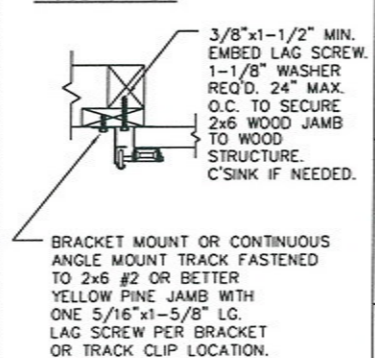

SECTION 2-2

ANCHOR NOTE: FIRST (BOTTOM) ANCHOR STARTING AT NO MORE THAN HALF OF THE MAXIMUM ON-CENTER DISTANCE. HIGHEST ANCHOR INSTALLED AT LEAST AS HIGH AS THE DOOR OPENING.

REVISIONS					
REV. NO.	ZONE:	DATE:	ECN NO.	APPVD:	DESCRIPTION
6	C3	06/2007	-	-	CLARIFIED U-BAR TABLE
7	-	11/2008	-	-	ADDED MPC AND WELDED JAMB ATTACH. DETAIL.
8	-	02/2012	-	-	UPDATED WINDCODE CHART
9	-	08/2012	-	-	REVISED FOR TDI
10	-	06/2013	-	-	REMOVED GLAZING OPTION.
11	-	08/2016	-	-	REMOVED WIND SPEED TABLE.

THE OPTIONAL GLAZING SHOWN ON THIS DRAWING MEETS THE WIND LOAD REQUIREMENTS OF THE FLORIDA BUILDING CODE OR INTERNATIONAL BUILDING CODE BUT DOES NOT MEET THE IMPACT RESISTANT REQUIREMENT FOR WINDBORNE DEBRIS REGIONS (REF. CHAPTER 16 FBC/IBC)

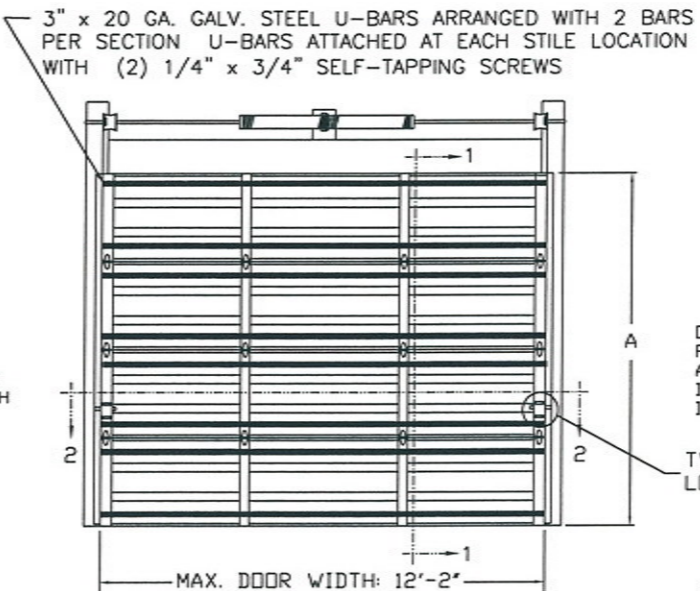
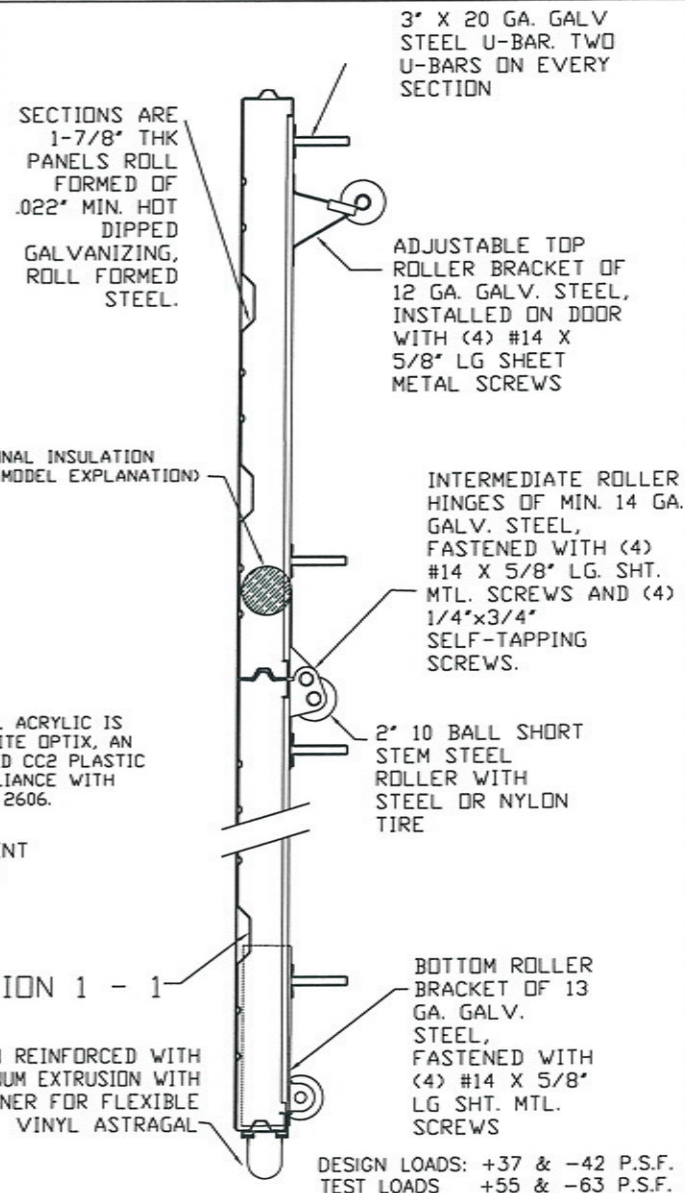

TABLE 1

DOOR HEIGHT	TOTAL U-BARS REQUIRED
4'3" TO 6'0"	6
6'3" TO 8'0"	8
8'3" TO 10'0"	10
10'3" TO 12'0"	12
12'3" TO 14'0"	14
14'3" TO 16'0"	16
16'3" TO 18'0"	18

MAX. SECTION HEIGHT: 24"



SECTION 1 - 1

BOTTOM SECTION REINFORCED WITH TEMPERED ALUMINUM EXTRUSION WITH INTEGRAL RETAINER FOR FLEXIBLE VINYL ASTRAGAL

CLOPAY CORP. ALL RIGHTS RESERVED.

Third Angle Projection

Unless Stated Otherwise TOLERANCES are  
 .0 = ±.03125  
 .0000 = ±.015  
 .0000 = ±.005  
 .0000 = ±.001  
 Degrees = ± 1/2"

Unless Stated Otherwise DIMENSIONS ARE IN INCHES.



8585 Duke Boulevard  
Mason, OH 45040 USA  
Tel. No. 513-770-4800  
Fax No. 513-770-4853

MARK WESTERFIELD, P.E.  
FLORIDA P.E. #48495, NC P.E. #23832.  
TEXAS P.E. #91513

MANUFACTURING PRODUCT CODE: MPC: C-PAN-1E448

WINDLOAD RATING  
W6

DESCRIPTION: COMMERCIAL RIBBED DOOR			
DRAWN BY: RJK	DATE: 10/15/01	SCALE: NOTED	DWG. B
CHECKED BY: MWW	DATE: 10/01	SHEET 1 OF 1	SIZE B
DWG. NO.: 102446			