

MODELS AVAILABLE (CLOPAY/ HOLMES/ IDEAL)  
 MODELS 524, 520/ 224/ C4ST, C0ST  
 INSULATED MODELS 524S, 520S, 524V/ 224S/ C4SS, C0SS, C4SV

SHEET:  
 1 OF 4

REVISIONS					
REV. NO.	ZONE	DATE	ECN NO.	APPVD:	DESCRIPTION
09	-	08/2016	-	SH	REMOVED WIND SPEED TABLE.

DOOR WIDTH	NUMBER OF CENTER STILES
UP TO 9'-2"	1
9'-3" THRU 12'-2"	2

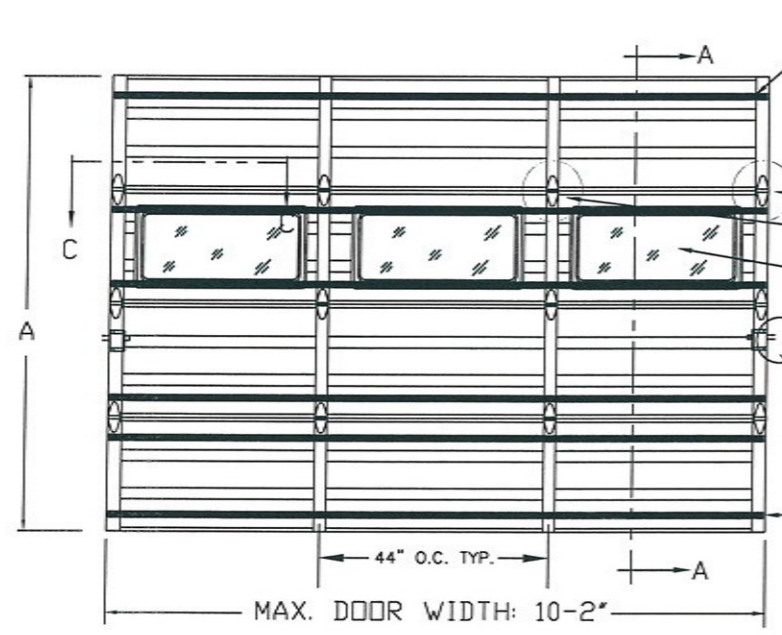

OPTIONAL GLAZING MUST BE DSB OR BETTER AND IS NOT IMPACT-RESISTANT. ONLY SOLID DOORS ARE IMPACT RESISTANT. MAXIMUM GLAZING SIZE (DLO) IS 21-5/8"x9-5/8". SEE SECTION B-B ON SHEET 2 FOR DETAILS. GLAZING MAY BE INSTALLED IN TOP SECTION (NOT SHOWN) OR INTERMEDIATE SECTION (SHOWN).

MIN. TWO POINT LOCKING REQ'D.  
 U-BAR. SEE SECTION A-A FOR MOUNTING DETAILS AND SPECIFICATIONS.

DOOR HEIGHT 'A'	NUMBER OF SECTIONS
UP TO 8'-0"	4
8'-3" THRU 10'-0"	5
10'-3" THRU 12'-0"	6
12'-3" THRU 14'-0"	7
14'-3" THRU 16'-0"	8
16'-3" THRU 18'-0"	9

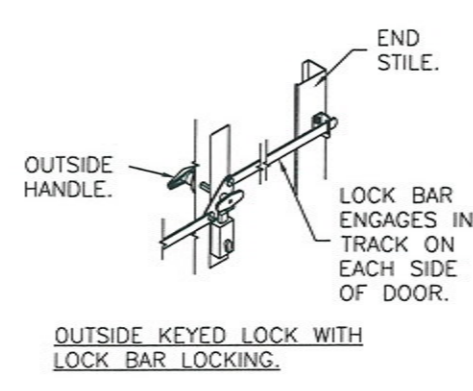
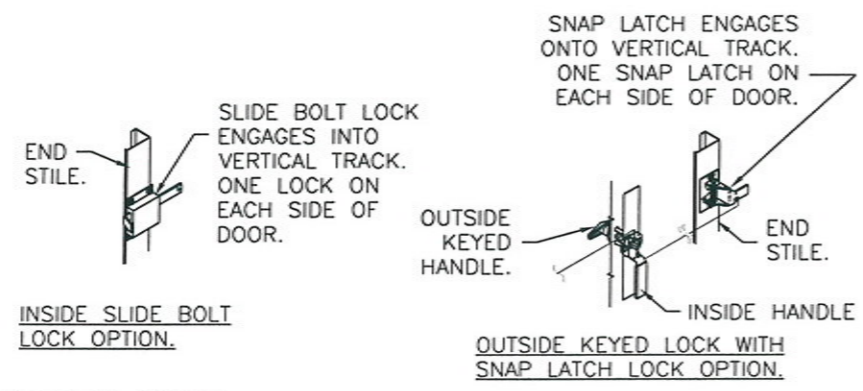
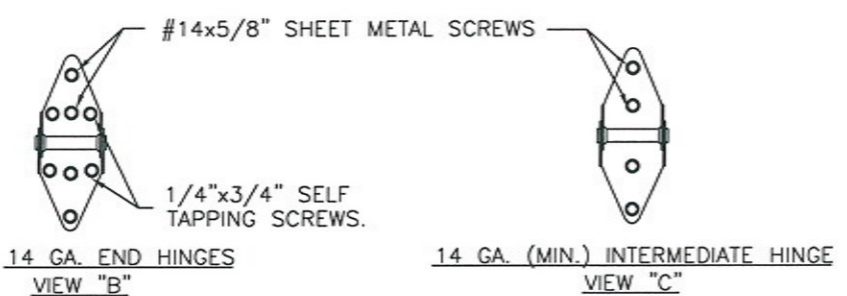

DESIGN LOADS: +37.0 P.S.F. & -44.0 P.S.F.  
 TEST LOADS: +55.5 P.S.F. & -66.0 P.S.F.  
 Unless Stated Otherwise  
 TOLERANCES are  
 .0 = ±.031  
 .00 = ±.015  
 .000 = ±.005  
 .0000 = ±.001  
 Degrees = ±1/2'  
 Unless Stated Otherwise  
 DIMENSIONS ARE IN INCHES.

**Clopay**  
 Building Products Company  
 8585 Duke Boulevard  
 Mason, OH 45040 USA  
 Tel. No. 513-770-4800  
 Fax No. 513-770-4853

MANUFACTURING PRODUCT CODE C-PAN-1E448
PART NO.: N/A
WINDLOAD RATING W6 DP37

DESCRIPTION: COMMERCIAL RIBBED DOORS UP TO 10'2"W (SEE TABLE)			
DRAWN BY: SH	DATE: 1/10/14	SCALE: NTS	DWG. SIZE B
CHECKED BY: SH	DATE: 1/10/14	SHEET 1 OF 4	
DWG. NO.: 102445 - A/B	VER: TDI		

STATE OF TEXAS  
 MARK W. WESTERFIELD  
 8/12/16  
 DESIGN ENGINEER  
 FLORIDA P.E. #48495, NC P.E. #23832, TEXAS P.E. #91513

MODELS AVAILABLE (CLOPAY/ HOLMES/ IDEAL)  
 MODELS 524, 520/ 224/ C4ST, COST  
 INSULATED MODELS 524S, 520S, 524V/ 224S/ C4SS, COSS, C4SV

SHEET:  
 2 OF 4

REVISIONS					DESCRIPTION
REV. NO.	ZONE:	DATE:	ECN NO.	APPVD:	
09	-	-	-	-	SEE REVISION HISTORY ON SHEET ONE.

**STANDARD ASSEMBLY CONSTRUCTION:**  
 OPTIONAL LITES WITH DSB OR TEMPERED INSULATED GLAZING AVAILABLE.  
 THE ENTIRE DOOR ASSEMBLY INSTALLED IN COMPLIANCE WITH THIS SECTION MEETS THE WIND LOAD REQUIREMENTS OF THE FLORIDA BUILDING CODE OR INTERNATIONAL BUILDING CODE BUT DOES NOT MEET THE IMPACT RESISTANT REQUIREMENT FOR WINDBORNE DEBRIS REGIONS (REF. CHAPTER 16 FBC/IBC).

**SECTION B-B  
 (NON-IMPACT-RESISTANT  
 GLAZING OPTION)**

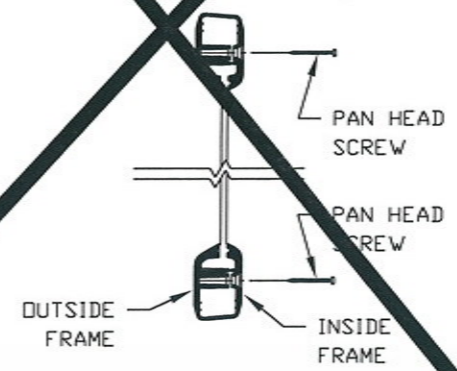

**IMPACT-RESISTANT CONSTRUCTION:**  
 SOLID DOORS (NO GLAZING) ARE IMPACT-RESISTANT.  
 THE ENTIRE DOOR ASSEMBLY INSTALLED IN COMPLIANCE WITH THIS SECTION MEETS THE WIND LOAD REQUIREMENTS OF THE FLORIDA BUILDING CODE AND INTERNATIONAL BUILDING CODE AND IS LARGE- AND SMALL-MISSILE IMPACT RESISTANT.

**IMPACT-RESISTANT ASSEMBLY DETAILS  
 DRAWING 102445-A**

**STANDARD ASSEMBLY DETAILS  
 DRAWING 102445-B**

DESIGN ENGINEER:  
 MARK WESTERFIELD, P.E.  
 FLORIDA P.E. #48495; NC P.E. #23832, TEXAS P.E. #91513  
 8/12/16

DESIGN LOADS: +37.0 P.S.F. & -44.0 P.S.F.  
 TEST LOADS: +55.5 P.S.F. & -66.0 P.S.F.

Unless Stated Otherwise  
**TOLERANCES are**  
 .0 = ±.031  
 .00 = ±.015  
 .000 = ±.005  
 .0000 = ±.001  
 Degrees = ± 1/2'



8585 Duke Boulevard  
 Mason, OH 45040 USA  
 Tel. No. 513-770-4800  
 Fax No. 513-770-4853

MANUFACTURING PRODUCT CODE  
 C-PAN-1E448  
 PART NO.: N/A

WINDLOAD RATING  
 W6 DP37

DESCRIPTION: COMMERCIAL RIBBED DOORS UP TO 10'2"W (SEE TABLE)

DRAWN BY: SH DATE: 1/10/14 SCALE: NTS DWG. SIZE: B  
 CHECKED BY: SH DATE: 1/10/14 SHEET 2 OF 4

DWG. NO.: 102445 - A/B VER: TDI



MODELS AVAILABLE (CLOPAY/ HOLMES/ IDEAL)  
 MODELS 524, 520/ 224/ C4ST, COST  
 INSULATED MODELS 524S, 520S, 524V/ 224S/ C4SS, COSS, C4SV

SHEET:  
 3 OF 4

REVISIONS					DESCRIPTION
REV. NO.	ZONE:	DATE:	ECN NO.	APPVD:	
09	-	-	-	-	SEE REVISION HISTORY ON SHEET ONE.

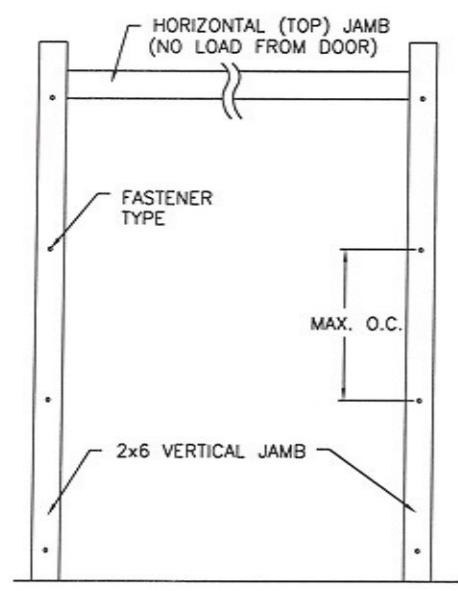

**JAMB TO SUPPORTING STRUCTURE ATTACHMENT**

- NOTES:**
1. ALL THE LOAD FROM THE DOOR IS TRANSFERRED TO THE TRACK AND THEN FROM THE TRACK TO THE 2x6 VERTICAL SYP (GRADE #2 OR BETTER) JAMBS. NO LOAD FROM THE DOOR IS TRANSFERRED TO THE HORIZONTAL (TOP) JAMB.
  2. EACH VERTICAL JAMB SEES A MAXIMUM DESIGN LOAD OF +185 LB & -220 LB. PER LINEAR FOOT OF JAMB.
  3. ALL JAMB FASTENERS MAY BE (BUT ARE NOT REQUIRED TO BE) COUNTERSUNK TO PROVIDE A FLUSH MOUNTING SURFACE.
  4. A 1/3 STRESS INCREASE FOR WIND LOAD WAS NOT USED IN THE CALCULATION OF ALLOWABLE LOADS FOR ANCHORS AND FASTENERS FOR STEEL, CONCRETE AND MASONRY.

**NOTE:** 2x6 WOOD JAMBS ARE NOT REQUIRED WITH CONTINUOUS ANGLE MOUNT TRACK. HOWEVER, IF DESIRED ON STEEL JAMBS OR CONCRETE OR BLOCK WALLS, APPROVED FASTENERS AS DETAILED BELOW SHOULD BE INCREASED IN LENGTH BY 1-1/2" AND INSTALLED DIRECTLY THROUGH THE ANGLE AND 2x6 WOOD JAMBS INTO THE STEEL JAMBS OR CONCRETE OR BLOCK WALLS. ANCHORS CAN BE (BUT ARE NOT REQUIRED TO BE) COUNTERSUNK TO PROVIDE A FLUSH MOUNTING SURFACE. CONTINUOUS ANGLE TRACK CAN BE ANCHORED DIRECTLY TO GROUT REINFORCED BLOCK WALL OR 3,000 PSI MIN. CONCRETE COLUMN OR STEEL JAMBS.

SECTIONS ARE 1-7/8" THICK PANELS ROLL FORMED OF .022" MIN. HOT DIPPED G-40 GALVANIZING, ROLL FORMED STEEL.

ADJUSTABLE TOP ROLLER BRACKET OF 12 GA. GALV. STEEL, INSTALLED ON DOOR WITH (4) #14 X 5/8" LG SHEET METAL SCREWS

TONGUE & GROOVE JOINT.

END HINGE. SEE DETAILS AT VIEW "B" ON SHEET 1.

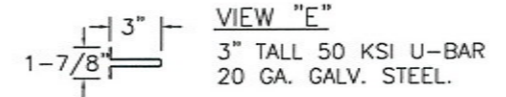

3" x 20GA. STEEL U-BARS IN A 2-1-2-1 PATTERN, STARTING WITH THE BOTTOM SECTION. ATTACHED WITH (2) 1/4"x3/4" SELF-TAPPING SCREWS PER HINGE LOCATION. (SEE VIEW "E")

(2) STACKED LHR BRACKETS USED AS INNER BOTTOM BRACKET (NOT SHOWN).

BOTTOM SECTION REINFORCED WITH TEMPERED ALUMINUM EXTRUSION WITH INTEGRAL RETAINER FOR FLEXIBLE VINYL ASTRAGAL

BOTTOM ROLLER BRACKET OF 12 GA. MIN. GALV. STEEL, FASTENED WITH (4) #14 X 5/8" LG SHT. MTL. SCREWS

SECTION A-A (SIDE VIEW)

**FASTENER ATTACHMENT TO SUPPORTING STRUCTURE SCHEDULES**

BUILDING TYPE	FASTENER TYPE	MAXIMUM ON-CENTER DISTANCE BETWEEN FASTENERS	STEEL WASHERS REQUIRED?
HOLLOW BLOCK WALL	1/4" x 1-1/4" MIN. EMBED ULTRACON CONCRETE ANCHOR	9"	1" O.D.
GROUT FILLED BLOCK WALL	1/4" x 1-3/4" MIN. EMBED ULTRACON CONCRETE ANCHOR	14-3/4"	1" O.D.
2000 PSI MIN. CONCRETE	1/4" x 1" MIN. EMBED ULTRACON CONCRETE ANCHOR	12-3/4"	1" O.D.
2000 PSI MIN. CONCRETE	1/4" x 1" MIN. EMBED TAPCON CONCRETE ANCHOR	11"	1" O.D.
2000 PSI MIN. CONCRETE	3/8" x 1-3/4" MIN. EMBED WEJ-IT ANKR TITE SLEEVE ANCHOR	24"	INCLUDED
4000 PSI MIN. CONCRETE	3/8" x 1-3/4" MIN. EMBED WEJ-IT ANKR TITE SLEEVE ANCHOR	24"	INCLUDED
WOOD FRAME (SYP 0.55 SG)	1/2" x 3" LAG SCREW (ASTM A307, GRADE A) 1-5/8" EMBED INTO STRUCTURE	24"	1" O.D.
14GA STEEL (0.060" MIN.)	1/4"-14 x 1" ITW BUILDEX TEKS SELF-DRILLING FASTENER	12-1/4"	1" O.D.
12GA STEEL (0.105" MIN.)	1/4"-14 x 1" ITW BUILDEX TEKS SELF-DRILLING FASTENER	21-1/2"	1" O.D.
1/8" STEEL	1/4"-14 x 1" ITW BUILDEX TEKS SELF-DRILLING FASTENER	24"	1" O.D.

\* FIRST (BOTTOM) ANCHOR STARTING AT NO MORE THAN HALF OF THE MAXIMUM ON-CENTER DISTANCE. HIGHEST ANCHOR INSTALLED AT LEAST AS HIGH AS THE DOOR OPENING.  
 CLOPAY DOES NOT SUPPLY JAMB ATTACHMENT FASTENERS.  
 MINIMUM DISTANCE BETWEEN CENTER OF ANCHOR AND EDGE OF CONCRETE BLOCK: 2-1/2", EXCLUDING STUCCO THICKNESS.

DESIGN LOADS: +37.0 P.S.F. & -44.0 P.S.F.  
 TEST LOADS: +55.5 P.S.F. & -66.0 P.S.F.

Unless Stated Otherwise TOLERANCES are  
 .0 = ±.031  
 .00 = ±.015  
 .000 = ±.005  
 .0000 = ±.001  
 Degrees = ±1/2'



8585 Duke Boulevard  
 Mason, OH 45040 USA  
 Tel. No. 513-770-4800  
 Fax No. 513-770-4853

MANUFACTURING PRODUCT CODE  
**C-PAN-1E448**

PART NO.: N/A  
 WINDLOAD RATING  
**W6 DP37**

DESCRIPTION: COMMERCIAL RIBBED DOORS UP TO 10'2"W (SEE TABLE)

DRAWN BY: SH DATE: 1/10/14 SCALE: NTS DWG. SIZE B  
 CHECKED BY: SH DATE: 1/10/14 SHEET 3 OF 4

DWG. NO.: 102445 - A/B VER: TDI

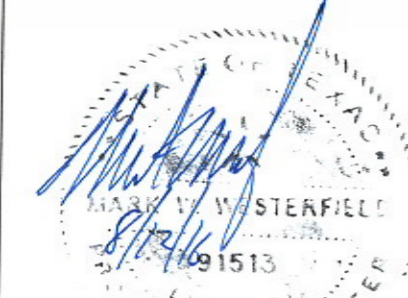

DESIGN ENGINEER:  
 MARK WESTERFIELD, P.E.  
 FLORIDA P.E. #48495, NC P.E. #23832, TEXAS P.E. #91513



MODELS AVAILABLE (CLOPAY/ HOLMES/ IDEAL)  
 MODELS 524, 520/ 224/ C4ST, COST  
 INSULATED MODELS 524S, 520S, 524V/ 224S/ C4SS, COSS, C4SV

SHEET:  
4 OF 4

REVISIONS					DESCRIPTION
REV. NO.	ZONE:	DATE:	ECN NO.	APPVD:	
09	-	-	-	-	SEE REVISION HISTORY ON SHEET ONE.

**2" TRACK CONFIGURATION**  
DOORS UP TO 800 LBS.

NOTE DOUBLE TRACK HEADROOM, HI-LIFT TRACK, FOLLOW-THE-ROOF TRACK, AND VERTICAL LIFT TRACK ARE AVAILABLE OPTIONS. TRACK CONFIGURATION ABOVE THE DOOR OPENING DOES NOT AFFECT THE WIND LOAD RATING.

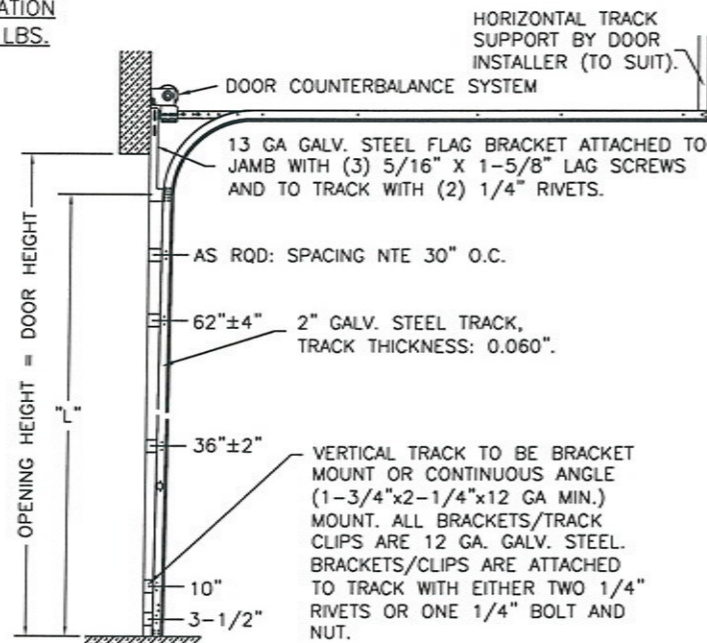

DOOR HEIGHT	"L"
6'-6"	70"
7'-0"	76"
7'-6"	82"
8'-0"	88"
8'-6"	94"
9'-0"	100"
9'-6"	106"
10'-0"	112"
10'-6"	118"
11'-0"	124"
11'-6"	130"
12'-0"	136"
12'-6"	142"
13'-0"	148"
13'-6"	154"
14'-0"	160"
14'-6"	166"
15'-0"	172"
15'-6"	178"
16'-0"	184"
16'-6"	190"
17'-0"	196"
17'-6"	202"
18'-0"	208"

**JAMB CONFIGURATION**  
DOORS UP TO 800 LBS.

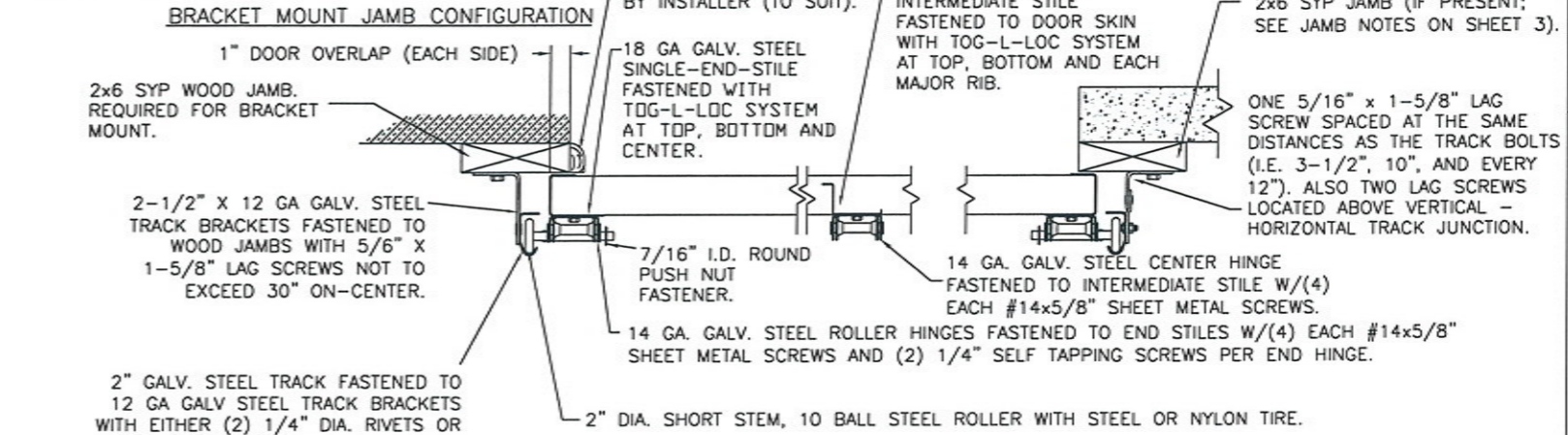

SECTION C-C  
PREPARATION OF JAMBS BY OTHERS.

LHR BRACKET (2-1/2" x 5-3/4" x 12GA) ATTACHED WITH (2) 1/4" x 3/4" SELF TAPPING SCREWS. NOTE THAT LHR BRACKETS ARE ALSO USED WITH "DOUBLE END STILE" AS SHOWN IN ZONE B-3 SHEET 1.

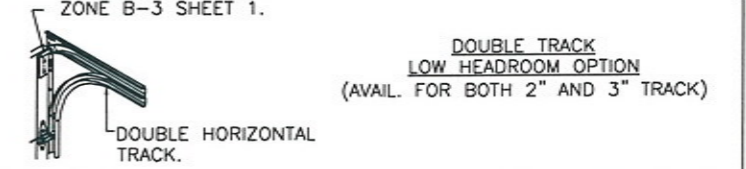

**3" TRACK CONFIGURATION**  
DOORS 800 LBS AND OVER.

NOTE DOUBLE TRACK HEADROOM, HI-LIFT TRACK, FOLLOW-THE-ROOF TRACK, AND VERTICAL LIFT TRACK ARE AVAILABLE OPTIONS. TRACK CONFIGURATION ABOVE THE DOOR OPENING DOES NOT AFFECT THE WIND LOAD RATING.

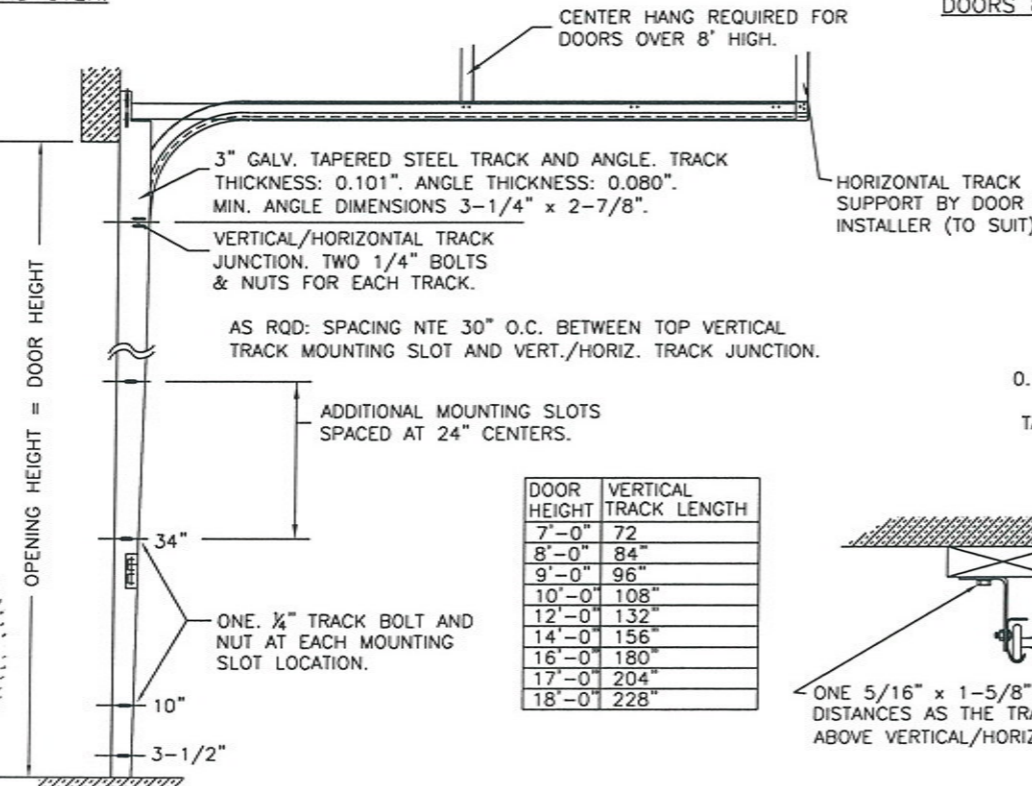

DOOR HEIGHT	VERTICAL TRACK LENGTH
7'-0"	72"
8'-0"	84"
9'-0"	96"
10'-0"	108"
12'-0"	132"
14'-0"	156"
16'-0"	180"
17'-0"	204"
18'-0"	228"

**JAMB CONFIGURATION**  
DOORS 800 LBS AND OVER.

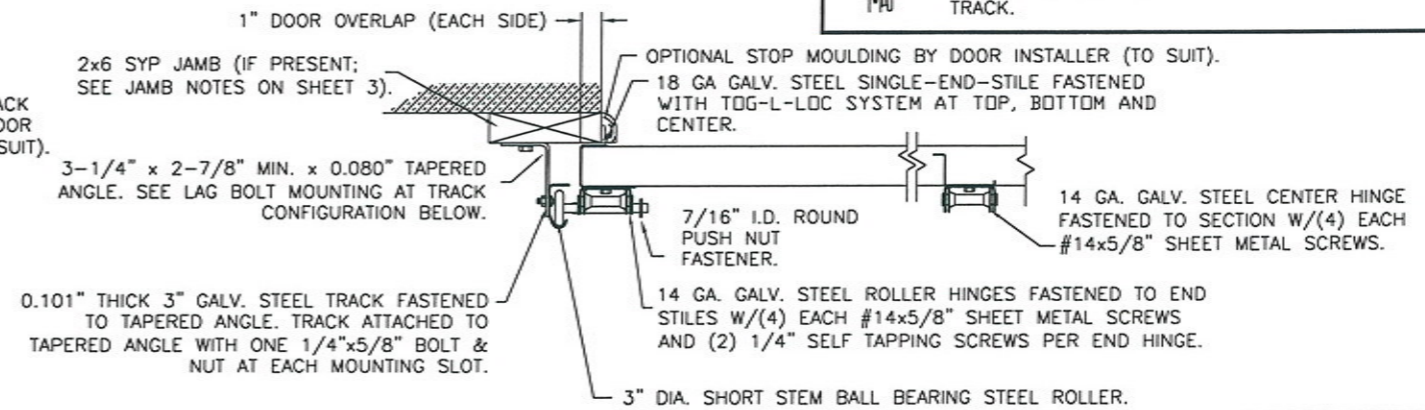

SECTION C-C  
PREPARATION OF JAMBS BY OTHERS.

DESIGN LOADS: +37.0 P.S.F. & -44.0 P.S.F.  
 TEST LOADS: +55.5 P.S.F. & -66.0 P.S.F.

Unless Stated Otherwise  
**TOLERANCES are**  
 .0 = ±.031  
 .00 = ±.015  
 .000 = ±.005  
 .0000 = ±.001  
 Degrees = ±1/2'

Unless Stated Otherwise  
 DIMENSIONS ARE IN INCHES.

**Glopay**  
 Building Products Company  
 8585 Duke Boulevard  
 Mason, OH 45040 USA  
 Tel. No. 513-770-4800  
 Fax No. 513-770-4853

MANUFACTURING PRODUCT CODE  
C-PAN-1E448

PART NO.: N/A

WINDLOAD RATING  
W6 DP37

DESCRIPTION: COMMERCIAL RIBBED DOORS UP TO 10'2"W (SEE TABLE)

DRAWN BY: SH DATE: 1/10/14 SCALE: NTS DWG. SIZE B  
 CHECKED BY: SH DATE: 1/10/14 SHEET 4 OF 4

DWG. NO.: 102445 - A/B VER: TDI

DESIGN ENGINEER:  
 MARK WESTERFIELD, P.E.  
 FLORIDA P.E. #48495, NC P.E. #23832, TEXAS P.E. #91513

