

MODELS AVAILABLE (CLOPAY/ HOLMES/ IDEAL)
 MODELS 524, 520/ 224/ C4ST, C0ST
 INSULATED MODELS 524S, 520S, 524V/ 224S/ C4SS, C0SS, C4SV

SHEET:
 1 OF 4

REVISIONS					DESCRIPTION
REV. NO.	ZONE:	DATE:	ECN NO.	APPVD:	
09	-	08/2016	-	SH	REMOVED WIND SPEED TABLE.

DOOR WIDTH	NUMBER OF CENTER STILES
UP TO 9'-2"	1
9'-3" THRU 12'-2"	2

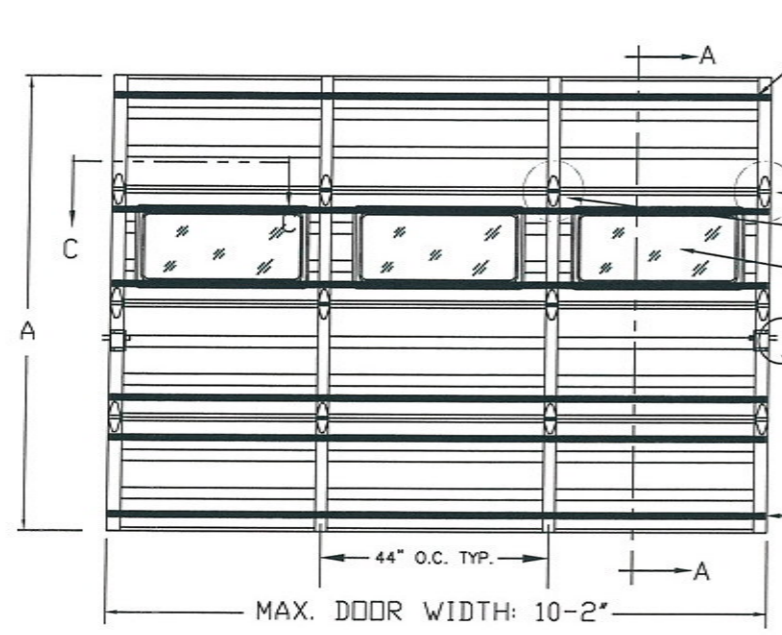

END STILE

VIEW "B"

VIEW "C"

OPTIONAL GLAZING MUST BE DSB OR BETTER AND IS NOT IMPACT-RESISTANT. ONLY SOLID DOORS ARE IMPACT RESISTANT. MAXIMUM GLAZING SIZE (DLO) IS 21-5/8"x9-5/8". SEE SECTION B-B ON SHEET 2 FOR DETAILS. GLAZING MAY BE INSTALLED IN TOP SECTION (NOT SHOWN) OR INTERMEDIATE SECTION (SHOWN).

MIN. TWO POINT LOCKING REQ'D.

U-BAR. SEE SECTION A-A FOR MOUNTING DETAILS AND SPECIFICATIONS.

44" O.C. TYP.

MAX. DOOR WIDTH: 10'-2"

DOOR HEIGHT 'A'	NUMBER OF SECTIONS
UP TO 8'-0"	4
8'-3" THRU 10'-0"	5
10'-3" THRU 12'-0"	6
12'-3" THRU 14'-0"	7
14'-3" THRU 16'-0"	8
16'-3" THRU 18'-0"	9

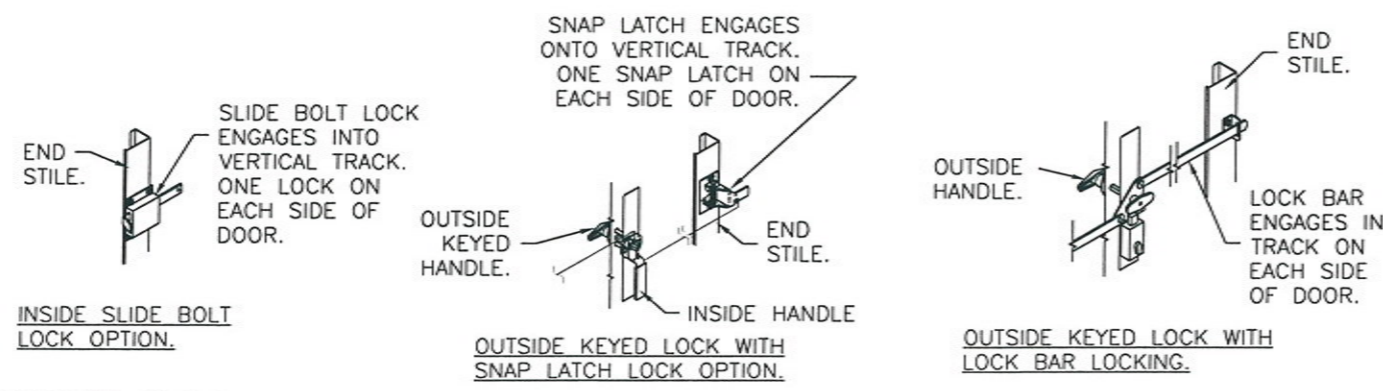
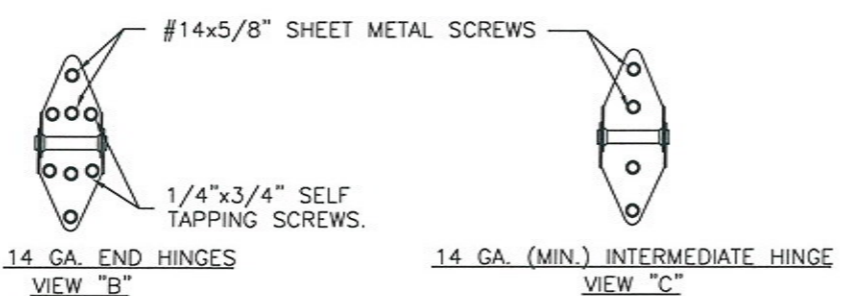

DESIGN LOADS: +37.0 P.S.F. & -44.0 P.S.F.
 TEST LOADS: +55.5 P.S.F. & -66.0 P.S.F.

Unless Stated Otherwise TOLERANCES are

.0 = ±.031
 .00 = ±.015
 .000 = ±.005
 .0000 = ±.001
 Degrees = ± 1/2'

Unless Stated Otherwise DIMENSIONS ARE IN INCHES.

Clopay Building Products Company
 8585 Duke Boulevard
 Mason, OH 45040 USA
 Tel. No. 513-770-4800
 Fax No. 513-770-4853

MANUFACTURING PRODUCT CODE C-PAN-1E448	
PART NO.: N/A	
WINDLOAD RATING W6 DP37	
DESCRIPTION: COMMERCIAL RIBBED DOORS UP TO 10'2"W (SEE TABLE)	
DRAWN BY: SH	DATE: 1/10/14
CHECKED BY: SH	DATE: 1/10/14
DWG. NO.: 102445 - A/B	VER: TDI

DESIGN ENGINEER:
 MARK WESTERFIELD, P.E.
 FLORIDA P.E. #48495, NC P.E. #23832, TEXAS P.E. #91513

MODELS AVAILABLE (CLOPAY/ HOLMES/ IDEAL)
 MODELS 524, 520/ 224/ C4ST, C0ST
 INSULATED MODELS 524S, 520S, 524V/ 224S/ C4SS, C0SS, C4SV

SHEET:
 2 OF 4

REVISIONS					
REV. NO.	ZONE	DATE	ECN NO.	APPVD:	DESCRIPTION
09	-	-	-	-	SEE REVISION HISTORY ON SHEET ONE.

STANDARD ASSEMBLY CONSTRUCTION:
 OPTIONAL LITES WITH DSB OR TEMPERED INSULATED GLAZING AVAILABLE.
 THE ENTIRE DOOR ASSEMBLY INSTALLED IN COMPLIANCE WITH THIS SECTION MEETS THE WIND LOAD REQUIREMENTS OF THE FLORIDA BUILDING CODE OR INTERNATIONAL BUILDING CODE BUT DOES NOT MEET THE IMPACT RESISTANT REQUIREMENT FOR WINDBORNE DEBRIS REGIONS (REF. CHAPTER 16 FBC/IBC).

**SECTION B-B
 (NON-IMPACT-RESISTANT
 GLAZING OPTION)**

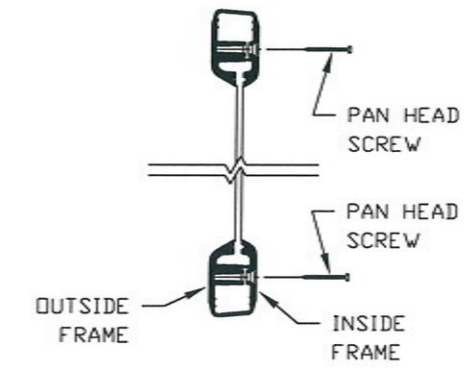

**STANDARD ASSEMBLY DETAILS
 DRAWING 102445-B**

IMPACT-RESISTANT CONSTRUCTION:
 SOLID DOORS (NO GLAZING) ARE IMPACT RESISTANT.
 THE ENTIRE DOOR ASSEMBLY INSTALLED IN COMPLIANCE WITH THIS SECTION MEETS THE WIND LOAD REQUIREMENTS OF THE FLORIDA BUILDING CODE AND INTERNATIONAL BUILDING CODE AND IS LARGE- AND SMALL-MISSILE IMPACT RESISTANT.

**IMPACT-RESISTANT ASSEMBLY DETAILS
 DRAWING 102445-A**



DESIGN LOADS: +37.0 P.S.F. & -44.0 P.S.F.
 TEST LOADS: +55.5 P.S.F. & -66.0 P.S.F.

Unless Stated Otherwise
TOLERANCES are
 .0 = ±.031
 .00 = ±.015
 .000 = ±.005
 .0000 = ±.001
 Degrees = ±1/2°

Clopay
 Building Products Company
 8585 Duke Boulevard
 Mason, OH 45040 USA
 Tel. No. 513-770-4800
 Fax No. 513-770-4853

MANUFACTURING PRODUCT CODE
 C-PAN-1E448
 PART NO.: N/A

WINDLOAD RATING
 W6 DP37

DESCRIPTION: COMMERCIAL RIBBED DOORS UP TO 10'2"W (SEE TABLE)

DRAWN BY: SH	DATE: 1/10/14	SCALE: NTS	DWG. SIZE B
CHECKED BY: SH	DATE: 1/10/14	SHEET 2 OF 4	

DWG. NO.: 102445 - A/B VER: TDI

DESIGN ENGINEER:
 MARK WESTERFIELD, P.E.
 FLORIDA P.E. #48495, NC P.E. #23832, TEXAS P.E. #91513

MODELS AVAILABLE (CLOPAY/ HOLMES/ IDEAL)
 MODELS 524, 520/ 224/ C4ST, COST
 INSULATED MODELS 524S, 520S, 524V/ 224S/ C4SS, COSS, C4SV

SHEET:
 3 OF 4

REVISIONS					
REV. NO.	ZONE:	DATE:	ECN NO.	APPVD:	DESCRIPTION
09	-	-	-	-	SEE REVISION HISTORY ON SHEET ONE.

JAMB TO SUPPORTING STRUCTURE ATTACHMENT

NOTES:

1. ALL THE LOAD FROM THE DOOR IS TRANSFERRED TO THE TRACK AND THEN FROM THE TRACK TO THE 2x6 VERTICAL JAMB (GRADE #2 OR BETTER) JAMBS. NO LOAD FROM THE DOOR IS TRANSFERRED TO THE HORIZONTAL (TOP) JAMB.
2. EACH VERTICAL JAMB SEES A MAXIMUM DESIGN LOAD OF +185 LB & -220 LB. PER LINEAR FOOT OF JAMB.
3. ALL JAMB FASTENERS MAY BE (BUT ARE NOT REQUIRED TO BE) COUNTERSUNK TO PROVIDE A FLUSH MOUNTING SURFACE.
4. A 1/3 STRESS INCREASE FOR WIND LOAD WAS NOT USED IN THE CALCULATION OF ALLOWABLE LOADS FOR ANCHORS AND FASTENERS FOR STEEL, CONCRETE AND MASONRY.

NOTE: 2x6 WOOD JAMBS ARE NOT REQUIRED WITH CONTINUOUS ANGLE MOUNT TRACK. HOWEVER, IF DESIRED ON STEEL JAMBS OR CONCRETE OR BLOCK WALLS, APPROVED FASTENERS AS DETAILED BELOW SHOULD BE INCREASED IN LENGTH BY 1-1/2" AND INSTALLED DIRECTLY THROUGH THE ANGLE AND 2x6 WOOD JAMBS INTO THE STEEL JAMBS OR CONCRETE OR BLOCK WALLS. ANCHORS CAN BE (BUT ARE NOT REQUIRED TO BE) COUNTERSUNK TO PROVIDE A FLUSH MOUNTING SURFACE. CONTINUOUS ANGLE TRACK CAN BE ANCHORED DIRECTLY TO GROUT REINFORCED BLOCK WALL OR 3,000 PSI MIN. CONCRETE COLUMN OR STEEL JAMBS.

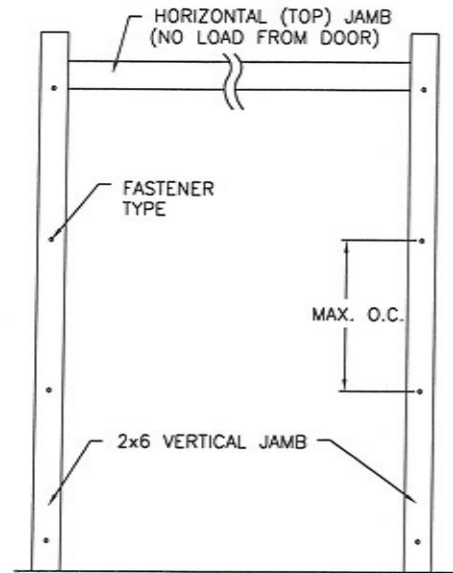

SECTIONS ARE 1-7/8" THICK PANELS ROLL FORMED OF .022" MIN. HOT DIPPED G-40 GALVANIZING, ROLL FORMED STEEL.

ADJUSTABLE TOP ROLLER BRACKET OF 12 GA. GALV. STEEL, INSTALLED ON DOOR WITH (4) #14 X 5/8" LG SHEET METAL SCREWS

TONGUE & GROOVE JOINT.

END HINGE. SEE DETAILS AT VIEW "B" ON SHEET 1.

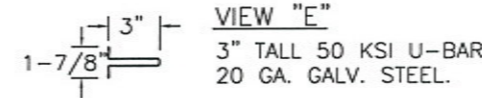

3" x 20GA. STEEL U-BARS IN A 2-1-2-1 PATTERN, STARTING WITH THE BOTTOM SECTION. ATTACHED WITH (2) 1/4"x3/4" SELF-TAPPING SCREWS PER HINGE LOCATION. (SEE VIEW "E")

(2) STACKED LHR BRACKETS USED AS INNER BOTTOM BRACKET (NOT SHOWN).

BOTTOM SECTION REINFORCED WITH TEMPERED ALUMINUM EXTRUSION WITH INTEGRAL RETAINER FOR FLEXIBLE VINYL ASTRAGAL

BOTTOM ROLLER BRACKET OF 12 GA. MIN. GALV. STEEL, FASTENED WITH (4) #14 X 5/8" LG SHT. MTL. SCREWS

SECTION A-A (SIDE VIEW)

FASTENER ATTACHMENT TO SUPPORTING STRUCTURE SCHEDULES

BUILDING TYPE	FASTENER TYPE	MAXIMUM ON-CENTER DISTANCE BETWEEN FASTENERS*	STEEL WASHERS REQUIRED?
HOLLOW BLOCK WALL	1/4" x 1-1/4" MIN. EMBED ULTRACON CONCRETE ANCHOR	9"	1" O.D.
GROUT FILLED BLOCK WALL	1/4" x 1-3/4" MIN. EMBED ULTRACON CONCRETE ANCHOR	14-3/4"	1" O.D.
2000 PSI MIN. CONCRETE	1/4" x 1" MIN. EMBED ULTRACON CONCRETE ANCHOR	12-3/4"	1" O.D.
2000 PSI MIN. CONCRETE	1/4" x 1" MIN. EMBED TAPCON CONCRETE ANCHOR	11"	1" O.D.
2000 PSI MIN. CONCRETE	3/8" x 1-3/4" MIN. EMBED WEJ-IT ANKR TITE SLEEVE ANCHOR	24"	INCLUDED
4000 PSI MIN. CONCRETE	3/8" x 1-3/4" MIN. EMBED WEJ-IT ANKR TITE SLEEVE ANCHOR	24"	INCLUDED
WOOD FRAME (SYP 0.55 SG)	1/2" x 3" LAG SCREW (ASTM A307, GRADE A) 1-5/8" EMBED INTO STRUCTURE	24"	1" O.D.
14GA STEEL (0.060" MIN.)	1/4"-14 x 1" ITW BUILDEX TEKS SELF-DRILLING FASTENER	12-1/4"	1" O.D.
12GA STEEL (0.105" MIN.)	1/4"-14 x 1" ITW BUILDEX TEKS SELF-DRILLING FASTENER	21-1/2"	1" O.D.
1/8" STEEL	1/4"-14 x 1" ITW BUILDEX TEKS SELF-DRILLING FASTENER	24"	1" O.D.

* FIRST (BOTTOM) ANCHOR STARTING AT NO MORE THAN HALF OF THE MAXIMUM ON-CENTER DISTANCE. HIGHEST ANCHOR INSTALLED AT LEAST AS HIGH AS THE DOOR OPENING.
 CLOPAY DOES NOT SUPPLY JAMB ATTACHMENT FASTENERS.
 MINIMUM DISTANCE BETWEEN CENTER OF ANCHOR AND EDGE OF CONCRETE BLOCK: 2-1/2", EXCLUDING STUCCO THICKNESS.

DESIGN LOADS: +37.0 P.S.F. & -44.0 P.S.F.
 TEST LOADS: +55.5 P.S.F. & -66.0 P.S.F.

Unless Stated Otherwise
TOLERANCES are
 .0 = ±.031
 .00 = ±.015
 .000 = ±.005
 .0000 = ±.001
 Degrees = ±1/2"

Unless Stated Otherwise
 DIMENSIONS ARE IN INCHES.



8585 Duke Boulevard
 Mason, OH 45040 USA
 Tel. No. 513-770-4800
 Fax No. 513-770-4853

MANUFACTURING PRODUCT CODE
 C-PAN-1E448

PART NO.: N/A

WINDLOAD RATING
 W6 DP37

DESCRIPTION: COMMERCIAL RIBBED DOORS UP TO 10'2"W (SEE TABLE)

DRAWN BY: SH DATE: 1/10/14 SCALE: NTS DWG. SIZE B
 CHECKED BY: SH DATE: 1/10/14 SHEET 3 OF 4

DWG. NO.: 102445 - A/B VER: TDI

DESIGN ENGINEER:
 MARK WESTERFIELD, P.E.
 FLORIDA P.E. #48495, NC P.E. #23832, TEXAS P.E. #91513

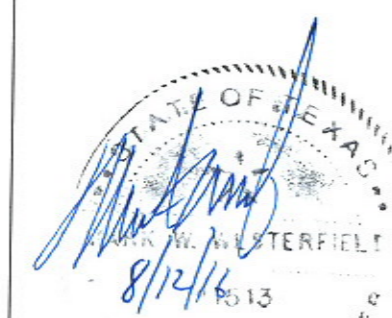

MODELS AVAILABLE (CLOPAY/ HOLMES/ IDEAL)
 MODELS 524, 520/ 224/ C4ST, COST
 INSULATED MODELS 524S, 520S, 524V/ 224S/ C4SS, COSS, C4SV

SHEET: 4 OF 4	REVISIONS					
	REV. NO.	ZONE:	DATE:	ECN NO.	APPVD:	DESCRIPTION
	09	-	-	-	-	SEE REVISION HISTORY ON SHEET ONE.

2" TRACK CONFIGURATION
DOORS UP TO 800 LBS.

NOTE DOUBLE TRACK HEADROOM, HI-LIFT TRACK, FOLLOW-THE-ROOF TRACK, AND VERTICAL LIFT TRACK ARE AVAILABLE OPTIONS. TRACK CONFIGURATION ABOVE THE DOOR OPENING DOES NOT AFFECT THE WIND LOAD RATING.

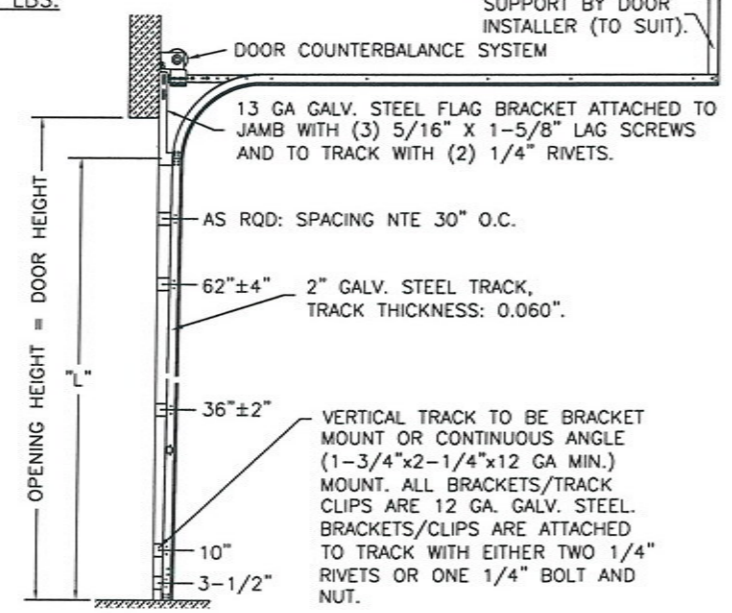

DOOR HEIGHT "L"	"L"
6'-6"	70"
7'-0"	76"
7'-6"	82"
8'-0"	88"
8'-6"	94"
9'-0"	100"
9'-6"	106"
10'-0"	112"
10'-6"	118"
11'-0"	124"
11'-6"	130"
12'-0"	136"
12'-6"	142"
13'-0"	148"
13'-6"	154"
14'-0"	160"
14'-6"	166"
15'-0"	172"
15'-6"	178"
16'-0"	184"
16'-6"	190"
17'-0"	196"
17'-6"	202"
18'-0"	208"

JAMB CONFIGURATION
DOORS UP TO 800 LBS.

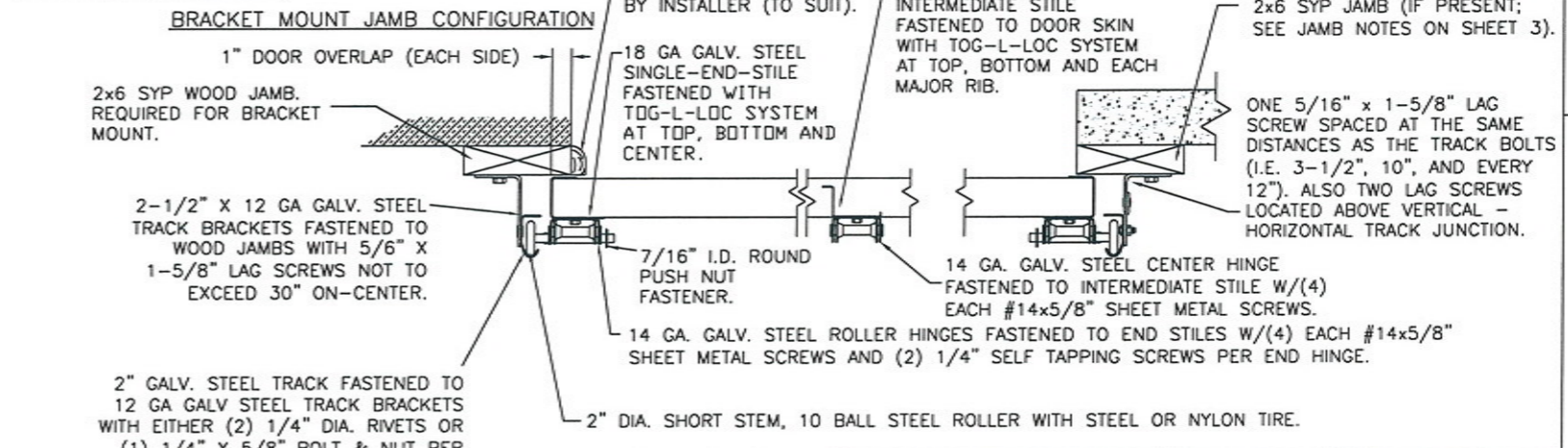

3" TRACK CONFIGURATION
DOORS 800 LBS AND OVER.

NOTE DOUBLE TRACK HEADROOM, HI-LIFT TRACK, FOLLOW-THE-ROOF TRACK, AND VERTICAL LIFT TRACK ARE AVAILABLE OPTIONS. TRACK CONFIGURATION ABOVE THE DOOR OPENING DOES NOT AFFECT THE WIND LOAD RATING.

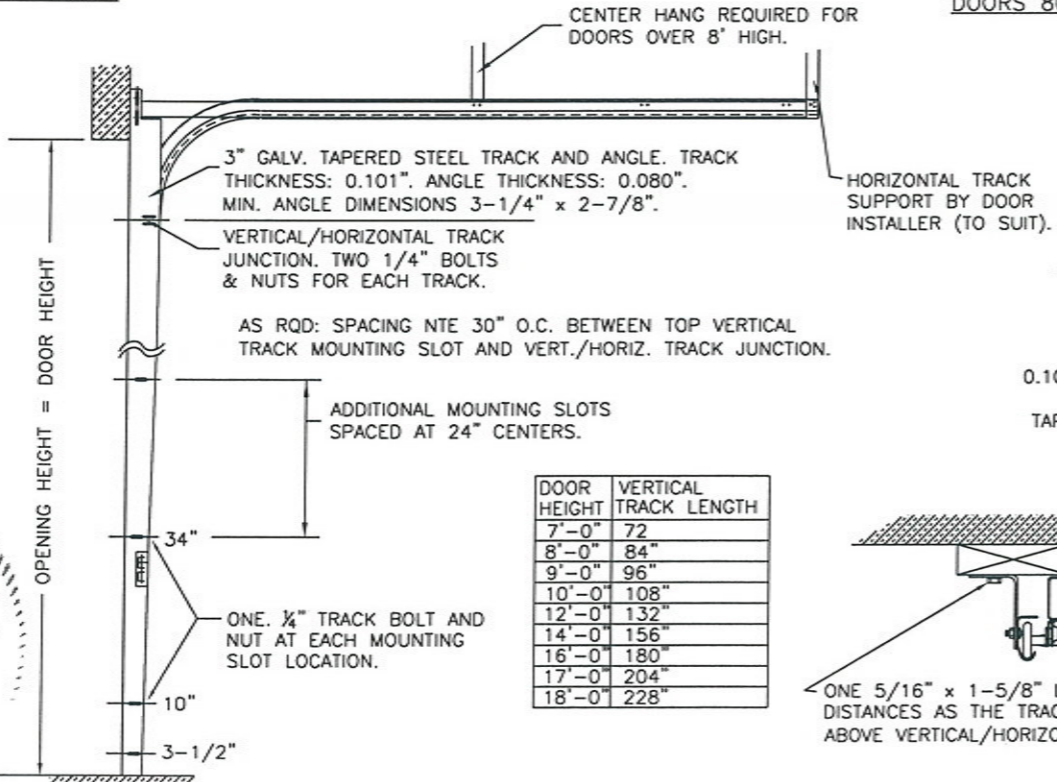

DOOR HEIGHT	VERTICAL TRACK LENGTH
7'-0"	72"
8'-0"	84"
9'-0"	96"
10'-0"	108"
12'-0"	132"
14'-0"	156"
16'-0"	180"
17'-0"	204"
18'-0"	228"

JAMB CONFIGURATION
DOORS 800 LBS AND OVER.

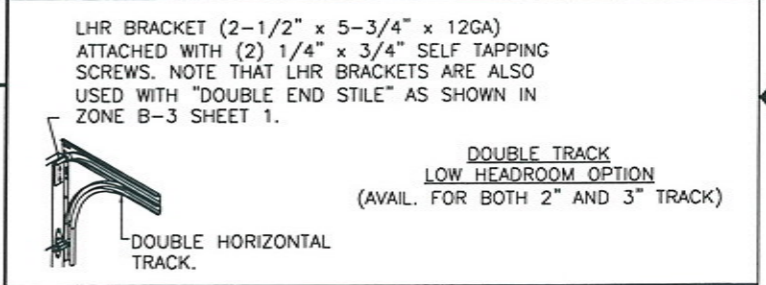
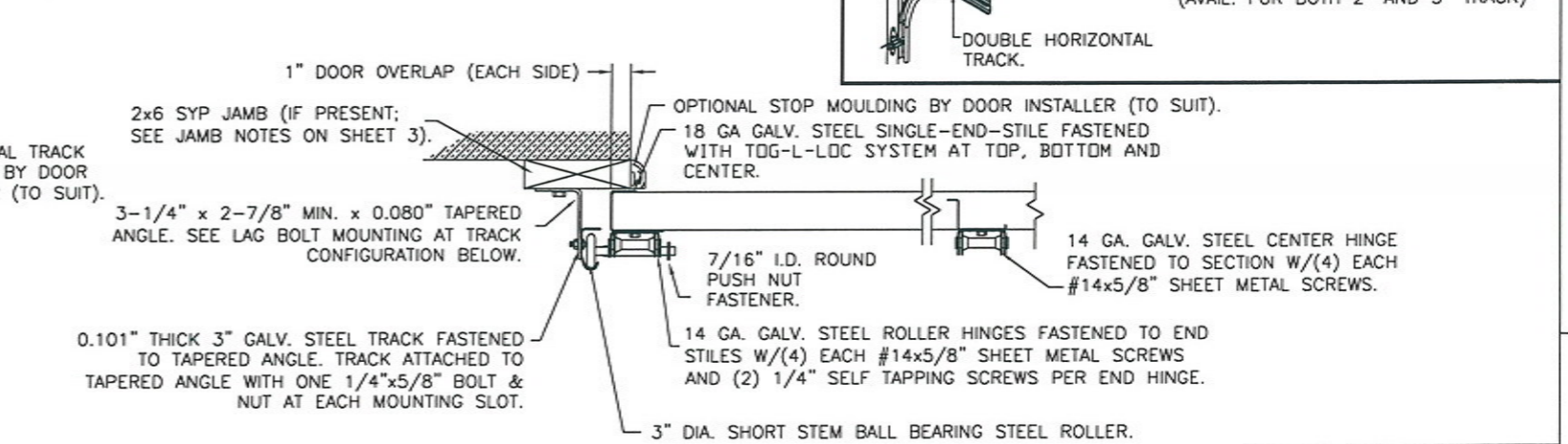

DESIGN ENGINEER:
 MARK WESTERFIELD, P.E.
 FLORIDA P.E. #48495, NC P.E. #23832, TEXAS P.E. #91513

SECTION C-C
PREPARATION OF JAMBS BY OTHERS.

DESIGN LOADS: +37.0 P.S.F. & -44.0 P.S.F.
 TEST LOADS: +55.5 P.S.F. & -66.0 P.S.F.

Unless Stated Otherwise TOLERANCES are

.0	= ±.031
.00	= ±.015
.000	= ±.005
.0000	= ±.001
Degrees	= ±1/2'

Unless Stated Otherwise DIMENSIONS ARE IN INCHES.

Clopay
 Building Products Company
 8585 Duke Boulevard
 Mason, OH 45040 USA
 Tel. No. 513-770-4800
 Fax No. 513-770-4853

MANUFACTURING PRODUCT CODE
 C-PAN-1E448

PART NO.: N/A
 WINDLOAD RATING
 W6 DP37

DESCRIPTION: COMMERCIAL RIBBED DOORS UP TO 10'2"W (SEE TABLE)	SCALE: NTS	DWG. SIZE: B
DRAWN BY: SH	DATE: 1/10/14	SHEET 4 OF 4
CHECKED BY: SH	DATE: 1/10/14	VER: TDI
DWG. NO.: 102445 - A/B		