

CLOPAY MODEL 3200 (24 GA MIN EXT SKIN)  
 CLOPAY MODEL 3220 (20 GA MIN EXT SKIN)  
 HOLMES MODEL 240/240G (24 GA MIN EXT SKIN)

REV	DATE	DESCRIPTION
9	08/2012	REVISED FOR TDI
10	06/2013	REMOVE GLAZING OPTION
11	08/2016	REMOVE WIND SPEED TABLE.

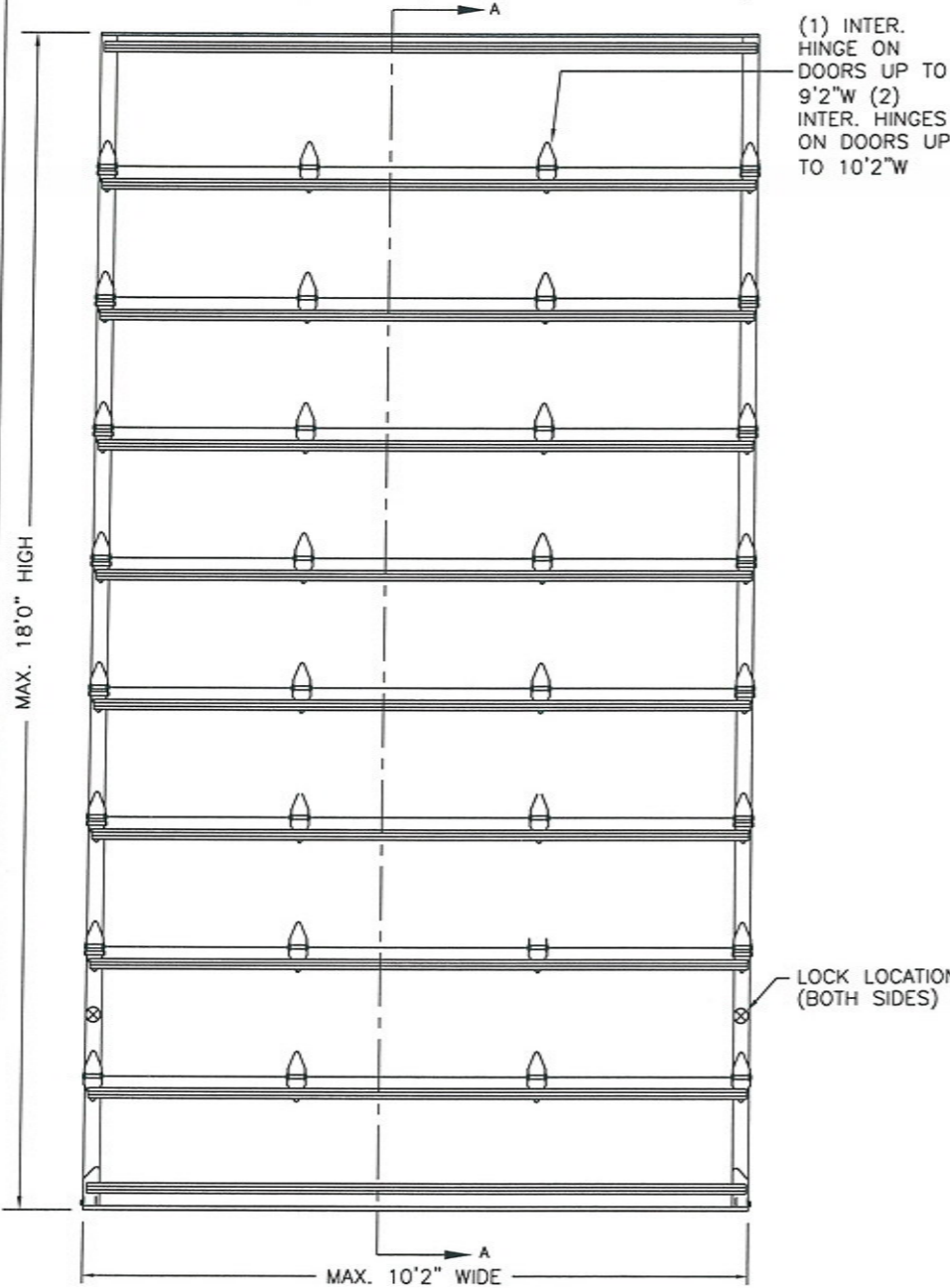

(1) INTER. HINGE ON DOORS UP TO 9'2"W (2) INTER. HINGES ON DOORS UP TO 10'2"W

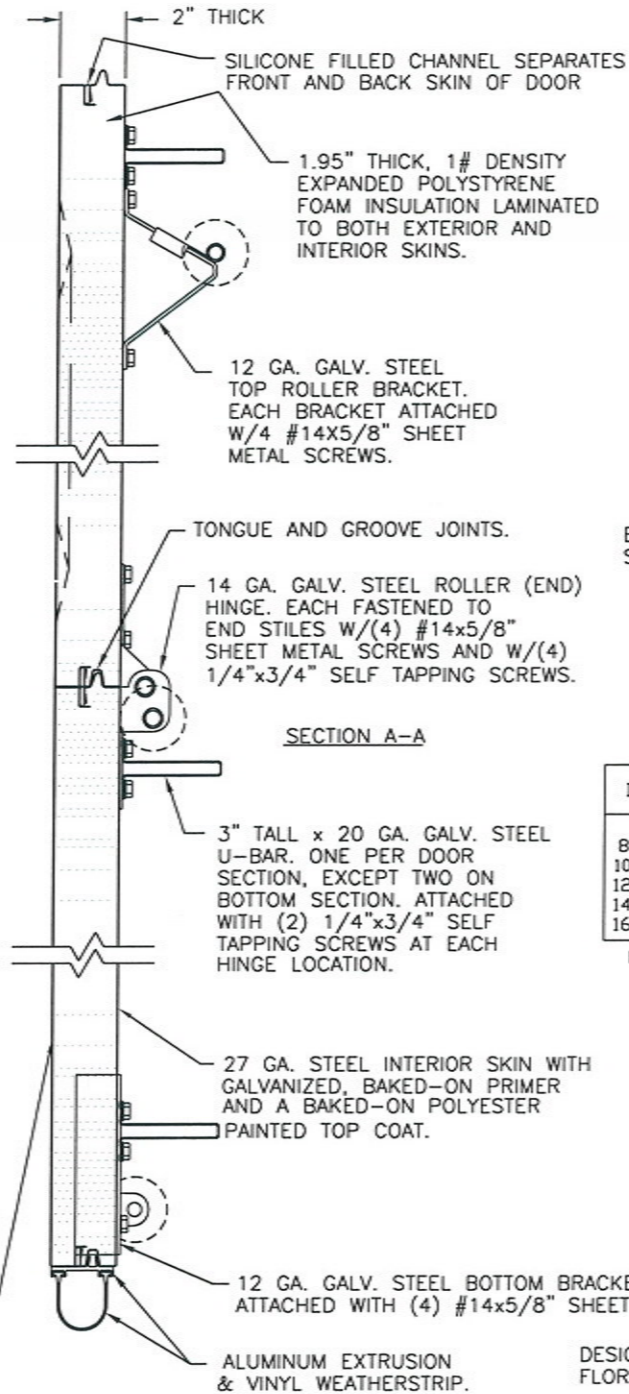

SECTION A-A

DOOR HEIGHT 'A'	NUMBER OF SECTIONS
UP TO 8'-0"	4
8'-3" THRU 10'-0"	5
10'-3" THRU 12'-0"	6
12'-3" THRU 14'-0"	7
14'-3" THRU 16'-0"	8
16'-3" THRU 18'-0"	9

MAX. SECTION HEIGHT: 24"

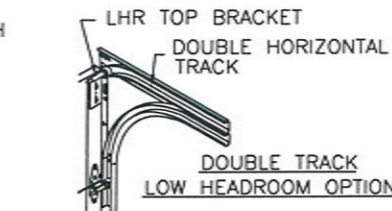

DESIGN ENGINEER: MARK WESTERFIELD, P.E.  
 FLORIDA P.E. #48495, NC P.E. #23832, TEXAS P.E. #91513  
 DESIGN LOADS: +37.0 PSF & -40.0 PSF  
 TEST LOADS: +55.5 PSF & -60.0 PSF

THE OPTIONAL GLAZING SHOWN ON THIS DRAWING MEETS THE WIND LOAD REQUIREMENTS OF THE FLORIDA BUILDING CODE OR INTERNATIONAL BUILDING CODE BUT DOES NOT MEET THE IMPACT RESISTANT REQUIREMENT FOR WINDBORNE DEBRIS REGIONS (REF. CHAPTER 16 FBC/IBC)

THE SUPPORTING STRUCTURAL ELEMENTS ARE TO BE DESIGNED BY THE BUILDING ARCHITECT OR ENGINEER OF RECORD FOR THE LOADS SHOWN ON THIS DRAWING.

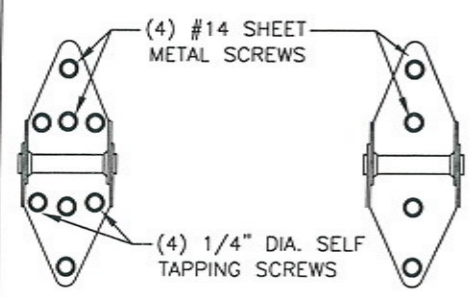
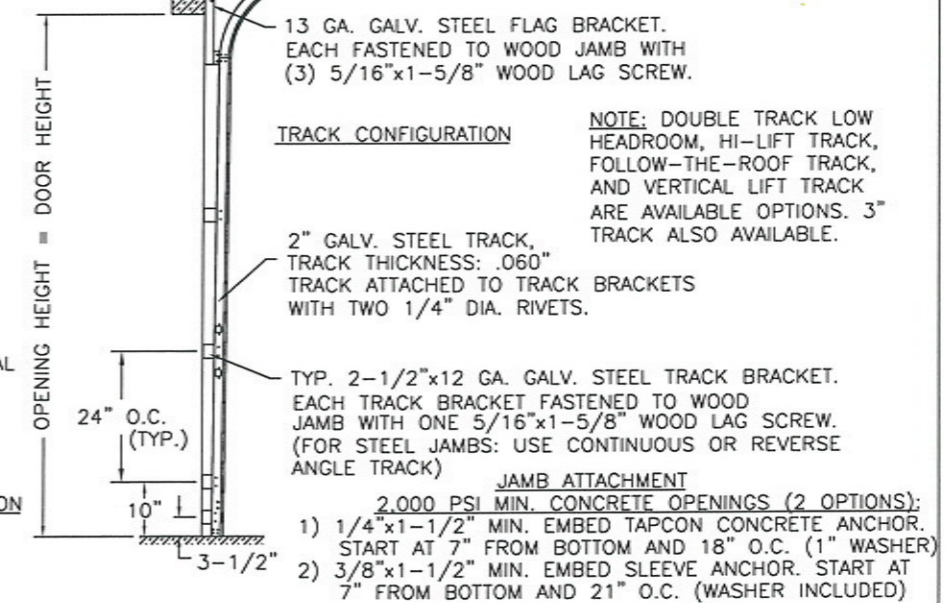
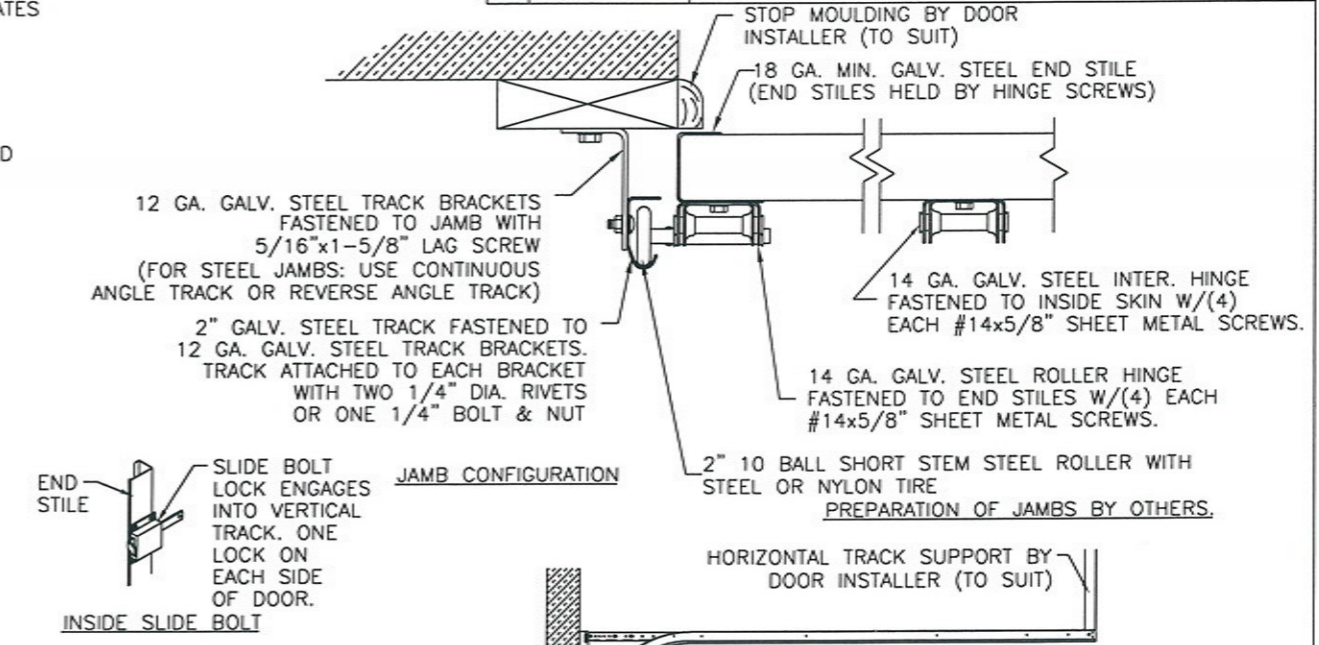

14 GA. END HINGE 14 GA. INTERMEDIATE HINGE



CLOPAY BUILDING PRODUCTS COMPANY  
 8585 DUKE BLVD.  
 MASON, OH 45040  
 (513) 770 - 4800  
 Clipay Corporation All Rights Reserved.

MANUFACTURING PRODUCT CODE: MPC: C-DSIE-1F448	WINDLOAD RATING W6	MAX DOOR SIZE: 10'2"W x 18'0"H
DATE: 4/18/96	DESCRIPTION: COMM 2" EPS: +37/-40 PSF DESIGN	DRAWING NUMBER: B 101617
DRAWN BY: MWW		
CHECKED BY:		