

BRAND	MODERN STEEL		COMMERCIAL DOORS	
	FLUSH	GROOVED	FLUSH	GROOVED
CLOPAY	9208, HDPC2	9209, HDPCR2	3728	3729
HOLMES	7208	7209	--	C7R20

SEE SHEET 5 FOR "CANYON RIDGE MODERN SERIES" MODELS.

SHEET:
1 OF 5

REVISIONS					DESCRIPTION
REV. NO.	ZONE	DATE	ECN NO.	APPVD:	
01	-	10/19/16	-	SH	REVISED MPC.
02	-	06/25/20	-	SH	ADDED CRM MODELS, REVISED FOR TDI.
03	-	01/19/21	-	SH	NOTED CODE COMPLIANCE
04	-	09/14/21	-	JDW	REVISED FOR TDI.

MIXED GLAZING SHOWN.

(1) 20 GA. BACKER EXTERNAL PLATE AT EACH INTERMEDIATE HINGE LOCATION, ATTACHED WITH DOUBLE SIDED ACRYLIC ADHESIVE TO BACK OF DOOR.

OPTIONAL IMPACT RESISTANT GLAZING. MAXIMUM GLAZING SIZE (DLO) IS 39-1/4"x13-1/4". GLAZING MAY BE SHORT-PANEL OR LONG-PANEL. SEE SECTION B-B ON SHEET 2 FOR DETAILS. GLAZING MAY BE INSTALLED IN ANY LOCATION IN ANY OR ALL SECTIONS.

DOOR HEIGHT	# OF SECTIONS	# OF U-BARS
UP TO 6'0"	3	5
6'3" TO 8'0"	4	6
8'3" TO 10'0"	5	8
10'3" TO 12'0"	6	9
12'3" TO 14'0"	7	11
14'3" TO 16'0"	8	12
16'3" TO 18'0"	9	14
18'3" TO 20'0"	10	15

MAX SECTION HEIGHT: 24"

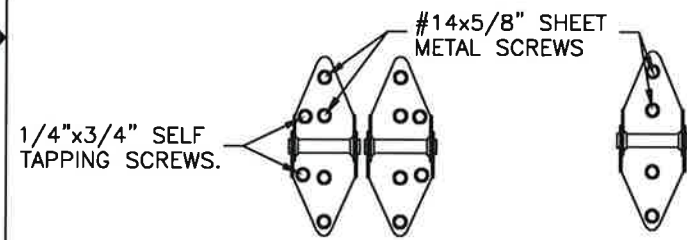
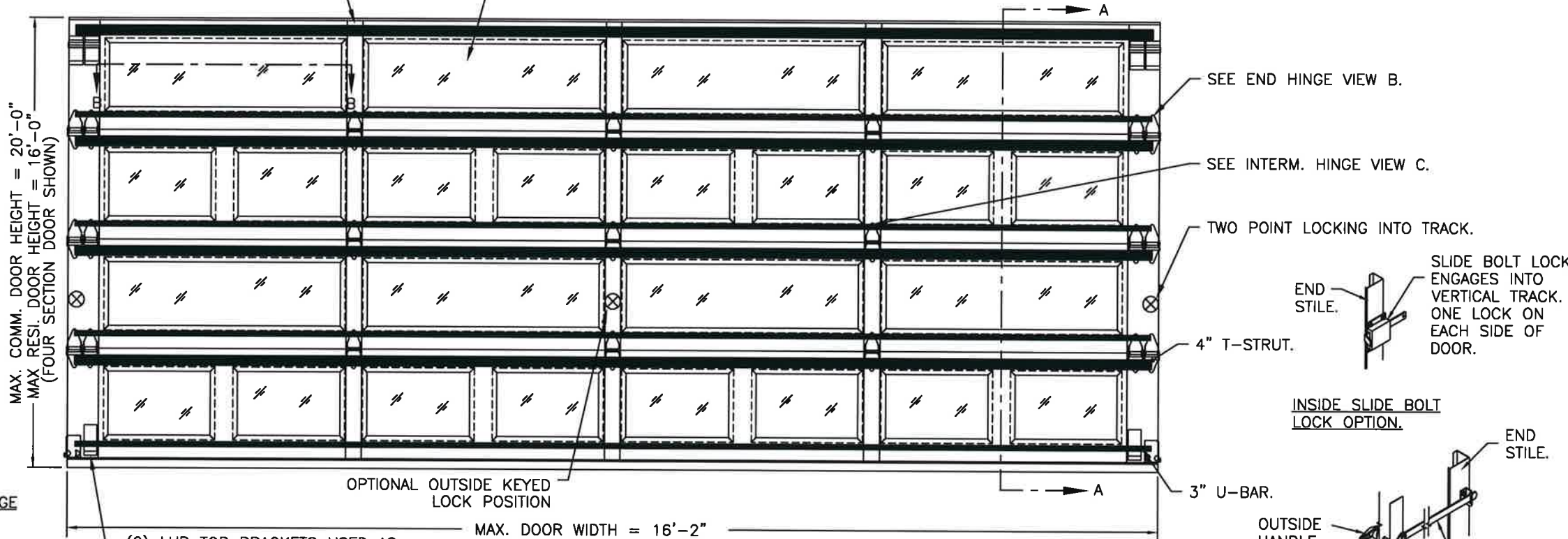

14 GA. END HINGES VIEW "B" 14 GA. INTERMEDIATE HINGE VIEW "C"

(2) LHR TOP BRACKETS USED AS INNER BOTTOM BRACKET.
(1) 3-IN ROLLER CARRIER (P/N 0120394) USED WITH 3" TRACK.

MAX. DOOR WIDTH = 16'-2"
MAX. OPENING WIDTH = 16'-0".
SEE JAMB NOTES ON SHEET 4.

REPRESENTATIVE GLAZING PATTERNS.

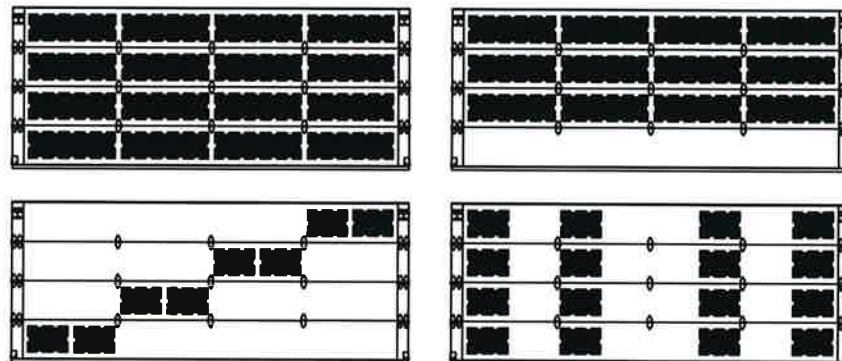

GLAZING MAY BE IN ANY LOCATION IN ANY OR ALL SECTIONS. THESE PATTERNS ARE REPRESENTATIVE OF THE APPROVED CONFIGURATIONS. NOT ALL CONFIGURATIONS ARE AVAILABLE AS STANDARD PRODUCT. CONSULT FACTORY FOR DETAILS.

SNAP LATCH ENGAGES ONTO VERTICAL TRACK. ONE SNAP LATCH ON EACH SIDE OF DOOR.

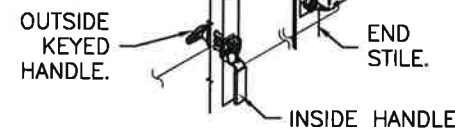

OUTSIDE KEYED LOCK WITH SNAP LATCH LOCK OPTION.

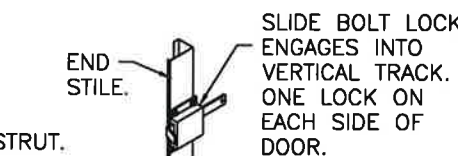

INSIDE SLIDE BOLT LOCK OPTION.

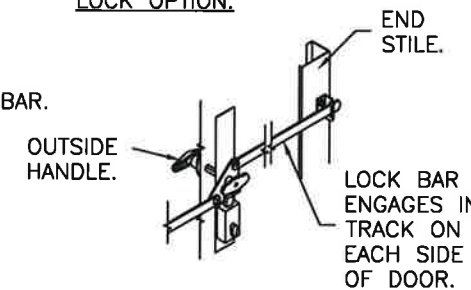

OUTSIDE KEYED LOCK WITH LOCK BAR LOCKING.

THIS PRODUCT COMPLIES WITH THE 2018 IBC/IRC.

DESIGN LOADS: +46.0 P.S.F. & -52.0 P.S.F.
TEST LOADS: +69.0 P.S.F. & -78.0 P.S.F.

Unless Stated Otherwise
TOLERANCES are
.0 = ±.031
.00 = ±.015
.000 = ±.005
.0000 = ±.001
Degrees = ±1/2'

Unless Stated Otherwise
DIMENSIONS ARE IN INCHES.

Clopay CORPORATION
8585 Duke Boulevard
Mason, OH 45040 USA
Tel. No. 513-770-4800
Fax No. 513-770-4853

DESCRIPTION: MODERN STEEL 2" INTELICORE +46/-52 PSF TO 16' W

DRAWN BY: SH DATE: 12/2015 SCALE: NTS DWG. B
CHECKED BY: -- DATE: -- SHEET 1 OF 5 SIZE

DWG. NO.: 105002 VER: TDI

MANUFACTURING PRODUCT CODE
DSIUA-1F477

PART NO.: N/A

WINDLOAD RATING
W8 DP46T



DESIGN ENGINEER:
MARK WESTERFIELD, P.E.
FLORIDA P.E. #48493, NC P.E. #23832, TEXAS P.E. #91513

BRAND	MODERN STEEL		COMMERCIAL DOORS	
	FLUSH	GROOVED	FLUSH	GROOVED
CLOPAY	9208, HDPC2	9209, HDPCR2	3728	3729
HOLMES	7208	7209	--	C7R20

SEE SHEET 5 FOR "CANYON RIDGE MODERN SERIES" MODELS.

SHEET:
2 OF 5

REVISIONS					
REV. NO.	ZONE:	DATE:	ECN NO.	APPVD:	DESCRIPTION
04	-	-	-	-	SEE REVISION HISTORY ON SHEET ONE.

IMPACT-RESISTANT CONSTRUCTION:
 SOLID DOORS (NO GLAZING) OR DOORS WITH OPTIONAL IMPACT-RESISTANT GLAZING ARE IMPACT-RESISTANT. OPTIONAL IMPACT RESISTANT ASSEMBLY CONSISTS OF ALUMINUM FRONT FRAME AND SABIC IP LEXAN 9034 (VERSIONS ALSO APPROVED: MR10, 9030, 9031B, 90316, 90317, 90311, 90314, 90355) OR BAYER MAKROLON GP (VERSIONS ALSO APPROVED: SL, AR, 15), APPROVED CC1 PLASTICS IN ACCORDANCE WITH IBC/FBC 2606 AND AN APPROVED C1 PLASTIC IN ACCORDANCE WITH FBC 2612. THE ENTIRE DOOR ASSEMBLY INSTALLED IN COMPLIANCE WITH THIS SECTION MEETS THE WIND LOAD REQUIREMENTS OF THE FLORIDA BUILDING CODE AND INTERNATIONAL BUILDING CODE AND IS LARGE- AND SMALL-MISSILE IMPACT RESISTANT.

SECTION B-B (IMPACT-RESISTANT GLAZING OPTION)

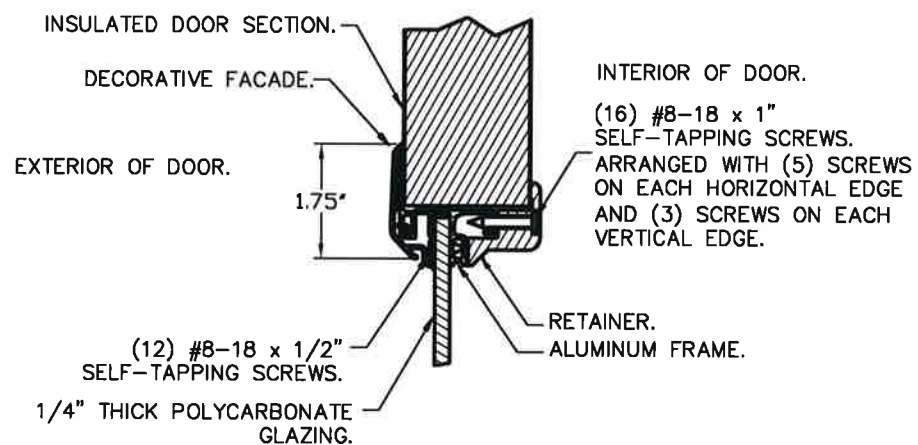

D
C
B
A

D
C
B
A

DESIGN ENGINEER:
 MARK WESTERFIELD, P.E.
 FLORIDA P.E. #48495, NC P.E. #23832, TEXAS P.E. #91513

DESIGN LOADS: +46.0 P.S.F. & -52.0 P.S.F.
 TEST LOADS: +69.0 P.S.F. & -78.0 P.S.F.

Unless Stated Otherwise
 TOLERANCES are
 .0 = ±.031
 .00 = ±.015
 .000 = ±.005
 .0000 = ±.001
 Degrees = ±1/2'
 Unless Stated Otherwise
 DIMENSIONS ARE IN INCHES.

8585 Duke Boulevard
 Mason, OH 45040 USA
 Tel. No. 513-770-4800
 Fax No. 513-770-4853

MANUFACTURING PRODUCT CODE
 DSIUA-1F477

PART NO.: N/A

WINDLOAD RATING
 W8 DP46T

DESCRIPTION: MODERN STEEL 2" INTELICORE +46/-52 PSF TO 16' W

DRAWN BY: SH	DATE: 12/2015	SCALE: NTS	DWG. B
CHECKED BY: --	DATE: --	SHEET 2 OF 5	SIZE B
DWG. NO.: 105002		VER: TDI	

BRAND	MODERN STEEL		COMMERCIAL DOORS	
	FLUSH	GROOVED	FLUSH	GROOVED
CLOPAY	9208, HDPC2	9209, HDPCR2	3728	3729
HOLMES	7208	7209	--	C7R20

SEE SHEET 5 FOR "CANYON RIDGE MODERN SERIES" MODELS.

SHEET 3 OF 5

REVISIONS					DESCRIPTION
REV. NO.	ZONE	DATE	ECN NO.	APPVD:	
04	-	-	-	-	SEE REVISION HISTORY ON SHEET ONE.

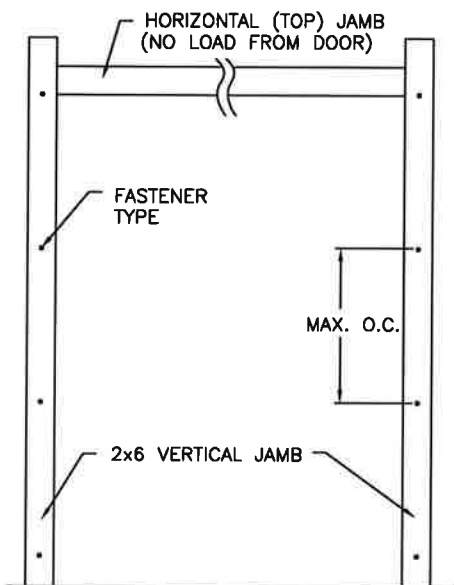

JAMB TO SUPPORTING STRUCTURE ATTACHMENT

- NOTES:**
1. ALL THE LOAD FROM THE DOOR IS TRANSFERRED TO THE TRACK AND THEN FROM THE TRACK TO THE 2x6 VERTICAL SYP (GRADE #2 OR BETTER) JAMBS. NO LOAD FROM THE DOOR IS TRANSFERRED TO THE HORIZONTAL (TOP) JAMB.
 2. EACH VERTICAL JAMB SEES A MAXIMUM DESIGN LOAD OF +368 LB & -416 LB. PER LINEAR FOOT OF JAMB.
 3. ALL JAMB FASTENERS MAY BE (BUT ARE NOT REQUIRED TO BE) COUNTERSUNK TO PROVIDE A FLUSH MOUNTING SURFACE.
 4. A 1/3 STRESS INCREASE FOR WIND LOAD WAS NOT USED IN THE CALCULATION OF ALLOWABLE LOADS FOR ANCHORS AND FASTENERS FOR STEEL, CONCRETE AND MASONRY.

NOTE: 2x6 WOOD JAMBS ARE NOT REQUIRED WITH CONTINUOUS ANGLE MOUNT TRACK. HOWEVER, IF DESIRED ON STEEL JAMBS OR CONCRETE OR BLOCK WALLS, APPROVED FASTENERS AS DETAILED BELOW SHOULD BE INCREASED IN LENGTH BY 1-1/2" AND INSTALLED DIRECTLY THROUGH THE ANGLE AND 2x6 WOOD JAMBS INTO THE STEEL JAMBS OR CONCRETE OR BLOCK WALLS. ANCHORS CAN BE (BUT ARE NOT REQUIRED TO BE) COUNTERSUNK TO PROVIDE A FLUSH MOUNTING SURFACE. CONTINUOUS ANGLE TRACK CAN BE ANCHORED DIRECTLY TO GROUT REINFORCED BLOCK WALL OR 3,000 PSI MIN. CONCRETE COLUMN OR STEEL JAMBS.

2x6 JAMB TO SUPPORTING STRUCTURE ATTACHMENT
(NOT TO BE USED FOR ATTACHMENT OF TRACK ANGLE TO 2x6 VERTICAL JAMBS)

BUILDING TYPE	FASTENER TYPE	MAXIMUM ON-CENTER DISTANCE BETWEEN FASTENERS*	STEEL WASHERS REQUIRED
HOLLOW CMU BLOCK WALL	1/4" x 1-1/4" MIN. EMBED ULTRACON CONCRETE ANCHOR	4 1/2'	1' O.D.
GROUT-FILLED CMU BLOCK	1/4" x 1-1/4" MIN. EMBED ULTRACON CONCRETE ANCHOR	7 1/2'	1' O.D.
2000 PSI MIN. CONCRETE	1/4" x 1' MIN. EMBED ULTRACON CONCRETE ANCHOR	6 1/4'	1' O.D.
2000 PSI MIN. CONCRETE	1/4" x 1' MIN. EMBED TAPCON CONCRETE ANCHOR	6'	1' O.D.
2000 PSI MIN. CONCRETE	3/8" x 1-3/4" MIN. EMBED WEJ-IT ANKR TITE SLEEVE ANCHOR	13 1/2'	INCLUDED
4000 PSI MIN. CONCRETE	3/8" x 1-3/4" MIN. EMBED WEJ-IT ANKR TITE SLEEVE ANCHOR	24'	INCLUDED
WOOD FRAME (SYP 0.55 SG)	1/2" x 3" LAG SCREW (ASTM A307, GRADE A) 1-5/8" EMBED INTO STRUCTURE	14 3/4'	1' O.D.
14GA STEEL (0.060" MIN.)	1/4"-14 x 1" ITW BUILDDEX TEKS SELF-DRILLING FASTENER	6'	1' O.D.
12GA STEEL (0.105" MIN.)	1/4"-14 x 1" ITW BUILDDEX TEKS SELF-DRILLING FASTENER	10 3/4'	1' O.D.
1/8" STEEL	1/4"-14 x 1" ITW BUILDDEX TEKS SELF-DRILLING FASTENER	12 3/4'	1' O.D.

* FIRST (BOTTOM) ANCHOR STARTING AT NO MORE THAN HALF OF THE MAXIMUM ON-CENTER DISTANCE. HIGHEST ANCHOR INSTALLED AT LEAST AS HIGH AS THE DOOR OPENING.
CLOPAY DOES NOT SUPPLY JAMB ATTACHMENT FASTENERS.
MINIMUM DISTANCE BETWEEN CENTER OF ANCHOR AND EDGE OF CONCRETE: 2-1/2", EXCLUDING STUCCO THICKNESS. EXCEPTION FOR TAPCON --- MINIMUM EDGE DISTANCE FOR TAPCON FASTENER IS 1-1/4", EXCLUDING STUCCO THICKNESS.

OTHER JAMB CONFIGURATIONS: REFER TO DASMA TDS-161. A LICENSED DESIGN PROFESSIONAL MAY ALSO BE EMPLOYED TO APPROVE ALTERNATE FASTENERS AND/OR JAMB CONFIGURATIONS.

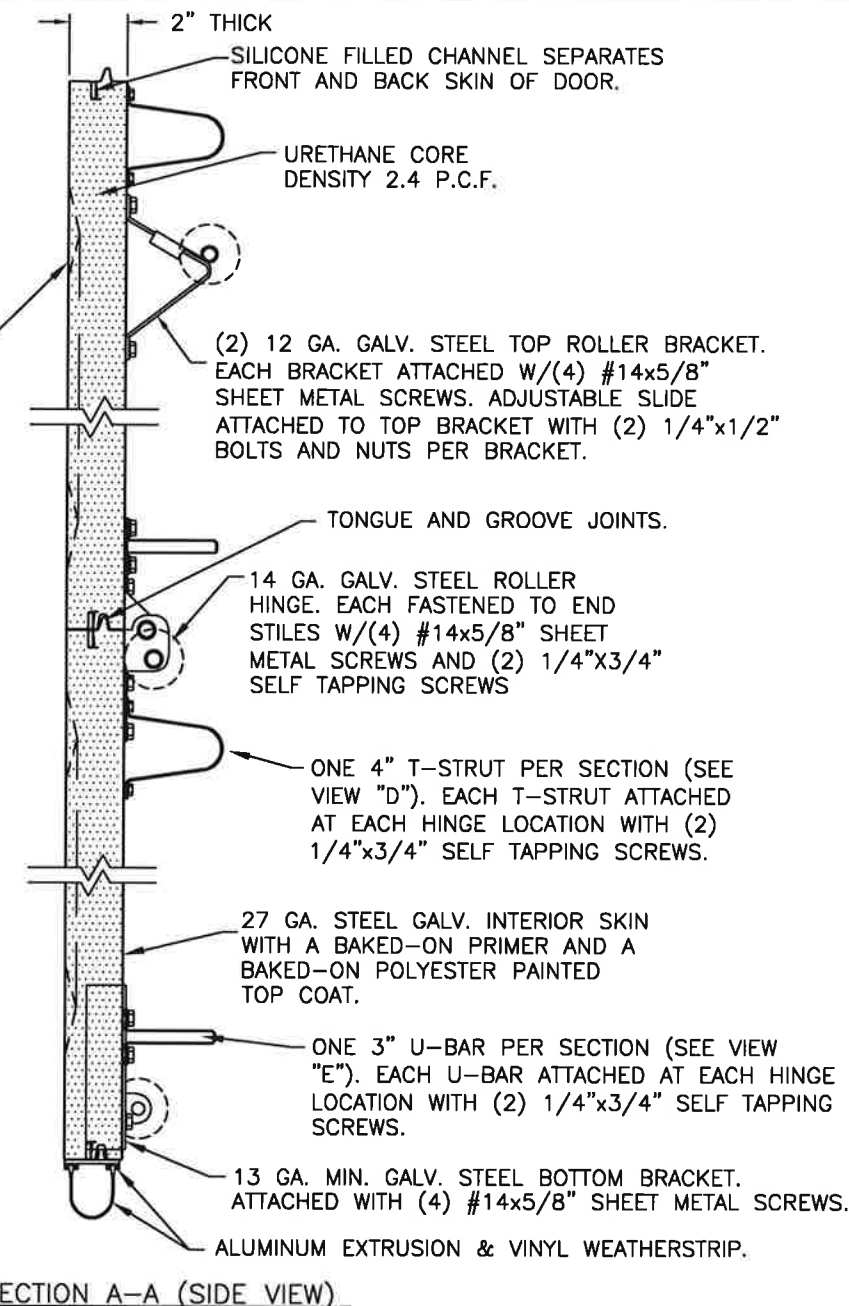
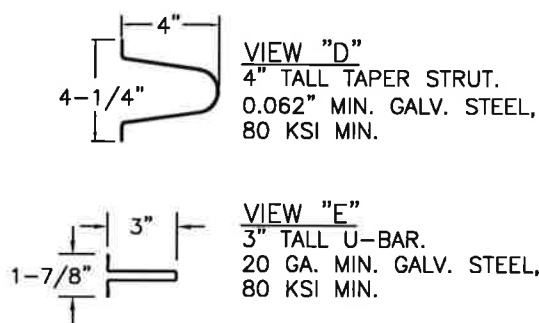

DESIGN LOADS: +46.0 P.S.F. & -52.0 P.S.F.
TEST LOADS: +69.0 P.S.F. & -78.0 P.S.F.

Unless Stated Otherwise TOLERANCES are
.0 = ±.031
.00 = ±.015
.000 = ±.005
.0000 = ±.001
Degrees = ±1/2"
Unless Stated Otherwise DIMENSIONS ARE IN INCHES.

Clopay CORPORATION
8585 Duke Boulevard
Mason, OH 45040 USA
Tel. No. 513-770-4800
Fax No. 513-770-4853

MANUFACTURING PRODUCT CODE
DSIUA-1F477
PART NO.: N/A
WINDLOAD RATING
W8 DP46T
DESCRIPTION: MODERN STEEL 2" INTELICORE +46/-52 PSF TO 16' W
DRAWN BY: SH DATE: 12/2015 SCALE: NTS DWG. B
CHECKED BY: -- DATE: -- SHEET 3 OF 5 SIZE B
DWG. NO.: 105002 VER: TDI

STATE OF TEXAS
MARK W. WESTERFIELD
11/22 91513
DESIGN ENGINEER
MARK WESTERFIELD, P.E.
FLORIDA P.E. #48495, NC P.E. #23832, TEXAS P.E. #91513

BRAND	MODERN STEEL		COMMERCIAL DOORS	
	FLUSH	GROOVED	FLUSH	GROOVED
CLOPAY	9208, HDPCC2	9209, HDPCR2	3728	3729
HOLMES	7208	7209	--	C7R20

SEE SHEET 5 FOR "CANYON RIDGE MODERN SERIES" MODELS.

SHEET: 4 OF 5	REVISIONS				
REV. NO.	ZONE:	DATE:	ECN NO.	APPVD:	DESCRIPTION
04	-	-	-	-	SEE REVISION HISTORY ON SHEET ONE.

2" TRACK CONFIGURATION.

NOTE DOUBLE TRACK HEADROOM, HI-LIFT TRACK, FOLLOW-THE-ROOF TRACK, AND VERTICAL LIFT TRACK ARE AVAILABLE OPTIONS. TRACK CONFIGURATION ABOVE THE DOOR OPENING DOES NOT AFFECT THE WIND LOAD RATING.

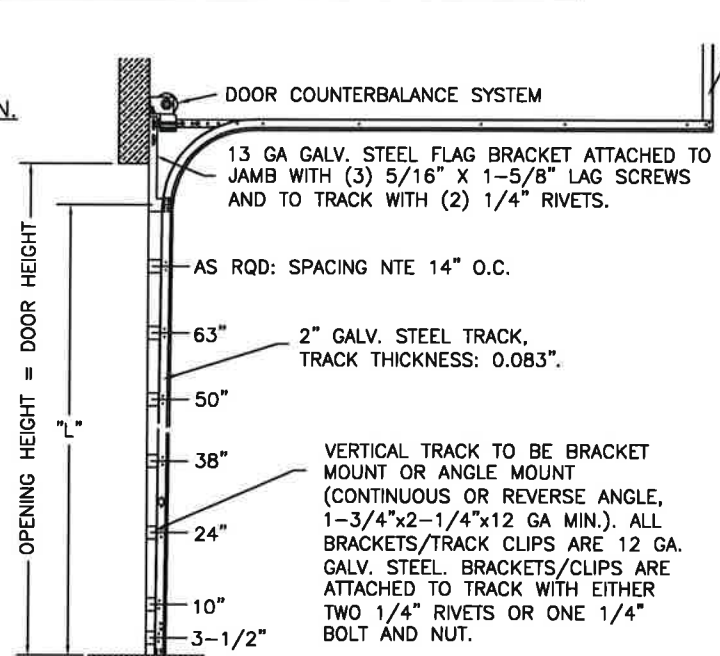

DOOR HEIGHT	"L"
6'-6"	70"
7'-0"	76"
7'-6"	82"
8'-0"	88"
8'-6"	94"
9'-0"	100"
9'-6"	106"
10'-0"	112"
10'-6"	118"
11'-0"	124"
11'-6"	130"
12'-0"	136"
12'-6"	142"
13'-0"	148"
13'-6"	154"
14'-0"	160"
14'-6"	166"
15'-0"	172"
15'-6"	178"
16'-0"	184"

BRACKET MOUNT JAMB CONFIGURATION

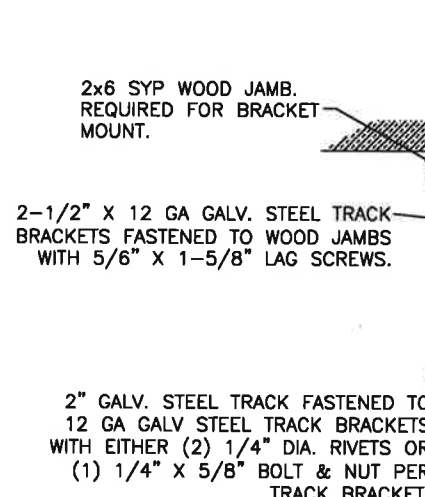

JAMB CONFIGURATION.

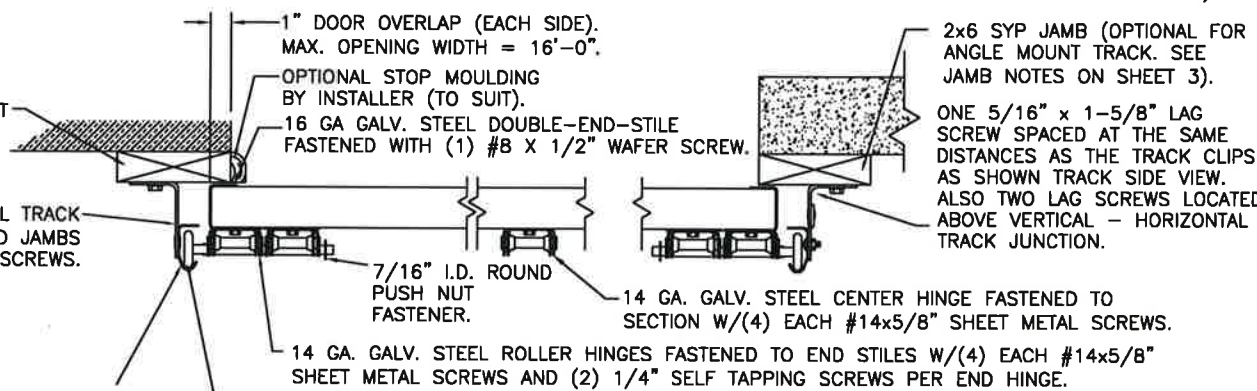

3" TRACK CONFIGURATION.

NOTE DOUBLE TRACK HEADROOM, HI-LIFT TRACK, FOLLOW-THE-ROOF TRACK, AND VERTICAL LIFT TRACK ARE AVAILABLE OPTIONS. TRACK CONFIGURATION ABOVE THE DOOR OPENING DOES NOT AFFECT THE WIND LOAD RATING.

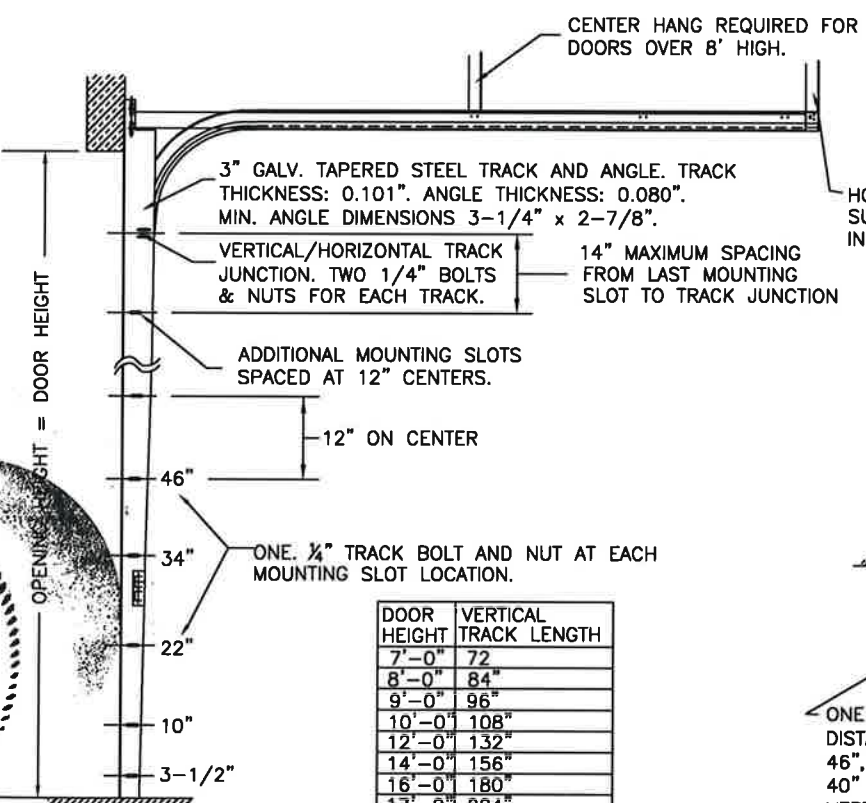

DOOR HEIGHT	VERTICAL TRACK LENGTH
7'-0"	72"
8'-0"	84"
9'-0"	96"
10'-0"	108"
12'-0"	132"
14'-0"	156"
16'-0"	180"
17'-0"	204"
18'-0"	228"

JAMB CONFIGURATION FOR 3" TRACK.

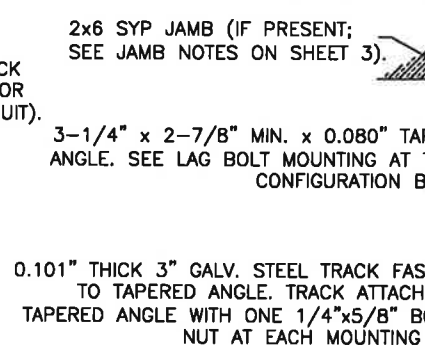

SECTION C-C PREPARATION OF JAMBS BY OTHERS.

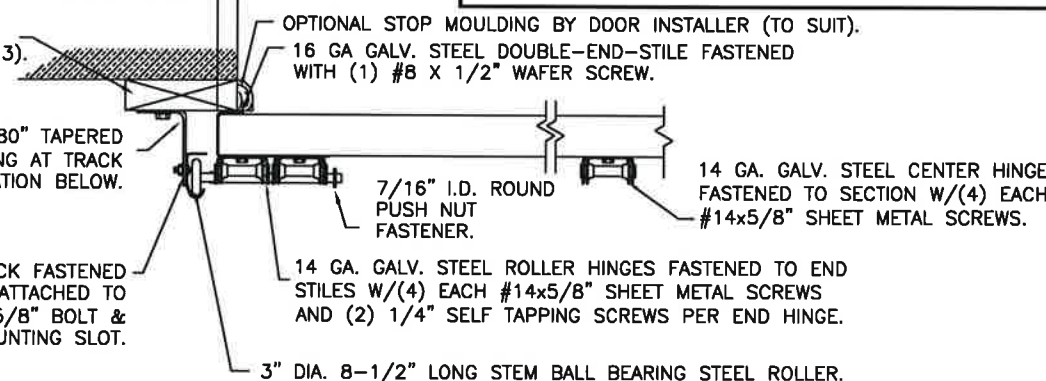

SECTION C-C PREPARATION OF JAMBS BY OTHERS.

DESIGN LOADS: +46.0 P.S.F. & -52.0 P.S.F.
TEST LOADS: +69.0 P.S.F. & -78.0 P.S.F.

Unless Stated Otherwise TOLERANCES are
.0 = ±.031
.00 = ±.015
.000 = ±.005
.0000 = ±.001
Degrees = ±1/2"
Unless Stated Otherwise DIMENSIONS ARE IN INCHES.

Glopay CORPORATION
8585 Duke Boulevard
Mason, OH 45040 USA
Tel. No. 513-770-4800
Fax No. 513-770-4853

MANUFACTURING PRODUCT CODE
DSIUA-1F477

PART NO.: N/A

WINDLOAD RATING
W8 DP46T

DESCRIPTION: MODERN STEEL 2" INTELICORE +46/-52 PSF TO 16' W

DRAWN BY: SH DATE: 12/2015 SCALE: NTS DWG. B

CHECKED BY: -- DATE: -- SHEET 4 OF 5 SIZE B

DWG. NO.: 105002 VER: TDI

STATE OF TEXAS
MARK W. WESTERFIELD
P.E. #2291513
DESIGN ENGINEER
MARK WESTERFIELD, P.E.
FLORIDA P.E. #48495, NC P.E. #23832, TEXAS P.E. #91513

CLOPAY 'CANYON RIDGE MODERN SERIES': CRM2nnn

HOLMES 'GLENMOOR MODERN SERIES': GLM2nnn

IDEAL 'CUSTOM CRAFTED MODERN WOOD-LOOK' SERIES: WLM2nnn

NOTE: "nnn" REPRESENTS THE ARRANGEMENT OF THE DECORATIVE OVERLAYS. DOORS MAY HAVE 'PLANK' APPEARANCE, ALUMINUM INLAYS, OR "FULL VISION".

SHEET: 5 OF 5		REVISIONS			
REV. NO.	ZONE:	DATE:	ECN NO.	APPVD:	DESCRIPTION
04	-	-	-	-	SEE REVISION HISTORY ON SHEET ONE.

FULL VISION GLAZING SHOWN.

OPTIONAL IMPACT RESISTANT GLAZING. MAXIMUM GLAZING SIZE (DLO) IS 39-1/4"x13-1/4". GLAZING MAY BE FULL VISION, SHORT-PLANK OR LONG-PLANK. SEE SECTION B-B ON SHEET 5 FOR IMPACT RESISTANT DETAILS OR SECTION B-B ON SHEET 2 STANDARD CONSTRUCTION. GLAZING MAY BE INSTALLED IN ANY LOCATION IN ANY OR ALL SECTIONS.

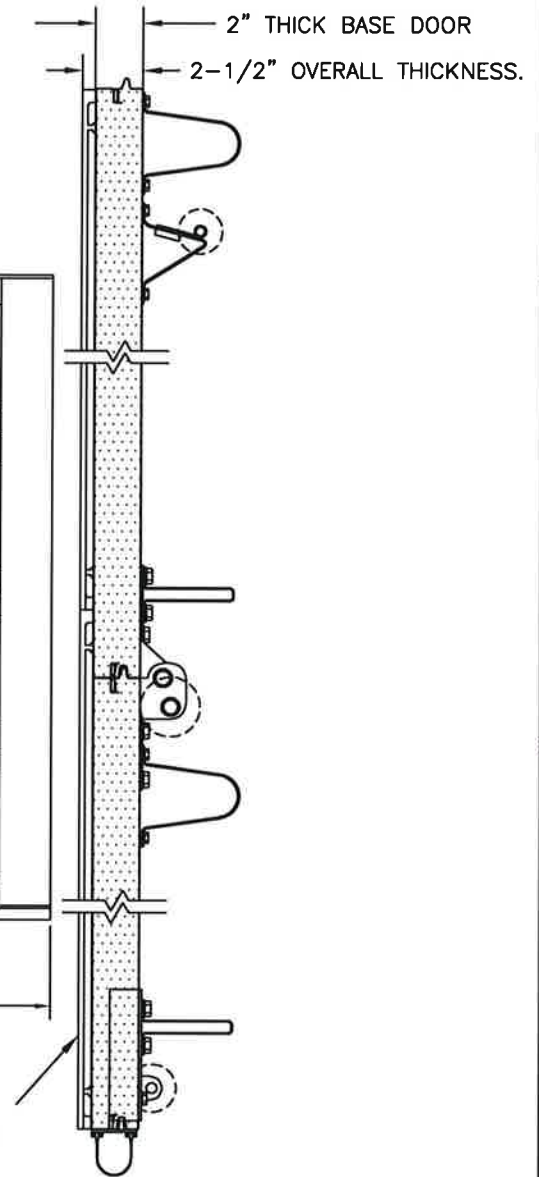

SECTION A-A (SIDE VIEW)

SECTION B-B (CANYON RIDGE TYPE IMPACT-RESISTANT GLAZING OPTION)

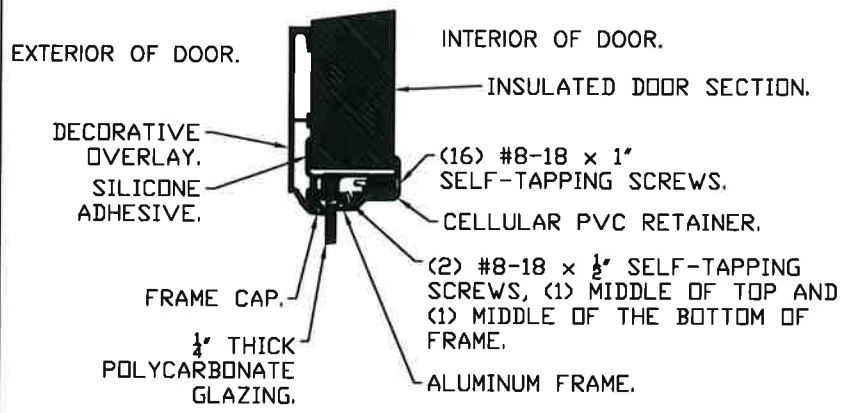

NOTE: THE (16) SELF-TAPPING SCREWS ARE ARRANGED WITH (5) SCREWS ON EACH HORIZONTAL EDGE AND (3) ON EACH VERTICAL EDGE.

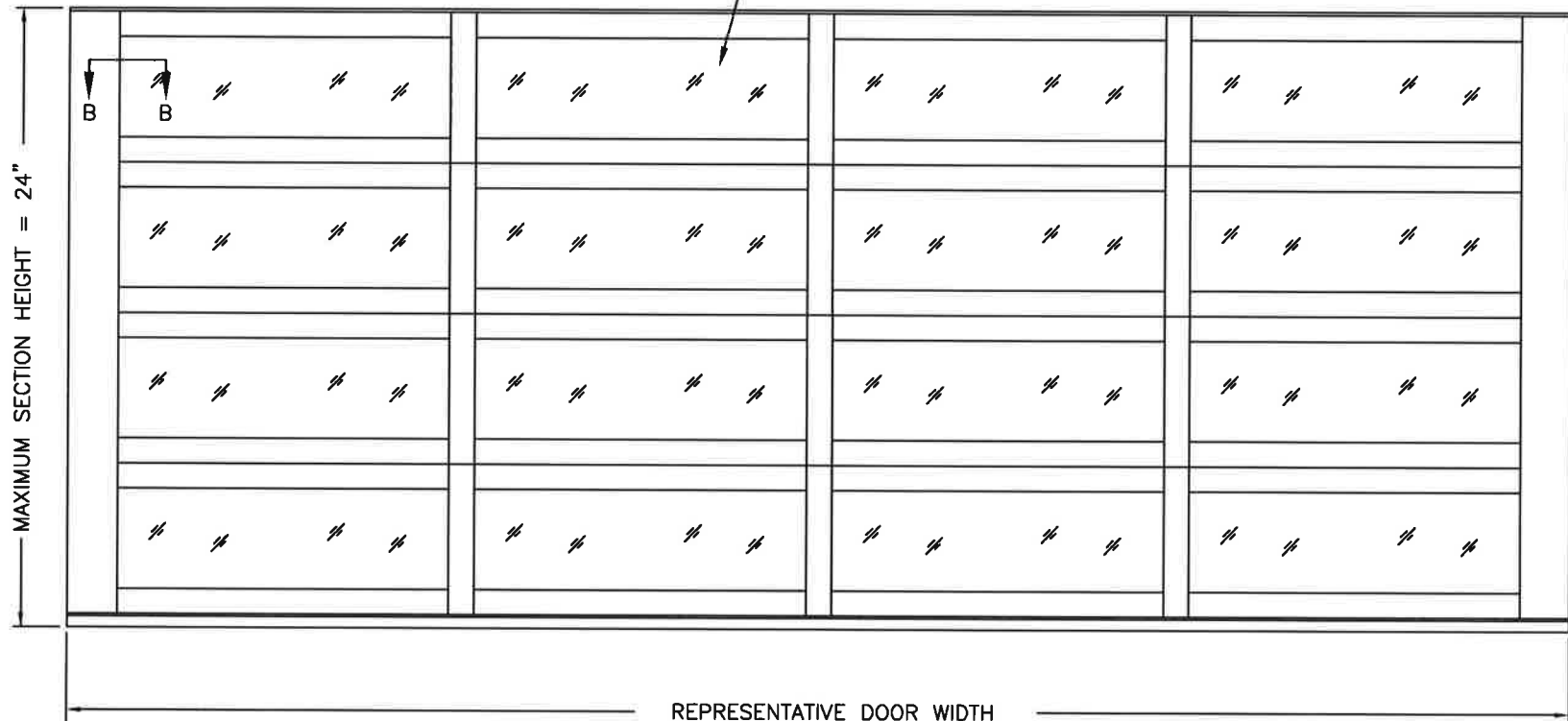

"CANYON RIDGE" TYPE OVERLAY DOORS

- NOTES:
- "CANYON RIDGE" TYPE DOORS USE THE SAME REINFORCEMENTS AND BASE SECTION CONSTRUCTION AND TRACK CONFIGURATION DESCRIBED ON SHEETS 1-4 OF THIS DRAWING.
 - "CANYON RIDGE" TYPE DOORS ARE IMPACT RESISTANT WITH IMPACT RESISTANT GLAZING AND FRAME AS SHOWN IN DETAIL B-B ABOVE.

REPRESENTATIVE GLAZING PATTERNS.

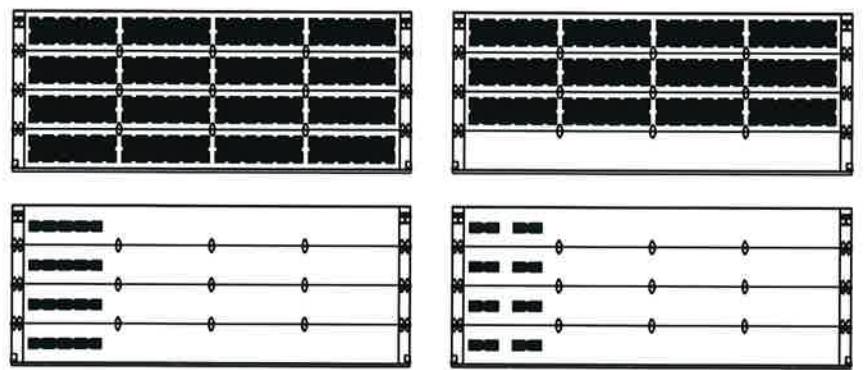

GLAZING MAY BE IN ANY LOCATION IN ANY OR ALL SECTIONS. THESE PATTERNS ARE REPRESENTATIVE OF THE APPROVED CONFIGURATIONS. NOT ALL CONFIGURATIONS ARE AVAILABLE AS STANDARD PRODUCT. CONSULT FACTORY FOR DETAILS.

CANYON-RIDGE TYPE MODERN SERIES: HIGH DENSITY MOLDED COMPOSITE CLADDING OR OVERLAYS ADHERED TO OUTSIDE SKIN WITH PERMANENT ADHESIVE.

DESIGN LOADS: +46.0 P.S.F. & -52.0 P.S.F.
TEST LOADS: +69.0 P.S.F. & -78.0 P.S.F.

Unless Stated Otherwise
TOLERANCES are

.0 = ±.031
.00 = ±.015
.000 = ±.005
.0000 = ±.001
Degrees = ±1/2'

Unless Stated Otherwise
DIMENSIONS ARE IN INCHES.

Clopay CORPORATION
8585 Duke Boulevard
Mason, OH 45040 USA
Tel. No. 513-770-4800
Fax No. 513-770-4853

DESCRIPTION: MODERN STEEL 2" INTELICORE +46/-52 PSF TO 16' W
DRAWN BY: SH DATE: 12/2015
CHECKED BY: -- DATE: --
DWG. NO.: 105002

MANUFACTURING PRODUCT CODE DSIUD-1K479	
PART NO.: N/A	
WINDLOAD RATING W8 DP46T	
SCALE: NTS	DWG. B
SHEET 5 OF 5	SIZE B
VER: TDI	

STATE OF TEXAS
MARK WESTERFIELD
REGISTERED PROFESSIONAL ENGINEER
91513
11/1/12

DESIGN ENGINEER
MARK WESTERFIELD, P.E.
FLORIDA P.E. #48495, NC P.E. #23832, TEXAS P.E. #91513