

DOOR HEIGHT	NUMBER OF SECTIONS REQD.	
	21" SECTIONS	24" SECTIONS
5'-3"	3	0
7'-0"	4	0
7'-6"	2	2
8'-0"	0	4
8'-9"	5	0
9'-0"	4	1
10'-0"	0	5
11'-0"	4	2
12'-0"	0	6
13'-0"	4	3
14'-0"	0	7
7'-9"	1	3
9'-3"	3	2
9'-6"	2	3
10'-6"	6	0
10'-9"	5	1
11'-6"	2	4
11'-9"	1	5
12'-6"	6	1
12'-9"	5	2

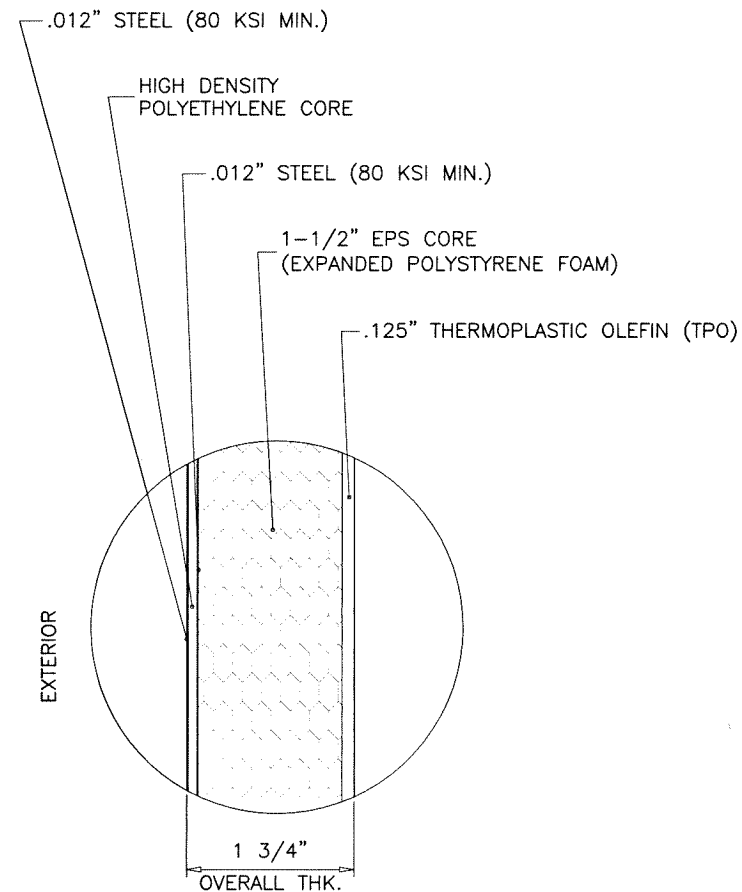

COMPOSITE SECTION DETAIL
EXTERIOR FINISHES HIGH GLOSS POLYSTER PAINT

THESE DOORS ARE NOT RATED FOR IMPACT.
INSTALLATION OF THIS SYSTEM OUTSIDE WIND BORNE DEBRIS PROTECTION AREA SHALL MEET THE APPLICABLE REQUIREMENTS.

DESIGN IS BASED ON TESTING IN ACCORDANCE WITH THE 2018 IRC/IBC AND 2020 FLORIDA BUILDING CODE.
STATIC AIR PRESSURE TEST, TAS 202-94

**Series 'DuraFlex' (18'-2")
Sectional Garage Door**

THIS PRODUCT HAS BEEN DESIGNED AND TESTED TO COMPLY WITH THE REQUIREMENTS OF THE 2018 INTERNATIONAL RESIDENTIAL CODE (IRC) AND 2018 INTERNATIONAL BUILDING CODE (IBC).

WOOD BUCKS & BUCK FASTENERS BY OTHERS, MUST BE DESIGNED AND INSTALLED ADEQUATELY TO TRANSFER APPLIED PRODUCT LOADS TO THE BUILDING STRUCTURE.

ANCHORS SHALL BE CORROSION RESISTANT, SPACED AS SHOWN ON DETAILS AND INSTALLED PER MANUF'S INSTRUCTIONS. SPECIFIED EMBEDMENT TO BASE MATERIAL SHALL BE BEYOND WALL DRESSING OR STUCCO.

A LOAD DURATION INCREASE IS USED IN DESIGN OF ANCHORS INTO WOOD ONLY.

MATERIALS INCLUDING BUT NOT LIMITED TO STEEL/METAL SCREWS, THAT COME INTO CONTACT WITH OTHER DISSIMILAR MATERIALS SHALL MEET THE REQUIREMENTS OF THE 2018 IRC/IBC.

THIS PRODUCT APPROVAL IS GENERIC AND DOES NOT PROVIDE INFORMATION FOR A SITE SPECIFIC PROJECT, i.e. LIFE SAFETY OF THIS PRODUCT, ADEQUACY OF STRUCTURE RECEIVING THIS PRODUCT AND SEALING AROUND OPENING FOR WATER INFILTRATION RESISTANCE ETC.

CONDITIONS NOT SHOWN IN THIS DRAWING ARE TO BE ANALYZED SEPARATELY, AND TO BE REVIEWED BY BUILDING OFFICIAL.

DESIGN LOADS SHOWN ARE BASED ON 'ALLOWABLE STRESS DESIGN (ASD)'.
MANUFACTURER'S LABEL SHALL BE LOCATED ON A READILY VISIBLE LOCATION IN ACCORDANCE WITH SECTIONS R613.4 AND R613.7.1 OF THE IRC AND SECTION 1714.5.1 OF THE IBC.

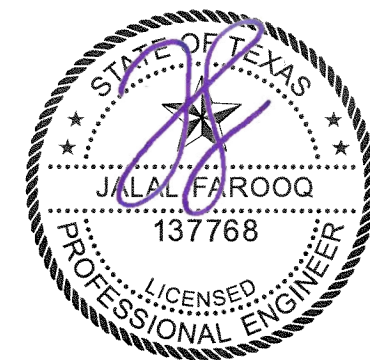

5/18/2021

af c
AL-FAROOQ CORPORATION
ENGINEERS & PRODUCT DEVELOPMENT
9360 SUNSET DRIVE, SUITE 220
MIAMI, FLORIDA 33173 (C.A.N. 3538)
TEL. (305) 264-8100 FAX. (305) 262-6978
GARAGE 21-19T-DSC

DuraFlex 18'-2" Sectional Garage Door (N.I.)
DuraServ Corp.
11431 Ferrell Drive, Suite 200
Farmers Branch, TX 75234
Tel: (800) 994-2361 Fax: (-)

no	date	by	description

date: 03-11-21
scale: 1/2" = 1"
dr. by: TARIQ
chk. by:

drawing no.
21-19T
sheet 1 of 6

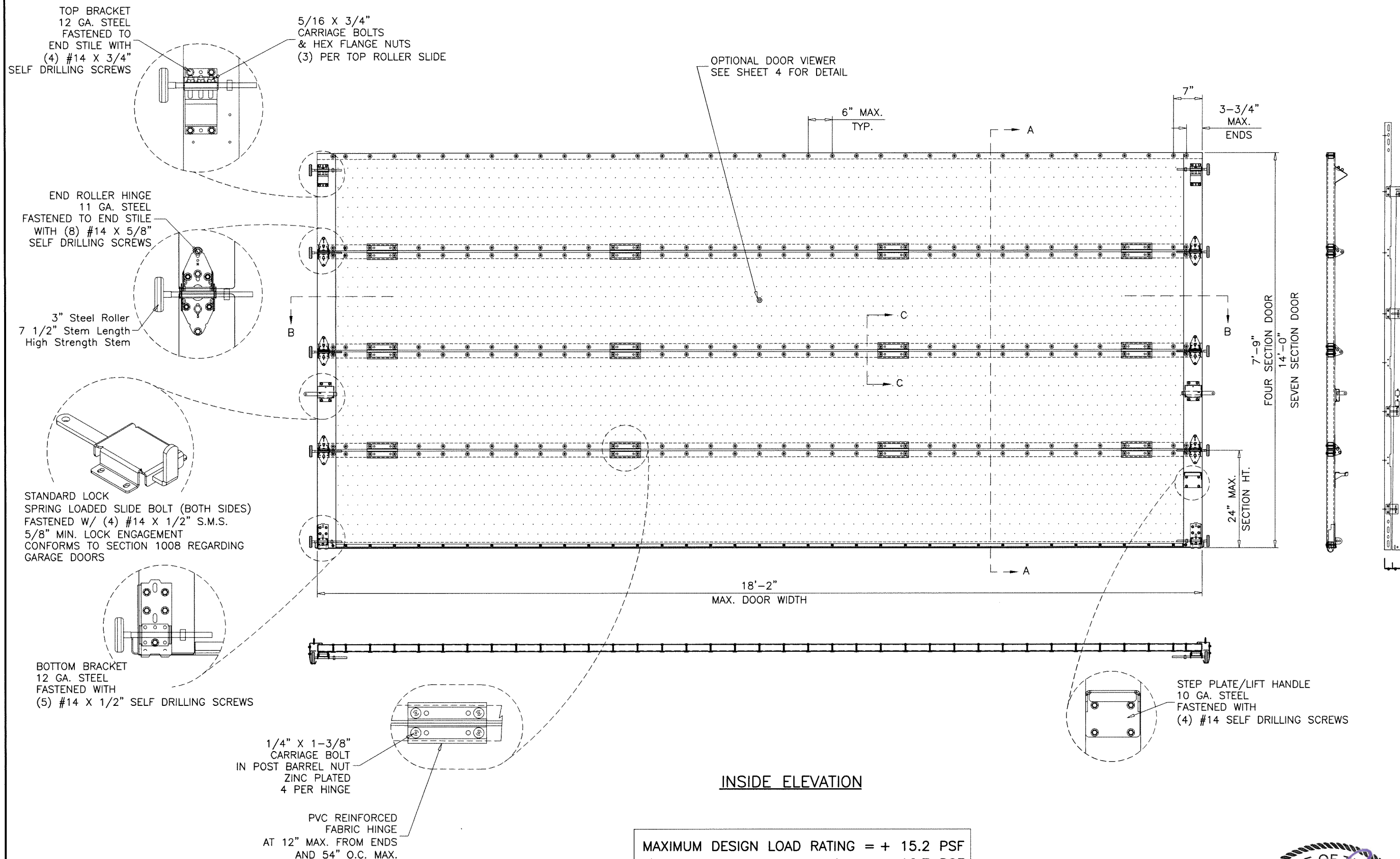

INSIDE ELEVATION

MAXIMUM DESIGN LOAD RATING = + 15.2 PSF
 (FOR DOOR SIZE SHOWN OR SMALLER) - 16.7 PSF

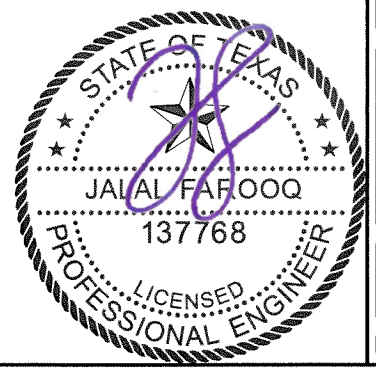

5/18/2021

af c
AL-FAROOQ CORPORATION
 ENGINEERS & PRODUCT DEVELOPMENT
 9360 SUNSET DRIVE, SUITE 220
 MIAMI, FLORIDA 33173 (C.A.N. 3538)
 TEL. (305) 264-8100 FAX. (305) 262-6978
 GARAGE 21-19T-DSC

DuraFlex 18'-2" Sectional Garage Door (N.I.)
DuraServ Corp.
 11431 Ferrell Drive, Suite 200
 Farmers Branch, TX 75234
 Tel: (800) 994-2361 Fax: (-)

revisions:	no	date	by	description

date: 03-11-21
 scale: 1/2"=1'-0"
 dr. by: TARIQ
 chk. by:

drawing no.
21-19T

sheet 2 of 6

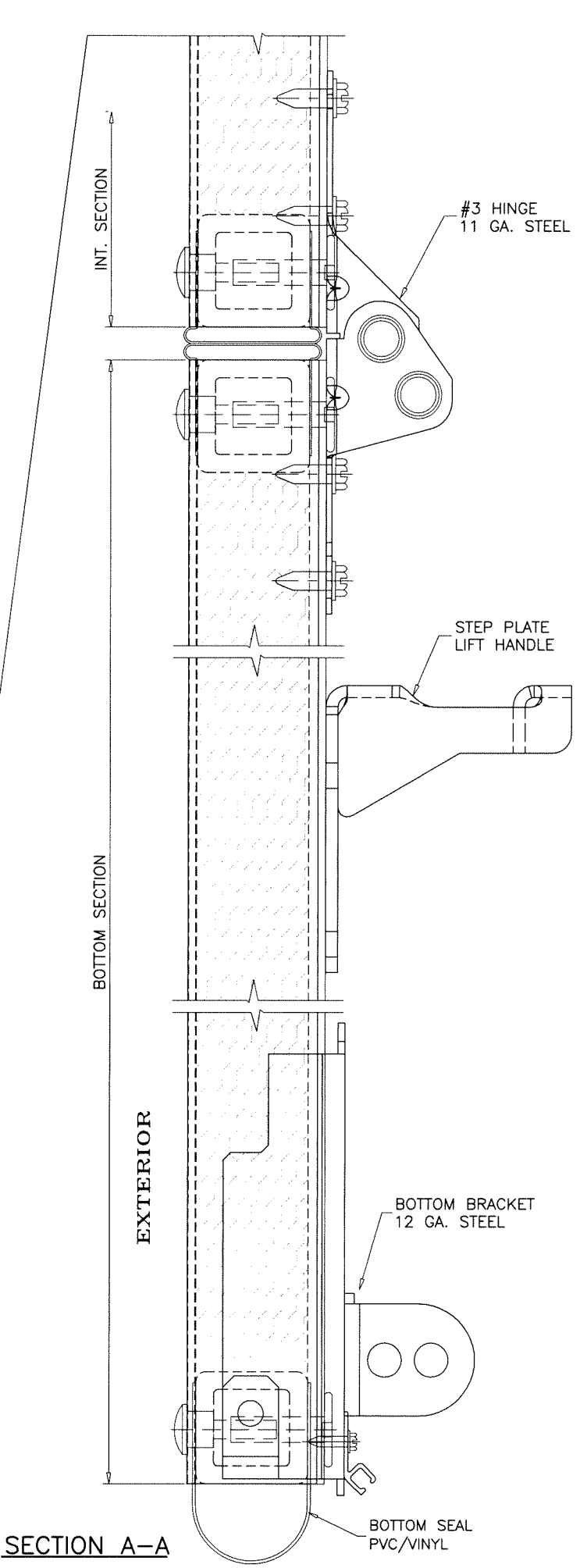
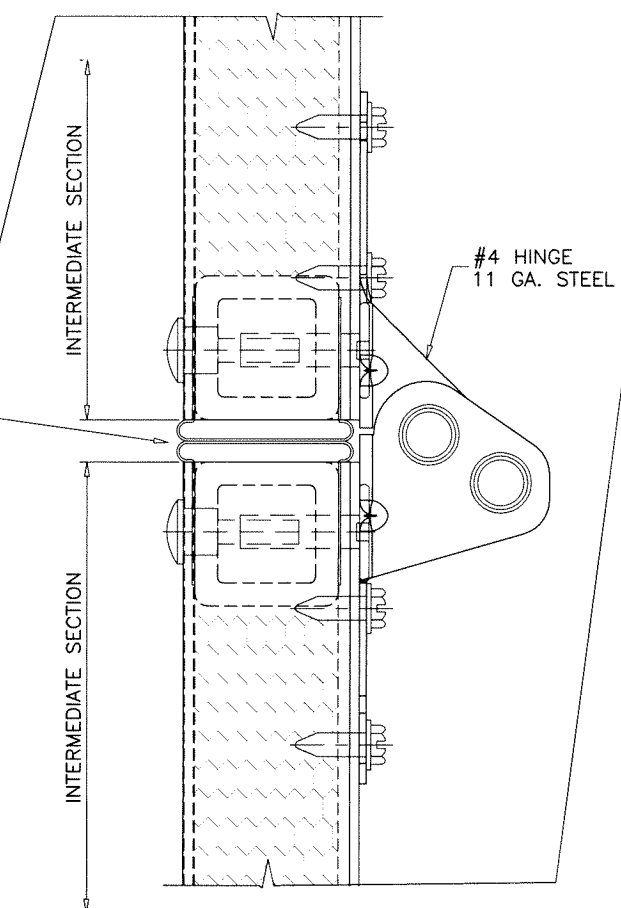
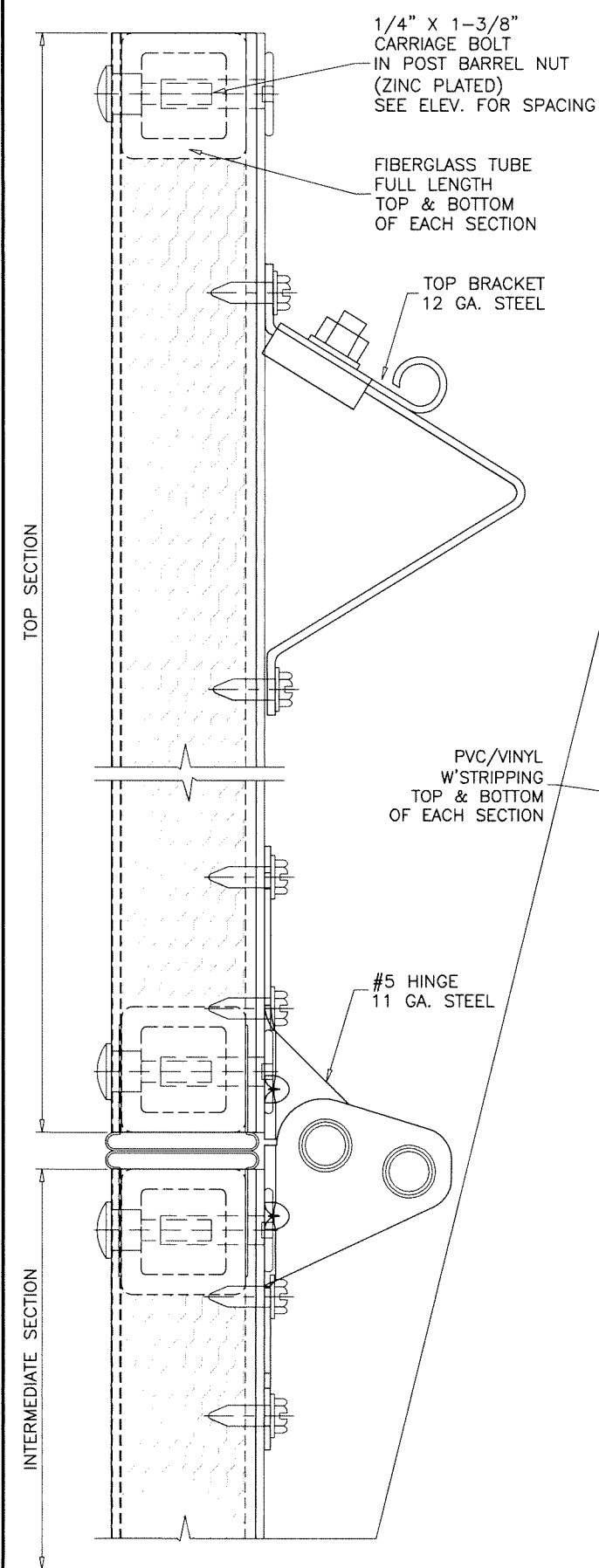

SECTION A-A

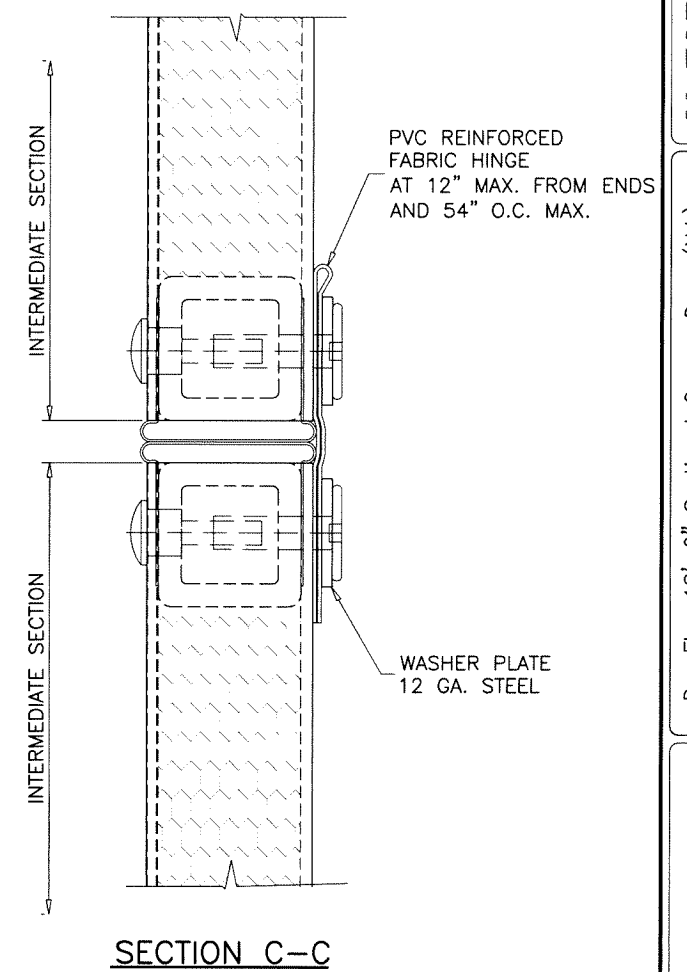

SECTION C-C

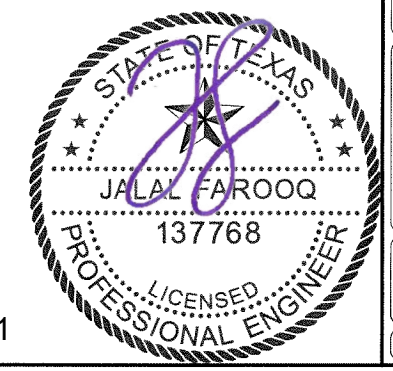

5/18/2021

af c
AL-FAROOQ CORPORATION
 ENGINEERS & PRODUCT DEVELOPMENT
 9360 SUNSET DRIVE, SUITE 220 (C.A.N. 3538)
 MIAMI, FLORIDA 33173
 TEL. (305) 264-8100 FAX. (305) 262-6978
 GARAGE 21-19T-DSC

DuraFlex 18'-2" Sectional Garage Door (N.I.)
DuraServ Corp.
 11431 Ferrell Drive, Suite 200
 Farmers Branch, TX 75234
 Tel: (800) 994-2361 Fax: (-)

revisions:	
no	date by description

date: 03-11-21
 scale: 1/2" = 1"
 dr. by: TAR/Q
 chk. by:

drawing no.
21-19T
 sheet 3 of 6

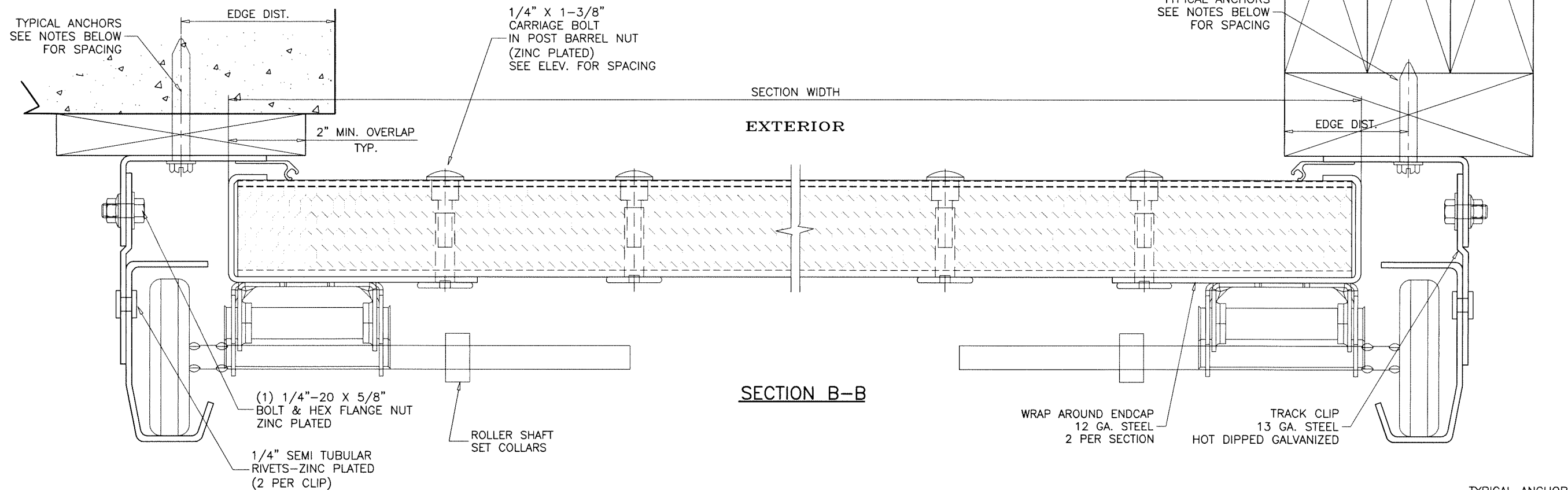

TYPICAL ANCHORS:

5/16" DIA. ULTRACON BY 'DEWALT' (Fu=177 KSI, Fy=155 KSI)

THRU 1BY OR 2BY BUCKS INTO CONCRETE
 1-3/4" MIN. EMBED INTO CONCRETE
 AT 4" FROM BOTTOM AND 6" O.C. MAX.

DIRECTLY INTO CONCRETE
 1-3/4" MIN. EMBED INTO CONCRETE
 AT 4" FROM BOTTOM AND 12" O.C. MAX.

3/8" DIA. KWIK BOLT-3 EXPANSION ANCHOR BY 'HILTI'

DIRECTLY INTO MASONRY
 2-1/2" MIN. EMBED INTO GROUT-FILLED BLOCKS
 AT 4" FROM BOTTOM AND 6" O.C. MAX.
 4" MIN. EDGE DISTANCE

5/16" DIA. DRIL-FLEX SELF DRILLING SCREWS BY 'DEWALT' (GRADE 5 CRS)

INTO METAL STRUCTURES
 AT 4" FROM BOTTOM AND 12" O.C. MAX.
 STEEL: 1/8" THK. MIN. (Fy = 36 KSI MIN.)
 (STEEL IN CONTACT WITH ALUMINUM TO BE PLATED OR PAINTED)

5/16" DIA. LAG SCREWS

INTO WOOD STRUCTURES
 2" MIN. PENETRATION INTO WOOD
 AT 4" FROM BOTTOM AND 6" O.C. MAX.

TYPICAL EDGE DISTANCE

INTO CONCRETE = 2-3/16" MIN.
 INTO FILLED BLOCKS = 4" MIN.
 INTO WOOD STRUCTURE = 1-1/2" MIN.
 INTO METAL STRUCTURE = 3/4" MIN.

WOOD SG = 0.55 MIN.
 CONCRETE f'c = 3000 PSI MIN.
 C-90 GROUT FILLED BLOCK f'm = 2000 PSI MIN.

SECTION B-B

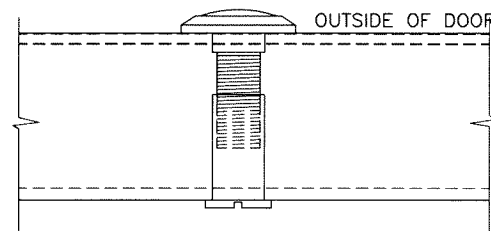
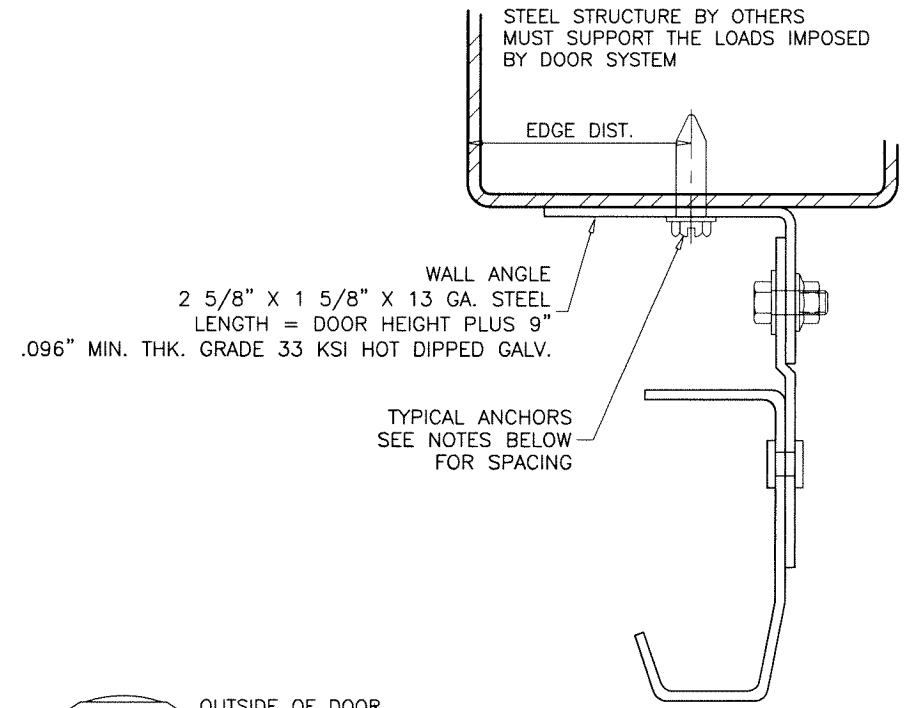

SOLID BRASS DOOR VIEWER
 BY 'SCHLAGE SECURITY HARDWARE'
 INSTALLED IN 9/16" DIA. HOLES
 POSITIONED AT EYE LEVEL

af c
AL-FAROOQ CORPORATION
 ENGINEERS & PRODUCT DEVELOPMENT
 9360 SUNSET DRIVE, SUITE 220 (C.A.N. 3538)
 MIAMI, FLORIDA 33173
 TEL. (305) 262-6978
 FAX. (305) 264-8100

DuraFlex 18'-2" Sectional Garage Door (N.I.)
DuraServ Corp.
 11431 Ferrell Drive, Suite 200
 Farmers Branch, TX 75234
 Tel: (800) 994-2361 Fax: (-)

revisions:	no	date	by	description

date: 03-11-21
 scale: 1/2" = 1"
 dr. by: TARIQ
 chk. by:

drawing no.
21-19T
 sheet 4 of 6

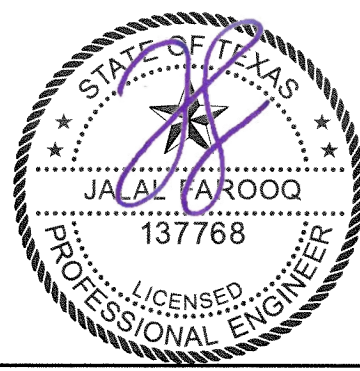

5/18/2021

GARAGE\21-19T-DSC

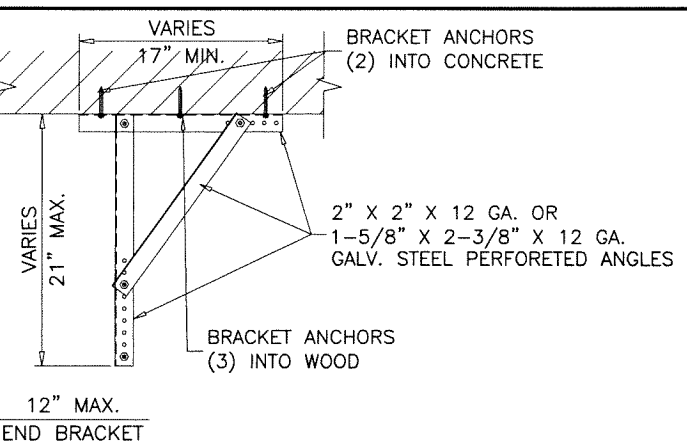
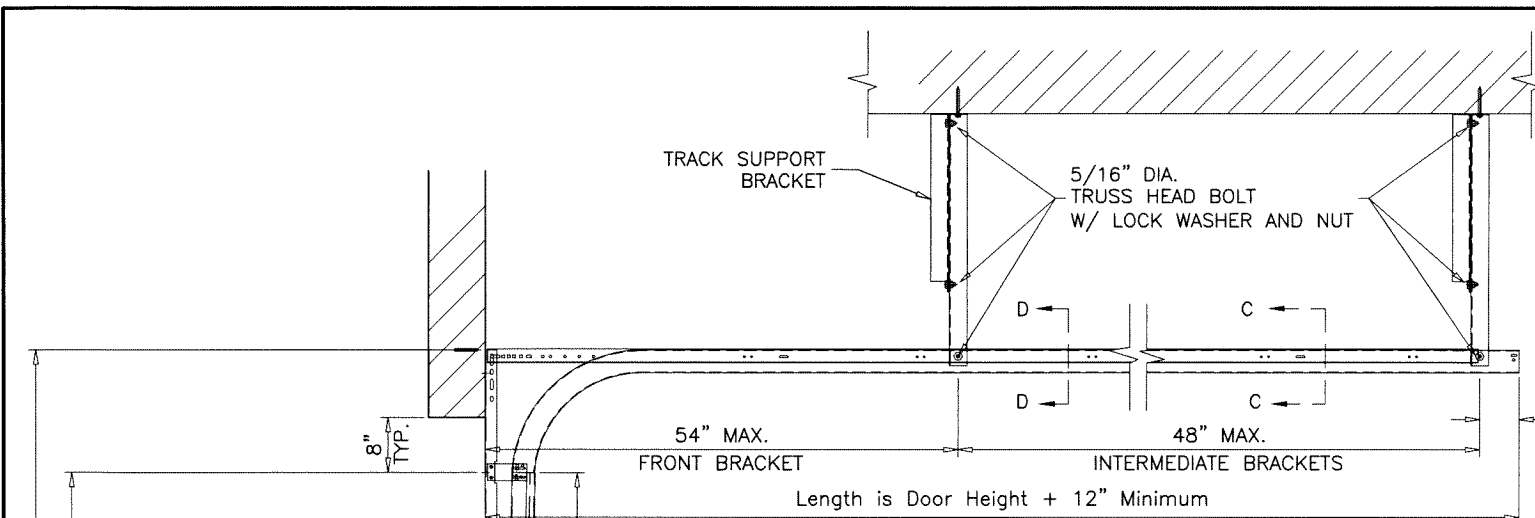

NOTE:
IT SHALL BE VERIFIED THAT THE CEILING STRUCTURE CAN SUSTAIN LOADS IMPOSED BY DOOR WHEN LEFT IN OPEN POSITION.
BRACES MAY BE MOVED IN ORDER TO ENGAGE THE CEILING STRUCTURE.
ANCHOR EMBEDMENT TO BASE MATERIAL SHALL BE BEYOND ALL CEILING NON STRUCTURAL MATERIAL STUCCO OR CEILING DRESSING.

SUPPORT BRACKETS AT EACH TRACK

BRACKETS RUN PERPENDICULAR TO TRACKS
FRONT AND END BRACKETS TO BE SPACED AS SHOWN ABOVE.
ADDITIONAL INTERMEDIATE BRACKETS TO BE INSTALLED FOR SPACING MORE THAN 48" IN BETWEEN FRONT AND END BRACKETS.

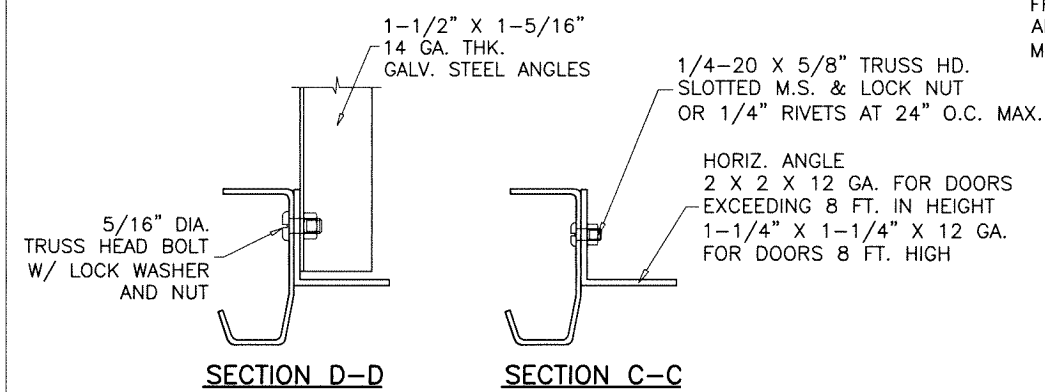

BRACKET ANCHORS:

(3) 5/16" DIA. LAG SCREWS
INTO WOOD STRUCTURES, (S.G.=0.50)
1-1/2" MIN. PENETRATION
(2) 1/4" DIA. ULTRACON+ BY 'DEWALT' (Fu=164 KSI, Fy=148 KSI)
INTO CONCRETE, 3000 PSI MIN.
1-3/4" MIN. EMBED
ANCHORING TO CEILING OTHER THAN WOOD OR CONCRETE TO BE REVIEWED SEPARATELY.

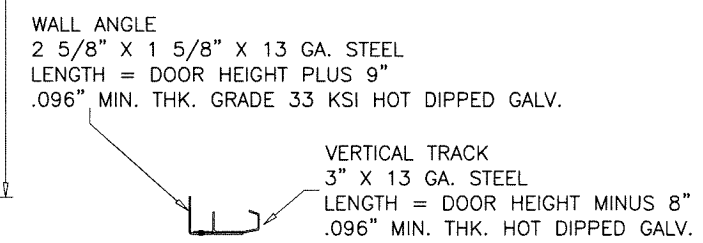
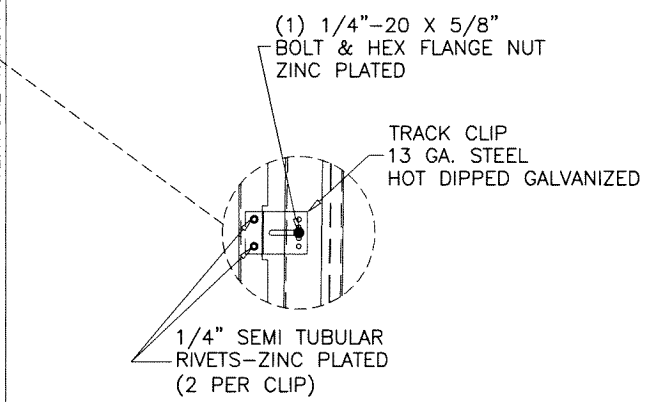
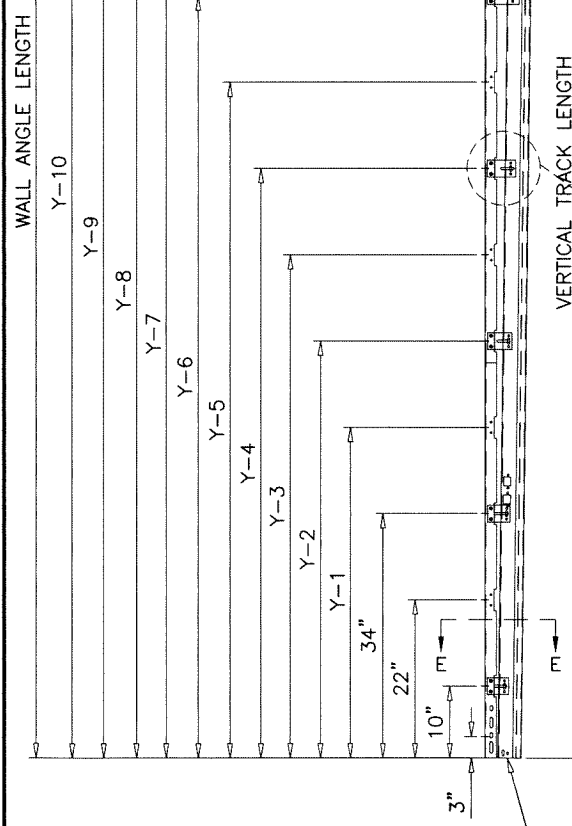

DOOR HEIGHT	VERTICAL TRACK LENGTH	WALL ANGLE LENGTH	TRACK CLIP & ANCHOR SPACING											
			Y-1	Y-2	Y-3	Y-4	Y-5	Y-6	Y-7	Y-8	Y-9	Y-10		
5' 3"	55"	72"	44"	55"	70"	NA	NA	NA	NA	NA	NA	NA	NA	NA
7' 0"	76"	93"	46"	58"	67"	76"	NA	NA	NA	NA	NA	NA	NA	NA
7' 6"	82"	99"	46"	58"	70"	82"	NA	NA	NA	NA	NA	NA	NA	NA
8' 0"	88"	105"	46"	58"	73"	88"	NA	NA	NA	NA	NA	NA	NA	NA
8' 9"	97"	114"	46"	58"	70"	82"	97"	NA	NA	NA	NA	NA	NA	NA
9' 0"	100"	117"	46"	58"	70"	82"	91"	100"	NA	NA	NA	NA	NA	NA
10' 0"	112"	129"	46"	58"	70"	82"	97"	112"	NA	NA	NA	NA	NA	NA
11' 0"	124"	141"	46"	58"	70"	82"	94"	106"	151"	124"	NA	NA	NA	NA
12' 0"	136"	153"	46"	58"	70"	82"	94"	106"	121"	136"	NA	NA	NA	NA
13' 0"	148"	165"	46"	58"	70"	82"	94"	106"	118"	130"	139"	148"	NA	NA
14' 0"	160"	177"	46"	58"	70"	82"	94"	106"	118"	130"	145"	160"	NA	NA

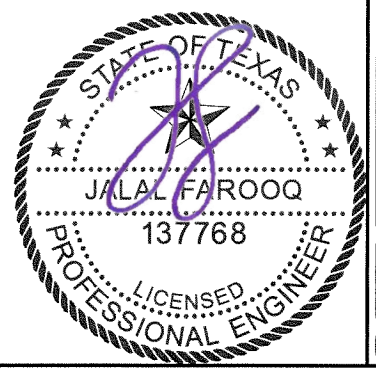
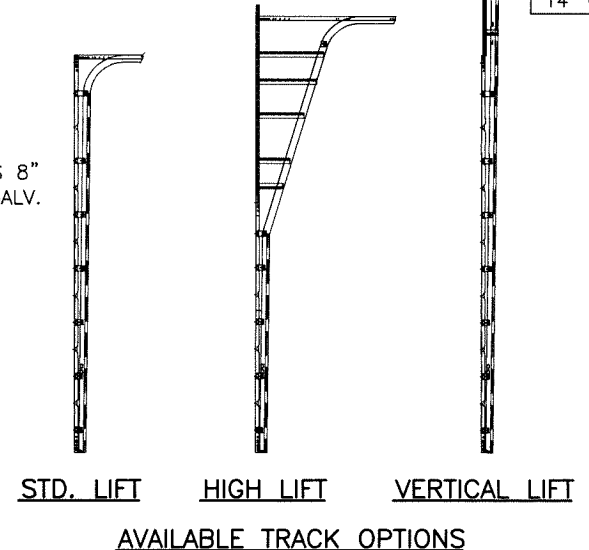

AL-FAROOQ CORPORATION
ENGINEERS & PRODUCT DEVELOPMENT
9360 SUNSET DRIVE, SUITE 220
MIAMI, FLORIDA 33173
TEL. (305) 264-8100 FAX. (305) 262-6978
(C.A.N. 3538)

DuraFlex 18'-2" Sectional Garage Door (N.I.)
DuraServ Corp.
11431 Ferrell Drive, Suite 200
Farmers Branch, TX 75234
Tel: (800) 994-2361 Fax: (-)

revisions:	no	date	by	description

date: 03-11-21
scale: -
dr. by: TARIQ
chk. by:

drawing no.
21-19T
sheet 5 of 6

5/18/2021

GARAGE\21-19T-DSC

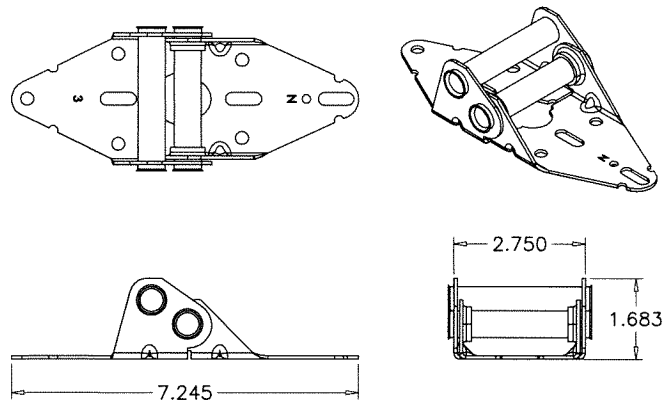

#3 HINGE (11 GA. STEEL)

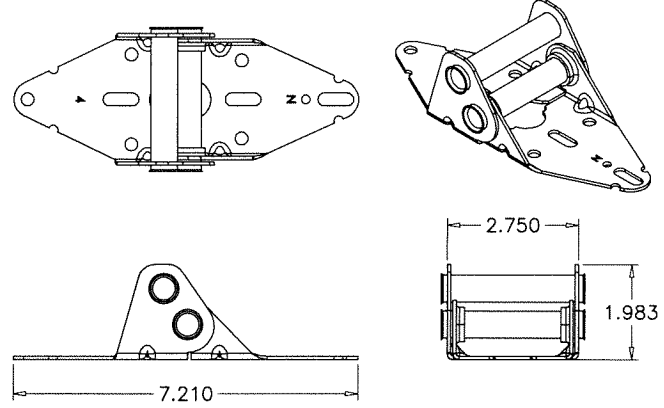

#4 HINGE (11 GA. STEEL)

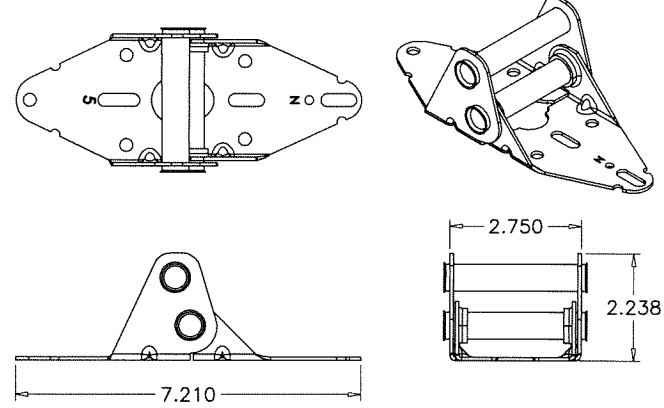

#5 HINGE (11 GA. STEEL)

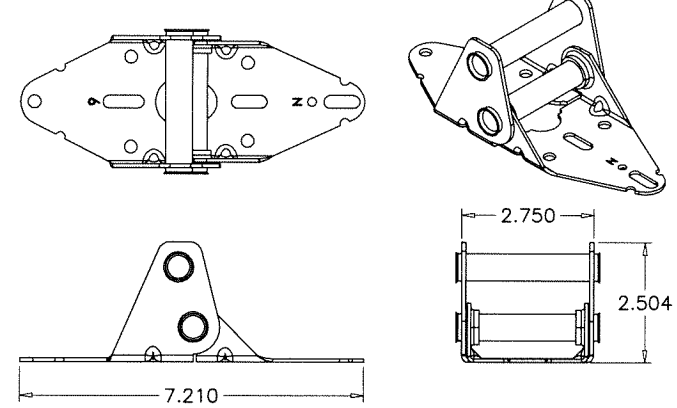

#6 HINGE (11 GA. STEEL)

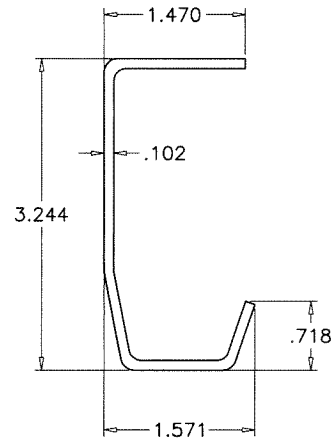

TRACK
13 GA. STEEL
SCALE 1/2" = 1"

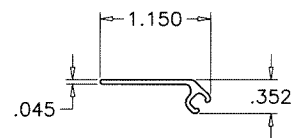

SEAL RETAINER
6063-T6
SCALE 1/2" = 1"

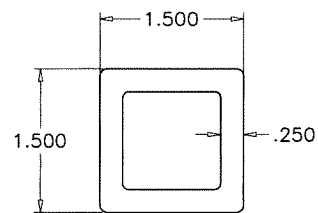

SECTION TOP/BOTTOM TUBE
PULTRUDED FIBERGLASS
SCALE 1/2" = 1"

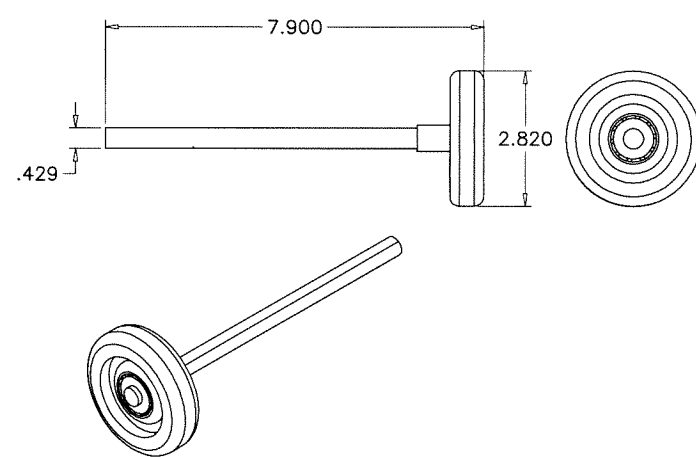

HURRICANE ROLLER-DF

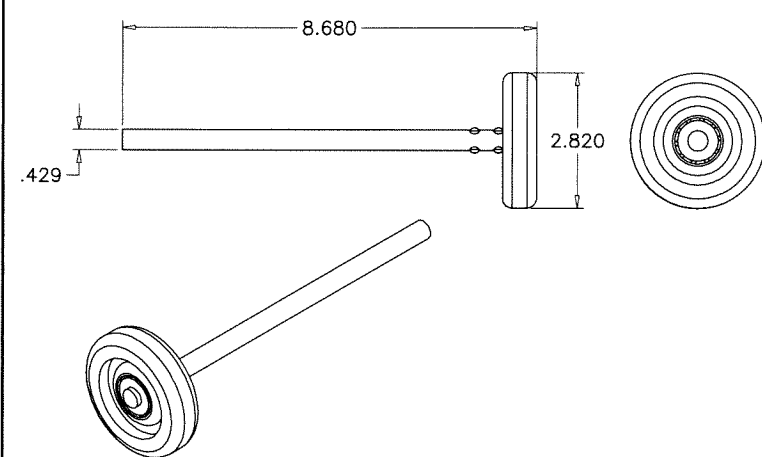

HURRICANE ROLLER-DF

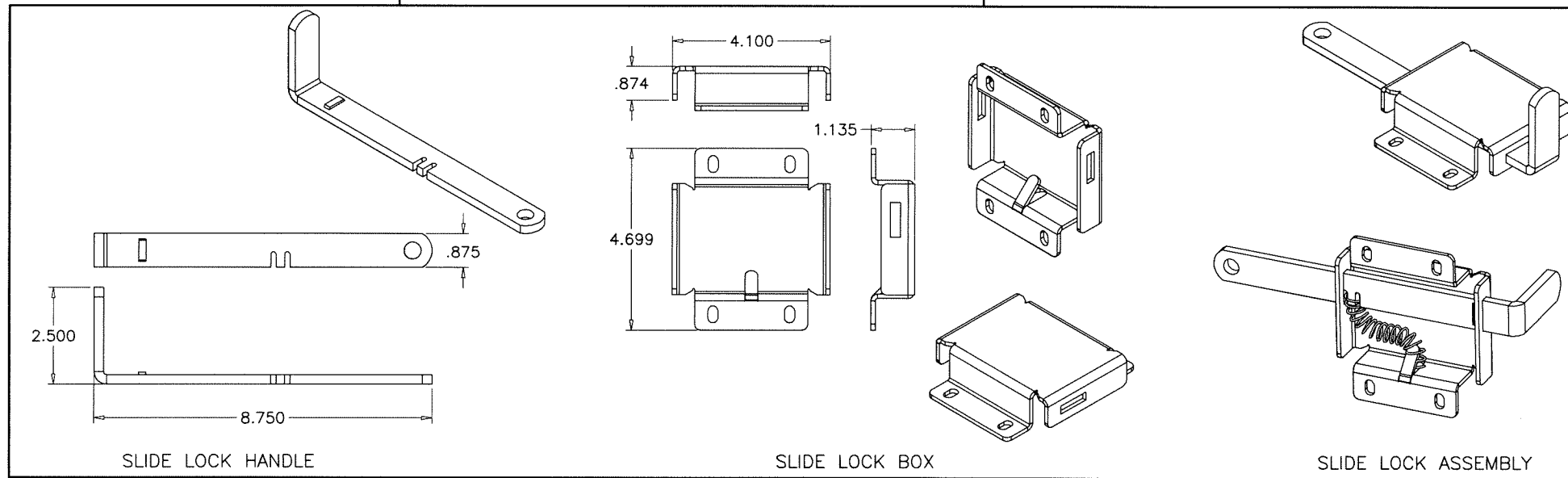

SLIDE LOCK HANDLE

SLIDE LOCK BOX

SLIDE LOCK ASSEMBLY

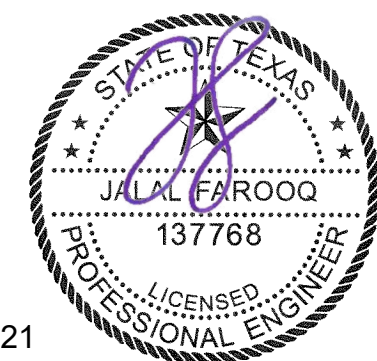

5/18/2021

afc
AL-FAROOQ CORPORATION
ENGINEERS & PRODUCT DEVELOPMENT
9360 SUNSET DRIVE, SUITE 220 (C.A.N. 3538)
MIAMI, FLORIDA 33173
TEL. (305) 264-8100 FAX. (305) 262-6978
GARAGE\21-19T-DSC

DuraFlex 18'-2" Sectional Garage Door (N.I.)
DuraServ Corp.
11431 Ferrell Drive, Suite 200
Farmers Branch, TX 75234
Tel: (800) 994-2361 Fax: (-)

no.	date	description

revisions:
date: 03-11-21
scale: 1/4" = 1"
dr. by: TARIQ
chk. by:

drawing no.
21-19T
sheet 6 of 6